

Discrete Mathematics for Computer Science

Lecture 2

Previous construction: “Laws of Logic”

Cf. Exercise 2.2.6a

Use the “Laws of Logic” to prove that:

$$\neg(p \wedge (q \vee r) \wedge (\neg p \vee \neg q \vee r)) \Leftrightarrow \neg p \vee \neg r$$

$$\neg(p \wedge (q \vee r) \wedge (\neg p \vee \neg q \vee r)) \Leftrightarrow \neg p \vee \neg r$$

Deduction

$$\neg(p \wedge (q \vee r) \wedge (\neg p \vee \neg q \vee r))$$

$$\Leftrightarrow \neg((p \wedge (q \vee r)) \wedge (\neg p \vee \neg q \vee r))$$

In case two or more consecutive \wedge or \vee operators occur without brackets, they are applied from left to right.

$$\Leftrightarrow \neg(((q \vee r) \wedge p) \wedge (\neg p \vee \neg q \vee r)) \quad \mathbf{L3}$$

$$\Leftrightarrow \neg((q \vee r) \wedge (p \wedge (\neg p \vee \neg q \vee r))) \quad \mathbf{L4}$$

$$\Leftrightarrow \neg((q \vee r) \wedge (p \wedge (\neg p \vee (\neg q \vee r)))) \quad \mathbf{L4}$$

$$\Leftrightarrow \neg((q \vee r) \wedge ((p \wedge \neg p) \vee (p \wedge (\neg q \vee r)))) \quad \mathbf{L5}$$

$$\neg(p \wedge (q \vee r) \wedge (\neg p \vee \neg q \vee r)) \Leftrightarrow \neg p \vee \neg r$$

Deduction (continued)

$$\neg(((q \vee r) \wedge ((p \wedge \neg p) \vee (p \wedge (\neg q \vee r)))))$$

$$\Leftrightarrow \neg(((q \vee r) \wedge (F_0 \vee (p \wedge (\neg q \vee r))))) \quad \mathbf{L8}$$

$$\Leftrightarrow \neg(((q \vee r) \wedge ((p \wedge (\neg q \vee r)) \vee F_0))) \quad \mathbf{L3}$$

$$\Leftrightarrow \neg(((q \vee r) \wedge (p \wedge (\neg q \vee r)))) \quad \mathbf{L7}$$

$$\Leftrightarrow \neg(((q \vee r) \wedge ((\neg q \vee r) \wedge p))) \quad \mathbf{L3}$$

$$\Leftrightarrow \neg(((q \vee r) \wedge (\neg q \vee r)) \wedge p) \quad \mathbf{L4}$$

$$\neg(p \wedge (q \vee r) \wedge (\neg p \vee \neg q \vee r)) \Leftrightarrow \neg p \vee \neg r$$

Deduction (continued)

$$\neg(((q \vee r) \wedge (\neg q \vee r)) \wedge p)$$

$$\Leftrightarrow \neg(((r \vee q) \wedge (\neg q \vee r)) \wedge p) \quad \text{L3}$$

$$\Leftrightarrow \neg(((r \vee q) \wedge (r \vee \neg q)) \wedge p) \quad \text{L3}$$

$$\Leftrightarrow \neg((r \vee (q \wedge \neg q)) \wedge p) \quad \text{L5}$$

$$\Leftrightarrow \neg((r \vee F_0) \wedge p) \quad \text{L8} \quad \Leftrightarrow \neg(r \wedge p) \quad \text{L7}$$

$$\Leftrightarrow \neg(p \wedge r) \quad \text{L3} \quad \Leftrightarrow \neg p \vee \neg r \quad \text{L2}$$

Conclusion: $\neg(p \wedge (q \vee r) \wedge (\neg p \vee \neg q \vee r)) \Leftrightarrow \neg p \vee \neg r$

§2.3: Logical implications

The statements $\alpha_1, \dots, \alpha_n$ are said to logically imply statement β if

$$(\alpha_1 \wedge \alpha_2 \wedge \dots \wedge \alpha_n) \rightarrow \beta$$

is a tautology.

$\alpha_1, \dots, \alpha_n$ are the premises and β is the conclusion

Logical implication / valid argument

If $(\alpha_1 \wedge \alpha_2 \wedge \dots \wedge \alpha_n) \rightarrow \beta$

is a tautology, then this is denoted by:

$$(\alpha_1 \wedge \alpha_2 \wedge \dots \wedge \alpha_n) \Rightarrow \beta$$

and is called a logical implication.

Other formulations:

- $(\alpha_1 \wedge \dots \wedge \alpha_n) \rightarrow \beta$ is a valid argument
- β is deducible from $\alpha_1, \dots, \alpha_n$

Logical implication / valid argument

Note: The truth tables for “ \wedge ” and “ \rightarrow ” imply that if we want to verify whether

$$\left(\alpha_1 \wedge \alpha_2 \wedge \cdots \wedge \alpha_n \right) \rightarrow \beta$$

is a valid argument ,

we only need to verify that, in case all premises $\alpha_1, \dots, \alpha_n$ are true, also the conclusion β is true!

Example

Use a truth table to prove that:

$$\left((p \rightarrow q) \wedge \neg q \right) \Rightarrow \neg p$$

$$((p \rightarrow q) \wedge \neg q) \Rightarrow \neg p$$

Solution

p	q	$p \rightarrow q$	$\neg q$	$(p \rightarrow q) \wedge \neg q$	$\neg p$	$((p \rightarrow q) \wedge \neg q) \rightarrow \neg p$
0	0	1	1	1	1	1
0	1	1	0	0	1	1
1	0	0	1	0	0	1
1	1	1	0	0	0	1

Tautology

Logical implication / valid argument

A valid argument

$$(\alpha_1 \wedge \alpha_2 \wedge \cdots \wedge \alpha_n) \Rightarrow \beta$$

is often written in tabular form:

$$\begin{array}{c} \alpha_1 \\ \alpha_2 \\ \vdots \\ \alpha_n \\ \hline \therefore \beta \end{array}$$

The symbol “ \therefore ”
is pronounced as:
“therefore”

Rules of Inference

All “Rules of Inference” on the formula sheet (R1,..., R12) are valid arguments (this can easily be proved using truth tables).

Together with the “Laws of Logic” they can be used to construct more complicated deductions.

Example

Use a truth table to prove that Inference Rule R2:

$$\frac{p \rightarrow q \quad q \rightarrow r}{\therefore p \rightarrow r}$$

is a valid argument.

Solution

$$\begin{array}{l} p \rightarrow q \\ q \rightarrow r \\ \hline \therefore p \rightarrow r \end{array}$$

We must show that:

$$((p \rightarrow q) \wedge (q \rightarrow r)) \rightarrow (p \rightarrow r)$$

is a tautology.

Solution (continued)

$$\begin{array}{l} p \rightarrow q \\ q \rightarrow r \\ \hline \therefore p \rightarrow r \end{array}$$

p	q	r	$p \rightarrow q$	$q \rightarrow r$	$(p \rightarrow q) \wedge (q \rightarrow r)$	$p \rightarrow r$	$((p \rightarrow q) \wedge (q \rightarrow r)) \rightarrow (p \rightarrow r)$
0	0	0	1	1	1	1	1
0	0	1	1	1	1	1	1
0	1	0	1	0	0	1	1
0	1	1	1	1	1	1	1
1	0	0	0	1	0	0	1
1	0	1	0	1	0	1	1
1	1	0	1	0	0	0	1
1	1	1	1	1	1	1	1

Tautology

Example 1

Use the “Laws of Logic” and “Rules of Inference” to show that the following argument is valid.

$$\begin{array}{l} p \rightarrow r \\ \neg p \rightarrow q \\ q \rightarrow s \\ \hline \therefore \neg r \rightarrow s \end{array}$$

Deduction

$$p \rightarrow r$$

$$\neg p \rightarrow q$$

$$q \rightarrow s$$

$$\therefore \neg r \rightarrow s$$

Step

Argument

(1) $p \rightarrow r$

Premise

(2) $\neg r \rightarrow \neg p$

(1), L13

(3) $\neg p \rightarrow q$

Premise

(4) $\neg r \rightarrow q$

(2), (3), R2

(5) $q \rightarrow s$

Premise

(6) $\therefore \neg r \rightarrow s$

(4), (5), R2

Alternative deduction

$$p \rightarrow r$$

$$\neg p \rightarrow q$$

$$q \rightarrow s$$

$$\therefore \neg r \rightarrow s$$

Step

Argument

(1) $\neg p \rightarrow q$

Premise

(2) $\neg\neg p \vee q$

(1), L12

(3) $p \vee q$

(2), L1

(4) $p \rightarrow r$

Premise

(5) $q \rightarrow s$

Premise

(6) $r \vee s$

(4), (5), (3), R11

(7) $\neg\neg r \vee s$

(6), L1

(8) $\therefore \neg r \rightarrow s$

(7), L12

Example 2

Use the “Laws of Logic” and “Rules of Inference” to show that the following argument is valid.

$$\begin{array}{c} p \wedge q \\ p \rightarrow (r \wedge q) \\ r \rightarrow (s \vee t) \\ \neg t \\ \hline \therefore s \end{array}$$

Deduction

$$\begin{array}{l} p \wedge q \\ p \rightarrow (q \wedge r) \\ r \rightarrow (s \vee t) \\ \hline \neg t \\ \hline \therefore s \end{array}$$

Step

Argument

(1)	$p \wedge q$	Premise
(2)	p	(1), R7
(3)	$p \rightarrow (q \wedge r)$	Premise
(4)	$q \wedge r$	(2), (3), R1
(5)	$r \wedge q$	(4), L3
(6)	r	(5), R7
(7)	$r \rightarrow (s \vee t)$	Premise

Step

Argument

(8)	$s \vee t$	(6), (7), R1
(9)	$t \vee s$	(8), L3
(10)	$\neg t$	Premise
(11)	$\therefore s$	(9), (10), R5

Rule of Contradiction

The following truth table shows that the implications $p \rightarrow q$ and $(p \wedge \neg q) \rightarrow F_0$ are logically equivalent.

p	q	$p \rightarrow q$	$\neg q$	$p \wedge \neg q$	F_0	$(p \wedge \neg q) \rightarrow F_0$
0	0	1	1	0	0	1
0	1	1	0	0	0	1
1	0	0	1	1	0	0
1	1	1	0	0	0	1

So: $p \rightarrow q \Leftrightarrow (p \wedge \neg q) \rightarrow F_0$

Rule of Contradiction

$$p \rightarrow q \Leftrightarrow (p \wedge \neg q) \rightarrow F_0$$

If we apply substitution rule 1 and replace in this tautology each occurrence of the primitive statement p with $\alpha_1, \dots, \alpha_n$, we obtain that the implication

$$(\alpha_1 \wedge \alpha_2 \wedge \dots \wedge \alpha_n) \rightarrow q$$

is logically equivalent to the implication

$$((\alpha_1 \wedge \alpha_2 \wedge \dots \wedge \alpha_n) \wedge \neg q) \rightarrow F_0$$

Rule of Contradiction

$$\left((\alpha_1 \wedge \alpha_2 \wedge \cdots \wedge \alpha_n) \wedge \neg q \right) \rightarrow F_0$$

is logically equivalent to:

$$(\alpha_1 \wedge \alpha_2 \wedge \cdots \wedge \alpha_n) \rightarrow q$$

In other words: if one can deduce a contradiction (F_0) from the premises $\alpha_1, \dots, \alpha_n$, together with the extra premise $\neg q$, then q is deducible from the premises $\alpha_1, \dots, \alpha_n$.

Example

The following arguments are equivalent:

$$\begin{array}{c} p \vee q \\ \neg p \vee r \\ \neg r \\ \hline \therefore q \end{array}$$

and

$$\begin{array}{c} p \vee q \\ \neg p \vee r \\ \neg r \\ \neg q \\ \hline \therefore F_0 \end{array}$$

In the 2nd derivation:

$p \vee q$ $\neg p \vee r$ and $\neg r$ are the premises, and $\neg q$ is the extra premise.

Deduction Theorem

The following truth table shows that the implications $(p \wedge q) \rightarrow r$ and $p \rightarrow (q \rightarrow r)$ are logically equivalent.

p	q	r	$p \wedge q$	$(p \wedge q) \rightarrow r$	$q \rightarrow r$	$p \rightarrow (q \rightarrow r)$
0	0	0	0	1	1	1
0	0	1	0	1	1	1
0	1	0	0	1	0	1
0	1	1	0	1	1	1
1	0	0	0	1	1	1
1	0	1	0	1	1	1
1	1	0	1	0	0	0
1	1	1	1	1	1	1

Deduction Theorem

So: $(p \wedge q) \rightarrow r \Leftrightarrow p \rightarrow (q \rightarrow r)$

If we apply substitution rule 1 and replace in this tautology each occurrence of the primitive statement p with $\alpha_1, \dots, \alpha_n$, we obtain that the implication

$$((\alpha_1 \wedge \alpha_2 \wedge \dots \wedge \alpha_n) \wedge q) \rightarrow r$$

is logically equivalent to the implication

$$((\alpha_1 \wedge \alpha_2 \wedge \dots \wedge \alpha_n)) \rightarrow (q \rightarrow r)$$

Alternative deduction

$$\left((\alpha_1 \wedge \alpha_2 \wedge \cdots \wedge \alpha_n) \wedge q \right) \rightarrow r$$

is logically equivalent to:

$$\left(\alpha_1 \wedge \alpha_2 \wedge \cdots \wedge \alpha_n \right) \rightarrow (q \rightarrow r)$$

So: if one can deduce r from the premises $\alpha_1, \dots, \alpha_n$, together with the extra premise q , then $q \rightarrow r$ is deducible from the premises $\alpha_1, \dots, \alpha_n$.

Example

The following arguments are equivalent:

$$\begin{array}{l} p \rightarrow r \\ \neg p \rightarrow q \\ q \rightarrow s \\ \hline \therefore \neg r \rightarrow s \end{array}$$

and

$$\begin{array}{l} p \rightarrow r \\ \neg p \rightarrow q \\ q \rightarrow s \\ \neg r \\ \hline \therefore s \end{array}$$

In the 2nd derivation:

$p \rightarrow r$ $\neg p \rightarrow q$ $q \rightarrow s$ are the premises, and
 $\neg r$ is the extra premise.

Valid and invalid argument (1)

In order to prove that an argument is valid, we must consider all possible cases in which the premisses are true.

This can be done by:

- a. A truth table or
- b. A deduction using the “Laws of Logic” and “Rules of Inference”

Valid and invalid argument (2)

To prove that an argument is invalid, it suffices to give just one counterexample: truth values for the primitive statements that make all premises true and the conclusion false.

Example

Show that the following argument is invalid:

$$p \leftrightarrow q$$

$$q \rightarrow r$$

$$r \vee \neg s$$

$$\frac{\neg s \rightarrow q}{\therefore s}$$

Solution

$$p \leftrightarrow q$$

$$q \rightarrow r$$

$$r \vee \neg s$$

$$\frac{\neg s \rightarrow q}{\therefore s}$$

Take: $p = 1; q = 1; r = 1$ en $s = 0$.

Then all 4 premises are true (verify!),
but the conclusion is false.

Application: Gating Networks (Chapter 15)

Note: $p \rightarrow q \Leftrightarrow \neg p \vee q$ L12

and $p \leftrightarrow q \Leftrightarrow (p \rightarrow q) \wedge (q \rightarrow p)$ L11

$\Leftrightarrow (\neg p \vee q) \wedge (\neg q \vee p)$ L12 (2x)

So each proposition with connectives \neg , \wedge , \vee , \rightarrow and \leftrightarrow , is equivalent to a proposition that only contains the connectives \neg , \wedge and \vee . In fact, each proposition can be described only using the connectives \neg , \wedge and \vee . Therefore the set $\{\neg, \wedge, \vee\}$ is called functionally complete.

Logic Gates; Gating Networks (Combinatorial Circuits)

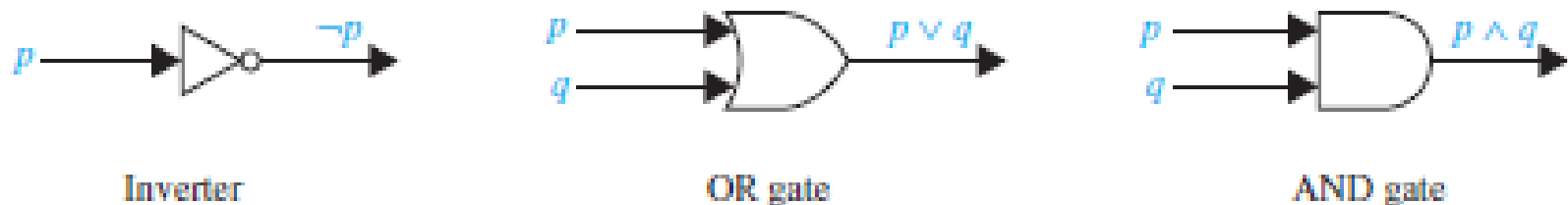

FIGURE 1 Basic logic gates.

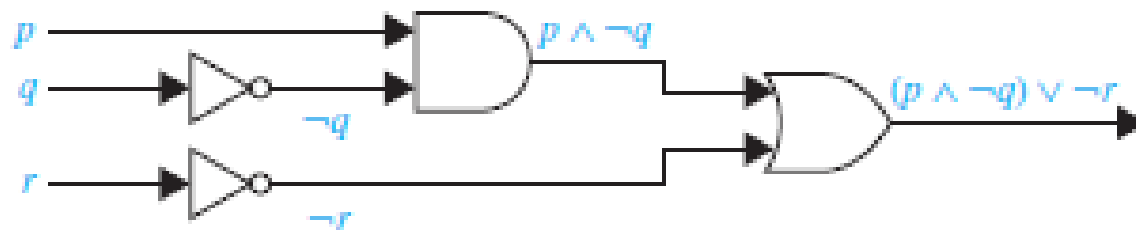

FIGURE 2 A combinational circuit.

Simplification Gating Networks

It can be shown that $(p \wedge q \wedge r) \vee (p \wedge \neg q \wedge r) \Leftrightarrow p \wedge r$

(e.g. by Laws of Logic or a truth table)

So:

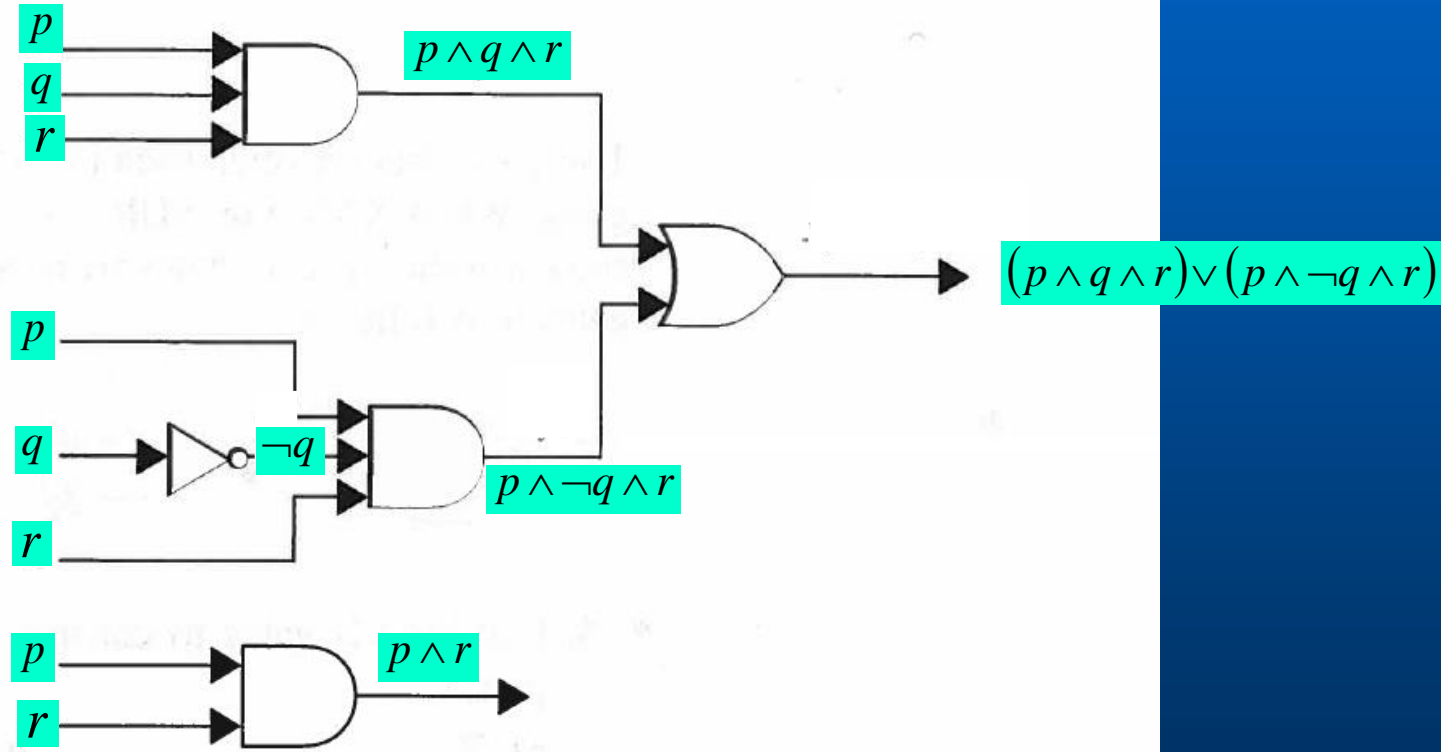

FIGURE 1 Two Circuits with the Same Output.

Logic and Boolean Algebra

Boolean Algebra (binary computation)

One unary and two binary operations:

Complementation

$$\overline{0} = 1$$

$$\overline{1} = 0$$

Addition

$$0 + 0 = 0$$

$$0 + 1 = 1$$

$$1 + 0 = 1$$

$$1 + 1 = 1$$

Multiplication

$$0 \cdot 0 = 0$$

$$0 \cdot 1 = 0$$

$$1 \cdot 0 = 0$$

$$1 \cdot 1 = 1$$

Note how the Laws of Computation in Boolean Algebra correspond to the Laws of Logic

(\overline{x} and $\neg p$ $x + y$ and $p \vee q$ $x \cdot y$ and $p \wedge q$):

see next slide:

1) $\overline{\overline{x}} = x$

2) $\overline{x + y} = \overline{x} \overline{y}$
 $\overline{xy} = \overline{x} + \overline{y}$

3) $x + y = y + x$
 $xy = yx$

4) $x + (y + z) = (x + y) + z$
 $x(yz) = (xy)z$

5) $x + yz = (x + y)(x + z)$
 $x(y + z) = xy + xz$

6) $x + x = x$
 $xx = x$

7) $x + 0 = x$
 $x \cdot 1 = x$

8) $x + \overline{x} = 1$
 $x\overline{x} = 0$

9) $x + 1 = 1$
 $x \cdot 0 = 0$

10) $x + xy = x$
 $x(x + y) = x$

1) $\neg\neg p \Leftrightarrow p$

2) $\neg(p \vee q) \Leftrightarrow \neg p \wedge \neg q$
 $\neg(p \wedge q) \Leftrightarrow \neg p \vee \neg q$

3) $p \vee q \Leftrightarrow q \vee p$
 $p \wedge q \Leftrightarrow q \wedge p$

4) $p \vee (q \vee r) \Leftrightarrow (p \vee q) \vee r$
 $p \wedge (q \wedge r) \Leftrightarrow (p \wedge q) \wedge r$

5) $p \vee (q \wedge r) \Leftrightarrow (p \vee q) \wedge (p \vee r)$
 $p \wedge (q \vee r) \Leftrightarrow (p \wedge q) \vee (p \wedge r)$

6) $p \vee p \Leftrightarrow p$
 $p \wedge p \Leftrightarrow p$

7) $p \vee F_0 \Leftrightarrow p$
 $p \wedge T_0 \Leftrightarrow p$

8) $p \vee \neg p \Leftrightarrow T_0$
 $p \wedge \neg p \Leftrightarrow F_0$

9) $p \vee T_0 \Leftrightarrow T_0$
 $p \wedge F_0 \Leftrightarrow F_0$

10) $p \vee (p \wedge q) \Leftrightarrow p$
 $p \wedge (p \vee q) \Leftrightarrow p$

\overline{x} and $\neg p$

$x + y$ and $p \vee q$

$x \cdot y$ and $p \wedge q$

Logic Gates in Boolean Algebra

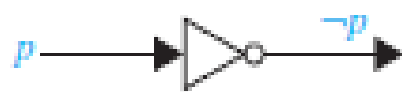

Inverter



OR gate

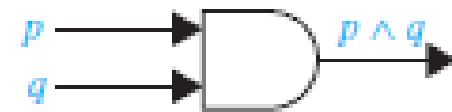

AND gate

FIGURE 1 Basic logic gates.



(a) Inverter



(b) OR gate

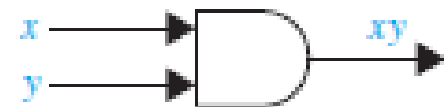

(c) AND gate

FIGURE 1 Basic Types of Gates.

Gating Networks : Majority Voting

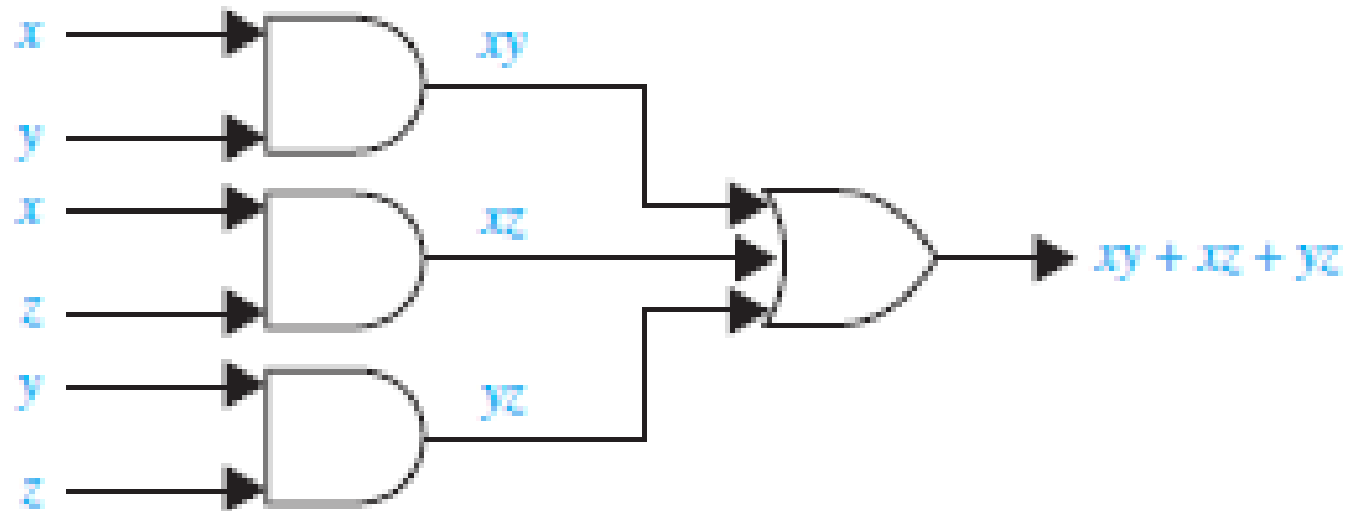
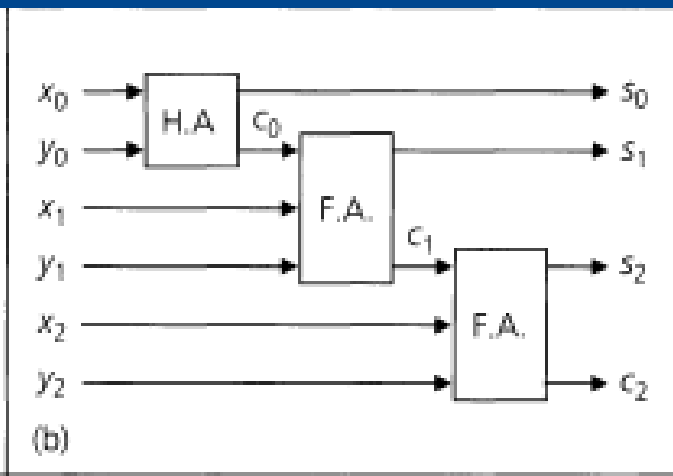
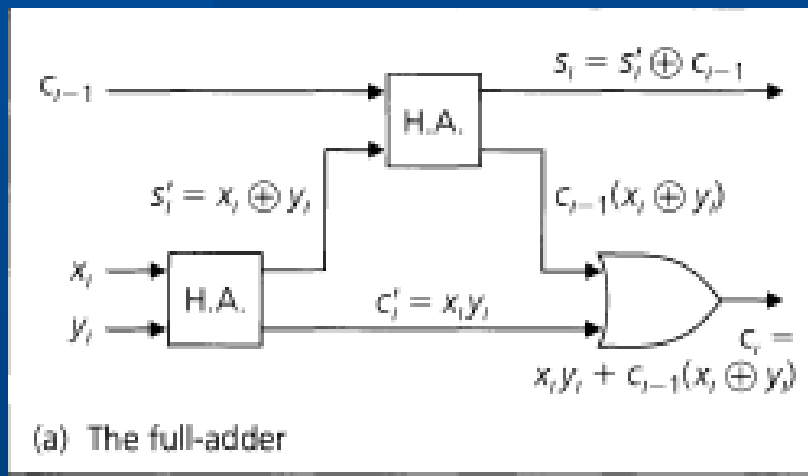
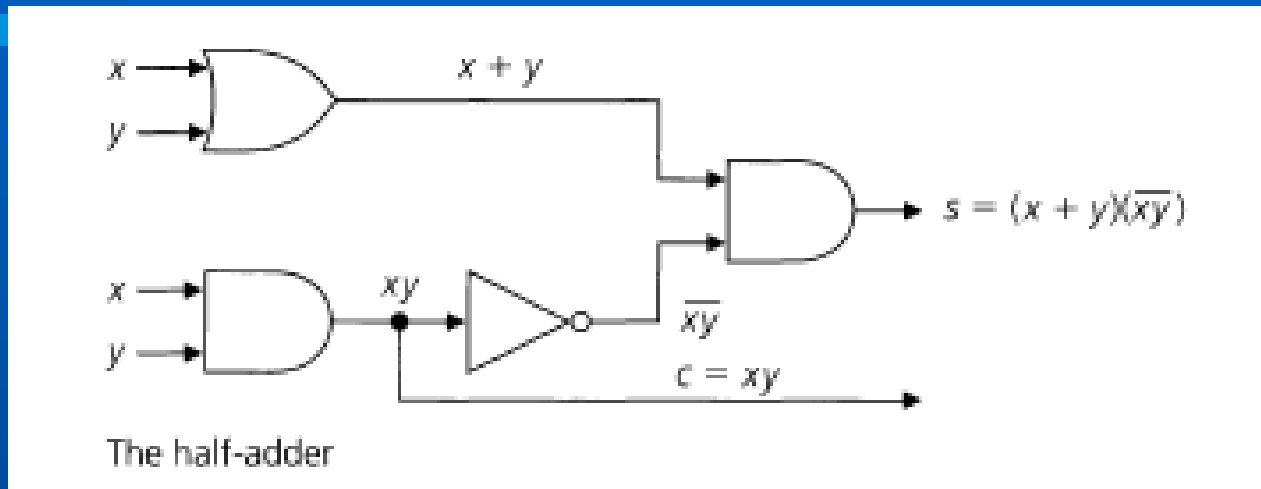

FIGURE 5 A Circuit for Majority Voting.

Gating Networks : Calculators

Addition of binary numbers:



Minimization of Gating Networks : Karnaugh Maps

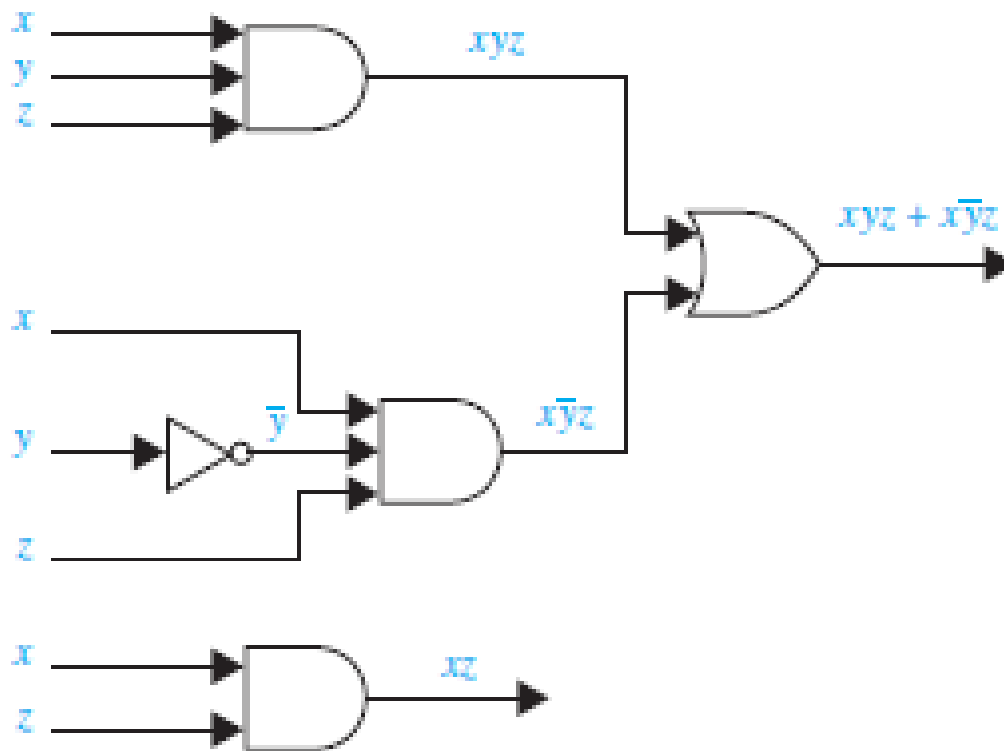

FIGURE 1 Two Circuits with the Same Output.