

# INSTRUCTOR'S SOLUTIONS MANUAL

## DISCRETE AND COMBINATORIAL MATHEMATICS

FIFTH EDITION

Ralph P. Grimaldi

*Rose-Hulman Institute of Technology*



Boston San Francisco New York  
London Toronto Sydney Tokyo Singapore Madrid  
Mexico City Munich Paris Cape Town Hong Kong Montreal

Reproduced by Pearson Addison-Wesley from electronic files supplied by the author.

Copyright © 2004 Pearson Education, Inc.

Publishing as Pearson Addison-Wesley, 75 Arlington Street, Boston, MA 02116

All rights reserved. No part of this publication may be reproduced, stored in a retrieval system, or transmitted, in any form or by any means, electronic, mechanical, photocopying, recording, or otherwise, without the prior written permission of the publisher. Printed in the United States of America.

ISBN 0-201-72660-2

1 2 3 4 5 6 CRS 06 05 04 03



*Dedicated to  
the memory of  
Nellie and Glen (Fuzzy) Shidler*

# TABLE OF CONTENTS

## PART 1

### FUNDAMENTALS OF DISCRETE MATHEMATICS 1

Chapter 1	Fundamental Principles of Counting	3
Chapter 2	Fundamentals of Logic	26
Chapter 3	Set Theory	59
Chapter 4	Properties of the Integers: Mathematical Induction	95
Chapter 5	Relations and Functions	134
Chapter 6	Languages: Finite State Machines	167
Chapter 7	Relations: The Second Time Around	179

## PART 2

### FURTHER TOPICS IN ENUMERATION 207

Chapter 8	The Principle of Inclusion and Exclusion	209
Chapter 9	Generating Functions	229
Chapter 10	Recurrence Relations	243

## PART 3

### GRAPH THEORY AND APPLICATIONS 285

Chapter 11	An Introduction to Graph Theory	287
Chapter 12	Trees	328
Chapter 13	Optimization and Matching	354

**PART 4****MODERN APPLIED ALGEBRA** 367

Chapter 14 Rings and Modular Arithmetic 369

Chapter 15 Boolean Algebra and Switching Functions 396

Chapter 16 Groups, Coding Theory, and Polya's Method of Enumeration 413

Chapter 17 Finite Fields and Combinatorial Designs 440

**THE APPENDICES** 459

Appendix 1 Exponential and Logarithmic Functions 461

Appendix 2 Properties of Matrices 464

Appendix 3 Countable and Uncountable Sets 468

**PART 1**

**FUNDAMENTALS**

**OF**

**DISCRETE MATHEMATICS**

**CHAPTER 1**  
**FUNDAMENTAL PRINCIPLES OF COUNTING**

**Sections 1.1 and 1.2**

1. (a) By the rule of sum, there are  $8 + 5 = 13$  possibilities for the eventual winner.  
(b) Since there are eight Republicans and five Democrats, by the rule of product we have  $8 \times 5 = 40$  possible pairs of opposing candidates.  
(c) The rule of sum in part (a); the rule of product in part (b).
2. By the rule of product there are  $5 \times 5 \times 5 \times 5 \times 5 \times 5 = 5^6$  license plates where the first two symbols are vowels and the last four are even digits.
3. By the rule of product there are (a)  $4 \times 12 \times 3 \times 2 = 288$  distinct Buicks that can be manufactured. Of these, (b)  $4 \times 1 \times 3 \times 2 = 24$  are blue.
4. (a) From the rule of product there are  $10 \times 9 \times 8 \times 7 = P(10, 4) = 5040$  possible slates.  
(b) (i) There are  $3 \times 9 \times 8 \times 7 = 1512$  slates where a physician is nominated for president.  
(ii) The number of slates with exactly one physician appearing is  $4 \times [3 \times 7 \times 6 \times 5] = 2520$ .  
(iii) There are  $7 \times 6 \times 5 \times 4 = 840$  slates where no physician is nominated for any of the four offices. Consequently,  $5040 - 840 = 4200$  slates include at least one physician.
5. Based on the evidence supplied by Jennifer and Tiffany, from the rule of product we find that there are  $2 \times 2 \times 1 \times 10 \times 10 \times 2 = 800$  different license plates.
6. (a) Here we are dealing with the permutations of 30 objects (the runners) taken 8 (the first eight finishing positions) at a time.. So the trophies can be awarded in  $P(30, 8) = 30!/22!$  ways.  
(b) Roberta and Candice can finish among the top three runners in 6 ways. For each of these 6 ways, there are  $P(28, 6)$  ways for the other 6 finishers (in the top 8) to finish the race. By the rule of product there are  $6 \cdot P(28, 6)$  ways to award the trophies with these two runners among the top three.
7. By the rule of product there are  $2^9$  possibilities.
8. By the rule of product there are (a)  $12!$  ways to process the programs if there are no restrictions; (b)  $(4!)(8!)$  ways so that the four higher priority programs are processed first; and (c)  $(4!)(5!)(3!)$  ways where the four top priority programs are processed first and the three programs of least priority are processed last.

9. (a)  $(14)(12) = 168$   
 (b)  $(14)(12)(6)(18) = 18,144$   
 (c)  $(8)(18)(6)(3)(14)(12)(14)(12) = 73,156,608$
10. Consider one such arrangement – say we have three books on one shelf and 12 on the other. This can be accomplished in  $15!$  ways. In fact for any subdivision (resulting in two nonempty shelves) of the 15 books we get  $15!$  ways to arrange the books on the two shelves. Since there are 14 ways to subdivide the books so that each shelf has at least one book, the total number of ways in which Pamela can arrange her books in this manner is  $(14)(15!)$ .
11. (a) There are four roads from town A to town B and three roads from town B to town C, so by the rule of product there are  $4 \times 3 = 12$  roads from A to C that pass through B. Since there are two roads from A to C directly, there are  $12 + 2 = 14$  ways in which Linda can make the trip from A to C.  
 (b) Using the result from part (a), together with the rule of product, we find that there are  $14 \times 14 = 196$  different round trips (from A to C and back to A).  
 (c) Here there are  $14 \times 13 = 182$  round trips.
12. (1) a,c,t      (2) a,t,c      (3) c,a,t      (4) c,t,a      (5) t,a,c      (6) t,c,a
13. (a)  $8! = P(8, 8)$       (b)  $7!$        $6!$
14. (a)  $P(7, 2) = 7!/(7-2)! = 7!/5! = (7)(6) = 42$   
 (b)  $P(8, 4) = 8!/(8-4)! = 8!/4! = (8)(7)(6)(5) = 1680$   
 (c)  $P(10, 7) = 10!/(10-7)! = 10!/3! = (10)(9)(8)(7)(6)(5)(4) = 604,800$   
 (d)  $P(12, 3) = 12!/(12-3)! = 12!/9! = (12)(11)(10) = 1320$
15. Here we must place a,b,c,d in the positions denoted by x: e x e x e x e x e. By the rule of product there are  $4!$  ways to do this.
16. (a) With repetitions allowed there are  $40^{25}$  distinct messages.  
 (b) By the rule of product there are  $40 \times 30 \times 30 \times \dots \times 30 \times 30 \times 40 = (40^2)(30^{23})$  messages.
17. Class A:  $(2^7 - 2)(2^{24} - 2) = 2,113,928,964$   
 Class B:  $2^{14}(2^{16} - 2) = 1,073,709,056$   
 Class C:  $2^{21}(2^8 - 2) = 532,676,608$
18. From the rule of product we find that there are  $(7)(4)(3)(6) = 504$  ways for Morgan to configure her low-end computer system.
19. (a)  $7! = 5040$       (b)  $4 \times 3 \times 3 \times 2 \times 2 \times 1 \times 1 = (4!)(3!) = 144$   
 (c)  $(3!)(5)(4!) = 720$       (d)  $(3!)(4!)(2) = 288$
20. (a) Since there are three A's, there are  $8!/3! = 6720$  arrangements.

(b) Here we arrange the six symbols D,T,G,R,M, AAA in  $6! = 720$  ways.

21. (a)  $12!/(3!2!2!)$   
(b)  $[11!/(3!2!2!)]$  (for AG) +  $[11!/(3!2!2!)]$  (for GA)  
(c) Consider one case where all the vowels are adjacent: S,C,L,G,C,L, OIOOIA. These seven symbols can be arranged in  $(7!)/(2!2!)$  ways. Since O,O,O,I,I,A can be arranged in  $(6!)/(3!2!)$  ways, the number of arrangements with all the vowels adjacent is  $[7!/(2!2!)] [6!/(3!2!)]$ .
22. (Case 1: The leading digit is 5)  $(6!)/(2!)$   
(Case 2: The leading digit is 6)  $(6!)/(2!)^2$   
(Case 3: The leading digit is 7)  $(6!)/(2!)^2$   
In total there are  $[(6!)/(2!)] [1 + (1/2) + (1/2)] = 6! = 720$  such positive integers  $n$ .
23. Here the solution is the number of ways we can arrange 12 objects — 4 of the first type, 3 of the second, 2 of the third, and 3 of the fourth. There are  $12!/(4!3!2!3!) = 277,200$  ways.
24.  $P(n+1, r) = (n+1)!/(n+1-r)! = [(n+1)/(n+1-r)] \cdot [n!/(n-r)!] = [(n+1)/(n+1-r)] P(n, r)$ .
25. (a)  $n = 10$  (b)  $n = 5$   
(c)  $2n!/(n-2)! + 50 = (2n)!/(2n-2)! \implies 2n(n-1) + 50 = (2n)(2n-1) \implies n^2 = 25 \implies n = 5$ .
26. Any such path from (0,0) to (7,7) or from (2,7) to (9,14) is an arrangement of 7 R's and 7 U's. There are  $(14!)/(7!7!)$  such arrangements.  
In general, for  $m, n$  nonnegative integers, and any real numbers  $a, b$ , the number of such paths from  $(a, b)$  to  $(a+m, b+n)$  is  $(m+n)!/(m!n!)$ .
27. (a) Each path consists of 2 H's, 1 V, and 7 A's. There are  $10!/(2!1!7!)$  ways to arrange these 10 letters and this is the number of paths.  
(b)  $10!/(2!1!7!)$   
(c) If  $a, b$ , and  $c$  are any real numbers and  $m, n$ , and  $p$  are nonnegative integers, then the number of paths from  $(a, b, c)$  to  $(a+m, b+n, c+p)$  is  $(m+n+p)!/(m!n!p!)$ .
28. (a) The for loop for  $i$  is executed 12 times, while those for  $j$  and  $k$  are executed  $10-5+1 = 6$  and  $15-8+1 = 8$  times, respectively. Consequently, following the execution of the given program segment, the value of *counter* is

$$0 + 12(1) + 6(2) + 8(3) = 48.$$

(b) Here we have three tasks —  $T_1$ ,  $T_2$ , and  $T_3$ . Task  $T_1$  takes place each time we traverse the instructions in the  $i$  loop. Similarly, tasks  $T_2$  and  $T_3$  take place during each iteration of the  $j$  and  $k$  loops, respectively. The final value for the integer variable *counter* follows by the rule of sum.

29. (a) & (b) By the rule of product the print statement is executed  $12 \times 6 \times 8 = 576$  times.
30. (a) For five letters there are  $26 \times 26 \times 26 \times 1 \times 1 = 26^3$  palindromes. There are  $26 \times 26 \times 26 \times 1 \times 1 \times 1 = 26^3$  palindromes for six letters.  
 (b) When letters may not appear more than two times, there are  $26 \times 25 \times 24 = 15,600$  palindromes for either five or six letters.
31. By the rule of product there are (a)  $9 \times 9 \times 8 \times 7 \times 6 \times 5 = 136,080$  six-digit integers with no leading zeros and no repeated digit. (b) When digits may be repeated there are  $9 \times 10^5$  such six-digit integers.  
 (i) (a)  $(9 \times 8 \times 7 \times 6 \times 5 \times 1)$  (for the integers ending in 0) +  $(8 \times 8 \times 7 \times 6 \times 5 \times 4)$  (for the integers ending in 2,4,6, or 8) = 68,800. (b) When the digits may be repeated there are  $9 \times 10 \times 10 \times 10 \times 10 \times 5 = 450,000$  six-digit even integers.  
 (ii) (a)  $(9 \times 8 \times 7 \times 6 \times 5 \times 1)$  (for the integers ending in 0) +  $(8 \times 8 \times 7 \times 6 \times 5 \times 1)$  (for the integers ending in 5) = 28,560. (b)  $9 \times 10 \times 10 \times 10 \times 10 \times 2 = 180,000$ .  
 (iii) We use the fact that an integer is divisible by 4 if and only if the integer formed by the last two digits is divisible by 4. (a)  $(8 \times 7 \times 6 \times 5 \times 6)$  (last two digits are 04, 08, 20, 40, 60, or 80) +  $(7 \times 7 \times 6 \times 5 \times 16)$  (last two digits are 12, 16, 24, 28, 32, 36, 48, 52, 56, 64, 68, 72, 76, 84, 92, or 96) = 33,600. (b)  $9 \times 10 \times 10 \times 10 \times 25 = 225,000$ .
32. (a) For positive integers  $n, k$ , where  $n = 3k$ ,  $n!/(3!)^k$  is the number of ways to arrange the  $n$  objects  $x_1, x_1, x_1, x_2, x_2, x_2, \dots, x_k, x_k, x_k$ . This must be an integer.  
 (b) If  $n, k$  are positive integers with  $n = mk$ , then  $n!/(m!)^k$  is an integer.
33. (a) With 2 choices per question there are  $2^{10} = 1024$  ways to answer the examination.  
 (b) Now there are 3 choices per question and  $3^{10}$  ways.
34.  $(4!/2!)$  (No 7's) +  $(4!)$  (One 7 and one 3) +  $(2)(4!/2!)$  (One 7 and two 3's) +  $(4!/2!)$  (Two 7's and no 3's) +  $(2)(4!/2!)$  (Two 7's and one 3) +  $(4!/(2!2!))$  (Two 7's and two 3's). The total gives us 102 such four-digit integers.
35. (a)  $6!$  (b) Let A,B denote the two people who insist on sitting next to each other. Then there are  $5!$  (A to the right of B) +  $5!$  (B to the right of A) =  $2(5!)$  seating arrangements.
36. (a) Locate A. There are two cases to consider. (1) There is a person to the left of A on the same side of the table. There are  $7!$  such seating arrangements. (2) There is a person to the right of A on the same side of the table. This gives  $7!$  more arrangements. So there are  $2(7!)$  possibilities. (b) 7200
37. We can select the 10 people to be seated at the table for 10 in  $\binom{16}{10}$  ways. For each such selection there are  $9!$  ways of arranging the 10 people around the table. The remaining six people can be seated around the other table in  $5!$  ways. Consequently, there are  $\binom{16}{10}9!5!$  ways to seat the 16 people around the two given tables.

38. The nine women can be situated around the table in  $8!$  ways. Each such arrangement provides nine spaces (between women) where a man can be placed. We can select six of these places and situate a man in each of them in  $\binom{9}{6}6! = 9 \cdot 8 \cdot 7 \cdot 6 \cdot 5 \cdot 4$  ways. Consequently, the number of seating arrangements under the given conditions is  $(8!)\binom{9}{6}6! = 2,438,553,600$ .

39.

```
procedure SumOfFact(i, sum: positive integers; j,k: nonnegative integers;
                   factorial: array [0..9] of ten positive integers)
```

```
begin
```

```
  factorial [0] := 1
```

```
  for i := 1 to 9 do
```

```
    factorial [i] := i * factorial [i - 1]
```

```
  for i := 1 to 9 do
```

```
    for j := 0 to 9 do
```

```
      for k := 0 to 9 do
```

```
        begin
```

```
          sum := factorial [i] + factorial [j] + factorial [k]
```

```
          if (100 * i + 10 * j + k) = sum then
```

```
            print (100 * i + 10 * j + k)
```

```
        end
```

```
end
```

The unique answer is 145 since  $(1!) + (4!) + (5!) = 1 + 24 + 120 = 145$ .

### Section 1.3

1.  $\binom{6}{2} = 6!/[2!(6-2)!] = 6!/(2!4!) = (6)(5)/2 = 15$

a	b	b	c	c	e
a	c	b	d	c	f
a	d	b	e	d	e
a	e	b	f	d	f
a	f	c	d	e	f

2. Order is not relevant here and Diane can make her selection in  $\binom{12}{5} = 792$  ways.

3. (a)  $C(10, 4) = 10!/(4!6!) = (10)(9)(8)(7)/(4)(3)(2)(1) = 210$

(b)  $\binom{12}{7} = 12!/(7!5!) = (12)(11)(10)(9)(8)/(5)(4)(3)(2)(1) = 792$

(c)  $C(14, 12) = 14!/(12!2!) = (14)(13)/(2)(1) = 91$

(d)  $\binom{15}{10} = 15!/(10!5!) = (15)(14)(13)(12)(11)/(5)(4)(3)(2)(1) = 3003$

4. (a)  $2^6 - 1 = 63$

(b)  $\binom{6}{3} = 20$

(c)  $\binom{6}{2} + \binom{6}{4} + \binom{6}{6} = 31$

5. (a) There are  $P(5, 3) = 5!/(5-3)! = 5!/2! = (5)(4)(3) = 60$  permutations of size 3 for the five letters m, r, a, f, and t.

(b) There are  $C(5, 3) = 5!/[3!(5-3)!] = 5!/(3!2!) = 10$  combinations of size 3 for the five letters m, r, a, f, and t. They are

a,f,m  
a,r,t

a,f,r  
f,m,r

a,f,t  
f,m,t

a,m,r  
f,r,t

a,m,t  
m,r,t

6.

$$\binom{n}{2} + \binom{n-1}{2} = \left(\frac{1}{2}\right)(n)(n-1) + \left(\frac{1}{2}\right)(n-1)(n-2) = \left(\frac{1}{2}\right)(n-1)[n + (n-2)] = \left(\frac{1}{2}\right)(n-1)(2n-2) = (n-1)^2.$$

7. (a)  $\binom{20}{12}$

(b)  $\binom{10}{6} \binom{10}{6}$

(c)  $\binom{10}{2} \binom{10}{10} (2 \text{ women}) + \binom{10}{4} \binom{10}{8} (4 \text{ women}) + \dots + \binom{10}{10} \binom{10}{2} (10 \text{ women}) = \sum_{i=1}^5 \binom{10}{2i} \binom{10}{12-2i}$

(d)  $\binom{10}{7} \binom{10}{5} (7 \text{ women}) + \binom{10}{8} \binom{10}{4} (8 \text{ women}) + \binom{10}{9} \binom{10}{3} (9 \text{ women}) + \binom{10}{10} \binom{10}{2} (10 \text{ women}) = \sum_{i=7}^{10} \binom{10}{i} \binom{10}{12-i}$

(e)  $\sum_{i=8}^{10} \binom{10}{i} \binom{10}{12-i}$

8. (a)  $\binom{4}{1} \binom{13}{5}$

(b)  $\binom{4}{4} \binom{48}{1}$

(c)  $\binom{13}{1} \binom{4}{4} \binom{48}{1}$

(d)  $\binom{4}{3} \binom{4}{2}$

(e)  $\binom{4}{3} \binom{12}{1} \binom{4}{2}$

(f)  $\binom{13}{1} \binom{4}{3} \binom{12}{1} \binom{4}{2} = 3744$

(g)  $\binom{13}{1} \binom{4}{3} \binom{48}{1} \binom{44}{1} / 2$  (Division by 2 is needed since no distinction is made for the order in which the other two cards are drawn.) This result equals  $54,912 = \binom{13}{1} \binom{4}{3} \binom{48}{2} - 3744 = \binom{13}{1} \binom{4}{3} \binom{12}{2} \binom{4}{1} \binom{4}{1}$ .

(h)  $\binom{13}{2} \binom{4}{2} \binom{4}{2} \binom{44}{1}$ .

9. (a)  $\binom{8}{2}$

(b)  $\binom{8}{4}$

(c)  $\binom{8}{6}$

(d)  $\binom{8}{6} + \binom{8}{7} + \binom{8}{8}$ .

10.  $\binom{12}{5}$ ;  $\binom{10}{3}$ .

11. (a)  $\binom{10}{7} = 120$

(b)  $\binom{8}{5} = 56$

(c)  $\binom{6}{4} \binom{4}{3}$  (four of the first six) +  $\binom{6}{5} \binom{4}{2}$

(five of the first six) +  $\binom{6}{6} \binom{4}{1}$  (all of the first six) =  $(15)(4) + (6)(6) + (1)(4) = 100$ .

12. (a) The first three books can be selected in  $\binom{12}{3}$  ways. The next three in  $\binom{9}{3}$  ways. The third set of three in  $\binom{6}{3}$  ways and the fourth set in  $\binom{3}{3}$  ways. Consequently, the 12 books can be distributed in  $\binom{12}{3} \binom{9}{3} \binom{6}{3} \binom{3}{3} = (12!)/[(3!)^4]$  ways.

$$(b) \binom{12}{4} \binom{8}{4} \binom{4}{2} \binom{2}{2} = (12!)/[(4!)^2(2!)^2].$$

13. The letters M, I, I, I, P, P, I can be arranged in  $[7!/(4!)(2!)]$  ways. Each arrangement provides eight locations (one at the start of the arrangement, one at the finish, and six between letters) for placing the four nonconsecutive S's. Four of these locations can be selected in  $\binom{8}{4}$  ways. Hence, the total number of these arrangements is  $\binom{8}{4} [7!/(4!)(2!)]$ .

14.  $\binom{n}{j_1} = 12,376$  when  $n = 17$ .

15. (a) Two distinct points determine a line. With 15 points, no three collinear, there are  $\binom{15}{2}$  possible lines.

(b) There are  $\binom{25}{3}$  possible triangles or planes, and  $\binom{25}{4}$  possible tetrahedra.

16. (a)  $\sum_{i=1}^6 (i^2+1) = (1^2+1)+(2^2+1)+(3^2+1)+(4^2+1)+(5^2+1)+(6^2+1) = 2+5+10+17+26+37 = 97$

(b)  $\sum_{j=-2}^2 (j^3-1) = [(-2)^3-1]+[(-1)^3-1]+(0^3-1)+(1^3-1)+(2^3-1) = -9-2-1+0+7 = -5$

(c)  $\sum_{i=0}^{10} [1+(-1)^i] = 2+0+2+0+2+0+2+0+2+0+2 = 12$

(d)  $\sum_{k=n}^{2n} (-1)^k = [(-1)^n + (-1)^{n+1}] + [(-1)^{n+2} + (-1)^{n+3}] + \dots + [(-1)^{2n-1} + (-1)^{2n}] = 0+0+\dots+0 = 0$

(e)  $\sum_{i=1}^6 i(-1)^i = -1+2-3+4-5+6 = 3$

17. (a)  $\sum_{k=2}^n \frac{1}{k!}$                       (b)  $\sum_{i=1}^7 i^2$                       (c)  $\sum_{j=1}^7 (-1)^{j-1} j^3 = \sum_{k=1}^7 (-1)^{k+1} k^3$

(d)  $\sum_{i=0}^n \frac{i+1}{n+i}$                       (e)  $\sum_{i=0}^n (-1)^i \left[ \frac{n+i}{(2i)!} \right]$

18. (a)  $10!/(4!3!3!)$                       (b)  $\binom{10}{8} 2^2 + \binom{10}{9} 2 + \binom{10}{10}$   
(c)  $\binom{10}{4}$  (four 1's, six 0's) +  $\binom{10}{2} \binom{8}{1}$  (two 1's, one 2, seven 0's) +  $\binom{10}{2}$  (two 2's, eight 0's)

19.  $\binom{10}{3}$  (three 1's, seven 0's) +  $\binom{10}{1} \binom{9}{1}$  (one 1, one 2, eight 0's) +  $\binom{10}{1}$  (one 3, nine 0's) = 220  
 $\binom{10}{4} + \binom{10}{2} + \binom{10}{1} \binom{9}{2} + \binom{10}{1} \binom{9}{1} = 705$

$(2^{10})(\sum_{i=0}^5 \binom{10}{2i})$  - Select an even number of locations for 0,2. This is done in  $\binom{10}{2i}$  ways for  $0 \leq i \leq 5$ . Then for the  $2i$  positions selected there are two choices; for the  $10 - 2i$  remaining positions there are also two choices - namely, 1,3.

20. (a) We can select 3 vertices from A, B, C, D, E, F, G, H in  $\binom{8}{3}$  ways, so there are  $\binom{8}{3} = 56$  distinct inscribed triangles.

(b)  $\binom{8}{4} = 70$  quadrilaterals.

(c) The total number of polygons is  $\binom{8}{3} + \binom{8}{4} + \binom{8}{5} + \binom{8}{6} + \binom{8}{7} + \binom{8}{8} = 2^8 - [(\binom{8}{0} + \binom{8}{1} + \binom{8}{2})] = 256 - [1 + 8 + 28] = 219$ .

21. There are  $\binom{n}{3}$  triangles if sides of the  $n$ -gon may be used. Of these  $\binom{n}{3}$  triangles, when  $n \geq 4$  there are  $n$  triangles that use two sides of the  $n$ -gon and  $n(n-4)$  triangles that use only one side. So if the sides of the  $n$ -gon cannot be used, then there are  $\binom{n}{3} - n - n(n-4)$ ,  $n \geq 4$ , triangles.

22. (a) From the rule of product it follows that there are  $4 \times 4 \times 6 = 96$  terms in the complete expansion of  $(a + b + c + d)(e + f + g + h)(u + v + w + x + y + z)$ .

(b) The terms  $bvx$  and  $egu$  do not occur as summands in this expansion.

23. (a)  $\binom{12}{9}$  (b)  $\binom{12}{9}(2^3)$

(c) Let  $a = 2x$  and  $b = -3y$ . By the binomial theorem the coefficient of  $a^9b^3$  in the expansion of  $(a + b)^{12}$  is  $\binom{12}{9}$ . But  $\binom{12}{9} a^9b^3 = \binom{12}{9}(2x)^9(-3y)^3 = \binom{12}{9}(2^9)(-3)^3 x^9y^3$ , so the coefficient of  $x^9y^3$  is  $\binom{12}{9}(2^9)(-3)^3$ .

$$24. \frac{\binom{n}{n_1} \binom{n-n_1}{n_2} \binom{n-n_1-n_2}{n_3} \dots \binom{n-n_1-n_2-\dots-n_{t-1}}{n_t}}{\binom{n!}{n!(n-n_1)!} \binom{(n-n_1)!}{n_2!(n-n_1-n_2)!} \binom{(n-n_1-n_2)!}{n_3!(n-n_1-n_2-n_3)!} \dots \binom{n_t!}{n_t!0!}} = \frac{n!}{n_1!n_2!n_3!\dots n_t!}$$

$$25. (a) \binom{4}{1,1,2} = 12 \quad (b) \binom{4}{0,1,1,2} = 12$$

$$(c) \binom{4}{1,1,2}(2)(-1)(-1)^2 = -24 \quad (d) \binom{4}{1,1,2}(-2)(3)^2 = -216$$

$$(e) \binom{8}{3,2,1,2}(2)^3(-1)^2(3)(-2)^2 = 161,280$$

$$26. (a) \binom{10}{2,2,2,2,2} = (10!)/(2!)^5 = 113,400$$

$$(b) \binom{12}{2,2,2,2,4}(2)^2(-1)^2(3)^2(1)^2(-2)^4 = [(12!)/((2!)^4(4!))](2)^2(3)^2(2)^4 = 718,502,400$$

$$(c) \binom{12}{0,2,2,2,2,4}(1)^2(-2)^2(1)^2(5)^2(3)^4 = [(12!)/(0!(2!)^4(4!))](2)^2(5)^2(3)^4 = 10,103,940,000$$

27. In each of parts (a)-(e) replace the variables by 1 and evaluate the results.

$$(a) 2^3 \quad (b) 2^{10} \quad (c) 3^{10} \quad (d) 4^5 \quad (e) 4^{10}$$

$$28. \text{ a) } \sum_{i=0}^n \frac{1}{i!(n-i)!} = \frac{1}{n!} \sum_{i=0}^n \frac{n!}{i!(n-i)!} = \frac{1}{n!} \sum_{i=0}^n \binom{n}{i} = 2^n/n!$$

$$\text{ b) } \sum_{i=0}^n \frac{(-1)^i}{i!(n-i)!} = \frac{1}{n!} \sum_{i=0}^n \frac{(-1)^i n!}{i!(n-i)!} = \frac{1}{n!} \sum_{i=0}^n (-1)^i \binom{n}{i} = \frac{1}{n!} (0) = 0.$$

$$29. \quad n \binom{m+n}{m} = n \frac{(m+n)!}{m!n!} = \frac{(m+n)!}{m!(n-1)!} = \\ (m+1) \frac{(m+n)!}{(m+1)(m!)(n-1)!} = (m+1) \frac{(m+n)!}{(m+1)!(n-1)!} = (m+1) \binom{m+n}{m+1}$$

30. The sum is the binomial expansion of  $(1+2)^n = 3^n$ .

$$31. \text{ (a) } 1 = [(1+x) - x]^n = (1+x)^n - \binom{n}{1}x^1(1+x)^{n-1} + \binom{n}{2}x^2(1+x)^{n-2} - \dots + (-1)^n \binom{n}{n}x^n.$$

$$\text{ (b) } 1 = [(2+x) - (x+1)]^n \qquad \text{ (c) } 2^n = [(2+x) - x]^n$$

$$32. \quad \sum_{i=0}^{50} \binom{50}{i} 8^i = (1+8)^{50} = 9^{50} = [(\pm 3)^2]^{50} = (\pm 3)^{100}, \text{ so } x = \pm 3.$$

$$33. \text{ (a) } \sum_{i=1}^3 (a_i - a_{i-1}) = (a_1 - a_0) + (a_2 - a_1) + (a_3 - a_2) = a_3 - a_0$$

$$\text{ (b) } \sum_{i=1}^n (a_i - a_{i-1}) = (a_1 - a_0) + (a_2 - a_1) + (a_3 - a_2) + \dots + (a_{n-1} - a_{n-2}) + (a_n - a_{n-1}) = \\ a_n - a_0$$

$$\text{ (c) } \sum_{i=1}^{100} \left( \frac{1}{i+2} - \frac{1}{i+1} \right) = \left( \frac{1}{3} - \frac{1}{2} \right) + \left( \frac{1}{4} - \frac{1}{3} \right) + \left( \frac{1}{5} - \frac{1}{4} \right) + \dots + \left( \frac{1}{101} - \frac{1}{100} \right) + \left( \frac{1}{102} - \frac{1}{101} \right) = \\ \frac{1}{102} - \frac{1}{2} = \frac{1-51}{102} = \frac{-50}{102} = \frac{-25}{51}.$$

34.

**procedure** *Select2*(*i,j*: positive integers)

**begin**

**for** *i* := 1 to 5 **do**

**for** *j* := *i* + 1 to 6 **do**

**print** (*i,j*)

**end**

**procedure** *Select3*(*i,j,k*: positive integers)

**begin**

**for** *i* := 1 to 4 **do**

**for** *j* := *i* + 1 to 5 **do**

**for** *k* := *j* + 1 to 6 **do**

**print** (*i,j,k*)

**end**

## Section 1.4

- Let  $x_i, 1 \leq i \leq 5$ , denote the amounts given to the five children.
  - The number of integer solutions of  $x_1 + x_2 + x_3 + x_4 + x_5 = 10, 0 \leq x_i, 1 \leq i \leq 5$ , is  $\binom{5+10-1}{10} = \binom{14}{10}$ . Here  $n = 5, r = 10$ .
  - Giving each child one dime results in the equation  $x_1 + x_2 + x_3 + x_4 + x_5 = 5, 0 \leq x_i, 1 \leq i \leq 5$ . There are  $\binom{5+5-1}{5} = \binom{9}{5}$  ways to distribute the remaining five dimes.
  - Let  $x_5$  denote the amount for the oldest child. The number of solutions to  $x_1 + x_2 + x_3 + x_4 + x_5 = 10, 0 \leq x_i, 1 \leq i \leq 4, 2 \leq x_5$  is the number of solutions to  $y_1 + y_2 + y_3 + y_4 + y_5 = 8, 0 \leq y_i, 1 \leq i \leq 5$ , which is  $\binom{5+8-1}{8} = \binom{12}{8}$ .
- Let  $x_i, 1 \leq i \leq 5$ , denote the number of candy bars for the five children with  $x_1$  the number for the youngest.  $(x_1 = 1): x_2 + x_3 + x_4 + x_5 = 14$ . Here there are  $\binom{4+14-1}{14} = \binom{17}{14}$  distributions.  $(x_1 = 2): x_2 + x_3 + x_4 + x_5 = 13$ . Here the number of distributions is  $\binom{4+13-1}{13} = \binom{16}{13}$ . The answer is  $\binom{17}{14} + \binom{16}{13}$  by the rule of sum.
- $\binom{4+20-1}{20} = \binom{23}{20}$
- $\binom{31}{12}$
  - $\binom{31+12-1}{12} = \binom{42}{12}$
  - There are 31 ways to have 12 cones with the same flavor. So there are  $\binom{42}{12} - 31$  ways to order the 12 cones and have at least two flavors.
- $2^5$
  - For each of the  $n$  distinct objects there are two choices. If an object is not selected, then one of the  $n$  identical objects is used in the selection. This results in  $2^n$  possible selections of size  $n$ .
- $\binom{12}{4,4,4} \binom{22}{12}$
- $\binom{4+32-1}{32} = \binom{35}{32}$
  - $\binom{4+28-1}{28} = \binom{31}{28}$
  - $\binom{4+8-1}{8} = \binom{11}{8}$
  - 1
  - $x_1 + x_2 + x_3 + x_4 = 32, x_i \geq -2, 1 \leq i \leq 4$ . Let  $y_i = x_i + 2, 1 \leq i \leq 4$ . The number of solutions to the given problem is then the same as the number of solutions to  $y_1 + y_2 + y_3 + y_4 = 40, y_i \geq 0, 1 \leq i \leq 4$ . This is  $\binom{4+40-1}{40} = \binom{43}{40}$ .
  - $\binom{4+28-1}{28} - \binom{4+3-1}{3} = \binom{31}{28} - \binom{6}{3}$ , where the term  $\binom{6}{3}$  accounts for the solutions where  $x_4 \geq 26$ .
- For the chocolate donuts there are  $\binom{3+5-1}{5} = \binom{7}{5}$  distributions. There are  $\binom{3+4-1}{4} = \binom{6}{4}$  ways to distribute the jelly donuts. By the rule of product there are  $\binom{7}{5} \binom{6}{4}$  ways to distribute the donuts as specified.
- $230, 230 = \binom{n+20-1}{20} = \binom{n+19}{20} \implies n = 7$

10. Here we want the number of integer solutions for  $x_1 + x_2 + x_3 + x_4 + x_5 + x_6 = 100$ ,  $x_i \geq 3$ ,  $1 \leq i \leq 6$ . (For  $1 \leq i \leq 6$ ,  $x_i$  counts the number of times the face with  $i$  dots is rolled.) This is equal to the number of nonnegative integer solutions there are to  $y_1 + y_2 + y_3 + y_4 + y_5 + y_6 = 82$ ,  $y_i \geq 0$ ,  $1 \leq i \leq 6$ . Consequently the answer is  $\binom{6+82-1}{82} = \binom{87}{82}$ .
11. (a)  $\binom{10+5-1}{5} = \binom{14}{5}$  (b)  $\binom{7+5-1}{5} + 3\binom{7+4-1}{4} + 3\binom{7+3-1}{3} + \binom{7+2-1}{2} = \binom{11}{5} + 3\binom{10}{4} + 3\binom{9}{3} + \binom{8}{2}$ , where the first summand accounts for the case where none of 1,3,7 appears, the second summand for when exactly one of 1,3,7 appears once, the third summand for the case of exactly two of these digits appearing once each, and the last summand for when all three appear.
12. (a) The number of solutions for  $x_1 + x_2 + \dots + x_5 < 40$ ,  $x_i \geq 0$ ,  $1 \leq i \leq 5$ , is the same as the number for  $x_1 + x_2 + \dots + x_5 \leq 39$ ,  $x_i \geq 0$ ,  $1 \leq i \leq 5$ , and this equals the number of solutions for  $x_1 + x_2 + \dots + x_5 + x_6 = 39$ ,  $x_i \geq 0$ ,  $1 \leq i \leq 6$ . There are  $\binom{6+39-1}{39} = \binom{44}{39}$  such solutions.  
 (b) Let  $y_i = x_i + 3$ ,  $1 \leq i \leq 5$ , and consider the inequality  $y_1 + y_2 + \dots + y_5 \leq 54$ ,  $y_i \geq 0$ . There are [as in part (a)]  $\binom{6+54-1}{54} = \binom{59}{54}$  solutions.
13. (a)  $\binom{4+4-1}{4} = \binom{7}{4}$ .  
 (b)  $\binom{3+7-1}{7}$  (container 4 has one marble)  $+ \binom{3+5-1}{5}$  (container 4 has three marbles)  $+ \binom{3+3-1}{3}$  (container 4 has five marbles)  $+ \binom{3+1-1}{1}$  (container 4 has seven marbles)  $= \sum_{i=0}^3 \binom{9-2i}{7-2i}$ .
14. (a)  $\binom{8}{2,4,1,0,1} (3)^2 (2)^4$   
 (b) The terms in the expansion have the form  $v^a w^b x^c y^d z^e$  where  $a, b, c, d, e$  are nonnegative integers that sum to 8. There are  $\binom{5+8-1}{8} = \binom{12}{8}$  terms.
15. Consider one such distribution - the one where there are six books on each of the four shelves. Here there are  $24!$  ways for this to happen. And we see that there are also  $24!$  ways to place the books for any other such distribution.

The number of distributions is the number of positive integer solutions to

$$x_1 + x_2 + x_3 + x_4 = 24.$$

This is the same as the number of nonnegative integer solutions for

$$y_1 + y_2 + y_3 + y_4 = 20.$$

[Here  $y_i + 1 = x_i$  for all  $1 \leq i \leq 4$ .]

So there are  $\binom{4+20-1}{20} = \binom{23}{20}$  such distributions of the books, and consequently,  $\binom{23}{20} (24!)$  ways in which Beth can arrange the 24 books on the four shelves with at least one book on each shelf.

16. For equation (1) we need the number of nonnegative integer solutions for  $w_1 + w_2 + w_3 + \dots + w_{19} = n - 19$ , where  $w_i \geq 0$  for all  $1 \leq i \leq 19$ . This is  $\binom{19+(n-19)-1}{(n-19)} = \binom{n-1}{n-19}$ . The number of positive integer solutions for equation (2) is the number of nonnegative integer solutions for

$$z_1 + z_2 + z_3 + \dots + z_{64} = n - 64,$$

and this is  $\binom{64+(n-64)-1}{(n-64)} = \binom{n-1}{n-64}$ .

So  $\binom{n-1}{n-19} = \binom{n-1}{n-64} = \binom{n-1}{63}$  and  $n - 19 = 63$ . Hence  $n = 82$ .

17. (a)  $\binom{5+12-1}{12} = \binom{16}{12}$  (b)  $5^{12}$
18. (a) There are  $\binom{3+6-1}{6} = \binom{8}{6}$  solutions for  $x_1 + x_2 + x_3 = 6$  and  $\binom{4+31-1}{31} = \binom{34}{31}$  solutions for  $x_4 + x_5 + x_6 + x_7 = 31$ , where  $x_i \geq 0$ ,  $1 \leq i \leq 7$ . By the rule of product the pair of equations has  $\binom{8}{6} \binom{34}{31}$  solutions.
- (b)  $\binom{5}{3} \binom{34}{31}$
19. Here there are  $r = 4$  nested for loops, so  $1 \leq m \leq k \leq j \leq i \leq 20$ . We are making selections, with repetition, of size  $r = 4$  from a collection of size  $n = 20$ . Hence the print statement is executed  $\binom{20+4-1}{4} = \binom{23}{4}$  times.
20. Here there are  $r = 3$  nested for loops and  $1 \leq i \leq j \leq k \leq 15$ . So we are making selections, with repetition, of size  $r = 3$  from a collection of size  $n = 15$ . Therefore the statement

$$\text{counter} := \text{counter} + 1$$

is executed  $\binom{15+3-1}{3} = \binom{17}{3}$  times, and the final value of the variable *counter* is  $10 + \binom{17}{3} = 690$ .

21. The begin-end segment is executed  $\binom{10+3-1}{3} = \binom{12}{3} = 220$  times. After the execution of this segment the value of the variable *sum* is  $\sum_{i=1}^{220} i = (220)(221)/2 = 24,310$ .

22.  $\binom{n+2}{3} = \sum_{i=1}^n \binom{i+1}{2} \implies \frac{(n+2)(n+1)n}{6} = \frac{1}{2} \sum_{i=1}^n (i+1)i \implies \frac{(n+2)(n+1)n}{6} = \frac{1}{2} \sum_{i=1}^n i^2 + \frac{1}{2} \sum_{i=1}^n i \implies \frac{1}{2} \sum_{i=1}^n i^2 = \frac{(n+2)(n+1)n}{6} - \frac{(n+1)n}{4} \implies \sum_{i=1}^n i^2 = n(n+1) \left[ \frac{n+2}{3} - \frac{1}{2} \right] = n(n+1) \left[ \frac{2n+4-3}{6} \right] = \frac{n(n+1)(2n+1)}{6}$ .

23. (a) Put one object into each container. Then there are  $m - n$  identical objects to place into  $n$  distinct containers. This yields  $\binom{n+(m-n)-1}{m-n} = \binom{m-1}{m-n} = \binom{m-1}{n-1}$  distributions.
- (b) Place  $r$  objects into each container. The remaining  $m - rn$  objects can then be distributed among the  $n$  distinct containers in  $\binom{n+(m-rn)-1}{m-rn} = \binom{m-1+(1-r)n}{m-rn} = \binom{m-1+(1-r)n}{n-1}$  ways.

24. (a)

procedure *Selections1*( $i, j$ : nonnegative integers)

```

begin
  for i := 0 to 10 do
    for j := 0 to 10 - i do
      print (i, j, 10 - i - j)
    end
  end
end

```

(b) For all  $1 \leq i \leq 4$  let  $y_i = x_i + 2 \geq 0$ . Then the number of integer solutions to  $x_1 + x_2 + x_3 + x_4 = 4$ , where  $-2 \leq x_i$  for  $1 \leq i \leq 4$ , is the number of integer solutions to  $y_1 + y_2 + y_3 + y_4 = 12$ , where  $y_i \geq 0$  for  $1 \leq i \leq 4$ . We use this observation in the following.

```

procedure Selections(i, j, k: nonnegative integers)
begin
  for i := 0 to 12 do
    for j := 0 to 12 - i do
      for k := 0 to 12 - i - j do
        print (i, j, k, 12 - i - j - k)
      end
    end
  end
end

```

25. If the summands must all be even, then consider one such composition – say,

$$20 = 10 + 4 + 2 + 4 = 2(5 + 2 + 1 + 2).$$

Here we notice that  $5 + 2 + 1 + 2$  provides a composition of 10. Further, each composition of 10, when multiplied through by 2, provides a composition of 20, where each summand is even. Consequently, we see that the number of compositions of 20, where each summand is even, equals the number of compositions of 10 – namely,  $2^{10-1} = 2^9$ .

26. Each such composition can be factored as  $k$  times a composition of  $m$ . Consequently, there are  $2^{m-1}$  compositions of  $n$ , where  $n = mk$  and each summand in a composition is a multiple of  $k$ .

27. a) Here we want the number of integer solutions for  $x_1 + x_2 + x_3 = 12$ ,  $x_1, x_3 > 0$ ,  $x_2 = 7$ . The number of integer solutions for  $x_1 + x_3 = 5$ , with  $x_1, x_3 > 0$ , is the same as the number of integer solutions for  $y_1 + y_3 = 3$ , with  $y_1, y_3 \geq 0$ . This is  $\binom{2+3-1}{3} = \binom{4}{3} = 4$ .

b) Now we must also consider the integer solutions for  $w_1 + w_2 + w_3 = 12$ ,  $w_1, w_3 > 0$ ,  $w_2 = 5$ . The number here is  $\binom{2+5-1}{5} = \binom{6}{5} = 6$ .

Consequently, there are  $4 + 6 = 10$  arrangements that result in three runs.

c) The number of arrangements for four runs requires two cases [as above in part (b)].

If the first run consists of heads, then we need the number of integer solutions for  $x_1 + x_2 + x_3 + x_4 = 12$ , where  $x_1 + x_3 = 5$ ,  $x_1, x_3 > 0$  and  $x_2 + x_4 = 7$ ,  $x_2, x_4 > 0$ . This number is  $\binom{2+3-1}{3} \binom{2+5-1}{5} = \binom{4}{3} \binom{6}{5} = 4 \cdot 6 = 24$ . When the first run consists of tails we get  $\binom{6}{5} \binom{4}{3} = 6 \cdot 4 = 24$  arrangements.

In all there are  $2(24) = 48$  arrangements with four runs.

d) If the first run starts with an H, then we need the number of integer solutions for  $x_1 + x_2 + x_3 + x_4 + x_5 = 12$  where  $x_1 + x_3 + x_5 = 5$ ,  $x_1, x_3, x_5 > 0$  and  $x_2 + x_4 = 7$ ,  $x_2, x_4 > 0$ . This is  $\binom{3+2-1}{2} \binom{2+5-1}{5} = \binom{4}{2} \binom{6}{5} = 36$ . For the case where the first run starts with a T, the number of arrangements is  $\binom{3+4-1}{4} \binom{2+3-1}{3} = \binom{6}{4} \binom{4}{3} = 60$ .

In total there are  $36 + 60 = 96$  ways for these 12 tosses to determine five runs.

e)  $\binom{3+4-1}{4} \binom{3+2-1}{2} = \binom{6}{4} \binom{4}{2} = 90$  - the number of arrangements which result in six runs, if the first run starts with an H. But this is also the number when the first run starts with a T. Consequently, six runs come about in  $2 \cdot 90 = 180$  ways.

f)  $2 \binom{1+4-1}{4} \binom{1+6-1}{6} + 2 \binom{2+3-1}{3} \binom{2+5-1}{5} + 2 \binom{3+2-1}{2} \binom{3+4-1}{4} + 2 \binom{4+1-1}{1} \binom{4+3-1}{3} + 2 \binom{5+0-1}{0} \binom{5+2-1}{2} = 2 \sum_{i=0}^4 \binom{4}{4-i} \binom{6}{6-i} = 2[1 \cdot 1 + 4 \cdot 6 + 6 \cdot 15 + 4 \cdot 20 + 1 \cdot 15] = 420$ .

28. (a) For  $n \geq 4$ , consider the strings made up of  $n$  bits - that is, a total of  $n$  0's and 1's. In particular, consider those strings where there are (exactly) two occurrences of 01. For example, if  $n = 6$  we want to include strings such as 010010 and 100101, but not 101111 or 010101. How many such strings are there?  
 (b) For  $n \geq 6$ , how many strings of  $n$  0's and 1's contain (exactly) three occurrences of 01?  
 (c) Provide a combinatorial proof for the following:

$$\text{For } n \geq 1, \quad 2^n = \binom{n+1}{1} + \binom{n+1}{3} + \cdots + \begin{cases} \binom{n+1}{n}, & n \text{ odd} \\ \binom{n+1}{n+1}, & n \text{ even.} \end{cases}$$

(a) A string of this type consists of  $x_1$  1's followed by  $x_2$  0's followed by  $x_3$  1's followed by  $x_4$  0's followed by  $x_5$  1's followed by  $x_6$  0's, where,

$$x_1 + x_2 + x_3 + x_4 + x_5 + x_6 = n, \quad x_1, x_6 \geq 0, \quad x_2, x_3, x_4, x_5 > 0.$$

The number of solutions to this equation equals the number of solutions to

$$y_1 + y_2 + y_3 + y_4 + y_5 + y_6 = n - 4, \quad \text{where } y_i \geq 0 \text{ for } 1 \leq i \leq 6.$$

This number is  $\binom{6+(n-4)-1}{n-4} = \binom{n+1}{n-4} = \binom{n+1}{5}$ .

(b) For  $n \geq 6$ , a string with this structure has  $x_1$  1's followed by  $x_2$  0's followed by  $x_3$  1's ... followed by  $x_8$  0's, where

$$x_1 + x_2 + x_3 + \cdots + x_8 = n, \quad x_1, x_8 \geq 0, \quad x_2, x_3, \dots, x_7 > 0.$$

The number of solutions to this equation equals the number of solutions to

$$y_1 + y_2 + y_3 + \cdots + y_8 = n - 6, \quad \text{where } y_i \geq 0 \text{ for } 1 \leq i \leq 8.$$

This number is  $\binom{s+(n-6)-1}{n-6} = \binom{n+1}{n-6} = \binom{n+1}{7}$ .

(c) There are  $2^n$  strings in total and  $n+1$  strings where there are  $k$  1's followed by  $n-k$  0's, for  $k = 0, 1, 2, \dots, n$ . These  $n+1$  strings contain no occurrences of 01, so there are  $2^n - (n+1) = 2^n - \binom{n+1}{1}$  strings that contain at least one occurrence of 01. There are  $\binom{n+1}{3}$  strings that contain (exactly) one occurrence of 01,  $\binom{n+1}{5}$  strings with (exactly) two occurrences,  $\binom{n+1}{7}$  strings with (exactly) three occurrences, ... , and for

(i)  $n$  odd, we can have at most  $\frac{n-1}{2}$  occurrences of 01. The number of strings with  $\frac{n-1}{2}$  occurrences of 01 is the number of integer solutions for

$$x_1 + x_2 + \dots + x_{n+1} = n, \quad x_1, x_{n+1} \geq 0, \quad x_2, x_3, \dots, x_n > 0.$$

This is the same as the number of integer solutions for

$$y_1 + y_2 + \dots + y_{n+1} = n - (n-1) = 1, \quad \text{where } y_1, y_2, \dots, y_{n+1} \geq 0.$$

This number is  $\binom{(n+1)+1-1}{1} = \binom{n+1}{1} = \binom{n+1}{n} = \binom{n+1}{2(\frac{n-1}{2})+1}$ .

(ii)  $n$  even, we can have at most  $\frac{n}{2}$  occurrences of 01. The number of strings with  $\frac{n}{2}$  occurrences of 01 is the number of integer solutions for

$$x_1 + x_2 + \dots + x_{n+2} = n, \quad x_1, x_{n+2} \geq 0, \quad x_2, x_3, \dots, x_n > 0.$$

This is the same as the number of integer solutions for

$$y_1 + y_2 + \dots + y_{n+2} = n - n = 0, \quad \text{where } y_i \geq 0 \text{ for } 1 \leq i \leq n+2.$$

This number is  $\binom{(n+2)+0-1}{0} = \binom{n+1}{0} = \binom{n+1}{n+1} = \binom{n+1}{2(\frac{n}{2})+1}$ .

Consequently,

$$2^n - \binom{n+1}{1} = \binom{n+1}{3} + \binom{n+1}{5} + \dots + \begin{cases} \binom{n+1}{n}, & n \text{ odd} \\ \binom{n+1}{n+1}, & n \text{ even,} \end{cases}$$

and the result follows.

## Section 1.5

$$\begin{aligned} \binom{2n}{n} - \binom{2n}{n-1} &= \frac{(2n)!}{n!n!} - \frac{(2n)!}{(n-1)!(n+1)!} = \\ \frac{(2n)!(n+1)}{(n+1)!n!} - \frac{(2n)!n}{n!(n+1)!} &= \frac{(2n)![(n+1)-n]}{(n+1)!n!} = \frac{1}{(n+1)} \frac{(2n)!}{n!n!} = \\ &= \left(\frac{1}{n+1}\right) \binom{2n}{n} \end{aligned}$$

2.  $b_7 = 429$      $b_8 = 1430$      $b_9 = 4862$      $b_{10} = 16796$

3. (a)  $5(= b_3)$ ;  $14(= b_4)$

(b) For  $n \geq 0$  there are  $b_n(= \frac{1}{(n+1)} \binom{2n}{n})$  such paths from  $(0,0)$  to  $(n,n)$ .

(c) For  $n \geq 0$  the first move is  $U$  and the last is  $H$ .

4. (a)  $b_6 = 132$

(b)  $b_5 = 42$

(c)  $b_7 = 429$

5. Using the results in the third column of Table 1.10 we have:

111000

110010

101010

1 2 3

1 2 5

1 3 5

4 5 6

3 4 6

2 4 6

6.

(a) (i) 1 3 4 7  
2 5 6 8

(ii) 1 2 5 7  
3 4 6 8

(iii) 1 2 3 5  
4 6 7 8

(b) (i) 10111000

(ii) 11100010

(iii) 11011000

7. There are  $b_5(= 42)$  ways.

8. (a) (i) 1110001010

(ii) 1010101010

(iii) 1111001000

(b) (i)  $((ab(c(de \leftrightarrow ((ab)(c(de))))f)$

(ii)  $((ab((cd(e \leftrightarrow ((ab)((cd)(ef))))$

(iii)  $(a(((bc(de \leftrightarrow (a(((bc)(de))))f)$

9. (i) When  $n = 4$  there are  $14(= b_4)$  such diagrams.

(ii) For any  $n \geq 0$ , there are  $b_n$  different drawings of  $n$  semicircles on and above a horizontal line, with no two semicircles intersecting. Consider, for instance, the diagram in part (f) of the figure. Going from left to right, write 1 the first time you encounter a semicircle and write 0 the second time that semicircle is encountered. Here we get the list 110100. The list 110010 corresponds with the drawing in part (g). This correspondence shows that the number of such drawings for  $n$  semicircles is the same as the number of lists of  $n$  1's and  $n$  0's where, as the list is read from left to right, the number of 0's never exceeds the number of 1's.

10. (a) In total there are  $\binom{10}{7} = \binom{10}{3}$  paths from  $(0,0)$  to  $(7,3)$ , each made up of seven  $R$ 's and three  $U$ 's. From these  $\binom{10}{7}$  paths we remove those that violate the stated condition – namely, those paths where the number of  $U$ 's exceeds the number  $R$ 's (at some first position in the path). For example, consider one such path:

$RURUURRRRR$ .

Here the condition is violated, for the first time, after the third  $U$ . Transform the given path as follows:

$$RURUU:RRRRR \leftrightarrow RURUUUUUU.$$

Here the entries up to and including the first violation remain unchanged, while those following the first violation are changed:  $R$ 's become  $U$ 's and  $U$ 's become  $R$ 's. This correspondence shows us that the number of paths that violate the given condition is the same as the number of paths made up of eight  $U$ 's and two  $R$ 's – and there are  $\binom{10}{8} = \binom{10}{2}$  such paths.

Consequently, the answer is

$$\binom{10}{7} - \binom{10}{8} = \frac{10!}{7!3!} - \frac{10!}{8!2!} = \frac{10!(8)}{8!3!} - \frac{10!(3)}{8!3!} = \left(\frac{5}{8}\right) \frac{10!}{7!3!} = \left(\frac{7+1-3}{7+1}\right) \binom{10}{7}.$$

$$\begin{aligned} \text{(b)} \quad \binom{m+n}{n} - \binom{m+n}{n+1} &= \frac{(m+n)!}{n!m!} - \frac{(m+n)!}{(n+1)!(m-1)!} \\ &= \frac{(m+n)!(n+1) - (m+n)!m}{(n+1)!m!} = \left(\frac{n+1-m}{n+1}\right) \left(\frac{(m+n)!}{n!m!}\right) = \left(\frac{n+1-m}{n+1}\right) \binom{m+n}{n}. \end{aligned}$$

[Note that when  $m = n$ , this becomes  $\left(\frac{1}{n+1}\right) \binom{2n}{n}$ , the formula for the  $n$ th Catalan number.]

11. Consider one of the  $\left(\frac{1}{6+1}\right) \binom{2 \cdot 6}{6} = \left(\frac{1}{7}\right) \binom{12}{6}$  ways in which the \$5 and \$10 bills can be arranged – say,

$$(*) \quad \$5, \$5, \$10, \$5, \$5, \$10, \$10, \$10, \$5, \$5, \$10, \$10.$$

Here we consider the six \$5 bills as indistinguishable – likewise, for the six \$10 bills. However, we consider the patrons as distinct. Hence, there are  $6!$  ways for the six patrons, each with a \$5 bill, to occupy positions 1, 2, 4, 5, 9, and 10, in the arrangement (\*). Likewise, there are  $6!$  ways to locate the other six patrons (each with a \$10 bill). Consequently, here the number of arrangements is

$$\left(\frac{1}{7}\right) \binom{12}{6} (6!)(6!) = \left(\frac{1}{7}\right) (12!) = 68,428,800.$$

### Supplementary Exercises

1.  $\binom{4}{1} \binom{7}{2} + \binom{4}{2} \binom{7}{4} + \binom{4}{3} \binom{7}{6}$

2. (a)  $5^9$  (b)  $5(4^8)$

3.

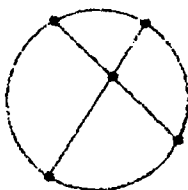

Select any four of these twelve points (on the circumference). As seen in the figure, these points determine a pair of chords that intersect. Consequently, the largest number of points of intersection for all possible chords is  $\binom{12}{4} = 495$ .

4. (a)  $\binom{25}{2}^3$   
 (b)  $3\binom{25}{1}^2\binom{25}{4}$  (four hymns from one book, one from each of the other two) +  $6\binom{25}{1}\binom{25}{2}\binom{25}{3}$  (one hymn from one book, two hymns from a second book, and three from the third book) +  $\binom{25}{2}^3$  (two hymns from each of the three books).

5. (a)  $10^{25}$   
 (b) There are 10 choices for the first flag. For the second flag there are 11 choices: The nine poles with no flag, and above or below the first flag on the pole where it is situated. There are 12 choices for the third flag, 13 choices for the fourth, ..., and 34 choices for the last (25th). Hence there are  $(34!)/(9!)$  possible arrangements.  
 (c) There are  $25!$  ways to arrange the flags. For each arrangement consider the 24 spaces, one between each pair of flags. Selecting 9 of these spaces provides a distribution among the 10 flagpoles where every flagpole has at least one flag and order is relevant. Hence there are  $(25!) \binom{24}{9}$  such arrangements.

6. Consider the 45 heads and the 46 positions they determine: (1) One position to the left of the first head; (2) One position between the  $i$ -th head and the  $(i + 1)$ -st head, where  $1 \leq i \leq 44$ ; and, (3) One position to the right of the 45-th (last) head. To answer the question posed we need to select 15 of the 46 positions. This we can do in  $\binom{46}{15}$  ways.

In an alternate way, let  $x_i$  denote the number of heads to the left of the  $i$ -th tail, for  $1 \leq i \leq 15$ . Let  $x_{16}$  denote the number of heads to the right of the 15th tail. Then we want the number of integer solutions for

$$x_1 + x_2 + x_3 + \dots + x_{15} + x_{16} = 45,$$

where  $x_1 \geq 0$ ,  $x_{16} \geq 0$ , and  $x_i > 0$  for  $2 \leq i \leq 15$ . This is the number of integer solutions for

$$y_1 + y_2 + y_3 + \dots + y_{15} + y_{16} = 31,$$

with  $y_i \geq 0$  for  $1 \leq i \leq 16$ . Consequently the answer is  $\binom{16+31-1}{31} = \binom{46}{31} = \binom{46}{15}$ .

7. (a)  $C(12, 8)$  (b)  $P(12, 8)$

8. There are  $(7!/2!)$  ways to arrange the seven symbols OE, W, N, N, D, R, G. In each arrangement there are 6 locations for the I so that it is not adjacent to a vowel, so there are  $(6)(7!/2!)$  arrangements. The three vowels can be divided up into a pair and a single vowel in six ways (order counts), so the total number of arrangements is  $(6^2)(7!/2!)$ .

9. (a) There are two blocks, for example, that differ only in size. There are four that differ only in color, one that differs only in the material used for construction, and five that differ only in shape. In total there are  $2 + 4 + 1 + 5 = 12$  blocks that differ from the *small red wooden square* block in exactly one way.

(b) There are  $\binom{4}{2} = 6$  ways of selecting the two differing properties. Each such pair must be considered separately.

- (i) Material, size: Here there are  $1 \times 2 = 2$  such blocks.
- (ii) Material, color: This pair yields  $1 \times 4 = 4$  such blocks.
- (iii) Material, shape: For this pair we obtain  $1 \times 5 = 5$  such blocks.
- (iv) Size, color: Here we get  $2 \times 4 = 8$  of the blocks.
- (v) Size, shape: This pair gives us  $2 \times 5 = 10$  such blocks.
- (vi) Color, shape: For this pair we find  $4 \times 5 = 20$  of the blocks we need to count.

In total there are  $2 + 4 + 5 + 8 + 10 + 20 = 49$  of Dustin's blocks that differ from the *large blue plastic hexagonal* block in exactly two ways.

10. Since 'R' is the 18th letter of the alphabet, the first and middle initials can be chosen in  $\binom{17}{2} = (17)(16)/2 = 136$  ways.

Alternately, since 'R' is the 18th letter of the alphabet, consider what happens when the middle initial is any letter between 'B' and 'Q'. For middle initial 'Q' there are 16 possible first initials. For middle initial 'P' there are 15 possible choices. Continuing back to 'B' where there is only one choice (namely 'A') for the first initial, we find that the total number of choices is  $1 + 2 + 3 + \dots + 15 + 16 = (16)(17)/2 = 136$ .

11. The number of linear arrangements of the 11 horses is  $11!/(5!3!3!)$ . Each circular arrangement represents 11 linear arrangements, so there are  $(1/11)[11!/(5!3!3!)]$  ways to arrange the horses on the carousel.

12. (a)  $P(16, 12)$  (b)  $\binom{12}{2} P(15, 10)$

13. (a) (i)  $\binom{5}{4} + \binom{5}{2}\binom{4}{2} + \binom{4}{4}$  (ii)  $\binom{5+4-1}{4} + \binom{5+2-1}{2}\binom{4+2-1}{2} + \binom{4+4-1}{4} = \binom{8}{4} + \binom{6}{2}\binom{5}{2} + \binom{7}{4} - 9$   
 (b) (i)  $\binom{5}{1}\binom{4}{3} + \binom{5}{3}\binom{4}{1}$  (ii) and (iii)  $\binom{5}{1}\binom{4+3-1}{3} + \binom{5+3-1}{3}\binom{4}{1} = \binom{5}{1}\binom{6}{3} + \binom{7}{3}\binom{4}{1}$

14. (a) If there are no restrictions Mr. Kelly can make the assignments in  $12! = 479,001,600$  ways.

(b) Mr. DiRocco and Mr. Fairbanks can be assigned in  $4 \times 3 = 12$  ways, and the other 10 assistants can then be assigned in  $10!$  ways. Consequently, in this situation, Mr. Kelly can make one of  $12(10!) = 43,545,600$  assignments.

(c) Suppose that Mr. Hyland is assigned to the first floor and Mr. Thornhill is assigned to the third floor. This can be accomplished in  $4 \times 4 \times (10!) = 58,060,800$  ways. There are  $3 \times 2 = 6$  ways to assign these two assistants to different floors, so in this case we have  $(3 \times 2) \times [4 \times 4 \times (10!)] = 348,364,800$  possibilities.

Alternately, from part (b), there are  $3 \times [12(10!)] = 130,636,800$  ways in which Mr. Hyland and Mr. Thornhill could be assigned to the same floor — and  $(12!) - [(3)(12)(10!)] = 348,364,800$ .

15. (a) For each increasing four-digit integer we have four distinct digits, which can only be arranged in one way. These four digits can be chosen in  $\binom{9}{4} = 126$  ways. And these same

four digits can also be arranged as a decreasing four-digit integer.

To complete the solution we must account for the decreasing four-digit integers where the units digit is 0. There are  $\binom{9}{3} = 84$  of these.

Consequently there are  $2\binom{9}{4} + \binom{9}{3} = 343$  such four-digit integers.

(b) For each nondecreasing four-digit integer we have four nonzero digits, with repetitions allowed. These four digits can be selected in  $\binom{9+4-1}{4} = \binom{12}{4}$  ways. And these same four digits account for a nonincreasing four-digit integer. So at this point we have  $2\binom{12}{4} - 9$  of the four-digit integers we want to count. (The reason we subtract 9 is because we have counted the nine integers 1111, 2222, 3333, ..., 9999 twice in  $2\binom{12}{4}$ .)

We have not accounted for those nonincreasing four-digit integers where the units digit is 0. There are  $\binom{10+3-1}{3} - 1 = \binom{12}{3} - 1$  of these four-digit integers. (Here we subtracted 1 since we do not want to include 0000.)

Therefore there are  $[2\binom{12}{4} - 9] + [\binom{12}{3} - 1] = [2\binom{12}{4} + \binom{12}{3}] - 10 = 1200$  such four-digit integers.

16. (a)  $\binom{5}{2,1,2}(1/2)^2(-3)^2 = 135/2$   
 (b) Each term is of the form  $x^{n_1}y^{n_2}z^{n_3}$  where each  $n_i$ ,  $1 \leq i \leq 3$ , is a nonnegative integer and  $n_1 + n_2 + n_3 = 5$ . Consequently, there are  $\binom{3+5-1}{5} = \binom{7}{5}$  terms.  
 (c) Replace  $x, y$ , and  $z$  by 1. Then the sum of all the coefficients in the expansion is  $((1/2) + 1 - 3)^5 = (-3/2)^5$ .
17. (a) First place person A at the table. There are five distinguishable places available for A (e.g., any of the positions occupied by A,B,C,D,E in Fig. 1.11(a)). Then position the other nine people relative to A. This can be done in  $9!$  ways, so there are  $(5)(9!)$  seating arrangements.  
 (b) There are three distinct ways to position A,B so that they are seated on longer sides of the table across from each other. The other eight people can then be located in  $8!$  different ways, so the total number of arrangements is  $(3)(8!)$ .
18. (a) For  $x_1 + x_2 + x_3 = 6$  there are  $\binom{3+6-1}{6} = \binom{8}{6}$  nonnegative integer solutions. With  $x_1 + x_2 + x_3 = 6$  and  $x_1 + x_2 + x_3 + x_4 + x_5 = 15$ , the number of nonnegative integer solutions for  $x_4 + x_5 = 9$  is  $\binom{2+9-1}{9} = \binom{10}{9}$ . The number of solutions for the pair of equations is  $\binom{8}{6}\binom{10}{9}$ .  
 (b) Let  $0 \leq k \leq 6$ . For  $x_1 + x_2 + x_3 = k$  there are  $\binom{3+k-1}{k} = \binom{k+2}{k}$  solutions. To solve  $x_4 + x_5 \leq 15 - k$ , consider  $x_4 + x_5 + x_6 = 15 - k$ ,  $x_4, x_5, x_6 \geq 0$ . Here there are  $\binom{3+15-k-1}{15-k} = \binom{17-k}{15-k}$  solutions. The total number of solutions is  $\sum_{k=0}^6 \binom{k+2}{k} \binom{17-k}{15-k}$ .
19. (a) Here A must win set 5 and exactly two of the four earlier sets. This can be done in  $\binom{4}{2}$  ways. With seven possible scores for each set there are  $\binom{4}{2}7^5$  ways for the scores to be recorded.

- (b) Here A can win in four sets in  $\binom{3}{2}$  ways, and scores can be recorded in  $\binom{3}{2}7^4$  ways. So if A wins in four or five sets, then the scores can be recorded in  $[\binom{3}{2}7^4 + \binom{4}{2}7^5]$  ways. Since B may be the winner, the final answer is  $2[\binom{3}{2}7^4 + \binom{4}{2}7^5]$ .
20. We can choose  $r$  objects from  $n$  in  $\binom{n}{r}$  ways. Once the  $r$  objects are selected they can be arranged in a circle in  $(r-1)!$  ways. So there are  $\binom{n}{r}(r-1)!$  circular arrangements of the  $n$  objects taken  $r$  at a time.
21. For every positive integer  $n$ ,  $0 = (1-1)^n = \binom{n}{0}(1)^0 - \binom{n}{1}(1)^1 + \binom{n}{2}(1)^2 - \binom{n}{3}(1)^3 + \dots + (-1)^n \binom{n}{n}(1)^n$ , and  $\binom{n}{0} + \binom{n}{2} + \binom{n}{4} + \dots = \binom{n}{1} + \binom{n}{3} + \binom{n}{5} + \dots$
22. (a)  $7!/3!$  (b)  $5!$  (c)  $\binom{5}{3}(4!)$
23. (a) There are  $P(20, 12) = \frac{20!}{8!} = (20)(19)(18)\dots(11)(10)(9)$  ways in which Francesca can fill her bookshelf.  
 (b) There are  $\binom{17}{9}$  ways in which Francesca can select nine other books. Then she can arrange those nine books and the three books on tennis on her bookshelf in  $12!$  ways. Consequently, among the arrangements in part (a), there are  $\binom{17}{9}(12!)$  arrangements that include Francesca's three books on tennis.
24. Following the execution of this program segment the value of *counter* is  
 $10 + (12-1+1)(r-1+1)(2) + [3+4+\dots+(s-3+1)](4) + (12-3+1)(6) + (t-7+1)(8) =$   
 $10 + (12)(r)(2) + [(1/2)(s-3+1)(s-3+2) - 2-1](4) + (10)(6) + (t-6)(8) =$   
 $22 + 24r + 8t + 2(s-2)(s-1) - 12 = 14 + 24r + 8t + 2s(s-3).$
25. (a) For 17 there must be an odd number, between 1 and 17 inclusive, of 1's. For  $2k+1$  1's, where  $0 \leq k \leq 8$ , there are  $2k+2$  locations to select, with repetitions allowed. The selection size is the number of 2's, which is  $(1/2)[17-(2k+1)] = 8-k$ . The selection can be made in  $\binom{2k+2+(8-k)-1}{8-k} = \binom{9+k}{8-k}$  ways, and so the answer is  $\sum_{k=0}^8 \binom{9+k}{8-k} = 2584$ .  
 (b) In the case of 18 the number of 1's must be even:  $2k$ , for  $0 \leq k \leq 9$ . If there are  $2k$  1's, there are  $2k+1$  locations, with repetitions allowed, for the  $(1/2)(18-2k) = 9-k$  2's. The selection can be made in  $\binom{2k+1+(9-k)-1}{9-k} = \binom{9+k}{9-k}$  ways, and the answer is  $\sum_{k=0}^9 \binom{9+k}{9-k} = 4181$ .  
 (c) For  $n$  odd, let  $n = 2k+1$  for  $k \geq 0$ . The number of ways to write  $n$  as an ordered sum of 1's and 2's is  $\sum_{i=0}^k \binom{k+1+i}{k-i}$ .  
 For  $n$  even, let  $n = 2k$  for  $k \geq 1$ . Here the answer is  $\sum_{i=1}^k \binom{k+i}{k-i}$ .
26. (a) (i)  $1$  (one 3) +  $1$  (three 3's) +  $1$  (five 3's) = 3.  
 (ii)  $\binom{8}{1}$  (one 3) +  $\binom{7}{3}$  (three 3's) +  $\binom{6}{5}$  (five 3's).  
 (b) (i)  $1$  (no 3's) +  $1$  (two 3's) +  $1$  (four 3's) +  $1$  (six 3's) = 4.  
 (ii)  $\binom{9}{0}$  (no 3's) +  $\binom{8}{2}$  (two 3's) +  $\binom{7}{4}$  (four 3's) +  $\binom{6}{6}$  (six 3's).

27. (a) The number of positive integer solutions to the given equation is the same as the number of nonnegative integer solutions for  $y_1 + y_2 + \dots + y_r = n - r$ , where  $y_i \geq 0$  for all  $1 \leq i \leq r$ . Here there are  $\binom{r+(n-r)-1}{n-r} = \binom{n-1}{n-r} = \binom{n-1}{r-1}$  solutions.
- (b) The total is  $\sum_{r=1}^n \binom{n-1}{r-1} = \binom{n-1}{0} + \binom{n-1}{1} + \dots + \binom{n-1}{n-1} = 2^{n-1}$ .

28. (a) There are  $5 - 1 = 4$  horizontal moves and  $9 - 2 = 7$  vertical moves. One can arrange 4 R's and 7 U's in  $11!/(4!7!)$  ways.
- (b) Since a diagonal move takes the place of one horizontal move and one vertical move, the number of diagonal moves is between 0 and 4, inclusive. The resulting cases are as follows:

(0 D's):	4 R's, 7 U's:	$11!/(4!7!)$
(1 D's):	3 R's, 6 U's:	$10!/(1!3!6!)$
(2 D's):	2 R's, 5 U's:	$9!/(2!2!5!)$
(3 D's):	1 R, 4 U's:	$8!/(3!1!4!)$
(4 D's):	0 R's, 3 U's:	$7!/(4!0!3!)$

The answer is the sum of the results:  $\sum_{i=0}^4 [(11-i)!/(i!(4-i)!(7-i)!)]$ .

20. (a)  $11!/(7!4!)$
- (b)  $[11!/(7!4!)] - [4!/(2!2!)] [4!/(3!1!)]$
- (c)  $[11!/(7!4!)] + [10!/(6!3!1!)] + [9!/(5!2!2!)] + [8!/(4!1!3!)] + [7!/(3!0!4!)]$  (for part (a))  
 $\{[11!/(7!4!)] + [10!/(6!3!1!)] + [9!/(5!2!2!)] + [8!/(4!1!3!)] + [7!/(3!0!4!)]\} -$   
 $\{[4!/(2!2!)] + [3!/(1!1!1!)] + [2!/2!]\} \times \{[4!/(3!1!)] + [3!/(2!1!)]\}$  (for part (b)).

30. Here we want certain paths from (1,1) to (14,4) where the moves are of the form:
- $(m, n) \rightarrow (m+1, n+1)$ , if the  $(n+1)$ -st ballot is for Katalin.
- $(m, n) \rightarrow (m+1, n-1)$ , if the  $(n+1)$ -st ballot is for Donna.

These paths are the ones that never touch or cross the horizontal (or  $x$ -) axis. In general, an ordered pair  $(m, n)$  here indicates that  $m$  ballots have been counted with Katalin leading by  $n$  votes. The number of ways to count the ballots according to the prescribed conditions is

$$\binom{13}{8} - \binom{13}{9} = 1287 - 715 = 572.$$

31. Each rectangle (contained within the  $8 \times 5$  grid) is determined by four corners of the form  $(a, b), (c, b), (c, d), (a, d)$ , where  $a, b, c, d$  are integers with  $0 \leq a < c \leq 8$  and  $0 \leq b < d \leq 5$ . We can select the pair  $a, c$  in  $\binom{9}{2}$  ways and the pair  $b, d$  in  $\binom{6}{2}$  ways. Consequently, the number of rectangles is  $\binom{9}{2} \binom{6}{2} = 540$ .

32. Here we consider the number of integer solutions for

$$x_1 + x_2 + x_3 = 6, \quad x_i > 0, \quad 1 \leq i \leq 3, \quad \text{and} \quad w_1 + w_2 = 6, \quad w_i > 0, \quad 1 \leq i \leq 2.$$

This equals the number of integer solutions for

$$y_1 + y_2 + y_3 = 3, \quad y_i \geq 0, \quad 1 \leq i \leq 3, \quad \text{and} \quad z_1 + z_2 = 3, \quad z_i \geq 0, \quad 1 \leq i \leq 2.$$

So the answer is  $\binom{3+3-1}{3} \binom{2+3-1}{3} = \binom{5}{3} \binom{4}{3}$ .

- 33.** There are  $\binom{6}{4} = 15$  ways to choose the four quarters when Hunter will take these electives. For each of these choices of four quarters, there are  $12 \cdot 11 \cdot 10 \cdot 9$  ways to assign the electives. So, in total, there are  $\binom{6}{4} \cdot 12 \cdot 11 \cdot 10 \cdot 9 = 178,200$  ways for Hunter to select and schedule these four electives.
- 34.** Consider the family as one unit. Then we are trying to arrange nine distinct objects - the family and the eight other people - around the table. This can be done in  $8!$  ways. Since the family unit can be arranged in four ways, the total number of arrangements under the prescribed conditions is  $4(8!)$ .

CHAPTER 2  
FUNDAMENTALS OF LOGIC

**Section 2.1**

1. The sentences in parts (a), (c), (d), and (f) are statements.
2. The statements in parts (a), (c), and (f) are primitive statements.
3. Since  $p \rightarrow q$  is false the truth value for  $p$  is 1 and that of  $q$  is 0. Consequently, the truth values for the given compound statements are
 

(a) 0    (b) 0    (c) 1    (d) 0
4. (a)  $r \rightarrow q$     (b)  $q \rightarrow p$     (c)  $(s \wedge r) \rightarrow q$
5. (a) If triangle ABC is equilateral, then it is isosceles.  
 (b) If triangle ABC is not isosceles, then it is not equilateral.  
 (c) Triangle ABC is equilateral if and only if it is equiangular.  
 (d) Triangle ABC is isosceles but it is not equilateral.  
 (e) If triangle ABC is equiangular, then it is isosceles.
6. (a) True (1)    (b) False (0)    (c) True (1)
7. (a) If Darci practices her serve daily then she will have a good chance of winning the tennis tournament.  
 (c) If Mary is to be allowed on Larry's motorcycle, then she must wear her helmet.

8.

$p$	$q$	$p \vee q$	(a) $\neg(p \vee \neg q) \rightarrow \neg p$	$p \rightarrow q$	$q \rightarrow p$	(d) $(p \rightarrow q) \rightarrow (q \rightarrow p)$
0	0	0	1	1	1	1
0	1	1	1	1	0	0
1	0	1	1	0	1	1
1	1	1	1	1	1	1

$p$	$q$	$p \rightarrow q$	$p \wedge (p \rightarrow q)$	(e) $[p \wedge (p \rightarrow q)] \rightarrow q$	(f)	(g)
0	0	1	0	1	1	0
0	1	1	0	1	1	1
1	0	0	0	1	1	0
1	1	1	1	1	1	0

$p$	$q$	$r$	$q \rightarrow r$	(b) $p \rightarrow (q \rightarrow r)$	$p \rightarrow q$	(c) $(p \rightarrow q) \rightarrow r$	(h)
0	0	0	1	1	1	0	1
0	0	1	1	1	1	1	1
0	1	0	0	1	1	0	1
0	1	1	1	1	1	1	1
1	0	0	1	1	0	1	1
1	0	1	1	1	0	1	1
1	1	0	0	0	1	0	1
1	1	1	1	1	1	1	1

9. Propositions (a), (e), (f), and (h) are tautologies.

10.

$p$	$q$	$r$	$\overbrace{p \rightarrow (q \rightarrow r)}^s$	$\overbrace{(p \rightarrow q) \rightarrow (p \rightarrow r)}^t$	$s \rightarrow t$
0	0	0	1	1	1
0	0	1	1	1	1
0	1	0	1	1	1
0	1	1	1	1	1
1	0	0	1	1	1
1	0	1	1	1	1
1	1	0	0	0	1
1	1	1	1	1	1

11. (a)  $2^5 = 32$

(b)  $2^n$

12. (a)  $[(p \wedge q) \wedge r] \rightarrow (s \vee t)$  is false (0) when  $(p \wedge q) \wedge r$  is true (1) and  $s \vee t$  is false (0). Hence  $p, q,$  and  $r$  must be true (1) while  $s$  and  $t$  must be false (0).

13.  $p : 0; r : 0; s : 0$

14. (a)  $n = 9$

(b)  $n = 19$

(c)  $n = 19$

15. (a)  $m = 3, n = 6$  (b)  $m = 3, n = 9$  (c)  $m = 18, n = 9$   
 (d)  $m = 4, n = 9$  (e)  $m = 4, n = 9$

16. (a)  $10^2 - 10 = 90$  (b)  $20^2 - 20 = 380$   
 (c)  $(10)(20) - 10 = 190$  (d)  $(20)(10) - 10 = 190$

17. Consider the following possibilities:

- (i) Suppose that either the first or the second statement is the true one. Then statements (3) and (4) are false — so their negations are true. And we find from (3) that Tyler did not eat the piece of pie — while from (4) we conclude that Tyler did eat the pie.
- (ii) Now we'll suppose that statement (3) is the only true statement. So statements (3) and (4) no longer contradict each other. But now statement (2) is false, and we have Dawn

guilty (from statement (2)) and Tyler guilty (from statement (3)).

(iii) Finally, consider the last possibility — that is, statement (4) is the true one. Once again statements (3) and (4) do not contradict each other, and here we learn from statement (2) that Dawn is the vile culprit.

## Section 2.2

1. (a)

(i)

$p$	$q$	$r$	$q \wedge r$	$p \rightarrow (q \wedge r)$	$p \rightarrow q$	$p \rightarrow r$	$(p \rightarrow q) \wedge (p \rightarrow r)$
0	0	0	0	1	1	1	1
0	0	1	0	1	1	1	1
0	1	0	0	1	1	1	1
0	1	1	1	1	1	1	1
1	0	0	0	0	0	0	0
1	0	1	0	0	0	1	0
1	1	0	0	0	1	0	0
1	1	1	1	1	1	1	1

(ii)

$p$	$q$	$r$	$p \vee q$	$(p \vee q) \rightarrow r$	$p \rightarrow r$	$q \rightarrow r$	$(p \rightarrow r) \wedge (q \rightarrow r)$
0	0	0	0	1	1	1	1
0	0	1	0	1	1	1	1
0	1	0	1	0	1	0	0
0	1	1	1	1	1	1	1
1	0	0	1	0	0	1	0
1	0	1	1	1	1	1	1
1	1	0	1	0	0	0	0
1	1	1	1	1	1	1	1

(iii)

$p$	$q$	$r$	$q \vee r$	$p \rightarrow (q \vee r)$	$p \rightarrow q$	$\neg r \rightarrow (p \rightarrow q)$
0	0	0	0	1	1	1
0	0	1	1	1	1	1
0	1	0	1	1	1	1
0	1	1	1	1	1	1
1	0	0	0	0	0	0
1	0	1	1	1	0	1
1	1	0	1	1	1	1
1	1	1	1	1	1	1

b)

$$\begin{aligned}
 [p \rightarrow (q \vee r)] &\iff [\neg r \rightarrow (p \rightarrow q)] \\
 &\iff [\neg r \rightarrow (\neg p \vee q)] \\
 &\iff [\neg(\neg p \vee q) \rightarrow \neg\neg r] \\
 &\iff [(\neg\neg p \wedge \neg q) \rightarrow r] \\
 &\iff [(p \wedge \neg q) \rightarrow r]
 \end{aligned}$$

From part (iii) of part (a)  
 By the 2nd Substitution Rule,  
 and  $(p \rightarrow q) \iff (\neg p \vee q)$   
 By the 1st Substitution Rule,  
 and  $(s \rightarrow t) \iff (\neg t \rightarrow \neg s)$ , for  
 primitive statements  $s, t$   
 By DeMorgan's Law, Double Negation  
 and the 2nd Substitution Rule  
 By Double Negation and the  
 2nd Substitution Rule

2.

$p$	$q$	$p \wedge q$	$p \vee (p \wedge q)$
0	0	0	0
0	1	0	0
1	0	0	1
1	1	1	1

3. a) For a primitive statement  $s$ ,  $s \vee \neg s \iff T_0$ . Replace each occurrence of  $s$  by  $p \vee (q \wedge r)$  and the result follows by the 1st Substitution Rule.

b) For primitive statements  $s, t$  we have  $(s \rightarrow t) \iff (\neg t \rightarrow \neg s)$ . Replace each occurrence of  $s$  by  $p \vee q$ , and each occurrence of  $t$  by  $r$ , and the result is a consequence of the 1st Substitution Rule.

4. (1)  $[(p \wedge q) \wedge r] \vee [(p \wedge q) \wedge \neg r] \iff (p \wedge q) \wedge (r \vee \neg r) \iff (p \wedge q) \wedge T_0 \iff p \wedge q$ .

(2)  $[(p \wedge q) \vee \neg q] \iff (p \vee \neg q) \wedge (q \vee \neg q) \iff (p \vee \neg q) \wedge T_0 \iff p \vee \neg q$ .

Therefore, the given statement simplifies to  $(p \vee \neg q) \rightarrow s$  or  $(q \rightarrow p) \rightarrow s$

5. a) Kelsey placed her studies before her interest in cheerleading, but she (still) did not get a good education.

b) Norma is not doing her mathematics homework or Karen is not practicing her piano lesson.

c) Harold did pass his C++ course and he did finish his data structures project, but he did not graduate at the end of the semester.

6. (a)  $\neg[p \wedge (q \vee r) \wedge (\neg p \vee \neg q \vee r)] \iff \neg p \vee (\neg q \wedge \neg r) \vee (p \wedge q \wedge \neg r) \iff (\neg q \wedge \neg r) \vee [\neg p \vee (p \wedge q \wedge \neg r)] \iff (\neg q \wedge \neg r) \vee [T_0 \wedge (\neg p \vee (q \wedge \neg r))] \iff (\neg q \wedge \neg r) \vee [\neg p \vee (q \wedge \neg r)] \iff \neg p \vee [(\neg q \vee q) \wedge \neg r] \iff \neg p \vee \neg r$ .

(b)  $\neg[(p \wedge q) \rightarrow r] \iff \neg[\neg(p \wedge q) \vee r] \iff (p \wedge q) \wedge \neg r$ .

(c)  $p \wedge (q \vee \neg r)$

(d)  $\neg p \wedge \neg q \wedge \neg r$

7. a)

$p$	$q$	$(\neg p \vee q) \wedge (p \wedge (p \wedge q))$	$p \wedge q$
0	0	0	0
0	1	0	0
1	0	0	0
1	1	1	1

b)  $(\neg p \wedge q) \vee (p \vee (p \vee q)) \iff p \vee q$

8. (a)  $q \rightarrow p \iff \neg q \vee p$ , so  $(q \rightarrow p)^d \iff \neg q \wedge p$ .

(b)  $p \rightarrow (q \wedge r) \iff \neg p \vee (q \wedge r)$ , so  $[p \rightarrow (q \wedge r)]^d \iff \neg p \wedge (q \vee r)$ .

(c)  $p \leftrightarrow q \iff (p \rightarrow q) \wedge (q \rightarrow p) \iff (\neg p \vee q) \wedge (\neg q \vee p)$ , so  $(p \leftrightarrow q)^d \iff (\neg p \wedge q) \vee (\neg q \wedge p)$ .

(d)  $p \underline{\vee} q \iff (p \wedge \neg q) \vee (\neg p \wedge q)$ , so  $(p \underline{\vee} q)^d \iff (p \vee \neg q) \wedge (\neg p \vee q)$ .

9. (a) If  $0 + 0 = 0$ , then  $2 + 2 = 1$ .

Let  $p : 0 + 0 = 0$ ,  $q : 1 + 1 = 1$ .

(The implication:  $p \rightarrow q$ ) - If  $0 + 0 = 0$ , then  $1 + 1 = 1$ . - False.

(The Converse of  $p \rightarrow q$ :  $q \rightarrow p$ ) - If  $1 + 1 = 1$ , then  $0 + 0 = 0$ . - True

(The Inverse of  $p \rightarrow q$ :  $\neg p \rightarrow \neg q$ ) - If  $0 + 0 \neq 0$ , then  $1 + 1 \neq 1$ . - True

(The Contrapositive of  $p \rightarrow q$ :  $\neg q \rightarrow \neg p$ ) - If  $1 + 1 \neq 1$ , then  $0 + 0 \neq 0$ . - False

(b) If  $-1 < 3$  and  $3 + 7 = 10$ , then  $\sin(\frac{3\pi}{2}) = -1$ . (TRUE)

Converse: If  $\sin(\frac{3\pi}{2}) = -1$ , then  $-1 < 3$  and  $3 + 7 = 10$ . (TRUE)

Inverse: If  $-1 \geq 3$  or  $3 + 7 \neq 10$ , then  $\sin(\frac{3\pi}{2}) \neq -1$ . (TRUE)

Contrapositive: If  $\sin(\frac{3\pi}{2}) \neq -1$ , then  $-1 \geq 3$  or  $3 + 7 \neq 10$ .

10. (a) True

(b) True

(c) True

11. a)  $(q \rightarrow r) \vee \neg p$

b)  $(\neg q \vee r) \vee \neg p$

12.

$p$	$q$	$p \underline{\vee} q$	$p \wedge \neg q$	$\neg p \wedge q$	$(p \wedge \neg q) \vee (\neg p \wedge q)$	$\neg(p \leftrightarrow q)$
0	0	0	0	0	0	0
0	1	1	0	1	1	1
1	0	1	1	0	1	1
1	1	0	0	0	0	0

13.

$p$	$q$	$r$	$[(p \leftrightarrow q) \wedge (q \leftrightarrow r) \wedge (r \leftrightarrow p)]$	$[(p \rightarrow q) \wedge (q \rightarrow r) \wedge (r \rightarrow p)]$
0	0	0	1	1
0	0	1	0	0
0	1	0	0	0
0	1	1	0	0
1	0	0	0	0
1	0	1	0	0
1	1	0	0	0
1	1	1	1	1

14.

(a)

$p$	$q$	$p \wedge q$	$q \rightarrow (p \wedge q)$	$p \rightarrow [q \rightarrow (p \wedge q)]$
0	0	0	1	1
0	1	0	0	1
1	0	0	1	1
1	1	1	1	1

(b) Replace each occurrence of  $p$  by  $p \vee q$ . Then we have the tautology  $(p \vee q) \rightarrow [q \rightarrow [(p \vee q) \wedge q]]$  by the first substitution rule. Since  $(p \vee q) \wedge q \iff q$ , by the absorption laws, it follows that  $(p \vee q) \rightarrow [q \rightarrow q] \iff T_0$ .

(c)

$p$	$q$	$p \vee q$	$p \wedge q$	$q \rightarrow (p \wedge q)$	$(p \vee q) \rightarrow [q \rightarrow (p \wedge q)]$
0	0	0	0	1	1
0	1	1	0	0	0
1	0	1	0	1	1
1	1	1	1	1	1

So the given statement is not a tautology. If we try to apply the second substitution rule to the result in part (a) we would replace the first occurrence of  $p$  by  $p \vee q$ . But this does not result in a tautology because it is not a valid application of this substitution rule – for  $p$  is not logically equivalent to  $p \vee q$ .

15. (a)  $\neg p \iff (p \uparrow p)$   
 (b)  $p \vee q \iff \neg(\neg p \wedge \neg q) \iff (\neg p \uparrow \neg q) \iff (p \uparrow p) \uparrow (q \uparrow q)$   
 (c)  $p \wedge q \iff \neg\neg(p \wedge q) \iff \neg(p \uparrow q) \iff (p \uparrow q) \uparrow (p \uparrow q)$   
 (d)  $p \rightarrow q \iff \neg p \vee q \iff \neg(p \wedge \neg q) \iff (p \uparrow \neg q) \iff p \uparrow (q \uparrow q)$   
 (e)  $p \leftrightarrow q \iff (p \rightarrow q) \wedge (q \rightarrow p) \iff t \wedge u \iff (t \uparrow u) \uparrow (t \uparrow u)$ , where  $t$  stands for  $p \uparrow (q \uparrow q)$  and  $u$  for  $q \uparrow (p \uparrow p)$ .

16. (a)  $\neg p \iff (p \downarrow p)$   
 (b)  $p \vee q \iff \neg\neg(p \vee q) \iff \neg(p \downarrow q) \iff (p \downarrow q) \downarrow (p \downarrow q)$   
 (c)  $p \wedge q \iff \neg\neg p \wedge \neg\neg q \iff (\neg p \downarrow \neg q) \iff (p \downarrow p) \downarrow (q \downarrow q)$   
 (d)  $p \rightarrow q \iff \neg p \vee q \iff (\neg p \downarrow q) \downarrow (\neg p \downarrow q) \iff [(p \downarrow p) \downarrow q] \downarrow [(p \downarrow p) \downarrow q]$   
 (e)  $p \leftrightarrow q \iff (r \downarrow r) \downarrow (s \downarrow s)$  where  $r$  stands for  $[(p \downarrow p) \downarrow q] \downarrow [(p \downarrow p) \downarrow q]$  and  $s$  for  $[(q \downarrow q) \downarrow p] \downarrow [(q \downarrow q) \downarrow p]$

17.

$p$	$q$	$\neg(p \downarrow q)$	$(\neg p \uparrow \neg q)$	$\neg(p \uparrow q)$	$(\neg p \downarrow \neg q)$
0	0	0	0	0	0
0	1	1	1	0	0
1	0	1	1	0	0
1	1	1	1	1	1

18.

$$\begin{aligned} \text{(a)} \quad & [(p \vee q) \wedge (p \vee \neg q)] \vee q \\ \Leftrightarrow & [p \vee (q \wedge \neg q)] \vee q \\ \Leftrightarrow & (p \vee F_0) \vee q \\ \Leftrightarrow & p \vee q \end{aligned}$$

**Reasons**  
Distributive Law of  $\vee$  over  $\wedge$   
 $q \wedge \neg q \Leftrightarrow F_0$  (Inverse Law)  
 $p \vee F_0 \Leftrightarrow p$  (Identity Law)

$$\begin{aligned} \text{(b)} \quad & (p \rightarrow q) \wedge [\neg q \wedge (r \vee \neg q)] \\ \Leftrightarrow & (p \rightarrow q) \wedge \neg q \\ \\ \Leftrightarrow & (\neg p \vee q) \wedge \neg q \\ \Leftrightarrow & \neg q \wedge (\neg p \vee q) \\ \Leftrightarrow & (\neg q \wedge \neg p) \vee (\neg q \wedge q) \\ \Leftrightarrow & (\neg q \wedge \neg p) \vee F_0 \\ \Leftrightarrow & \neg q \wedge \neg p \\ \Leftrightarrow & \neg(q \vee p) \end{aligned}$$

**Reasons**  
Absorption Law (and the Commutative Law of  $\vee$ )  
 $p \rightarrow q \Leftrightarrow \neg p \vee q$   
Commutative Law of  $\wedge$   
Distributive Law of  $\wedge$  over  $\vee$   
Inverse Law  
Identity Law  
DeMorgan's Laws

19.

$$\begin{aligned} \text{(a)} \quad & p \vee [p \wedge (p \vee q)] \\ \Leftrightarrow & p \vee p \\ \Leftrightarrow & p \end{aligned}$$

**Reasons**  
Absorption Law  
Idempotent Law of  $\vee$

$$\begin{aligned} \text{(b)} \quad & p \vee q \vee (\neg p \wedge \neg q \wedge r) \\ \Leftrightarrow & (p \vee q) \vee [\neg(p \vee q) \wedge r] \\ \Leftrightarrow & [(p \vee q) \vee \neg(p \vee q)] \wedge (p \vee q \vee r) \\ \Leftrightarrow & T_0 \wedge (p \vee q \vee r) \\ \Leftrightarrow & p \vee q \vee r \end{aligned}$$

**Reasons**  
DeMorgan's Laws  
Distributive Law of  $\vee$  over  $\wedge$   
Inverse Law  
Identity Law

$$\begin{aligned} \text{(c)} \quad & [(\neg p \vee \neg q) \rightarrow (p \wedge q \wedge r)] \\ \Leftrightarrow & \neg(\neg p \vee \neg q) \vee (p \wedge q \wedge r) \\ \Leftrightarrow & (\neg\neg p \wedge \neg\neg q) \vee (p \wedge q \wedge r) \\ \Leftrightarrow & (p \wedge q) \vee (p \wedge q \wedge r) \\ \Leftrightarrow & p \wedge q \end{aligned}$$

**Reasons**  
 $s \rightarrow t \Leftrightarrow \neg s \vee t$   
DeMorgan's Laws  
Law of Double Negation  
Absorption Law

$$\text{20. (a)} \quad [p \wedge (\neg r \vee q \vee \neg q)] \vee [(r \vee t \vee \neg r) \wedge \neg q] \Leftrightarrow [p \wedge (\neg r \vee T_0)] \vee [(T_0 \vee t) \wedge \neg q] \Leftrightarrow (p \wedge T_0) \vee (T_0 \wedge \neg q) \Leftrightarrow p \vee \neg q$$

$$\text{(b)} \quad [p \vee (p \wedge q) \vee (p \wedge q \wedge r)] \wedge [(p \wedge r \wedge t) \vee t] \Leftrightarrow p \wedge t \text{ by the Absorption Law.}$$

### Section 2.3

1. (a)

$p$	$q$	$r$	$p \rightarrow q$	$(p \vee q)$	$(p \vee q) \rightarrow r$
0	0	0	1	0	1
0	0	1	1	0	1
0	1	0	1	1	0
0	1	1	1	1	1
1	0	0	0	1	0
1	0	1	0	1	1
1	1	0	1	1	0
1	1	1	1	1	1

The validity of the argument follows from the results in the last row. (The first seven rows may be ignored.)

(b)

$p$	$q$	$r$	$(p \wedge q) \rightarrow r$	$\neg q$	$p \rightarrow \neg r$	$\neg p \vee \neg q$
0	0	0	1	1	1	1
0	0	1	1	1	1	1
0	1	0	1	0	1	1
0	1	1	1	0	1	1
1	0	0	1	1	1	1
1	0	1	1	1	0	1
1	1	0	0	0	1	0
1	1	1	1	0	0	0

The validity of the argument follows from the results in rows 1, 2, and 5 of the table. The results in the other five rows may be ignored.

(c)

$p$	$q$	$r$	$q \vee r$	$p \vee (q \vee r)$	$[p \vee (q \vee r)] \wedge \neg q$	$p \vee r$
0	0	0	0	0	0	0
0	0	1	1	1	1	1
0	1	0	1	1	0	0
0	1	1	1	1	0	1
1	0	0	0	1	1	1
1	0	1	1	1	1	1
1	1	0	1	1	0	1
1	1	1	1	1	0	1

Consider the last two columns of this truth table. Here we find that whenever the truth value of  $[p \vee (q \vee r)] \wedge \neg q$  is 1 then the truth value of  $p \vee r$  is also 1. Consequently,

$$[[p \vee (q \vee r)] \wedge \neg q] \Rightarrow p \vee r.$$

(The rows of the table that are crucial for assessing the validity of the argument are rows 2, 5, and 6. Rows 1, 3, 4, 7, and 8 may be ignored.)

2. (a)

$p$	$q$	$r$	$p \rightarrow q$	$q \rightarrow r$	$p \rightarrow r$	$[(p \rightarrow q) \wedge (q \rightarrow r)] \rightarrow (p \rightarrow r)$
0	0	0	1	1	1	1
0	0	1	1	1	1	1
0	1	0	1	0	1	1
0	1	1	1	1	1	1
1	0	0	0	1	0	1
1	0	1	0	1	1	1
1	1	0	1	0	0	1
1	1	1	1	1	1	1

(b)

$p$	$q$	$p \rightarrow q$	$(p \rightarrow q) \wedge \neg q$	$[(p \rightarrow q) \wedge \neg q] \rightarrow \neg p$
0	0	1	1	1
0	1	1	0	1
1	0	0	0	1
1	1	1	0	1

(c)

$p$	$q$	$\neg p$	$p \vee q$	$(p \vee q) \wedge \neg p$	$[(p \vee q) \wedge \neg p] \rightarrow q$
0	0	1	0	0	1
0	1	1	1	1	1
1	0	0	1	0	1
1	1	0	1	0	1

(d)

$p$	$q$	$r$	$p \rightarrow r$	$q \rightarrow r$	$\overbrace{(p \vee q) \rightarrow r}^s$	$[(p \rightarrow r) \wedge (q \rightarrow r)] \rightarrow s$
0	0	0	1	1	1	1
0	0	1	1	1	1	1
0	1	0	1	0	0	1
0	1	1	1	1	1	1
1	0	0	0	1	0	1
1	0	1	1	1	1	1
1	1	0	0	0	0	1
1	1	1	1	1	1	1

3. (a) If  $p$  has the truth value 0, then so does  $p \wedge q$ .  
 (b) When  $p \vee q$  has the truth value 0, then the truth value of  $p$  (and that of  $q$ ) is 0.  
 (c) If  $q$  has truth value 0, then the truth value of  $[(p \vee q) \wedge \neg p]$  is 0, regardless of the truth value of  $p$ .  
 (d) The statement  $q \vee s$  has truth value 0 only when each of  $q, s$  has truth value 0. Then

$(p \rightarrow q)$  has truth value 1 when  $p$  has truth value 0;  $(r \rightarrow s)$  has truth value 1 when  $r$  has truth value 0. But then  $(p \vee r)$  must have truth value 0, not 1.

(e) For  $(\neg p \vee \neg r)$  the truth value is 0 when both  $p, r$  have truth value 1. This then forces  $q, s$  to have truth value 1, in order for  $(p \rightarrow q), (r \rightarrow s)$  to have truth value 1. However, this results in truth value 0 for  $(\neg q \vee \neg s)$ .

4. (a) Janice's daughter Angela will check Janice's spark plugs. (Modus Ponens)
- (b) Brady did not solve the first problem correctly. (Modus Tollens)
- (c) This is a **repeat-until** loop. (Modus Ponens)
- (d) Tim watched television in the evening. (Modus Tollens)

5. (a) Rule of Conjunctive Simplification
- (b) Invalid – attempt to argue by the converse
- (c) Modus Tollens
- (d) Rule of Disjunctive Syllogism
- (e) Invalid – attempt to argue by the inverse

6. (a)

Steps	Reasons
(1) $q \wedge r$	Premise
(2) $q$	Step (1) and the Rule of Conjunctive Simplification
(3) $\therefore q \vee r$	Step (2) and the Rule of Disjunctive Amplification

Consequently,  $(q \wedge r) \rightarrow (q \vee r)$  is a tautology, or  $q \wedge r \Rightarrow q \vee r$ .

(b) Consider the truth value assignments  $p : 0, q : 1,$  and  $r : 0$ . For these assignments  $[p \wedge (q \wedge r)] \vee \neg[p \vee (q \wedge r)]$  has truth value 1, while  $[p \wedge (q \vee r)] \vee \neg[p \vee (q \vee r)]$  has truth value 0. Therefore,  $P \rightarrow P_1$  is *not* a tautology, or  $P \not\Rightarrow P_1$ .

7.

- (1) & (2) Premise
- (3) Steps (1), (2) and the Rule of Detachment
- (4) Premise
- (5) Step (4) and  $(r \rightarrow \neg q) \iff (\neg\neg q \rightarrow \neg r) \iff (q \rightarrow \neg r)$
- (6) Steps (3), (5) and the Rule of Detachment
- (7) Premise
- (8) Steps (6), (7) and the Rule of Disjunctive Syllogism
- (9) Step (8) and the Rule of Disjunctive Amplification

8.

- (1) Premise
- (2) Step (1) and the Rule of Conjunctive Simplification
- (3) Premise
- (4) Steps (2), (3) and the Rule of Detachment

- (5) Step (1) and the Rule of Conjunctive Simplification
- (6) Steps (4), (5) and the Rule of Conjunction
- (7) Premise
- (8) Step (7) and  $[r \rightarrow (s \vee t)] \iff [\neg(s \vee t) \rightarrow \neg r]$
- (9) Step (8) and DeMorgan's Laws
- (10) Steps (6), (9) and the Rule of Detachment
- (11) Premise
- (12) Step (11) and  $[(\neg p \vee q) \rightarrow r] \iff [\neg r \rightarrow \neg(\neg p \vee q)]$
- (13) Step (12) and DeMorgan's Laws and the Law of Double Negation
- (14) Steps (10), (13) and the Rule of Detachment
- (15) Step (14) and the Rule of Conjunctive Simplification

9. (a)

- (1) Premise (The Negation of the Conclusion)
- (2) Step (1) and  $\neg(\neg q \rightarrow s) \iff \neg(\neg\neg q \vee s) \iff \neg(q \vee s) \iff \neg q \wedge \neg s$
- (3) Step (2) and the Rule of Conjunctive Simplification
- (4) Premise
- (5) Steps (3), (4) and the Rule of Disjunctive Syllogism
- (6) Premise
- (7) Step (2) and the Rule of Conjunctive Simplification
- (8) Steps (6), (7) and Modus Tollens
- (9) Premise
- (10) Steps (8), (9) and the Rule of Disjunctive Syllogism
- (11) Steps (5), (10) and the Rule of Conjunction
- (12) Step (11) and the Method of Proof by Contradiction

(b)

- (1)  $p \rightarrow q$  Premise
- (2)  $\neg q \rightarrow \neg p$  Step (1) and  $(p \rightarrow q) \iff (\neg q \rightarrow \neg p)$
- (3)  $p \vee r$  Premise
- (4)  $\neg p \rightarrow r$  Step (3) and  $(p \vee r) \iff (\neg p \rightarrow r)$
- (5)  $\neg q \rightarrow r$  Steps (2), (4) and the Law of the Syllogism
- (6)  $\neg r \vee s$  Premise
- (7)  $r \rightarrow s$  Step (6) and  $(\neg r \vee s) \iff (r \rightarrow s)$
- (8)  $\neg q \rightarrow s$  Steps (5), (7) and the Law of the Syllogism

(c)

- (1)  $\neg p \leftrightarrow q$  Premise
- (2)  $(\neg p \rightarrow q) \wedge (q \rightarrow \neg p)$  Step (1) and  $(\neg p \leftrightarrow q) \iff [(\neg p \rightarrow q) \wedge (q \rightarrow \neg p)]$

- |     |                        |   |
|-----|------------------------|---|
| (3) | $\neg p \rightarrow q$ | Step (2) and the Rule of Conjunctive Simplification |
| (4) | $q \rightarrow r$      | Premise   |
| (5) | $\neg p \rightarrow r$ | Steps (3), (4) and the Law of the Syllogism         |
| (6) | $\neg r$               | Premise   |
| (7) | $\therefore p$         | Steps (5), (6) and Modus Tollens.                   |

10. (a)

- |     |                                  |   |
|-----|----------------------------------|---|
| (1) | $p \wedge \neg q$                | Premise   |
| (2) | $p$                              | Step (1) and the Rule of Conjunctive Simplification |
| (3) | $r$                              | Premise   |
| (4) | $p \wedge r$                     | Steps (2), (3) and the Rule of Conjunction          |
| (5) | $\therefore (p \wedge r) \vee q$ | Step (4) and the Rule of Disjunctive Amplification  |

(b)

- |     |                      |   |
|-----|----------------------|---|
| (1) | $p, p \rightarrow q$ | Premises  |
| (2) | $q$                  | Step (1) and the Rule of Detachment                 |
| (3) | $\neg q \vee r$      | Premise   |
| (4) | $q \rightarrow r$    | Step (3) and $\neg q \vee r \iff (q \rightarrow r)$ |
| (5) | $\therefore r$       | Steps (2), (4) and the Rule of Detachment           |

(c)

- |     |                             |  |
|-----|-----------------------------|--|
| (1) | $p \rightarrow q, \neg q$   | Premises                                   |
| (2) | $\neg p$                    | Step (1) and Modus Tollens                 |
| (3) | $\neg r$                    | Premise                                    |
| (4) | $\neg p \wedge \neg r$      | Steps (2), (3) and the Rule of Conjunction |
| (5) | $\therefore \neg(p \vee r)$ | Step (4) and DeMorgan's Laws               |

(d)

- |     |                           |                                     |
|-----|---------------------------|-------------------------------------|
| (1) | $r, r \rightarrow \neg q$ | Premises                            |
| (2) | $\neg q$                  | Step (1) and the Rule of Detachment |
| (3) | $p \rightarrow q$         | Premise                             |
| (4) | $\therefore \neg p$       | Steps (2), (3) and Modus Tollens    |

(e)		
(1)	$p$	Premise
(2)	$\neg q \rightarrow \neg p$	Premise
(3)	$p \rightarrow q$	Step (2) and $(p \rightarrow q) \iff (\neg q \rightarrow \neg p)$
(4)	$q$	Steps (1), (3) and the Rule of Detachment
(5)	$p \wedge q$	Steps (1), (4) and the Rule of Conjunction
(6)	$p \rightarrow (q \rightarrow r)$	Premise
(7)	$(p \wedge q) \rightarrow r$	Step (6), and $[p \rightarrow (q \rightarrow r)] \iff [(p \wedge q) \rightarrow r]$
(8)	$\therefore r$	Steps (5), (7) and the Rule of Detachment

(f)		
(1)	$p \wedge q$	Premise
(2)	$p$	Step (1) and the Rule of Conjunctive Simplification
(3)	$p \rightarrow (r \wedge q)$	Premise
(4)	$r \wedge q$	Steps (2), (3) and the Rule of Detachment
(5)	$r$	Step (4) and the Rule of Conjunctive Simplification
(6)	$r \rightarrow (s \vee t)$	Premise
(7)	$s \vee t$	Steps (5), (6) and the Rule of Detachment
(8)	$\neg s$	Premise
(9)	$\therefore t$	Steps (7), (8) and the Rule of Disjunctive Syllogism

(g)		
(1)	$\neg s, p \vee s$	Premises
(2)	$p$	Step (1) and the Rule of Disjunctive Syllogism
(3)	$p \rightarrow (q \rightarrow r)$	Premise
(4)	$q \rightarrow r$	Steps (2), (3) and the Rule of Detachment
(5)	$t \rightarrow q$	Premise
(6)	$t \rightarrow r$	Steps (4), (5) and the Law of the Syllogism
(7)	$\therefore \neg r \rightarrow \neg t$	Step (6) and $(t \rightarrow r) \iff (\neg r \rightarrow \neg t)$

(h)		
(1)	$\neg p \vee r$	Premise
(2)	$p \rightarrow r$	Step (1) and $(p \rightarrow r) \iff (\neg p \vee r)$
(3)	$\neg r$	Premise
(4)	$\neg p$	Steps (2), (3) and Modus Tollens
(5)	$p \vee q$	Premise
(6)	$\neg p \rightarrow q$	Step (5) and $(p \vee q) \iff (\neg \neg p \vee q) \iff (\neg p \rightarrow q)$
(7)	$\therefore q$	Steps (4), (6) and Modus Ponens

11. (a)  $p:1 \quad q:0 \quad r:1$   
 (b)  $p:0 \quad q:0 \quad r:0$  or  $1$   
        $p:0 \quad q:1 \quad r:1$   
 (c)  $p, q, r:1 \quad s:0$   
 (d)  $p, q, r:1 \quad s:0$

12. a)  $p$ : Rochelle gets the supervisor's position.  
        $q$ : Rochelle works hard.  
        $r$ : Rochelle gets a raise.  
        $s$ : Rochelle buys a new car.

$$\begin{array}{l} (p \wedge q) \rightarrow r \\ r \rightarrow s \\ \hline \neg s \\ \therefore \neg p \vee \neg q \end{array}$$

- |     |                                 |   |
|-----|---------------------------------|---|
| (1) | $\neg s$                        | Premise   |
| (2) | $r \rightarrow s$               | Premise   |
| (3) | $\neg r$                        | Steps (1), (2) and Modus Tollens                          |
| (4) | $(p \wedge q) \rightarrow r$    | Premise   |
| (5) | $\neg(p \wedge q)$              | Steps (3), (4) and Modus Tollens                          |
| (6) | $\therefore \neg p \vee \neg q$ | Step (5) and $\neg(p \wedge q) \iff \neg p \vee \neg q$ . |

- b)  $p$ : Dominic goes to the racetrack.  
        $q$ : Helen gets mad.  
        $r$ : Ralph plays cards all night.  
        $s$ : Carmela gets mad.  
        $t$ : Veronica is notified.

$$\begin{array}{l} p \rightarrow q \\ r \rightarrow s \\ (q \vee s) \rightarrow t \\ \hline \neg t \\ \therefore \neg p \wedge \neg r \end{array}$$

- |     |                            |   |
|-----|----------------------------|---|
| (1) | $\neg t$                   | Premise   |
| (2) | $(q \vee s) \rightarrow t$ | Premise   |
| (3) | $\neg(q \vee s)$           | Steps (1), (2) and Modus Tollens                        |
| (4) | $\neg q \wedge \neg s$     | Step (3) and $\neg(q \vee s) \iff \neg q \wedge \neg s$ |
| (5) | $\neg q$                   | Step (4) and the Rule of Conjunctive Simplification     |
| (6) | $p \rightarrow q$          | Premise   |
| (7) | $\neg p$                   | Steps (5), (6) and Modus Tollens                        |
| (8) | $\neg s$                   | Step (4) and the Rule of Conjunctive Simplification     |

- (9)  $r \rightarrow s$  Premise  
 (10)  $\neg r$  Steps (8), (9) and Modus Tollens  
 (11)  $\therefore \neg p \wedge \neg r$  Steps (7), (10) and the Rule of Conjunction

- c)  $p$ : There is a chance of rain.  
 $q$ : Lois' red head scarf is missing.  
 $r$ : Lois does not mow her lawn.  
 $s$ : The temperature is over 80° F.

$$\begin{array}{l} (p \vee q) \rightarrow r \\ s \rightarrow \neg p \\ s \wedge \neg q \\ \hline \therefore \neg r \end{array}$$

The following truth value assignments provide a counterexample to the validity of this argument:

$$p : 0; q : 0; r : 1; s : 1$$

13. (a)

			$t$				
$p$	$q$	$r$	$p \vee q$	$\neg p \vee r$	$(p \vee q) \wedge (\neg p \vee r)$	$q \vee r$	$t \rightarrow (q \vee r)$
0	0	0	0	1	0	0	1
0	0	1	0	1	0	1	1
0	1	0	1	1	1	1	1
0	1	1	1	1	1	1	1
1	0	0	1	0	0	0	1
1	0	1	1	1	1	1	1
1	1	0	1	0	0	1	1
1	1	1	1	1	1	1	1

From the last column of the truth table it follows that  $[(p \vee q) \wedge (\neg p \vee r)] \rightarrow (q \vee r)$  is a tautology.

Alternately we can try to see if there are truth values that can be assigned to  $p, q,$  and  $r$  so that  $(q \vee r)$  has truth value 0 while  $(p \vee q), (\neg p \vee r)$  both have truth value 1.

For  $(q \vee r)$  to have truth value 0, it follows that  $q : 0$  and  $r : 0$ . Consequently, for  $(p \vee q)$  to have truth value 1, we have  $p : 1$  since  $q : 0$ . Likewise, with  $r : 0$  it follows that  $\neg p : 1$  if  $(\neg p \vee r)$  has truth value 1. But we cannot have  $p : 1$  and  $\neg p : 1$ . So whenever  $(p \vee q), (\neg p \vee r)$  have truth value 1, we have  $(q \vee r)$  with truth value 1 and it follows that  $[(p \vee q) \wedge (\neg p \vee r)] \rightarrow (q \vee r)$  is a tautology.

Finally we can also argue as follows:

Steps	Reasons
1. $p \vee q$	1. Premise
2. $q \vee p$	2. Step (1) and the Commutative Law of $\vee$
3. $\neg(\neg q) \vee p$	3. Step (2) and the Law of Double Negation
4. $\neg q \rightarrow p$	4. Step (3), $\neg q \rightarrow p \Leftrightarrow \neg(\neg q) \vee p$
5. $\neg p \vee r$	5. Premise
6. $p \rightarrow r$	6. Step (5), $p \rightarrow r \Leftrightarrow \neg p \vee r$
7. $\neg q \rightarrow r$	7. Steps (4), (6), and the Law of the Syllogism
8. $\therefore q \vee r$	8. Step (7), $\neg q \rightarrow r \Leftrightarrow q \vee r$

(b)

(i) Steps	Reasons
1. $p \vee (q \vee r)$	1. Premise
2. $(p \vee q) \wedge (p \vee r)$	2. Step (1) and the Distribution Law of $\vee$ over $\wedge$
3. $p \vee r$	3. Step (2) and the Rule of Conjunctive Simplification
4. $p \rightarrow s$	4. Premise
5. $\neg p \vee s$	5. Step (4), $p \rightarrow s \Leftrightarrow \neg p \vee s$
6. $\therefore r \vee s$	6. Steps (3), (5), the Rule of Conjunction, and Resolution

(ii) Steps	Reasons
1. $p \leftrightarrow q$	1. Premise
2. $(p \rightarrow q) \wedge (q \rightarrow p)$	2. $(p \leftrightarrow q) \Leftrightarrow [(p \rightarrow q) \wedge (q \rightarrow p)]$
3. $p \rightarrow q$	3. Step (2) and the rule of Conjunctive Simplification
4. $\neg p \vee q$	4. Step (3), $p \rightarrow q \Leftrightarrow \neg p \vee q$
5. $p$	5. Premise
6. $p \vee q$	7. Step (5) and the Rule of Disjunctive Amplification
7. $[(p \vee q) \wedge (\neg p \vee q)]$	7. Steps (6), (4), and the Rule of Conjunction
8. $q \vee q$	8. Step (7) and Resolution
9. $\therefore q$	9. Step (8) and the Idempotent Law of $\vee$ .

(iii) Steps	Reasons
1. $p \vee q$	1. Premise
2. $p \rightarrow r$	2. Premise
3. $\neg p \vee r$	3. Step (2), $p \rightarrow r \Leftrightarrow \neg p \vee r$
4. $[(p \vee q) \wedge (\neg p \vee r)]$	4. Steps (1), (3), and the Rule of Conjunction
5. $q \vee r$	5. Step (4) and Resolution
6. $r \rightarrow s$	6. Premise
7. $\neg r \vee s$	7. Step (6), $r \rightarrow s \Leftrightarrow \neg r \vee s$
8. $[(r \vee q) \wedge (\neg r \vee s)]$	8. Steps (5), (7), the Commutative Law of $\vee$ , and the Rule of Conjunction
9. $\therefore q \vee s$	9. Step (8) and Resolution

(iv) Steps	Reasons
1. $\neg p \vee q \vee r$	1. Premise
2. $q \vee (\neg p \vee r)$	2. Step (1) and the Commutative and Associative Laws of $\vee$
3. $\neg q$	3. Premise
4. $\neg q \vee (\neg p \vee r)$	4. Step (3) and the Rule of Disjunctive Amplification
5. $[[q \vee (\neg \vee r)] \wedge [\neg q \vee (\neg p \vee r)]]$	5. Steps (2), (4), and the Rule of Conjunction
6. $(\neg p \vee r)$	6. Step (5), Resolution, and the Idempotent Law of $\wedge$
7. $\neg r$	7. Premise
8. $\neg r \vee \neg p$	8. Step (7) and the Rule of Disjunctive Amplification
9. $[(r \vee \neg p) \wedge (\neg r \vee \neg p)]$	9. Steps (6), (8), the Commutative Law of $\vee$ , and the Rule of Conjunction
10. $\therefore \neg p$	10. Step (9), Resolution, and the Idempotent Law of $\vee$

(v) Steps	Reasons
1. $\neg p \vee s$	1. Premise
2. $p \vee q \vee t$	2. Premise
3. $p \vee (q \vee t)$	3. Step (2) and the Associative Law of $\vee$
4. $[[p \vee (q \vee t)] \wedge (\neg p \vee s)]$	4. Steps (3), (1), and the Rule of Conjunction
5. $(q \vee t) \vee s$	5. Step (4) and Resolution (and the First Substitution Rule)
6. $q \vee (t \vee s)$	6. Step (5) and the Associative Law of $\vee$
7. $\neg q \vee r$	7. Premise
8. $[[q \vee (t \vee s)] \wedge (\neg q \vee r)]$	8. Steps (6), (7), and the Rule of Conjunction
9. $(t \vee s) \vee r$	9. Step (8) and Resolution (and the First Substitution Rule)
10. $t \vee (s \vee r)$	10. Step (9) and the Associative Law of $\vee$
11. $\neg t \vee (s \wedge r)$	11. Premise
12. $(\neg t \vee s) \wedge (\neg t \vee r)$	12. Step (11) and the Distributive Law of $\vee$ over $\wedge$
13. $\neg t \vee s$	13. Step (12) and the Rule of Conjunctive Simplification
14. $[[t \vee (s \vee r)] \wedge (\neg t \vee s)]$	14. Steps (10), (13), and the Rule of Conjunction
15. $(s \vee r) \vee s$	15. Step (14) and Resolution (and the First Substitution Rule)
16. $\therefore r \vee s$	16. Step (15) and the Commutative, Associative, and Idempotent Laws of $\vee$

(c) Consider the following assignments.

$p$ : Jonathan has his driver's license.

$q$ : Jonathan's new car is out of gas.

$r$ : Jonathan likes to drive his new car.

Then the given argument can be written in symbolic form as

$$\begin{array}{l}
 \neg p \vee q \\
 p \vee \neg r \\
 \hline
 \neg q \vee \neg r \\
 \therefore \neg r
 \end{array}$$

Steps	Reasons
1. $\neg p \vee q$	1. Premise
2. $p \vee \neg r$	2. Premise
3. $(p \vee \neg r) \wedge (\neg p \vee q)$	3. Steps (2), (1), and the Rule of Conjunction
4. $\neg r \vee q$	4. Step (3) and Resolution
5. $q \vee \neg r$	5. Step (4) and the Commutative Law of $\vee$
6. $\neg q \vee \neg r$	6. Premise
7. $(q \vee \neg r) \wedge (\neg q \vee \neg r)$	7. Steps (5), (6), and the Rule of Conjunction
8. $\neg r \vee \neg r$	8. Step (7) and Resolution
9. $\therefore \neg r$	9. Step (8) and Idempotent Law of $\vee$

## Section 2.4

1.
 

(a) False	(b) False	(c) False
(d) True	(e) False	(f) False
  
2. (a) (i) True                                      (ii) True                                      (iii) True                                      (iv) True  
 (b) The only substitution for  $x$  that makes the open statement  $[p(x) \wedge q(x)] \wedge r(x)$  into a true statement is  $x = 2$ .
  
3. Statements (a), (c), and (e) are true, while statements (b), (d), and (f) are false.
  
4. (a) Every polygon is a quadrilateral or a triangle (but not both). (True — for this universe.)  
 (b) Every isosceles triangle is equilateral. (False)  
 (c) There exists a triangle with an interior angle that exceeds  $180^\circ$ . (False)  
 (d) A triangle has all of its interior angles equal if and only if it is an equilateral triangle. (True)  
 (e) There exists a quadrilateral that is not a rectangle. (True)  
 (f) There exists a rectangle that is not a square. (True)  
 (g) If all the sides of a polygon are equal, then the polygon is an equilateral triangle. (False)  
 (h) No triangle has an interior angle that exceeds  $180^\circ$ . (True)  
 (i) A polygon (of three or four sides) is a square if and only if all of its interior angles are equal and all of its sides are equal. (False)  
 (j) A triangle has all interior angles equal if and only if all of its sides are equal. (True)



- (c)  $\exists m, n A[m, n] > 60$   
 (d)  $\forall m [(1 \leq n < 19) \rightarrow (A[m, n] < A[m, n + 1])]$   
 (e)  $\forall n [(1 \leq m < 9) \rightarrow (A[m, n] < A[m + 1, n])]$   
 (f)  $\forall 1 \leq m, i \leq 3 \forall 1 \leq n, j \leq 20 [((m, n) \neq (i, j)) \rightarrow (A[m, n] \neq A[i, j])]$
11. (a) In this case the variable  $x$  is free while the variables  $y, z$  are bound.  
 (b) Here the variables  $x, y$  are bound; the variable  $z$  is free.
12. (a)  
 (i) False                      (ii) True                      (iii) True  
 (iv) False, if  $x = 0$     (v) False, if  $x = 0$     (vi) True  
 (vii) False — If  $y = 0$  then  $x \neq 0$ ; if  $y \neq 0$ , let  $x = 2y$ .  
 (viii) False — Let  $x = 2$  and  $y = -2$ , for example.
- (b) Statements (iv), (v), and (viii) are now true — because of the change in universe.
- (c) (i) True                      (ii) True                      (iii) True  
 (iv) False — For any  $y$  consider  $x = 2y$ .
13. (a)  $p(2, 3) \wedge p(3, 3) \wedge p(5, 3)$   
 (b)  $[p(2, 2) \vee p(2, 3) \vee p(2, 5)] \vee [p(3, 2) \vee p(3, 3) \vee p(3, 5)] \vee [p(5, 2) \vee p(5, 3) \vee p(5, 5)]$   
 (c)  $[p(2, 2) \vee p(3, 2) \vee p(5, 2)] \wedge [p(2, 3) \vee p(3, 3) \vee p(5, 3)] \wedge [p(2, 5) \vee p(3, 5) \vee p(5, 5)]$
14. Statements (a), (b), (e), and (f) are logically equivalent and each may be expressed as  $\forall n[q(n) \rightarrow p(n)]$ . Statements (c), (g) are logically equivalent and each may be expressed as  $\forall n[p(n) \rightarrow q(n)]$ . Statement (d) is not logically equivalent to any of the other six statements.
15. a) The proposed negation is correct and is a true statement.  
 b) The proposed negation is wrong. A correct version of the negation is: For all rational numbers  $x, y$ , the sum  $x + y$  is rational. This correct version of the negation is a true statement.  
 c) The proposed negation is correct — but false. The (original) statement is true.  
 d) The proposed negation is wrong. A correct version of the negation is: For all integers  $x, y$ , if  $x, y$  are both odd, then  $xy$  is even.  
     The (original) statement is true.
16. (a) Some student in Professor Lenhart's C++ class is not majoring in either computer science or mathematics.  
 (b) If a student is in Professor Lenhart's C++ class, then that student is not majoring in history.  
     or, No student majoring in history is in Professor Lenhart's C++ class.
17. a) There exists an integer  $n$  such that  $n$  is not divisible by 2 but  $n$  is even (that is, not odd).  
 b) There exist integers  $k, m, n$  such that  $k - m$  and  $m - n$  are odd, and  $k - n$  is odd.

- c) For some real number  $x$ ,  $x^2 > 16$  but  $-4 \leq x \leq 4$  (that is,  $-4 \leq x$  and  $x \leq 4$ ).  
 d) There exists a real number  $x$  such that  $|x - 3| < 7$  and either  $x \leq -4$  or  $x \geq 10$ .

18. (a)  $\forall x [\neg p(x) \wedge \neg q(x)]$   
 (b)  $\exists x [\neg p(x) \vee q(x)]$   
 (c)  $\exists x [p(x) \wedge \neg q(x)]$   
 (d)  $\forall x [(p(x) \vee q(x)) \wedge \neg r(x)]$

19. (a) Statement: For all positive integers  $m, n$ , if  $m > n$  then  $m^2 > n^2$ . (TRUE)  
 Converse: For all positive integers  $m, n$ , if  $m^2 > n^2$  then  $m > n$ . (TRUE)  
 Inverse: For all positive integers  $m, n$ , if  $m \leq n$  then  $m^2 \leq n^2$ . (TRUE)  
 Contrapositive: For all positive integers  $m, n$ , if  $m^2 \leq n^2$  then  $m \leq n$ . (TRUE)  
 (b) Statement: For all integers  $a, b$ , if  $a > b$  then  $a^2 > b^2$ . (FALSE — let  $a = 1$  and  $b = -2$ .)  
 Converse: For all integers  $a, b$ , if  $a^2 > b^2$  then  $a > b$ . (FALSE — let  $a = -5$  and  $b = 3$ .)  
 Inverse: For all integers  $a, b$ , if  $a \leq b$  then  $a^2 \leq b^2$ . (FALSE — let  $a = -5$  and  $b = 3$ .)  
 Contrapositive: For all integers  $a, b$ , if  $a^2 \leq b^2$  then  $a \leq b$ . (FALSE — let  $a = 1$  and  $b = -2$ .)  
 (c) Statement: For all integers  $m, n$ , and  $p$ , if  $m$  divides  $n$  and  $n$  divides  $p$  then  $m$  divides  $p$ . (TRUE)  
 Converse: For all integers  $m$  and  $p$ , if  $m$  divides  $p$ , then for each integer  $n$  it follows that  $m$  divides  $n$  and  $n$  divides  $p$ . (FALSE — let  $m = 1$ ,  $n = 2$ , and  $p = 3$ .)  
 Inverse: For all integers  $m, n$ , and  $p$ , if  $m$  does not divide  $n$  or  $n$  does not divide  $p$ , then  $m$  does not divide  $p$ . (False — let  $m = 1$ ,  $n = 2$ , and  $p = 3$ .)  
 Contrapositive: For all integers  $m$  and  $p$ , if  $m$  does not divide  $p$ , then for each integer  $n$  it follows that  $m$  does not divide  $n$  or  $n$  does not divide  $p$ . (TRUE)  
 (d) Statement:  $\forall x [(x > 3) \rightarrow (x^2 > 9)]$  (TRUE)  
 Converse:  $\forall x [(x^2 > 9) \rightarrow (x > 3)]$  (FALSE — let  $x = -5$ .)  
 Inverse:  $\forall x [(x \leq 3) \rightarrow (x^2 \leq 9)]$  (FALSE — let  $x = -5$ .)  
 Contrapositive:  $\forall x [(x^2 \leq 9) \rightarrow (x \leq 3)]$  (TRUE)  
 (e) Statement:  $\forall x [(x^2 + 4x - 21 > 0) \rightarrow [(x > 3) \vee (x < -7)]]$  (TRUE)  
 Converse:  $\forall x [[(x > 3) \vee (x < -7)] \rightarrow (x^2 + 4x - 21 > 0)]$  (TRUE)  
 Inverse:  $\forall x [(x^2 + 4x - 21 \leq 0) \rightarrow [(x \leq 3) \wedge (x \geq -7)]]$ , or  $\forall x [(x^2 + 4x - 21 \leq 0) \rightarrow (-7 \leq x \leq 3)]$  (TRUE)  
 Contrapositive:  $\forall x [[(x \leq 3) \wedge (x \geq -7)] \rightarrow (x^2 + 4x - 21 \leq 0)]$ , or  $\forall x [(-7 \leq x \leq 3) \rightarrow (x^2 + 4x - 21 \leq 0)]$  (TRUE)

20. For each of the following answers it is possible to have the implication and its contrapositive interchanged. When this happens the corresponding converse and inverse must also be interchanged.

- (a) Implication: If a positive integer is divisible by 21, then it is divisible by 7. (TRUE)  
 Converse: If a positive integer is divisible by 7, then it is divisible by 21. (FALSE — consider the positive integer 14.)

Inverse: If a positive integer is not divisible by 21, then it is not divisible by 7. (FALSE — consider the positive integer 14.)

Contrapositive: If a positive integer is not divisible by 7, then it is not divisible by 21. (TRUE)

(b) Implication: If a snake is a cobra, then it is dangerous.

Converse: If a snake is dangerous, then it is a cobra.

Inverse: If a snake is not a cobra, then it is not dangerous.

Contrapositive: If a snake is not dangerous, then it is not a cobra.

(c) Implication: For each complex number  $z$ , if  $z^2$  is real then  $z$  is real. (FALSE — let  $z = i$ .)

Converse: For each complex number  $z$ , if  $z$  is real then  $z^2$  is real. (TRUE)

Inverse: For each complex number  $z$ , if  $z^2$  is not real then  $z$  is not real. (TRUE)

Contrapositive: For each complex number  $z$ , if  $z$  is not real then  $z^2$  is not real. (FALSE — let  $z = i$ .)

21. (a) True                    (b) False                    (c) False                    (d) True                    (e) False

22. (a) True                    (b) False                    (c) True                    (d) True                    (e) True

23. (a)  $\forall a \exists b [a + b = b + a = 0]$   
(b)  $\exists u \forall a [au = ua = a]$   
(c)  $\forall a \neq 0 \exists b [ab = ba = 1]$   
(d) The statement in part (b) remains true but the statement in part (c) is no longer true for this new universe.

24. (a) True                    (b) False                    (c) False                    (d) True

25. (a)  $\exists x \exists y [(x > y) \wedge (x - y \leq 0)]$   
(b)  $\exists x \exists y [(x < y) \wedge \forall z [x \geq z \vee z \geq y]]$   
(c)  $\exists x \exists y [(|x| = |y|) \wedge (y \neq \pm x)]$

26.  $\lim_{n \rightarrow \infty} r_n \neq L \Leftrightarrow \exists \epsilon > 0 \forall k > 0 \exists n [(n > k) \wedge |r_n - L| \geq \epsilon]$

## Section 2.5

1. Although we may write  $28 = 25 + 1 + 1 + 1 = 16 + 4 + 4 + 4$ , there is no way to express 28 as the sum of at most three perfect squares.
2. Although  $3 = 1 + 1 + 1$  and  $5 = 4 + 1$ , when we get to 7 there is a problem. We can write  $7 = 4 + 1 + 1 + 1$ , but we cannot write 7 as the sum of three or fewer perfect squares. [There is also a problem with the integers 15 and 23.]

3. Here we find that

$$30 = 25 + 4 + 1$$

$$32 = 16 + 16$$

$$34 = 25 + 9$$

$$36 = 36$$

$$38 = 36 + 1 + 1$$

$$40 = 36 + 4$$

$$42 = 25 + 16 + 1$$

$$44 = 36 + 4 + 4$$

$$46 = 36 + 9 + 1$$

$$48 = 16 + 16 + 16$$

$$50 = 25 + 25$$

$$52 = 36 + 16$$

$$54 = 25 + 25 + 4$$

$$56 = 36 + 16 + 4$$

$$58 = 49 + 9$$

4.

$$4 = 2 + 2$$

$$6 = 3 + 3$$

$$8 = 3 + 5$$

$$10 = 5 + 5$$

$$12 = 7 + 5$$

$$14 = 7 + 7$$

$$16 = 13 + 3$$

$$18 = 13 + 5$$

$$20 = 17 + 3$$

$$22 = 17 + 5$$

$$24 = 17 + 7$$

$$26 = 19 + 7$$

$$28 = 23 + 5$$

$$30 = 17 + 13$$

$$32 = 19 + 13$$

$$34 = 17 + 17$$

$$36 = 19 + 17$$

$$38 = 19 + 19$$

5. (a) The real number  $\pi$  is not an integer.  
(b) Margaret is a librarian.  
(c) All administrative directors know how to delegate authority.  
(d) Quadrilateral  $MNPQ$  is not equiangular.
6. (a) Valid — This argument follows from the Rule of Universal Specification and Modus Ponens.  
(b) Invalid — Attempt to argue by the converse.  
(c) Invalid — Attempt to argue by the inverse.
7. (a) When the statement  $\exists x [p(x) \vee q(x)]$  is true, there is at least one element  $c$  in the prescribed universe where  $p(c) \vee q(c)$  is true. Hence at least one of the statements  $p(c), q(c)$  has the truth value 1, so at least one of the statements  $\exists x p(x)$  and  $\exists x q(x)$  is true. Therefore, it follows that  $\exists x p(x) \vee \exists x q(x)$  is true, and  $\exists x [p(x) \vee q(x)] \implies \exists x p(x) \vee \exists x q(x)$ . Conversely, if  $\exists x p(x) \vee \exists x q(x)$  is true, then at least one of  $p(a), q(b)$  has truth value 1, for some  $a, b$  in the prescribed universe. Assume without loss of generality that it is  $p(a)$ . Then  $p(a) \vee q(a)$  has truth value 1 so  $\exists x [p(x) \vee q(x)]$  is a true statement, and  $\exists x p(x) \vee \exists x q(x) \implies \exists x [p(x) \vee q(x)]$ .  
(b) First consider when the statement  $\forall x [p(x) \wedge q(x)]$  is true. This occurs when  $p(a) \wedge q(a)$  is true for each  $a$  in the prescribed universe. Then  $p(a)$  is true (as is  $q(a)$ ) for all  $a$  in the universe, so the statements  $\forall x p(x), \forall x q(x)$  are true. Therefore, the statement  $\forall x p(x) \wedge \forall x q(x)$  is true and  $\forall x [p(x) \wedge q(x)] \implies \forall x p(x) \wedge \forall x q(x)$ . Conversely, suppose that  $\forall x p(x) \wedge \forall x q(x)$  is a true statement. Then  $\forall x p(x), \forall x q(x)$  are both true. So now let  $c$  be any element in the prescribed universe. Then  $p(c), q(c)$ , and  $p(c) \wedge q(c)$  are all true. And, since  $c$  was chosen arbitrarily, it follows that the statement  $\forall x [p(x) \wedge q(x)]$  is true, and  $\forall x p(x) \wedge \forall x q(x) \implies \forall x [p(x) \wedge q(x)]$ .
8. (a) Suppose that the statement  $\forall x p(x) \vee \forall x q(x)$  is true, and suppose without loss of generality that  $\forall x p(x)$  is true. Then for each  $c$  in the given universe  $p(c)$  is true, as is

$p(c) \vee q(c)$ . Hence  $\forall x [p(x) \vee q(x)]$  is true and  $\forall x p(x) \vee \forall x q(x) \implies \forall x [p(x) \vee q(x)]$ .  
 (b) Let  $p(x) : x > 0$  and  $q(x) : x < 0$  for the universe of all nonzero integers. Then  $\forall x p(x), \forall x q(x)$  are false, so  $\forall x p(x) \vee \forall x q(x)$  is false, while  $\forall x [p(x) \vee q(x)]$  is true.

9. (1) Premise  
 (2) Premise  
 (3) Step (1) and the Rule of Universal Specification  
 (4) Step (2) and the Rule of Universal Specification  
 (5) Step (4) and the Rule of Conjunctive Simplification  
 (6) Steps (5), (3), and Modus Ponens  
 (7) Step (6) and the Rule of Conjunctive Simplification  
 (8) Step (4) and the Rule of Conjunctive Simplification  
 (9) Steps (7), (8), and the Rule of Conjunction  
 (10) Step (9) and the Rule of Universal Generalization

10. (4) Step (1) and the Rule of Universal Specification  
 (5) Steps (3), (4), and the Rule of Disjunctive Syllogism  
 (6) Premise  
 (7) Step (6) and the Rule of Universal Specification  
 (8) Step (7) and  $\neg q(a) \vee r(a) \Leftrightarrow q(a) \rightarrow r(a)$   
 (9) Steps (5), (8), and Modus Ponens (or the Rule of Detachment)  
 (10) Premise  
 (11) Step (10) and the Rule of Universal Specification  
 (12) Step (11) and  $s(a) \rightarrow \neg r(a) \Leftrightarrow \neg \neg r(a) \rightarrow \neg s(a) \Leftrightarrow r(a) \rightarrow \neg s(a)$   
 (13) Steps (9), (12), and Modus Ponens (or the Rule of Detachment)

11. Consider the open statements  
 $w(x)$ :  $x$  works for the credit union  
 $\ell(x)$ :  $x$  writes loan applications  
 $c(x)$ :  $x$  knows COBOL  
 $q(x)$ :  $x$  knows Excel

and let  $r$  represent Roxe and  $i$  represent Imogene.

In symbolic form the given argument is given as follows:

$$\begin{array}{l} \forall x [w(x) \rightarrow c(x)] \\ \forall x [(w(x) \wedge \ell(x)) \rightarrow q(x)] \\ w(r) \wedge \neg q(r) \\ \underline{q(i) \wedge \neg c(i)} \\ \therefore \neg \ell(r) \wedge \neg w(i) \end{array}$$

The steps (and reasons) needed to verify this argument can now be presented.

Steps	Reasons
(1) $\forall x [w(x) \rightarrow c(x)]$	Premise
(2) $q(i) \wedge \neg c(i)$	Premise
(3) $\neg c(i)$	Step (2) and the Rule of Conjunctive Simplification
(4) $w(i) \rightarrow c(i)$	Step (1) and the Rule of Universal Specification
(5) $\neg w(i)$	Steps (3), (4), and Modus Tollens
(6) $\forall x [(w(x) \wedge \ell(x)) \rightarrow q(x)]$	Premise
(7) $w(r) \wedge \neg q(r)$	Premise
(8) $\neg q(r)$	Step (7) and the Rule of Conjunctive Simplification
(9) $(w(r) \wedge \ell(r)) \rightarrow q(r)$	Step (6) and the Rule of Universal Specification
(10) $\neg(w(r) \wedge \ell(r))$	Steps (8), (9), and Modus Tollens
(11) $w(r)$	Step (7) and the Rule of Conjunctive Simplification
(12) $\neg w(r) \vee \neg \ell(r)$	Step (10) and DeMorgan's Law
(13) $\neg \ell(r)$	Steps (11), (12), and the Rule of Disjunctive Syllogism
(14) $\therefore \neg \ell(r) \wedge \neg w(i)$	Steps (13), (5), and the Rule of Conjunction

12. (a) Proof: Since  $k, \ell$  are both even we may write  $k = 2c$  and  $\ell = 2d$ , where  $c, d$  are integers. This follows from Definition 2.8. Then the sum  $k + \ell = 2c + 2d = 2(c + d)$  by the distributive law of multiplication over addition for integers. Consequently, by Definition 2.8, it follows from  $k + \ell = 2(c + d)$ , with  $c + d$  an integer, that  $k + \ell$  is even.

(b) Proof: As in part (a) we write  $k = 2c$  and  $\ell = 2d$  for integers  $c, d$ . Then — by the commutative and associative laws of multiplication for integers — the product  $k\ell = (2c)(2d) = 2(2cd)$ , where  $2cd$  is an integer. With  $(2c)(2d) = 2(2cd)$ , and  $2cd$  an integer, it now follows from Definition 2.8 that  $k\ell$  is even.

13. (a) Contrapositive: For all integers  $k$  and  $\ell$ , if  $k, \ell$  are not both odd then  $k\ell$  is not odd. — OR, For all integers  $k$  and  $\ell$ , if at least one of  $k, \ell$  is even then  $k\ell$  is even.

Proof: Let us assume (without loss of generality) that  $k$  is even. Then  $k = 2c$  for some integer  $c$  — because of Definition 2.8. Then  $k\ell = (2c)\ell = 2(c\ell)$ , by the associative law of multiplication for integers — and  $c\ell$  is an integer. Consequently,  $k\ell$  is even — once again, by Definition 2.8. [Note that this result does not require anything about the integer  $\ell$ .]

(b) Contrapositive: For all integers  $k$  and  $\ell$ , if  $k$  and  $\ell$  are not both even or both odd then  $k + \ell$  is odd. — OR, For all integers  $k$  and  $\ell$ , if one of  $k, \ell$  is odd and the other even then  $k + \ell$  is odd.

Proof: Let us assume (without loss of generality) that  $k$  is even and  $\ell$  is odd. Then it follows from Definition 2.8 that we may write  $k = 2c$  and  $\ell = 2d + 1$  for integers  $c$  and  $d$ . And now we find that  $k + \ell = 2c + (2d + 1) = 2(c + d) + 1$ , where  $c + d$  is an integer — by the associative law of addition and the distributive law of multiplication over addition for integers. From Definition 2.8 we find that  $k + \ell = 2(c + d) + 1$  implies that  $k + \ell$  is odd.

14. Proof: Since  $n$  is odd we may write  $n = 2a + 1$ , where  $a$  is an integer — by Definition 2.8. Then  $n^2 = (2a + 1)^2 = 4a^2 + 4a + 1 = 2(2a^2 + 2a) + 1$ , where  $2a^2 + 2a$  is an integer. So again by Definition 2.8 it follows that  $n^2$  is odd.
15. Proof: Assume that for some integer  $n$ ,  $n^2$  is odd while  $n$  is not odd. Then  $n$  is even and we may write  $n = 2a$ , for some integer  $a$  — by Definition 2.8. Consequently,  $n^2 = (2a)^2 = (2a)(2a) = (2 \cdot 2)(a \cdot a)$ , by the commutative and associative laws of multiplication for integers. Hence, we may write  $n^2 = 2(2a^2)$ , with  $2a^2$  an integer — and this means that  $n^2$  is even. Thus we have arrived at a contradiction since we now have  $n^2$  both odd (at the start) and even. This contradiction came about from the false assumption that  $n$  is not odd. Therefore, for every integer  $n$ , it follows that  $n^2$  odd  $\Rightarrow n$  odd.
16. Here we must prove two results — namely, (i) if  $n^2$  is even, then  $n$  is even; and (ii) if  $n$  is even, then  $n^2$  is even.  
 Proof (i): Using the method of contraposition, suppose that  $n$  is not even — that is,  $n$  is odd. Then  $n = 2a + 1$ , for some integer  $a$ , and  $n^2 = (2a + 1)^2 = 4a^2 + 4a + 1 = 2(2a^2 + 2a) + 1$ , where  $2a^2 + 2a$  is an integer. Hence  $n^2$  is odd (or, not even).  
 Proof (ii): If  $n$  is even then  $n = 2c$  for some integer  $c$ . So  $n^2 = (2c)^2 = (2c)(2c) = 2(c(2c)) = 2((c \cdot 2)c) = 2((2c)c) = 2(2c^2)$ , by the associative and commutative laws of multiplication for integers. Since  $2c^2$  is an integer, it follows that  $n^2$  is even.
17. Proof:  
 (1) Since  $n$  is odd we have  $n = 2a + 1$  for some integer  $a$ . Then  $n + 11 = (2a + 1) + 11 = 2a + 12 = 2(a + 6)$ , where  $a + 6$  is an integer. So by Definition 2.8 it follows that  $n + 11$  is even.  
 (2) If  $n + 11$  is not even, then it is odd and we have  $n + 11 = 2b + 1$ , for some integer  $b$ . So  $n = (2b + 1) - 11 = 2b - 10 = 2(b - 5)$ , where  $b - 5$  is an integer, and it follows from Definition 2.8 that  $n$  is even — that is, not odd.  
 (3) In this case we stay with the hypothesis — that  $n$  is odd — and also assume that  $n + 11$  is not even — hence, odd. So we may write  $n + 11 = 2b + 1$ , for some integer  $b$ . This then implies that  $n = 2(b - 5)$ , for the integer  $b - 5$ . So by Definition 2.8 it follows that  $n$  is even. But with  $n$  both even (as shown) and odd (as in the hypothesis) we have arrived at a contradiction. So our assumption was wrong, and it now follows that  $n + 11$  is even for every odd integer  $n$ .
18. Proof: [Here we provide a direct proof.] Since  $m, n$  are perfect squares, we may write  $m = a^2$  and  $n = b^2$ , where  $a, b$  are (positive) integers. Then by the associative and commutative laws of multiplication for integers we find that  $mn = (a^2)(b^2) = (aa)(bb) = ((aa)b)b = (a(ab))b = ((ab)a)b = (ab)(ab) = (ab)^2$ , so  $mn$  is also a perfect square.
19. This result is not true, in general. For example,  $m = 4 = 2^2$  and  $n = 1 = 1^2$  are two positive integers that are perfect squares, but  $m + n = 2^2 + 1^2 = 5$  is not a perfect square.

20. Let  $m = 9 = 3^2$  and  $n = 16 = 4^2$ . Then  $m + n = 25 = 5^2$ , so the result is true.
21. Proof: We shall prove the given result by establishing the truth of its (logically equivalent) contrapositive.  
Let us consider the negation of the conclusion — that is,  $x < 50$  and  $y < 50$ . Then with  $x < 50$  and  $y < 50$  it follows that  $x + y < 50 + 50 = 100$ , and we have the negation of the hypothesis. The given result now follows by this indirect method of proof (by the contrapositive).
22. Proof: Since  $4n + 7 = 4n + 6 + 1 = 2(2n + 3) + 1$ , it follows from Definition 2.8 that  $4n + 7$  is odd.
23. Proof: If  $n$  is odd, then  $n = 2k + 1$  for some (particular) integer  $k$ . Then  $7n + 8 = 7(2k + 1) + 8 = 14k + 7 + 8 = 14k + 15 = 14k + 14 + 1 = 2(7k + 7) + 1$ . It then follows from Definition 2.8 that  $7n + 8$  is odd.

To establish the converse, suppose that  $n$  is not odd. Then  $n$  is even, so we can write  $n = 2t$ , for some (particular) integer  $t$ . But then  $7n + 8 = 7(2t) + 8 = 14t + 8 = 2(7t + 4)$ , so it follows from Definition 2.8 that  $7n + 8$  is even — that is,  $7n + 8$  is not odd. Consequently, the converse follows by contraposition.

24. Proof: If  $n$  is even, then  $n = 2k$  for some (particular) integer  $k$ . Then  $31n + 12 = 31(2k) + 12 = 62k + 12 = 2(31k + 6)$ , so it follows from Definition 2.8 that  $31n + 12$  is even.

Conversely, suppose that  $n$  is not even. Then  $n$  is odd, so  $n = 2t + 1$  for some (particular) integer  $t$ . Therefore,  $31n + 12 = 31(2t + 1) + 12 = 62t + 31 + 12 = 62t + 43 = 2(31t + 21) + 1$ , so from Definition 2.8 we have  $31n + 12$  odd — hence, not even. Consequently, the converse follows by contraposition.

## Supplementary Exercises

1.

$p$	$q$	$r$	$s$	$q \wedge r$	$\neg(s \vee r)$	$\overbrace{[(q \wedge r) \rightarrow \neg(s \vee r)]}^t$	$p \leftrightarrow t$
0	0	0	0	0	1	1	0
0	0	0	1	0	0	1	0
0	0	1	0	0	0	1	0
0	0	1	1	0	0	1	0
0	1	0	0	0	1	1	0
0	1	0	1	0	0	1	0
0	1	1	0	1	0	0	1
0	1	1	1	1	0	0	1
1	0	0	0	0	1	1	1
1	0	0	1	0	0	1	1
1	0	1	0	0	0	1	1
1	0	1	1	0	0	1	1
1	1	0	0	0	1	1	1
1	1	0	1	0	0	1	1
1	1	1	0	1	0	0	0
1	1	1	1	1	0	0	0

2. (a)

$p$	$q$	$r$	$p \rightarrow q$	$\neg p \rightarrow r$	$(p \rightarrow q) \wedge (\neg p \rightarrow r)$
0	0	0	1	0	0
0	0	1	1	1	1
0	1	0	1	0	0
0	1	1	1	1	1
1	0	0	0	1	0
1	0	1	0	1	0
1	1	0	1	1	1
1	1	1	1	1	1

(b) If  $p$ , then  $q$ , else  $r$ .

3. (a)

$p$	$q$	$r$	$q \leftrightarrow r$	$p \leftrightarrow (q \leftrightarrow r)$	$(p \leftrightarrow q)$	$(p \leftrightarrow q) \leftrightarrow r$
0	0	0	1	0	1	0
0	0	1	0	1	1	1
0	1	0	0	1	0	1
0	1	1	1	0	0	0
1	0	0	1	1	0	1
1	0	1	0	0	0	0
1	1	0	0	0	1	0
1	1	1	1	1	1	1

It follows from the results in columns 5 and 7 that  $[p \leftrightarrow (q \leftrightarrow r)] \Leftrightarrow [(p \leftrightarrow q) \leftrightarrow r]$ .

(b) The truth value assignments  $p : 0; q : 0; r : 0$  result in the truth value 1 for  $[p \rightarrow (q \rightarrow r)]$  and 0 for  $[(p \rightarrow q) \rightarrow r]$ . Consequently, these statements are not logically equivalent.

4.  $p \leftrightarrow q \Leftrightarrow (p \rightarrow q) \wedge (q \rightarrow p) \Leftrightarrow (\neg p \vee q) \wedge (\neg q \vee p)$ , so  $\neg(p \leftrightarrow q) \Leftrightarrow \neg(\neg p \vee q) \vee \neg(\neg q \vee p) \Leftrightarrow (p \wedge \neg q) \vee (q \wedge \neg p)$

5. Since  $p \vee \neg q \Leftrightarrow \neg\neg p \vee \neg q \Leftrightarrow \neg p \rightarrow \neg q$ , we can express the given statement as:

(1) If Kaylyn does not practice her piano lessons, then she cannot go to the movies.

But  $p \vee \neg q \Leftrightarrow \neg q \vee p \Leftrightarrow q \rightarrow p$ , so we can also express the given statement as:

(2) If Kaylyn is to go to the movies, then she will have to practice her piano lessons.

6. a)  $p \rightarrow (q \wedge r)$

Converse:  $(q \wedge r) \rightarrow p$

Inverse:  $[\neg p \rightarrow \neg(q \wedge r)] \Leftrightarrow [\neg p \rightarrow (\neg q \vee \neg r)]$

Contrapositive:  $[\neg(q \wedge r) \rightarrow \neg p] \Leftrightarrow [(\neg q \vee \neg r) \rightarrow \neg p]$

b)  $(p \vee q) \rightarrow r$

Converse:  $r \rightarrow (p \vee q)$

Inverse:  $[\neg(p \vee q) \rightarrow \neg r] \Leftrightarrow [(\neg p \wedge \neg q) \rightarrow \neg r]$

Contrapositive:  $[\neg r \rightarrow \neg(p \vee q)] \Leftrightarrow [\neg r \rightarrow (\neg p \wedge \neg q)]$

7.

(a)  $(\neg p \vee \neg q) \wedge (F_0 \vee p) \wedge p$

(b)  $(\neg p \vee \neg q) \wedge (F_0 \vee p) \wedge p$

$\Leftrightarrow (\neg p \vee \neg q) \wedge (p \wedge p)$

$\Leftrightarrow (\neg p \vee \neg q) \wedge p$

$\Leftrightarrow p \wedge (\neg p \vee \neg q)$

$\Leftrightarrow (p \wedge \neg p) \vee (p \wedge \neg q)$

$\Leftrightarrow F_0 \vee (p \wedge \neg q)$

$\Leftrightarrow p \wedge \neg q$

$F_0 \vee p \Leftrightarrow p$

Idempotent Law of  $\wedge$

Commutative Law of  $\wedge$

Distributive Law of  $\wedge$  over  $\vee$

$p \wedge \neg p \Leftrightarrow F_0$

$F_0$  is the identity for  $\vee$ .

8. (a)  $(p \wedge \neg q) \vee (\neg r \wedge s)$   
 (b) Since  $p \rightarrow (q \wedge \neg r \wedge s) \Leftrightarrow \neg p \vee (q \wedge \neg r \wedge s)$  it follows that  $[p \rightarrow (q \wedge \neg r \wedge s)]^d \Leftrightarrow \neg p \wedge (q \vee \neg r \vee s)$ .  
 (c)  $[(p \wedge F_0) \vee (q \wedge T_0)] \wedge [r \vee s \vee F_0]$

9.

- (a) contrapositive      (b) inverse                      (c) contrapositive  
 (d) inverse                      (e) converse

### 10. Proof by Contradiction

- |      |   |   |
|------|---|---|
| (1)  | $\neg(p \rightarrow s)$                 | Premise (Negation of Conclusion)  |
| (2)  | $p \wedge \neg s$                       | Step (1), $(p \rightarrow s) \Leftrightarrow \neg p \vee s$ , DeMorgan's Laws, and the Law of Double Negation |
| (3)  | $p$                                     | Step (2) and the Rule of Conjunctive Simplification   |
| (4)  | $p \rightarrow q$                       | Premise   |
| (5)  | $q$                                     | Steps (3), (4), and the Rule of Detachment  |
| (6)  | $r$                                     | Premise   |
| (7)  | $q \wedge r$                            | Steps (5), (6), and the Rule of Conjunction   |
| (8)  | $(q \wedge r) \rightarrow s$            | Premise   |
| (9)  | $s$                                     | Steps (7), (8), and the Rule of Detachment  |
| (10) | $\neg s$                                | Step (2) and the Rule of Conjunctive Simplification   |
| (11) | $s \wedge \neg s (\Leftrightarrow F_0)$ | Steps (9), (10), and the Rule of Conjunction  |
| (12) | $\therefore p \rightarrow s$            | Steps (1), (11), and the Method of Proof by Contradiction   |

### Method 2

- |     |                                   |  |
|-----|-----------------------------------|--|
| (1) | $(q \wedge r) \rightarrow s$      | Premise  |
| (2) | $r \rightarrow (q \rightarrow s)$ | $r \rightarrow (q \rightarrow s) \Leftrightarrow (q \wedge r) \rightarrow s$ |
| (3) | $r$                               | Premise  |
| (4) | $q \rightarrow s$                 | Steps (2), (3), and Modus Ponens   |
| (5) | $p \rightarrow q$                 | Premise  |
| (6) | $\therefore p \rightarrow s$      | Steps (4), (5), and the Law of the Syllogism                                 |

Method 3

- (1)  $(q \wedge r) \rightarrow s$  Premise
- (2)  $\neg s \rightarrow \neg(q \wedge r)$  Step (1) and for primitive statements  $u, v$   
 $u \rightarrow v \Leftrightarrow \neg v \rightarrow \neg u$  – and the 1st Substitution Rule.
- (3)  $s \vee \neg(q \wedge r)$  Step (2) and for primitive statements  $u, v, u \rightarrow v \Leftrightarrow \neg u \vee v$  –  
and the 1st Substitution Rule. Also,  $\neg\neg s \Leftrightarrow s$ .
- (4)  $(s \vee \neg q) \vee \neg r$  Step (3), DeMorgan's Law, and the Associative Law of  $\vee$
- (5)  $r$  Premise
- (6)  $s \vee \neg q$  Steps (4), (5), and the Law of Disjunctive Syllogism
- (7)  $q \rightarrow s$  Step (6) and  $s \vee \neg q \Leftrightarrow \neg q \vee s \Leftrightarrow q \rightarrow s$
- (8)  $p \rightarrow q$  Premise
- (9)  $\therefore p \rightarrow s$  Steps (7), (8), and the Law of the Syllogism

Method 4 (Here we assume  $p$  as an additional premise and obtain  $s$  as our conclusion.)

- (1)  $p$  Premise (assumed)
- (2)  $p \rightarrow q$  Premise
- (3)  $q$  Steps (1), (2), and Modus Ponens
- (4)  $r$  Premise
- (5)  $q \wedge r$  Steps (3), (4), and the Rule of Conjunction
- (6)  $(q \wedge r) \rightarrow s$  Premise
- (7)  $\therefore s$  Steps (5), (6), and Modus Ponens

11. (a)

$p$	$q$	$r$	$p \vee q$	$(p \vee q) \vee r$	$q \vee r$	$p \vee (q \vee r)$
0	0	0	0	0	0	0
0	0	1	0	1	1	1
0	1	0	1	1	1	1
0	1	1	1	0	0	0
1	0	0	1	1	0	1
1	0	1	1	0	1	0
1	1	0	0	0	1	0
1	1	1	0	1	0	1

It follows from the results in columns 5 and 7 that  $[(p \vee q) \vee r] \Leftrightarrow [p \vee (q \vee r)]$ .

(b) The given statements are not logically equivalent. The truth value assignments  $p : 1; q : 0; r : 0$  provide a counterexample.

12.  $p$ : The temperature is cool on Friday.  
 $q$ : Craig wears his suede jacket.  
 $r$ : The pockets (of the suede jacket) are mended.

$$p \rightarrow (r \rightarrow q)$$

$$\frac{p \wedge \neg r}{\therefore \neg q}$$

The argument is invalid. The truth value assignments  $p : 1$ ;  $q : 1$ ;  $r : 0$  provide a counterexample.

13. (a) True (b) False (c) True (d) True  
(e) False (f) False (g) False (h) True
14. a) This statement is true. Note that  $1 = 7(-2) + 5(3)$ , so for each integer  $x$ ,  $x = 7(-2x) + 5(3x)$ .  
b) Since 2 divides both 4 and 6, it follows that 2 divides  $4y + 6z$ . Consequently, the result is false for each odd integer  $x$ . [Since  $2 = 4(-1) + 6(1)$ , the result is true for each even integer  $x$ .]
15. Suppose that the 62 squares in this  $8 \times 8$  chessboard (with two opposite missing corners) can be covered with 31 dominos. We agree to place each domino on the board so that the blue part is on top of a blue square (and the white part is then necessarily above a white square). The given chessboard contains 30 blue squares and 32 white ones. Each domino covers one blue and one white square – for a total of 31 blue squares and 31 white ones. This contradiction tells us that we cannot cover this 62 square chessboard with the 31 dominos.
16. Suppose that the 60 squares in the  $8 \times 8$  chessboard (with two squares – one blue and one white – removed from each of two opposite corners) can be covered with 15 of these T-shaped figures. When covering the chessboard we agree to place each T-shaped figure on the board so that the color of each square in the T-shaped figure matches the color of the chessboard square that it covers. Let  $n$  be the number of T-shaped figures with three blue squares (and one white one) used in the covering. The chessboard contains 30 blue squares, so it follows that

$$3n + 1 \cdot (15n - n) = 30.$$

Consequently,  $2n = 15$  – so 15 is both odd and even. This contradiction tells us that we cannot cover the given chessboard with these T-shaped figures.

CHAPTER 3  
SET THEORY

**Section 3.1**

1. They are all the same set.
2. All of the statements are true except for part (f).
3. All of the statements are true except for parts (b) and (d).
4. All of the statements are true except for parts (a) and (b).
5. (a)  $\{0, 2\}$   
 (b)  $\{2, 2\frac{1}{2}, 3\frac{1}{3}, 5\frac{1}{5}, 7\frac{1}{7}\}$   
 (c)  $\{0, 2, 12, 36, 80\}$
6. (a) True (b) True (c) True  
 (d) False (e) True (f) False
7. (a)  $\forall x [x \in A \rightarrow x \in B] \wedge \exists x [x \in B \wedge x \notin A]$   
 (b)  $\exists x [x \in A \wedge x \notin B] \vee \forall x [x \notin B \vee x \in A]$
8. (a)  $2^7 = 128$  (b)  $128 - 1 = 127$  (We subtract 1 for  $\emptyset$ ).  
 (c)  $128 - 1 = 127$  (We subtract 1 for  $A$ ) (d) 126 (e)  $\binom{7}{3} = 35$   
 (f) For each of the other five elements of  $A$  there are two choices: Include it with 1,2 in a subset or exclude it from a subset that contains 1,2. By the rule of product there are  $2^5$  subsets containing 1,2.  
 (g)  $\binom{5}{3}$  (h)  $\binom{7}{0} + \binom{7}{2} + \binom{7}{4} + \binom{7}{6} = 64$  (i)  $\binom{7}{1} + \binom{7}{3} + \binom{7}{5} + \binom{7}{7} = 64$
9. (a)  $|A| = 6$  (b)  $|B| = 7$   
 (c) If  $B$  has  $2^n$  subsets of odd cardinality, then  $|B| = n + 1$ .
10. The only nonempty sets are in parts (d) and (f).
11. (a) There are  $2^5 - 1 = 31$  nonempty subsets for the set consisting of one penny, one nickel, one dime, one quarter and one half-dollar.  
 (b) 30 (c) 28

12. (a)  $\binom{12}{6} = 924$  (b)  $\binom{6}{4}\binom{6}{2} = 225$  (c)  $2^5 - 1 = 63$

13. (a)  $\binom{30}{5}$   
 (b) Since the smallest element in  $A$  is 5 we must select the other four elements in  $A$  from  $\{6, 7, 8, \dots, 29, 30\}$ . This can be done in  $\binom{25}{4}$  ways.

(c) Let  $x$  denote the smallest element in  $A$ . Then there are four cases to consider.

( $x = 1$ ) Here we can choose the other four elements in  $\binom{29}{4}$  ways.

( $x = 2$ ) Here there are  $\binom{28}{4}$  selections.

( $x = 3$ ) There are  $\binom{27}{4}$  subsets possible here.

( $x = 4$ ) In this last case we have  $\binom{26}{4}$  possibilities.

In total there are  $\binom{29}{4} + \binom{28}{4} + \binom{27}{4} + \binom{26}{4}$  subsets  $A$  where  $|A| = 5$  and the smallest element in  $A$  is less than 5.

14. (a) There are  $2^{11}$  subsets for  $\{1, 2, 3, \dots, 11\}$ , and  $2^6$  subsets for  $\{1, 3, 5, 7, 9, 11\}$ . The  $2^6$  subsets of  $\{1, 3, 5, 7, 9, 11\}$  contain none of the even integers 2, 4, 6, 8, 10. Hence, there are  $2^{11} - 2^6 = 1984$  subsets of  $\{1, 2, 3, \dots, 11\}$  that contain at least one even integer.

(b)  $2^{12} - 2^6 = 4032$

(c) For  $n = 2k + 1$ , where  $k \geq 0$ , the number of subsets of  $\{1, 2, 3, \dots, n\}$  containing at least one even integer is  $2^n - 2^{k+1}$ .

For  $n = 2k$ , with  $k \geq 1$ , the number of such subsets is  $2^n - 2^k$ .

15. Let  $W = \{1\}$ ,  $X = \{\{1\}, 2\}$ ,  $Y = \{X, 3\}$ .

16.

$(n = 6)$		1	6	15	20	15	6	1	
$(n = 7)$	1	7	21	35	35	21	7	1	
$(n = 8)$	1	8	28	56	70	56	28	8	1

17. (a) Let  $x \in A$ . Since  $A \subseteq B$ ,  $x \in B$ . Then with  $B \subseteq C$ ,  $x \in C$ . So  $x \in A \implies x \in C$  and  $A \subseteq C$ .

(b) Since  $A \subset B \implies A \subseteq B$ , by part (a),  $A \subseteq C$ . With  $A \subset B$ , there is an element  $x \in B$  such that  $x \notin A$ . Since  $B \subseteq C$ ,  $x \in B \implies x \in C$ , so there is an element  $x \in C$  with  $x \notin A$  and  $A \subset C$ .

(c) Since  $B \subset C$  it follows that  $B \subseteq C$ , so by part (a) we have  $A \subseteq C$ . Also,  $B \subset C \implies \exists x \in \mathcal{U} (x \in C \wedge x \notin B)$ . Since  $A \subseteq B$ ,  $x \notin B \implies x \notin A$ . So  $A \subseteq C$  and  $\exists x \in \mathcal{U} (x \in C \wedge x \notin A)$ . Hence  $A \subset C$ .

(d) Since  $A \subset B \implies A \subseteq B$ , the result follows from part (c).

18. False. Let  $A = \{1\}$ ,  $B = \{1, 2\}$ , and  $C = \{1, 3\}$ .

19. (a) For  $n, k \in \mathbf{Z}^+$  with  $n \geq k + 1$ , consider the hexagon centered at  $\binom{n}{k}$ . This has the form

$$\begin{array}{ccccc} & & \binom{n-1}{k-1} & & \binom{n-1}{k} \\ & & & & \\ \binom{n}{k-1} & & \binom{n}{k} & & \binom{n}{k+1} \\ & & & & \\ \binom{n+1}{k} & & & & \binom{n+1}{k+1} \end{array}$$

where the two alternating triples – namely,  $\binom{n-1}{k-1}, \binom{n}{k+1}, \binom{n+1}{k}$  and  $\binom{n-1}{k}, \binom{n+1}{k+1}, \binom{n}{k-1}$  – satisfy  $\binom{n-1}{k-1} \binom{n}{k+1} \binom{n+1}{k} = \binom{n-1}{k} \binom{n+1}{k+1} \binom{n}{k-1}$ .

- (b) For  $n, k \in \mathbf{Z}^+$  with  $n \geq k + 1$ ,

$$\begin{aligned} \binom{n-1}{k-1} \binom{n}{k+1} \binom{n+1}{k} &= \left[ \frac{(n-1)!}{(k-1)!(n-k)!} \right] \left[ \frac{n!}{(k+1)!(n-k-1)!} \right] \left[ \frac{(n+1)!}{k!(n+1-k)!} \right] \\ &= \left[ \frac{(n-1)!}{k!(n-1-k)!} \right] \left[ \frac{(n+1)!}{(k+1)!(n-k)!} \right] \left[ \frac{n!}{(k-1)!(n-k+1)!} \right] = \\ &\binom{n-1}{k} \binom{n+1}{k+1} \binom{n}{k-1}. \end{aligned}$$

20. (a) Each of these strictly increasing sequences of integers corresponds with a subset of  $\{2, 3, 4, 5, 6\}$ . Therefore there are  $2^5$  such strictly increasing sequences.

(b)  $2^5$

(c)  $2^{35}$  and  $2^{36}$

(d) Let  $m, n$  be positive integers with  $m < n$ . The number of strictly increasing sequences of integers that start with  $m$  and end with  $n$  is  $2^{\lfloor (n-m)+1 \rfloor - 2} = 2^{n-m-1}$ .

21.  $(1/4) \binom{n}{5} = \binom{n-1}{4} \implies (1/4)[(n!)/(5!(n-5)!)] = (n-1)!/(4!(n-5)!) \implies n! = 20(n-1)! \implies n = 20$ .

22. a)  $2n$

b)  $4n = 2^2 n$

c)  $2^k n$

23. For a given  $n \in \mathbf{N}$ , we need to find  $k \in \mathbf{N}$  so that the three consecutive entries  $\binom{n}{k}, \binom{n}{k+1}, \binom{n}{k+2}$  are in the ratio  $1 : 2 : 3$ . [Consequently,  $n \geq 2$  (and  $k \geq 0$ ).] In order to obtain the given ratio we must have

$$\binom{n}{k+1} = 2 \binom{n}{k} \quad \text{and} \quad \binom{n}{k+2} = 3 \binom{n}{k}.$$

From  $\binom{n}{k+1} = 2 \binom{n}{k}$ , it follows that  $2 \frac{n!}{(k+1)!(n-k-1)!} = \frac{n!}{k!(n-k)!}$  so  $2k + 2 = n - k$ , or  $n = 2 + 3k$ . Likewise,  $\binom{n}{k+2} = 3 \binom{n}{k}$  implies that  $3 \frac{n!}{(k+2)!(n-k-2)!} = \frac{n!}{k!(n-k)!}$ , and we find that  $3(k+2)(k+1) = (n-k)(n-k-1)$ . Consequently, with  $n = 2 + 3k$ , we have  $3(k+2)(k+1) =$

$(2 + 2k)(1 + 2k)$ , or  $0 = k^2 - 3k - 4 = (k - 4)(k + 1)$ . Since  $k \geq 0$ , it follows that  $k = 4$  and  $n = 14$ . So the 5th, 6th, and 7th entries in the row for  $n = 14$  provide the unique solution.

24.

0000	$\emptyset$	0011	$\{y, z\}$
1000	$\{w\}$	1011	$\{w, y, z\}$
1100	$\{w, x\}$	1111	$\{w, x, y, z\}$
0100	$\{x\}$	0111	$\{x, y, z\}$
0110	$\{x, y\}$	0101	$\{x, z\}$
1110	$\{w, x, y\}$	1101	$\{w, x, z\}$
1010	$\{w, y\}$	1001	$\{w, z\}$
0010	$\{y\}$	0001	$\{z\}$

25. As an ordered set,  $A = \{x, v, w, z, y\}$ .

26. 
$$\binom{n}{0} + \binom{n+1}{1} + \binom{n+2}{2} + \binom{n+3}{3} + \dots + \binom{n+r-1}{r-1} + \binom{n+r}{r} = \binom{n+1}{0} + \binom{n+1}{1} + \binom{n+2}{2} + \binom{n+3}{3} + \dots + \binom{n+r-1}{r-1} + \binom{n+r}{r} = \binom{n+2}{1} + \binom{n+2}{2} + \binom{n+3}{3} + \dots + \binom{n+r-1}{r-1} + \binom{n+r}{r} = \binom{n+3}{2} + \binom{n+3}{3} + \dots + \binom{n+r-1}{r-1} + \binom{n+r}{r} = \binom{n+4}{3} + \dots + \binom{n+r-1}{r-1} + \binom{n+r}{r} = \dots = \binom{n+r}{r-1} + \binom{n+r}{r} = \binom{n+r-1}{r}$$

27. (a) If  $S \in S$ , then since  $S = \{A | A \notin A\}$  we have  $S \notin S$ .

(b) If  $S \notin S$ , then by the definition of  $S$  it follows that  $S \in S$ .

28. (b)

```

10 Random
20 Dim B(12), S(6)
30 B(1) = 2: B(2) = 3: B(3) = 5: B(4) = 7
40 B(5) = 11: B(6) = 13: B(7) = 17: B(8) = 19
50 B(9) = 23: B(10) = 29: B(11) = 31: B(12) = 37
60 For I = 1 To 6
70     S(I) = Int(Rnd*40) + 1
80     For J = 1 To I - 1
90         If S(J) = S(I) Then GOTO 70
100    Next J
110 Next I
120 For I = 1 To 6
130     For J = 1 To 12
140         If S(I) = B(J) Then GOTO 170
150     Next J
160     GOTO 240
170 Next I
180 Print "The subset S contains the elements";

```

```

190 For I = 1 To 5
200     Print S(I); ", ";
210 Next I
220 Print S(6); " and is a subset of B"
230 GOTO 290
240 Print "The subset S contains the elements";
250 For I = 1 To 5
260     Print S(I); ", ";
270 Next I
280 Print S(6); " but it is not a subset of B"
290 End

```

29.

```

procedure Subsets4(i,j,k,l: positive integers)
begin
    for i := 1 to 4 do
        for j := i+1 to 5 do
            for k := j+1 to 6 do
                for l := k+1 to 7 do
                    print ({i,j,k,l})
end

```

30.

```

Program List_subsets4 (Input, Output);
Const
    Size = 10;
Type
    Member_type = 1..Size;
    Set_type = set of Member_type;
Var
    n: 1..Size;
    S: Set_type;

Procedure Write_set (S: Set_type);
Var
    i: 1..Size;
Begin
    Write ('{');
    For i := 1 to Size do

```

```

    If i in S then
        Begin
            S := S - [i];
            If S <> [ ], then
                Write (i:3, ',')
            Else Write (i: 3);
        End;
    Writeln ('}');
End;

Procedure Subsets (L,R : Set.type; i: Member.type);
Begin
    If i <= n then
        Begin
            Subsets (L + [i], R, i+1);
            Subsets (L, R + [i], i+1);
        End
    Else
        Begin
            Write_set (L);
            Write_set (R);
        End;
End;

Begin
    Write ('What is the value of n?');
    Readln (n);
    Subsets ([1],[ ],2);
End.

```

### Section 3.2

1.
 

(a) {1,2,3,5}	(b) A	(c) $\mathcal{U} - \{2\}$
(d) $\mathcal{U} - \{2\}$	(e) {4,8}	(f) {1,2,3,4,5,8}
(g) $\emptyset$	(h) {2,4,8}	(i) {1,3,4,5,8}
2.
 

(a) [2,3]	(b) [0,7)	(c) $(-\infty, 0) \cup (3, +\infty)$
(d) [0,2) $\cup$ (3, 7)	(e) [0,2)	(f) (3,7)
3. (a) Since  $A = (A - B) \cup (A \cap B)$  we have  $A = \{1, 3, 4, 7, 9, 11\}$ . Similarly we find  $B = \{2, 4, 6, 8, 9\}$ .

(b)  $C = \{1, 2, 4, 5, 9\}$ ,  $D = \{5, 7, 8, 9\}$ .

4.

(a) (i) True (ii) False (iii) False  
 (iv) True (v) True (vi) False

(b) (i)  $E$  (ii)  $B$  (iii)  $D$   
 (iv)  $D$  (v)  $\mathbf{Z} - A = \{2n + 1 | n \in \mathbf{Z}\} =$  The set of all (vi)  $E$   
 (positive and negative) odd integers

5.

(a) True (b) True (c) True (d) False (e) True  
 (f) True (g) True (h) False (i) False

6. (a)  $x \in A \cap C \implies (x \in A \text{ and } x \in C) \implies (x \in B \text{ and } x \in D)$ , since  $A \subseteq B$  and  $C \subseteq D \implies x \in B \cap D$ , so  $A \cap C \subseteq B \cap D$ .

$x \in A \cup C \implies x \in A$  or  $x \in C$ . If  $x \in A$ , then  $x \in B$ , since  $A \subseteq B$ . Likewise,  $x \in C \implies x \in D$ . In either case,  $x \in A \cup C \implies x \in B \cup D$ , so  $A \cup C \subseteq B \cup D$ .

(b) Let  $A \subseteq B$ . We always have  $\emptyset \subseteq A \cap \overline{B}$ , so let  $x \in A \cap \overline{B}$ . Then  $x \in A$  and  $x \in \overline{B}$ .  $x \in A \implies x \in B$ , since  $A \subseteq B$ .  $x \in B$ ,  $x \in \overline{B} \implies x \in B \cap \overline{B} = \emptyset$ , so  $A \cap \overline{B} = \emptyset$ . Conversely, for  $A \cap \overline{B} = \emptyset$ , let  $x \in A$ . If  $x \notin B$ , then  $x \in \overline{B}$ , so  $x \in A \cap \overline{B} = \emptyset$ . Hence  $x \in B$  and  $A \subseteq B$ .

(c) Follows from part (b) by the principle of duality.

7. (a) False. Let  $\mathcal{U} = \{1, 2, 3\}$ ,  $A = \{1\}$ ,  $B = \{2\}$ ,  $C = \{3\}$ . Then  $A \cap C = B \cap C$  but  $A \neq B$ .

(b) False. Let  $\mathcal{U} = \{1, 2\}$ ,  $A = \{1\}$ ,  $B = \{2\}$ ,  $C = \{1, 2\}$ . Then  $A \cup B = A \cup C$  but  $A \neq B$ .

(c)  $x \in A \implies x \in A \cup C \implies x \in B \cup C$ . So  $x \in B$  or  $x \in C$ . If  $x \in B$ , then we are finished. If  $x \in C$ , then  $x \in A \cap C = B \cap C$  and  $x \in B$ . In either case,  $x \in B$  so  $A \subseteq B$ . Likewise,  $y \in B \implies y \in B \cup C = A \cup C$ , so  $y \in A$  or  $y \in C$ . If  $y \in C$ , then  $y \in B \cap C = A \cap C$ . In either case,  $y \in A$  and  $B \subseteq A$ . Hence  $A = B$ .

(d) Let  $x \in A$ . Consider two cases: (i)  $x \in C \implies x \notin A \Delta C \implies x \notin B \Delta C \implies x \in B$ .

(ii)  $x \notin C \implies x \in A \Delta C \implies x \notin B \Delta C \implies x \in B$ . In either case  $A \subseteq B$ . In a similar way we find  $B \subseteq A$ , so  $A = B$ .

8. (a)



$$A \Delta (B \cap C)$$

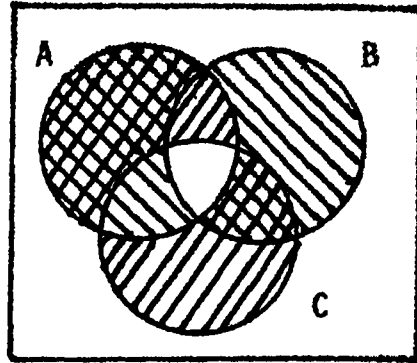

$$(A \Delta B) \cap (A \Delta C)$$

From the Venn diagrams it follows that  $A \Delta (B \cap C) \neq (A \Delta B) \cap (A \Delta C)$ , so the result is false.

(b) True

(c) True

9.  $(A \cap B) \cup C = \{d, x, z\}$  which has  $2^3 - 1 = 7$  proper subsets;  $A \cap (B \cup C) = \{d\}$  which has 1 proper subset.

10. (a) 0

(b) 0 and 1

11. (a)  $\emptyset = (A \cup B) \cap (A \cup \bar{B}) \cap (\bar{A} \cup B) \cap (\bar{A} \cup \bar{B})$

(b)  $A = A \cup (A \cap B)$

(c)  $A \cap B = (A \cup B) \cap (A \cup \bar{B}) \cap (\bar{A} \cup B)$

(d)  $A = (A \cap B) \cup (A \cap \bar{B})$

12. The dual of the statement  $A \cap B = A$  is the statement  $A \cup B = A$ . But  $A \cup B = A \iff B \subseteq A$ , so the dual of the statement  $A \subseteq B$  is the statement  $B \subseteq A$ .

13. (a) False. Let  $\mathcal{U} = \{1, 2, 3\}$ ,  $A = \{1\}$ ,  $B = \{2\}$ .  $P(A) = \{\emptyset, A\}$ ,  $P(B) = \{\emptyset, B\}$ ,  $P(A \cup B) = \{\emptyset, \{1\}, \{2\}, \{1, 2\}\}$ , and  $\{1, 2\} \notin P(A) \cup P(B)$ .

(b)  $X \in P(A) \cap P(B) \iff X \in P(A) \text{ and } X \in P(B) \iff X \subseteq A \text{ and } X \subseteq B \iff X \subseteq A \cap B \iff X \in P(A \cap B)$ , so  $P(A) \cap P(B) = P(A \cap B)$ .

14. (a) & (c)

A	B	$A \cap B$	$\overline{A \cap B}$	$\bar{A} \cup \bar{B}$	$A \cup (A \cap B)$
0	0	0	1	1	0
0	1	0	1	1	0
1	0	0	1	1	1
1	1	1	0	0	1

(b)

$A$	$A \cup A$
0	0
1	1

(d)

$A$	$B$	$C$	$A \cap B$	$\bar{A} \cap C$	$\overline{(A \cap B) \cup (\bar{A} \cap C)}$
0	0	0	0	0	1
0	0	1	0	1	0
0	1	0	0	0	1
0	1	1	0	1	0
1	0	0	0	0	1
1	0	1	0	0	1
1	1	0	1	0	0
1	1	1	1	0	0

$A \cap \bar{B}$	$\bar{A} \cap \bar{C}$	$(A \cap \bar{B}) \cup (\bar{A} \cap \bar{C})$
0	1	1
0	0	0
0	1	1
0	0	0
1	0	1
1	0	1
0	0	0
0	0	0

15. (a)  $2^6 = 64$

(b)  $2^n$

(c) In the columns for  $A, B$ , whenever a 1 occurs in the column for  $A$ , a 1 likewise occurs in the same position in the column for  $B$ .

(d)

A	B	C	$A \cup \bar{B}$	$A \cap B$	$\overline{B \cap C}$	$(A \cap B) \cup \overline{(B \cap C)}$
0	0	0	1	0	1	1
0	0	1	1	0	1	1
0	1	0	0	0	1	1
0	1	1	0	0	0	0
1	0	0	1	0	1	1
1	0	1	1	0	1	1
1	1	0	1	1	1	1
1	1	1	1	1	0	1

16.

Steps

Reasons

$$\begin{aligned}
 & (A \cap B) \cup [B \cap ((C \cap D) \cup (C \cap \bar{D}))] \\
 = & (A \cap B) \cup [B \cap (C \cap (D \cup \bar{D}))] && \text{Distributive Law of } \cap \text{ over } \cup \\
 = & (A \cap B) \cup [B \cap (C \cap \mathcal{U})] && D \cup \bar{D} = \mathcal{U} \\
 = & (A \cap B) \cup (B \cap C) && \text{Identity Law } [C \cap \mathcal{U} = C] \\
 = & (B \cap A) \cup (B \cap C) && \text{Commutative Law of } \cap \\
 = & B \cap (A \cup C) && \text{Distributive Law of } \cap \text{ over } \cup
 \end{aligned}$$

17. (a)  $A \cap (B - A) = A \cap (B \cap \bar{A}) = B \cap (A \cap \bar{A}) = B \cap \emptyset = \emptyset$   
 (b)  $[(A \cap B) \cup (A \cap B \cap \bar{C} \cap D)] \cup (\bar{A} \cap B) = (A \cap B) \cup (\bar{A} \cap B)$  by the Absorption Law  
 $= (A \cup \bar{A}) \cap B = \mathcal{U} \cap B = B$   
 (c)  $(A - B) \cup (A \cap B) = (A \cap \bar{B}) \cup (A \cap B) = A \cap (\bar{B} \cup B) = A \cap \mathcal{U} = A$   
 (d)  $\overline{A \cup \bar{B} \cup (A \cap B \cap \bar{C})} = \overline{(A \cap \bar{B}) \cup [(A \cap B) \cap \bar{C}]} = \overline{[(A \cap \bar{B}) \cup (A \cap B)] \cap [(A \cap \bar{B}) \cup \bar{C}]} = \overline{(A \cap B) \cup \bar{C}} = \overline{A \cup \bar{B} \cup \bar{C}}$

18.  $\bigcup_{n=1}^7 A_n = A_7 = \{1, 2, 3, 4, 5, 6, 7\}$ ,  $\bigcap_{n=1}^7 A_n = A_1 = \{1\}$ .  
 $\bigcup_{n=1}^m A_n = A_m = \{1, 2, 3, \dots, m-1, m\}$ ,  $\bigcap_{n=1}^m A_n = A_1 = \{1\}$ .

19. (a)  $[-6, 9]$       (b)  $[-8, 12]$       (c)  $\emptyset$       (d)  $[-8, -6) \cup (9, 12]$   
 (e)  $[-14, 21]$       (f)  $[-2, 3]$       (g)  $\mathbf{R}$       (h)  $[-2, 3]$

20.  $x \in \overline{\bigcap_{i \in I} A_i} \iff x \notin \bigcap_{i \in I} A_i \iff x \notin A_i$  for at least one  $i \in I \iff x \in \overline{A_i}$   
 for at least one  $i \in I \iff x \in \bigcup_{i \in I} \overline{A_i}$ .

### Section 3.3

1. Here the universe  $\mathcal{U}$  comprises the 600 freshmen. If we let  $A, B \subseteq \mathcal{U}$  be the subsets  
 $A$ : the freshmen who attended the first showing  
 $B$ : the freshmen who attended the second showing,  
then  $|\mathcal{U}| = 600$ ,  $|A| = 80$ ,  $|B| = 125$ , and  $|\overline{A \cap B}| = 450$ .  
Since  $|\overline{A \cap B}| = |\overline{A \cup B}| = 450$ , it follows that  $|A \cup B| = 600 - 450 = 150$ . Consequently,  
 $|A \cap B| = |A| + |B| - |A \cup B| = 80 + 125 - 150 = 55$  - that is, 55 of the 600 freshmen  
attended the movie twice.
2. Here the universe  $\mathcal{U}$  comprises the 2000 automobile batteries. If we let  $A, B \subseteq \mathcal{U}$  be the  
subsets  
 $A$ : the batteries with defective terminals  
 $B$ : the batteries with defective plates,  
then  $|\mathcal{U}| = 2000$ ,  $|\overline{A \cap B}| = 1920$ ,  $|B| = 60$ , and  $|A \cap B| = 20$ .  
Since  $\overline{A \cap B} = \overline{A \cup B}$ , it follows that  $|A \cup B| = 2000 - 1920 = 80$ . From  $|A \cup B| =$   
 $|A| + |B| - |A \cap B|$  we learn that  $|A| = |A \cup B| - |B| + |A \cap B| = 80 - 60 + 20 = 40$  - that  
is, 40 of her 2000 batteries have defective terminals.
3. There are  $2^9$  such strings that start with three 1's and  $2^8$  that end in four 0's. In addition,  
 $2^5$  of these strings start with three 1's and end in four 0's. Consequently, the number that  
start with three 1's or end in four 0's is

$$2^9 + 2^8 - 2^5 = 512 + 256 - 32 = 736.$$

4. (a) Here  $A \cup B \cup C = C$ , so  $|A \cup B \cup C| = |C| = 5000$ .  
(b) Here  $A \cap B \cap C = \emptyset$  as well, so it follows from the formula for  $|A \cup B \cup C| = |A| + |B| + |C| =$   
 $50 + 500 + 5000 = 5550$ .  
(c)  $|A \cup B \cup C| = |A| + |B| + |C| - |A \cap B| - |A \cap C| - |B \cap C| + |A \cap B \cap C| = 50 + 500 +$   
 $5000 - 3 - 3 - 3 + 1 = 5542$ .
5.  $9! + 9! - 8!$                       6. (a) 12                      (b) 2                      (c) 16
7. (a) There are  $24!$  permutations containing each of the patterns O U T and D I G. There  
are  $22!$  permutations containing both patterns. Consequently there are  $2(24!) - 22!$   
permutations containing either O U T or D I G.  
(b) There are  $26!$  permutations in total. Of these there are  $24!$  that contain each of the  
patterns M A N and A N T and  $23!$  that contain both patterns (i.e., contain  
M A N T). Hence there are  $2(24!) - 23!$  permutations that contain either M A N or  
A N T and  $26! - [2(24!) - 23!]$  permutations that contain neither pattern.
8. For the pattern F U N we consider four cases.  
(a) F U N . . . . Here the blanks can be filled in  $(36)^3$  ways.

- (b) \_ F U N \_ \_ . Here the blanks can be filled in  $(26)(36)^2$  ways.  
 (c) \_ \_ F U N \_ . Again there are  $26(36)^2$  ways to fill in the blanks.  
 (d) \_ \_ \_ F U N . There are also  $26(36)^2$  ways to fill in the blanks here.

Consequently the number of six character variable names containing F U N is  $(36)^3 + 3(26)(36)^2 - 1$ , because the variable F U N F U N is counted in both case (a) and case (d). There are also  $(36)^3 + 3(26)(36)^2 - 1$  of these variables that contain T I P and two that contain both F U N and T I P. Consequently, the number of these six character variables that contain either F U N or T I P is  $2[(36)^3 + 3(26)(36)^2 - 1] - 2$ .

9.

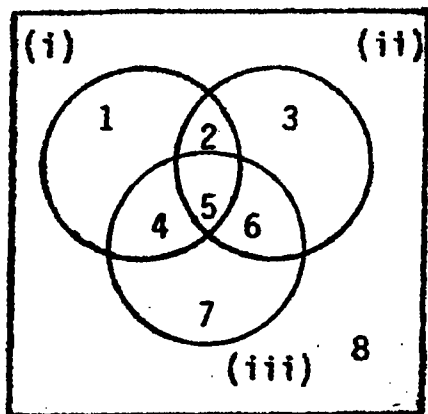

The circle labeled (i) is for the arrangements with consecutive S's; circle (ii) is for consecutive E's; and circle (iii) for consecutive L's. The answer to the problem is the number of arrangements in region 8 which we obtain as follows. For region 5 there are  $10!$  ways to arrange the 10 symbols M, I, C, A, N, O, U, S S, E E, L L. For regions 2, 4, 6 there are  $(11!/2!) - 10!$  arrangements containing exactly two pairs of consecutive letters. Finally each of regions 1, 3, 7 contains  $(12!/(2!2!)) - 2[(11!/2!) - 10!] - 10!$  arrangements, so region 8 contains  $[13!/(2!)^3] - 3[12!/(2!2!)] + 3(11!/2!) - 10!$  arrangements.

10. The number of arrangements with either H before E, or E before T, or T before M equals the total number of arrangements (i.e.,  $7!$ ) minus the number of arrangements where E is before H, and T is before E, and M is before T. There are  $3!$  ways to arrange C, I, S. For each arrangement there are four locations (one at the start, two between pairs of letters, and one at the end) to select from, with repetition, to place M, T, E, H in this prescribed order. Hence there are  $(3!)\binom{4+4-1}{4} = (3!)\binom{7}{4}$  arrangements where M is before T, T before E, and E before H. Consequently, there are  $7! - (3!)\binom{7}{4}$  arrangements with either H before E, or E before T, or T before M.

### Section 3.4

1. (a)  $Pr(A) = |A|/|S| = 3/8$   
 (b)  $Pr(B) = |B|/|S| = 4/8 = 1/2$   
 (c)  $A \cap B = \{a, c\}$  so  $Pr(A \cap B) = 2/8 = 1/4$   
 (d)  $A \cup B = \{a, b, c, e, g\}$  so  $Pr(A \cup B) = 5/8$   
 (e)  $\bar{A} = \{d, e, f, g, h\}$  and  $Pr(\bar{A}) = 5/8 = 1 - 3/8 = 1 - Pr(A)$   
 (f)  $\bar{A} \cup B = \{a, c, d, e, f, g, h\}$  with  $Pr(\bar{A} \cup B) = 7/8$   
 (g)  $A \cap \bar{B} = \{b\}$  so  $Pr(A \cap \bar{B}) = 1/8$ .
2. (a)  $S = \{(x, y) | x, y \in \{1, 2, 3, \dots, 20\}\}$   
 (b)  $S = \{(x, y) | x, y \in \{1, 2, 3, \dots, 20\}, x \neq y\}$

3. Here each equally likely outcome has probability  $\frac{1}{25} = 0.04$ . Consequently, there are  $\frac{0.24}{0.04} = 6$  outcomes in  $A$ .
4. The probability of each equally likely outcome is  $\frac{0.14}{7} = 0.02 = \frac{1}{n}$ . Therefore,  $n = \frac{1}{0.02} = 50$ .
5. (a)  $\binom{6}{2} / \binom{12}{2} = 15/66 = 5/22 = 0.2272727\dots$   
 (b)  $[\binom{1}{1}\binom{10}{1} + \binom{10}{1}\binom{1}{1}] / \binom{10}{2} = 21/66 = 7/22 = 1 - [\binom{10}{2} / \binom{12}{2}]$
6.  $S = \{\{x, y\} | x, y \in \{1, 2, 3, \dots, 99, 100\}, x \neq y\}$   
 $A = \{\{x, x+1\} | x \in \{1, 2, 3, \dots, 99\}\}$   
 $|S| = \binom{100}{2} = 4950; |A| = 99$   
 $Pr(A) = 99/4950 = 1/50$
7.  $S = \{\{x, y\} | x, y \in \{1, 2, 3, \dots, 99, 100\}, x \neq y\}$   
 $A = \{\{x, y\} | \{x, y\} \in S, x+y \text{ is even}\}$   
 $= \{\{x, y\} | \{x, y\} \in S, x, y \text{ even}\} \cup \{\{x, y\} | \{x, y\} \in S, x, y \text{ odd}\}$   
 $|S| = \binom{100}{2} = 4950; |A| = \binom{50}{2} + \binom{50}{2} = 2450$   
 $Pr(A) = 2450/4950 = 49/99$
8.  $S = \{\{a, b, c\} | a, b, c \in \{1, 2, 3, \dots, 99, 100\}, a \neq b, a \neq c, b \neq c\}$   
 $A = \{\{a, b, c\} | \{a, b, c\} \in S, a+b+c \text{ is even}\} = \{\{a, b, c\} | \{a, b, c\} \in S, a, b, c \text{ are even, or one of } a, b, c \text{ is even and the other two integers are odd}\}$   
 $|S| = \binom{100}{3} = 161,700; |A| = \binom{50}{3} + \binom{50}{1}\binom{50}{2} = 19,600 + 61,250 = 80,850$   
 $Pr(A) = 80,850/161,700 = 1/2$ .
9. The sample space  $S = \{(x_1, x_2, x_3, x_4, x_5, x_6) | x_i = H \text{ or } T, 1 \leq i \leq 6\}$ . Hence  $|S| = 2^6 = 64$ .  
 (a) Here the event  $A = \{HHHHHH\}$  and  $Pr(A) = 1/64$ .  
 (b) The event  $B = \{HHHHHT, HHHHTH, HHHHTH, HHTHHH, HHTHHH, HTHHHH, THHHHH\}$  and  $Pr(B) = 6/64 = 3/32$ .  
 (c) There are  $6!/(4!2!) = 15$  ways to arrange two heads and four tails, so the probability for this event is  $15/64$ .  
 (d) 0 heads: 1 arrangement  
 2 heads:  $[6!/(2!4!)] = 15$  arrangements  
 4 heads:  $[6!/(4!2!)] = 15$  arrangements  
 6 heads: 1 arrangement  
 The event here includes exactly 32 of the 64 arrangements in  $S$ , so the probability for an even number of heads is  $32/64 = 1/2$ .  
 (e) 4 heads:  $[6!/(4!2!)] = 15$  arrangements  
 5 heads:  $[6!/(5!1!)] = 6$  arrangements  
 6 heads: 1 arrangement  
 Here the probability is  $22/64 = 11/32$ .
10. (a)  $\binom{4}{1}\binom{20}{4} / \binom{25}{6} = (4 \cdot 4845)/177100 \doteq 0.10943$

$$(b) \binom{14}{3} \binom{10}{2} / \binom{25}{6} = (364 \cdot 45) / 177100 \doteq 0.09249$$

$$(c) \binom{4}{1} \binom{9}{1} \binom{10}{2} / \binom{25}{6} = (4 \cdot 9 \cdot 45) / 177100 \doteq 0.00915$$

11. (a) Let  $S$  = the sample space =  $\{(x_1, x_2, x_3) | 1 \leq x_i \leq 6, i = 1, 2, 3\}$ ;  $|S| = 6^3 = 216$ .

$$\text{Let } A = \{(x_1, x_2, x_3) | x_1 < x_2 \text{ and } x_1 < x_3\} = \bigcup_{n=1}^5 \{(n, x_2, x_3) | n < x_2 \text{ and } n < x_3\}.$$

$$\text{For } 1 \leq n \leq 5, |\{(n, x_2, x_3) | n < x_2 \text{ and } n < x_3\}| = (6 - n)^2.$$

$$\text{Consequently, } |A| = 5^2 + 4^2 + 3^2 + 2^2 + 1^2 = 55.$$

$$\text{Therefore, } Pr(A) = 55/216.$$

$$(b) \text{ With } S \text{ as in part (a), let } B = \{(x_1, x_2, x_3) | x_1 < x_2 < x_3\}.$$

$$\text{Then } |\{(1, x_2, x_3) | 1 < x_2 < x_3\}| = 10,$$

$$|\{(2, x_2, x_3) | 2 < x_2 < x_3\}| = 6,$$

$$|\{(3, x_2, x_3) | 3 < x_2 < x_3\}| = 3, \text{ and}$$

$$|\{(4, x_2, x_3) | 4 < x_2 < x_3\}| = 1,$$

$$\text{so } |B| = 20 \text{ and } Pr(B) = 20/216 = 5/54.$$

12. (a) 10 (b) 1 (c) 4/15
13. (a)  $\frac{14!}{15!} = \frac{1}{15}$  (b)  $[(14!) + (14!)] / (15!) = 2(14!) / (15!) = 2/15$   
(c)  $(2)(9)(13!) / (15!) = 3/35$

14. (a)  $24/300 = 0.08$   
(b) (i) There are 180 students who can program in Java. Two can be selected in  $\binom{180}{2}$  ways. The sample space consists of the  $\binom{300}{2}$  pairs of students. So the probability that two students selected at random can both program in Java is  $\binom{180}{2} / \binom{300}{2} = (180)(179) / (300)(299) \doteq 0.36$ . (ii)  $\binom{162}{2} / \binom{300}{2} \doteq 0.29$ .

15.  $Pr(A) = 1/3$ ;  $Pr(B) = 7/15$ ,  $Pr(A \cap B) = 2/15$ ;  $Pr(A \cup B) = 2/3$ .  $Pr(A \cup B) = 2/3 = (1/3) + (7/15) - (2/15) = Pr(A) + Pr(B) - Pr(A \cap B)$ .

16. (a)  $2[(5! / 2!)] / [(7! / (2!2!))] = 120 / 1260 \doteq 0.0952$   
(b)  $[(7! / (2!2!)) - 2((6! / 2!) - 5!) - 5!] / [(7! / (2!2!))] =$   
 $[(7! / (2!2!)) - 2(6! / 2!) + 5!] / [(7! / (2!2!))] =$   
 $[1260 - 720 + 120] / (1260) = 660 / 1260 \doteq 0.5238$

### Section 3.5

1.  $Pr(\bar{A}) = 1 - Pr(A) = 1 - 0.4 = 0.6$   
 $Pr(\bar{B}) = 1 - Pr(B) = 1 - 0.3 = 0.7$   
 $Pr(A \cup B) = Pr(A) + Pr(B) - Pr(A \cap B) = 0.4 + 0.3 - 0.2 = 0.5$   
 $Pr(\overline{A \cup B}) = 1 - Pr(A \cup B) = 1 - 0.5 = 0.5$   
 $Pr(A \cap \bar{B}) = Pr(A) - Pr(A \cap B)$  because  $A = (A \cap \bar{B}) \cup (A \cap B)$  with  $(A \cap \bar{B}) \cap (A \cap B) = \emptyset$ .

$$\text{So } Pr(A \cap \bar{B}) = 0.4 - 0.2 = 0.2$$

$$Pr(\bar{A} \cap B) = Pr(B) - Pr(A \cap B) = 0.3 - 0.2 = 0.1$$

$$Pr(A \cup \bar{B}) = Pr(\overline{\bar{A} \cap B}) = 1 - Pr(\bar{A} \cap B) = 1 - 0.1 = 0.9$$

$$Pr(\bar{A} \cup B) = Pr(\overline{A \cap \bar{B}}) = 1 - Pr(A \cap \bar{B}) = 1 - 0.2 = 0.8$$

$$2. (a) \binom{8}{6} \left(\frac{1}{2}\right)^6 \left(\frac{1}{2}\right)^2 = \binom{8}{6} \left(\frac{1}{2}\right)^8 \doteq 0.109375$$

$$(b) \binom{8}{6} \left(\frac{1}{2}\right)^6 \left(\frac{1}{2}\right)^2 + \binom{8}{7} \left(\frac{1}{2}\right)^7 \left(\frac{1}{2}\right) + \binom{8}{8} \left(\frac{1}{2}\right)^8 = \left(\frac{1}{2}\right)^8 [\binom{8}{6} + \binom{8}{7} + \binom{8}{8}] \doteq 0.144531$$

$$(c) \binom{8}{2} \left(\frac{1}{2}\right)^2 \left(\frac{1}{2}\right)^6 \doteq 0.109375$$

$$(d) \binom{8}{0} \left(\frac{1}{2}\right)^8 + \binom{8}{1} \left(\frac{1}{2}\right) \left(\frac{1}{2}\right)^7 + \binom{8}{2} \left(\frac{1}{2}\right)^2 \left(\frac{1}{2}\right)^6 = \left(\frac{1}{2}\right)^8 [\binom{8}{0} + \binom{8}{1} + \binom{8}{2}] \doteq 0.144531$$

$$3. (a) \mathcal{S} = \{(x, y) | x, y \in \{1, 2, 3, \dots, 10\}, x \neq y\}.$$

(b) For  $1 \leq y \leq 9$ , if  $y$  is the label on the second ball drawn, then there are  $10 - y$  possible values for  $x$  so that  $(x, y) \in \mathcal{S}$  and  $x > y$ . Consequently, if  $A$  denotes the event described here, then  $|A| = 9 + 8 + 7 + \dots + 1 = 45$  and  $Pr(A) = |A|/|\mathcal{S}| = 45/90 = 1/2$ .

(c) Let  $B = \{(v, w) | v \text{ even}, w \text{ odd}\}$ . Then we want  $Pr(B \cup C)$  where  $B \cap C = \emptyset$ . So  $Pr(B \cup C) = Pr(B) + Pr(C) = \frac{25}{90} + \frac{25}{90} = \frac{50}{90} = \frac{5}{9}$ .

$$4. \text{ Here } Pr(A) = \frac{13}{52}, Pr(B) = \frac{26}{52}, Pr(C) = \frac{12}{52}, Pr(A \cap B) = \frac{0}{52}, Pr(A \cap C) = \frac{3}{52}, Pr(B \cap C) = \frac{16}{52}, \text{ and } Pr(A \cap B \cap C) = \frac{0}{52}. \text{ So}$$

$$Pr(A \cup B \cup C) = \frac{13}{52} + \frac{26}{52} + \frac{12}{52} - \frac{0}{52} - \frac{3}{52} - \frac{6}{52} + \frac{0}{52} = \frac{42}{52} = \frac{21}{26}.$$

$$5. \text{ Since } A, B \text{ are disjoint we know that } Pr(A \cup B) = Pr(A) + Pr(B), \text{ so } Pr(B) = 0.7 - 0.3 = 0.4.$$

$$6. Pr(A \Delta B) = Pr(A) + Pr(B) - 2Pr(A \cap B)$$

$$7. (a) \text{ Let } p \text{ be the probability for the outcome 1. Then for } 1 \leq n \leq 6, \text{ the probability for the outcome } n \text{ is } np \text{ and } p + 2p + 3p + 4p + 5p + 6p = 1. \text{ Consequently } p = 1/21.$$

$$\text{So the probability for a 5 or 6 is } \frac{5}{21} + \frac{6}{21} = \frac{11}{21}.$$

$$(b) \text{ The probability the outcome is even is } \frac{2}{21} + \frac{4}{21} + \frac{6}{21} = \frac{12}{21}.$$

$$(c) 1 - \frac{12}{21} = \frac{9}{21} = \frac{1}{21} + \frac{3}{21} + \frac{5}{21}.$$

$$8. (a) \text{ Let } x \text{ be the outcome on the first die and } y \text{ the outcome on the second die. Here we want } Pr(x = 6, y = 4) + Pr(x = 5, y = 5) + Pr(x = 4, y = 6). \text{ So the probability a 10 is rolled is } \left(\frac{6}{21}\right)\left(\frac{4}{21}\right) + \left(\frac{5}{21}\right)\left(\frac{5}{21}\right) + \left(\frac{4}{21}\right)\left(\frac{6}{21}\right) = \frac{24+25+24}{441} = \frac{73}{441} \doteq 0.165533.$$

$$(b) \text{ The probability of rolling an 11 is } \left(\frac{6}{21}\right)\left(\frac{5}{21}\right) + \left(\frac{5}{21}\right)\left(\frac{6}{21}\right) = \frac{60}{441}. \text{ For 12 the probability is } \left(\frac{6}{21}\right)\left(\frac{6}{21}\right) = \frac{36}{441}. \text{ So the probability of rolling at least 10 is } \frac{73+60+36}{441} = \frac{169}{441} \doteq 0.383220.$$

$$(c) \left(\frac{1}{21}\right)^2 + \left(\frac{2}{21}\right)^2 + \dots + \left(\frac{6}{21}\right)^2 = \frac{1+4+9+16+25+36}{441} = \frac{91}{441} \doteq 0.206349.$$

$$9. \text{ Here the sample space } \mathcal{S} = \{x_1 x_2 x_3 x_4 x_5 | x_i \in \{H, T\}, 1 \leq i \leq 5\}. \text{ So } |\mathcal{S}| = 2^5 = 32. \text{ The event } A \text{ of interest here is } A = \{HHHHH, HHHHT, HHHTH, HHHTT, HHTHT, HHTHH\} \text{ and } Pr(A) = 6/32 = 3/16.$$

$$10. Pr(A) = \frac{5+60}{125} = \frac{65}{125} = \frac{13}{25} = 0.52$$

$$Pr(B) = \frac{60+30+15}{125} = \frac{105}{125} = \frac{21}{25} = 0.84$$

$$Pr(A \cap B) = \frac{60}{125} = \frac{12}{25} = 0.48$$

$$Pr(A \cup B) = Pr(A) + Pr(B) - Pr(A \cap B) = 0.52 + 0.84 - 0.48 = 0.88$$

$$Pr(\overline{A}) = 1 - Pr(A) = 0.48 \qquad Pr(\overline{B}) = 1 - Pr(B) = 0.16$$

$$Pr(\overline{A \cup B}) = Pr(\overline{A \cap B}) = 1 - Pr(A \cap B) = 0.52$$

$$Pr(\overline{A \cap B}) = Pr(\overline{A \cup B}) = 1 - Pr(A \cup B) = 0.12$$

$$Pr(A \Delta B) = Pr(A) + Pr(B) - 2Pr(A \cap B) = 0.52 + 0.84 - 2(0.48) = 0.4$$

11. (a) (i)  $\frac{18}{38} + \frac{18}{38} - \frac{9}{38} = \frac{27}{38} \doteq 0.710526$

(ii)  $\frac{18}{38} + \frac{18}{38} - \frac{9}{38} = \frac{27}{38} \doteq 0.710526$

(b) (i)  $\frac{18}{38} \cdot \frac{18}{38} = \frac{81}{361} \doteq 0.224377$

(ii)  $\frac{18}{38} \cdot \frac{2}{38} + \frac{2}{38} \cdot \frac{18}{38} = \frac{9}{361} + \frac{9}{361} = \frac{18}{361} \doteq 0.049861$

12. (i)  $Pr(A \cup B) = 1 - Pr(\overline{A \cup B}) = 1 - \frac{1}{5} = \frac{4}{5}$ .

(ii)  $Pr(A \cup B) = Pr(A) + Pr(B) - Pr(A \cap B)$ . Here  $Pr(A) = Pr(B)$ , so  $Pr(A \cup B) + Pr(A \cap B) = 2Pr(A)$ , or  $2Pr(A) = \frac{4}{5} + \frac{1}{5} = 1$ . Hence  $Pr(A) = \frac{1}{2}$ .

(iii)  $Pr(A - B) = Pr(A \cap \overline{B})$ . Since  $A = (A \cap B) \cup (A \cap \overline{B})$ , where  $(A \cap B) \cap (A \cap \overline{B}) = \emptyset$ , we have  $Pr(A - B) = Pr(A) - Pr(A \cap B) = \frac{1}{2} - \frac{1}{5} = \frac{3}{10}$ .

(iv)  $Pr(A \Delta B) = Pr(A) + Pr(B) - 2Pr(A \cap B) = \frac{1}{2} + \frac{1}{2} - 2(\frac{1}{5}) = \frac{3}{5}$ .

13.  $\frac{6}{14} + \frac{6}{14} - \frac{1}{14} = \frac{11}{14}$

14.  $[\binom{10}{5} \binom{9}{4} + \binom{10}{6} \binom{9}{3} + \binom{10}{7} \binom{9}{2} + \binom{10}{8} \binom{9}{1}] / [(\binom{19}{9} - \binom{9}{9} - \binom{10}{9})]$   
 $= [(252)(126) + (210)(84) + (120)(36) + (45)(9)] / [92378 - 1 - 10]$   
 $= (31752 + 17640 + 4320 + 405) / 92367 = 54117 / 92367 \doteq 0.585891$ .

15. (a) Ann selects her seven integers in one of  $\binom{80}{7}$  ways. Among these possible selections there are  $\binom{11}{7}$  that are winning selections. So the probability Ann is a winner is  $\binom{11}{7} / \binom{80}{7} = 330 / 3,176,716,400 \doteq 0.000000104$ . [Using a computer algebra system one gets  $0.1038808501 \times 10^{-6}$ .]

(b) The probability of having two winners is  $(0.000000104)^2 \doteq 0.1079123102 \times 10^{-13}$  - NOT very likely.

16. In general,  $B = B \cap S = B \cap (A \cup \overline{A}) = (B \cap A) \cup (B \cap \overline{A})$ . With  $A \subseteq B$  it follows that  $B = A \cup (B \cap \overline{A})$ , and since  $A \cap (B \cap \overline{A}) = B \cap (A \cap \overline{A}) = B \cap \emptyset = \emptyset$ , we have  $Pr(B) = Pr(A) + Pr(B \cap \overline{A})$ . From Axiom (1),  $Pr(A), Pr(B \cap \overline{A}) \geq 0$ , so  $Pr(B) \geq Pr(A)$ .

17. Since  $A \cup B \subseteq S$ , it follows from the result of the preceding exercise that  $Pr(A \cup B) \leq Pr(S) = 1$ . So  $1 \geq Pr(A \cup B) = Pr(A) + Pr(B) - Pr(A \cap B)$ , and  $Pr(A \cap B) \geq Pr(A) + Pr(B) - 1 = 0.7 + 0.5 - 1 = 0.2$ .

### Section 3.6

1. Let  $A, B$  be the events

$A$ : the card drawn is a king

$B$ : the card drawn is an ace or a picture card.

$$Pr(A|B) = Pr(A \cap B)/Pr(B) = \left(\frac{4}{52}\right)/\left(\frac{16}{52}\right) = \frac{4}{16} = \frac{1}{4} = 0.25.$$

- 2.

$$\begin{aligned} Pr(A \cap B) &= Pr(A) + Pr(B) - Pr(A \cup B) \\ &= 0.6 + 0.4 - 0.7 = 0.3 \end{aligned}$$

$$Pr(A|B) = Pr(A \cap B)/Pr(B) = \frac{0.3}{0.4} = \frac{3}{4} = 0.75$$

$A = A \cap (B \cup \bar{B}) = (A \cap B) \cup (A \cap \bar{B})$ , with  $(A \cap B) \cap (A \cap \bar{B}) = A \cap \emptyset = \emptyset$ , so  $Pr(A) = Pr(A \cap B) + Pr(A \cap \bar{B})$ .

Therefore,  $Pr(A \cap \bar{B}) = Pr(A) - Pr(A \cap B) = 0.6 - 0.3 = 0.3$ , and  $Pr(A|\bar{B}) = Pr(A \cap \bar{B})/Pr(\bar{B}) = 0.3/[1 - 0.4] = \frac{0.3}{0.6} = \frac{1}{2} = 0.5$ .

3. Let  $A, B$  be the events

$A$ : Coach Mollet works his football team throughout August

$B$ : The team finishes as the division champion.

Here  $Pr(B|A) = 0.75$  and  $Pr(A) = 0.80$ , so  $Pr(A \cap B) = Pr(A)Pr(B|A) = (0.80)(0.75) = 0.60$ .

4. Let  $A, B$  be the events

$A$ : a given student is taking calculus

$B$ : a given student is being introduced to a CAS.

- (a) Here we want  $Pr(B|A)$ .

$$Pr(A) = (170 + 120)/420 = 29/42$$

$$Pr(B \cap A) = 170/420 = 17/42$$

$$\text{So } Pr(B|A) = Pr(B \cap A)/Pr(A) = \left(\frac{17}{42}\right)/\left(\frac{29}{42}\right) = \frac{17}{29}.$$

- (b) In this case the answer is  $Pr(\bar{A}|\bar{B})$ .

$$Pr(\bar{B}) = 1 - Pr(B) = 1 - [(170 + 80)/420] = 1 - \frac{25}{42} = \frac{17}{42}$$

$$Pr(\bar{A} \cap \bar{B}) = \frac{50}{420} = \frac{5}{42}$$

$$\text{So } Pr(\bar{A}|\bar{B}) = Pr(\bar{A} \cap \bar{B})/Pr(\bar{B}) = \left(\frac{5}{42}\right)/\left(\frac{17}{42}\right) = \frac{5}{17}.$$

5. In general,  $Pr(A \cup B) = Pr(A) + Pr(B) - Pr(A \cap B)$ . Since  $A, B$  are independent,  $Pr(A \cap B) = Pr(A)Pr(B)$ . So

$$\begin{aligned} Pr(A \cup B) &= Pr(A) + Pr(B) - Pr(A)Pr(B) \\ &= Pr(A) + [1 - Pr(A)]Pr(B) \\ &= Pr(A) + Pr(\bar{A})Pr(B). \end{aligned}$$

The proof for  $Pr(B) + Pr(\bar{B})Pr(A)$  is similar.

6. Let  $A, B$  denote the events

$A$ : first toss is a head

$B$ : three heads are obtained in five tosses.

(a)  $Pr(B|A) = Pr(B \cap A)/Pr(A) = \binom{4}{2}(\frac{1}{2})^4/(\frac{1}{2}) = \frac{6}{8} = \frac{3}{4}$ . [For the event  $B \cap A$  we consider the number of ways we can place two Hs and two Ts in the last four positions. This is  $\binom{4}{2}$ .]

(b)  $Pr(B|\bar{A}) = Pr(B \cap \bar{A})/Pr(\bar{A}) = \binom{4}{3}(\frac{1}{2})^4/(\frac{1}{2}) = \frac{4}{8} = \frac{1}{2}$ .

7. Let  $A, B$  denote the events

$A$ : Bruno selects a gold coin

$B$ : Madeleine selects a gold coin

$$\begin{aligned} \text{(a) } Pr(B) &= Pr(B \cap A) + Pr(B \cap \bar{A}) \\ &= Pr(A)Pr(B|A) + Pr(\bar{A})Pr(B|\bar{A}) \\ &= \left(\frac{6}{15}\right)\left(\frac{11}{17}\right) + \left(\frac{9}{15}\right)\left(\frac{10}{17}\right) = \frac{66+90}{255} = \frac{156}{255} = \frac{52}{85} \end{aligned}$$

$$\begin{aligned} \text{(b) } Pr(A|B) &= \frac{Pr(A \cap B)}{Pr(B)} = \frac{Pr(A)Pr(B|A)}{Pr(B)} \\ &= \left[\left(\frac{6}{15}\right)\left(\frac{11}{17}\right)\right] / \left(\frac{52}{85}\right) = \frac{66}{156} = \frac{11}{26}. \end{aligned}$$

8.  $A = \{TH, TT\}$ ,  $Pr(A) = \binom{1}{3}\binom{2}{3} + \binom{1}{3}^2 = \frac{2}{9} + \frac{1}{9} = \frac{3}{9} = \frac{1}{3}$

$B = \{TT, HH\}$ ,  $Pr(B) = \binom{1}{3}^2 + \binom{2}{3}^2 = \frac{1}{9} + \frac{4}{9} = \frac{5}{9}$

$A \cap B = \{TT\}$ ,  $Pr(A \cap B) = \binom{1}{3}^2 = \frac{1}{9}$

$Pr(A \cap B) = \frac{1}{9} = \frac{2}{81} \neq \frac{15}{81} = \left(\frac{3}{9}\right)\left(\frac{5}{9}\right) = Pr(A)Pr(B)$ , so  $A, B$  are *not* independent.

9. 
$$\begin{aligned} Pr(A \cup B) &= Pr(A) + Pr(B) - Pr(A \cap B) \\ &= Pr(A) + Pr(B) - Pr(A)Pr(B), \end{aligned}$$

because  $A, B$  are independent.

$$0.6 = 0.3 + Pr(B) - (0.3)Pr(B)$$

$$0.3 = 0.7Pr(B)$$

So  $Pr(B) = \frac{3}{7}$ .

10. (a) Let  $A, B$  denote the events

$A$ : Alice gets four heads (and three tails)

$B$ : Alice's first toss is a head.

$$Pr(A|B) = Pr(A \cap B)/Pr(B) = \frac{[(\frac{1}{2})\binom{6}{3}(\frac{1}{2})^3(\frac{1}{2})^3]}{(\frac{1}{2})} = \binom{6}{3}\left(\frac{1}{2}\right)^6 = \frac{20}{64} = \frac{5}{16} \doteq 0.3125.$$

(b) Let  $A, C$  denote the events

$A$ : Alice gets four heads (and three tails)

$C$ : Alice's first and last tosses are heads.

$$Pr(A|C) = Pr(A \cap C)/Pr(C) = \frac{[(\frac{1}{2})\binom{5}{3}(\frac{1}{2})^2(\frac{1}{2})^3(\frac{1}{2})]}{(\frac{1}{2})(\frac{1}{2})} = \binom{5}{3}\left(\frac{1}{2}\right)^5 = \frac{10}{32} = \frac{5}{16} \doteq 0.3125.$$

$$\begin{aligned} Pr(A) &= \binom{5}{1}\left(\frac{1}{2}\right)^1\left(\frac{1}{2}\right)^4 + \binom{5}{3}\left(\frac{1}{2}\right)^3\left(\frac{1}{2}\right)^2 + \binom{5}{5}\left(\frac{1}{2}\right)^5 \\ &= \left(\frac{1}{2}\right)^5[5 + 10 + 1] = \frac{16}{32} = \frac{1}{2} \end{aligned}$$

$$\begin{aligned} 11. \quad Pr(B) &= \frac{1}{2} \\ Pr(A \cap B) &= \left(\frac{1}{2}\right)\left[\binom{4}{0}\left(\frac{1}{2}\right)^4 + \binom{4}{2}\left(\frac{1}{2}\right)^2\left(\frac{1}{2}\right)^2 + \binom{4}{4}\left(\frac{1}{2}\right)^4\right] \\ &= \left(\frac{1}{2}\right)\left(\frac{1}{2}\right)^4[1 + 6 + 1] = \frac{8}{32} = \frac{1}{4} \end{aligned}$$

Since  $Pr(A \cap B) = \frac{1}{4} = \left(\frac{1}{2}\right)\left(\frac{1}{2}\right) = Pr(A)Pr(B)$ , the events  $A, B$  are independent.

$$12. \quad (0.95)(0.98) = 0.931$$

13. Let  $A, B$  be the events

$A$ : Paul initially selects a can of lemonade

$B$ : Betty selects two cans of cola.

$$Pr(A|B) = \frac{Pr(A \cap B)}{Pr(B)} = \frac{Pr(A)Pr(B|A)}{Pr(B)}$$

$$Pr(A) = \frac{3}{11}$$

$$Pr(B) = Pr(A)Pr(B|A) + Pr(\bar{A})Pr(B|\bar{A})$$

$$= \left(\frac{3}{11}\right)\left(\frac{5}{13}\right)\left(\frac{4}{12}\right) + \left(\frac{8}{11}\right)\left(\frac{6}{13}\right)\left(\frac{5}{12}\right)$$

$$\text{So } Pr(A|B) = \frac{\left(\frac{3}{11}\right)\left(\frac{5}{13}\right)\left(\frac{4}{12}\right)}{\left(\frac{3}{11}\right)\left(\frac{5}{13}\right)\left(\frac{4}{12}\right) + \left(\frac{8}{11}\right)\left(\frac{6}{13}\right)\left(\frac{5}{12}\right)} = \frac{60}{60+240} = \frac{6}{30} = \frac{1}{5}.$$

$$14. \quad Pr(A \cup B \cup C) = Pr(A) + Pr(B) + Pr(C) - Pr(A \cap B) - Pr(A \cap C) - Pr(B \cap C) + Pr(A \cap B \cap C) = Pr(A) + Pr(B) + Pr(C) - Pr(A)Pr(B) - 0 - Pr(B)Pr(C) + 0.$$

Note:  $A, C$  disjoint  $\Rightarrow A \cap C = \emptyset \Rightarrow A \cap B \cap C = \emptyset \Rightarrow Pr(A \cap B \cap C) = 0$ .

$$0.8 = 0.2 + Pr(B) + 0.4 - 0.2Pr(B) - 0.4Pr(B)$$

$$0.2 = 0.4Pr(B)$$

$$\text{So } Pr(B) = \frac{1}{2} = 0.5$$

15. Let  $A, B$  denote the events

$A$ : the first component fails

$B$ : the second component fails.

Here  $Pr(A) = 0.05$  and  $Pr(B|A) = 0.02$ . The probability the electronic system fails is

$$Pr(A \cap B) = Pr(A)Pr(B|A) = (0.05)(0.02) = 0.001.$$

16. Let  $R, B, W$  denote the withdrawal of a red, blue, and white marble, respectively. Here we are interested in the following cases (with their corresponding probabilities).

$$RRR: \quad Pr(RRR) = \left(\frac{9}{19}\right)\left(\frac{8}{18}\right)\left(\frac{7}{17}\right)$$

$$RRB, RBR, BRR: \quad Pr(RRB) = \left(\frac{9}{19}\right)\left(\frac{8}{18}\right)\left(\frac{6}{17}\right) [= Pr(RBR) = Pr(BRR)]$$

$$RRW, RWR, WRR: \quad Pr(RRW) = \left(\frac{9}{19}\right)\left(\frac{8}{18}\right)\left(\frac{4}{17}\right) [= Pr(RWR) = Pr(WRR)]$$

$$RBB, BRB, BBR: \quad Pr(RBB) = \left(\frac{9}{19}\right)\left(\frac{6}{18}\right)\left(\frac{5}{17}\right) [= Pr(BRB) = Pr(BBR)]$$

Consequently, the probability Gayla has withdrawn more red than white marbles is

$$\frac{(9)(8)(7) + 3(9)(8)(6) + 3(9)(8)(4) + 3(9)(6)(5)}{(19)(18)(17)} = \frac{3474}{5814} = \frac{193}{323} \doteq 0.597523.$$

17. In general,  $Pr(A \cup B \cup C) = Pr(A) + Pr(B) + Pr(C) - Pr(A \cap B) - Pr(A \cap C) - Pr(B \cap C) + Pr(A \cap B \cap C)$ . Since  $A, B, C$  are independent we have

$$\frac{1}{2} = Pr(A \cup B \cup C) = Pr(A) + Pr(B) + Pr(C) - Pr(A)Pr(B) - Pr(A)Pr(C) - Pr(B)Pr(C) + Pr(A)Pr(B)Pr(C) = \left(\frac{1}{8}\right) + \left(\frac{1}{4}\right) + Pr(C) - \left(\frac{1}{8}\right)\left(\frac{1}{4}\right) - \left(\frac{1}{8}\right)Pr(C) - \left(\frac{1}{4}\right)Pr(C) + \left(\frac{1}{8}\right)\left(\frac{1}{4}\right)Pr(C).$$

Consequently,  $\frac{1}{2} - \frac{1}{8} - \frac{1}{4} + \frac{1}{32} = \left[1 - \frac{1}{8} - \frac{1}{4} + \frac{1}{32}\right]Pr(C)$  and  $Pr(C) = \frac{5}{21}$ .

18. Let  $A, B, C, D$  denote the following events

$A$ : the graphics card comes from the first source

$B$ : the graphics card comes from the second source

$C$ : the graphics card comes from the third source

$D$ : the graphics card is defective.

Then

$$Pr(A) = 0.2, Pr(B) = 0.35, Pr(C) = 0.45$$

$$Pr(D|A) = 0.05, Pr(D|B) = 0.03, Pr(D|C) = 0.02$$

$$(a) Pr(D) = Pr(D \cap A) + Pr(D \cap B) + Pr(D \cap C) = Pr(A)Pr(D|A) + Pr(B)Pr(D|B) + Pr(C)Pr(D|C) = (0.2)(0.05) + (0.35)(0.03) + (0.45)(0.02) = 0.0295.$$

So 2.95% of the company's graphics card are defective.

$$(b) Pr(C|D) = \frac{Pr(C \cap D)}{Pr(D)} = \frac{Pr(C)Pr(D|C)}{Pr(D)} = [(0.45)(0.02)] / (0.0295) = 18/59 \doteq 0.305085$$

19. Here  $A = \{HH, HT\}$  and  $Pr(A) = \frac{1}{2}$ ;  $B = \{HT, TT\}$  with  $Pr(B) = \frac{1}{2}$ ; and  $C = \{HT, TH\}$  with  $Pr(C) = \frac{1}{2}$ .

Also  $A \cap B = \{HT\}$ , so  $Pr(A \cap B) = \frac{1}{4} = \left(\frac{1}{2}\right)\left(\frac{1}{2}\right) = Pr(A)Pr(B)$ ;  $A \cap C = \{HT\}$ , so  $Pr(A \cap C) = \frac{1}{4} = \left(\frac{1}{2}\right)\left(\frac{1}{2}\right) = Pr(A)Pr(C)$ ; and  $B \cap C = \{HT\}$  with  $Pr(B \cap C) = \left(\frac{1}{4}\right) = \left(\frac{1}{2}\right)\left(\frac{1}{2}\right) = Pr(B)Pr(C)$ . Consequently, any two of the events  $A, B, C$  are independent.

However,  $A \cap B \cap C = \{HT\}$  so  $Pr(A \cap B \cap C) = \frac{1}{4} \neq \frac{1}{8} = \left(\frac{1}{2}\right)\left(\frac{1}{2}\right)\left(\frac{1}{2}\right) = Pr(A)Pr(B)Pr(C)$ . Consequently, the events  $A, B, C$  are *not* independent.

20.  $(0.75)(0.85)(0.9) + (0.75)(0.85)(0.1) + (0.75)(0.15)(0.9) + (0.25)(0.85)(0.9) = 0.57375 + 0.06375 + 0.10125 + 0.19125 = 0.93$ .

21. (a) For  $0 \leq k \leq 3$ , the probability of tossing  $k$  heads in three tosses is  $\binom{3}{k}\left(\frac{1}{2}\right)^k\left(\frac{1}{2}\right)^{3-k} = \binom{3}{k}\left(\frac{1}{2}\right)^3$ . The probability Dustin and Jennifer each toss the same number of heads is  $\sum_{k=0}^3 \left[\binom{3}{k}\left(\frac{1}{2}\right)^3\right]^2 = \left(\frac{1}{2}\right)^6 \left[\binom{3}{0}^2 + \binom{3}{1}^2 + \binom{3}{2}^2 + \binom{3}{3}^2\right] = \left(\frac{1}{2}\right)^6 [1 + 9 + 9 + 1] = \frac{20}{64} = \frac{5}{16} \doteq 0.3125$ .

(b) Let  $x$  count the number of heads in Dustin's three tosses and  $y$  the number in Jennifer's. Here we consider the cases where  $x = 3: y = 2, 1, \text{ or } 0$ ;  $x = 2: y = 1 \text{ or } 0$ ;  $x = 1: y = 0$ . The probability that Dustin gets more heads than Jennifer is  $\binom{3}{3}\left(\frac{1}{2}\right)^3 \left[\binom{3}{2}\left(\frac{1}{2}\right)^2\left(\frac{1}{2}\right) + \binom{3}{1}\left(\frac{1}{2}\right)\left(\frac{1}{2}\right)^2 + \binom{3}{0}\left(\frac{1}{2}\right)^3\right] + \binom{3}{2}\left(\frac{1}{2}\right)^2\left(\frac{1}{2}\right) \left[\binom{3}{1}\left(\frac{1}{2}\right)\left(\frac{1}{2}\right)^2 + \binom{3}{0}\left(\frac{1}{2}\right)^3\right] + \binom{3}{1}\left(\frac{1}{2}\right)\left(\frac{1}{2}\right)^2 \left[\binom{3}{0}\left(\frac{1}{2}\right)^3\right] = \left(\frac{1}{2}\right)^6 [3 + 3 + 1] + \left(\frac{1}{2}\right)^6 (3)[3 + 1] + \left(\frac{1}{2}\right)^6 (3)(1) = \left(\frac{1}{2}\right)^6 (22) = \frac{11}{32}$ .

(c) Here the answer is likewise  $\frac{11}{32}$ .

[Note: The answers in parts (a), (b), and (c) sum to 1 because the union of the three events for these parts is the entire sample space and the events are disjoint in pairs. Consequently, upon recognizing how the answers in parts (b), (c) are related we see that the answer to part (b) is  $\left(\frac{1}{2}\right)\left[1 - \frac{5}{16}\right] = \left(\frac{1}{2}\right)\left(\frac{11}{16}\right) = \frac{11}{32}$ .]

22. We need the (equal) probabilities for the disjoint events: (1) One cousin gets a head and

the other four get tails; (2) One cousin gets a tail and the other four get heads.

The probability for event (1) is  $(5)(\frac{1}{2})^5 = \frac{5}{32}$ . So the answer is  $\frac{5}{32} + \frac{5}{32} = \frac{5}{16}$ .

23. Let  $A, B$  denote the following events:

$A$ : A new airport-security employee has had prior training in weapon detection

$B$ : A new airport-security employee fails to detect a weapon during the first month on the job.

Here  $Pr(A) = 0.9$ ,  $Pr(\bar{A}) = 0.1$ ,  $Pr(B|\bar{A}) = 0.03$  and  $Pr(B|A) = 0.005$ .

The probability a new airport-security employee, who fails to detect a weapon during the first month on the job, has had prior training in weapon detection =  $Pr(A|B) = \frac{Pr(A \cap B)}{Pr(B)}$  =

$$\frac{Pr(A)Pr(B|A)}{Pr(B \cap A) + Pr(B \cap \bar{A})} = \frac{Pr(A)Pr(B|A)}{Pr(A)Pr(B|A) + Pr(\bar{A})Pr(B|\bar{A})} = (0.9)(0.005)/[(0.9)(0.005) + (0.1)(0.03)] = 0.0045/[0.0045 + 0.003] = \frac{45}{75} = \frac{3}{5} = 0.6.$$

24. Let  $A, B, C$  denote the events

$A$ : the binary string is a palindrome

$B$ : the first and sixth bits of the string are 1

$C$ : the first and sixth bits of the string are the same

(a)  $Pr(A|B) = Pr(A \cap B)/Pr(B)$

$Pr(B) = (\frac{1}{2})(1)(1)(1)(1)(\frac{1}{2}) = \frac{1}{4}$ , where each 1 is the probability that a given position (second, third, fourth, or fifth) is filled with a 0 or 1.

$Pr(A \cap B) = (\frac{1}{2})(1)(1)(\frac{1}{2})(\frac{1}{2})(\frac{1}{2}) = \frac{1}{16}$ , where, for example, the first 1 is the probability that the second position is filled with a 0 or 1, and the third  $\frac{1}{2}$  is the probability that the bit in the fifth position matches the bit in the second position.

$$Pr(A|B) = Pr(A \cap B)/Pr(B) = (\frac{1}{16})/(\frac{1}{4}) = \frac{1}{4}$$

(b)  $Pr(A|C) = Pr(A \cap C)/Pr(C)$

$$Pr(C) = (\frac{1}{2})(1)(1)(1)(1)(\frac{1}{2}) + (\frac{1}{2})(1)(1)(1)(1)(\frac{1}{2}),$$

for the two disjoint events where the binary strings start and end with 0, or start and end with 1.

$$Pr(A \cap C) = (1)(1)(1)(\frac{1}{2})(\frac{1}{2})(\frac{1}{2}) + (1)(1)(1)(\frac{1}{2})(\frac{1}{2})(\frac{1}{2})$$

$$Pr(A|C) = [\frac{1}{8} + \frac{1}{8}]/[\frac{1}{4} + \frac{1}{4}] = (\frac{1}{4})/(\frac{1}{2}) = \frac{1}{2}.$$

25. (a) There are  $\binom{5}{2} = 10$  conditions – one for each pair of events;  $\binom{5}{3} = 10$  conditions – one for each triple of events;  $\binom{5}{4} = 5$  conditions – one for each quadruple of events; and  $\binom{5}{5} = 1$  condition for all five of the events. In total there are 26 [=  $2^5 - \binom{5}{0} - \binom{5}{1}$ ] conditions to be checked.

(b)  $2^n - \binom{n}{0} - \binom{n}{1} = 2^n - 1 - n = 2^n - (n + 1)$  conditions must be checked to establish the independence of  $n$  events.

26. Since  $0.3 = Pr(\bar{A} \cap \bar{B}) = Pr(\overline{A \cup B})$ , it follows that  $Pr(A \cup B) = 1 - 0.3 = 0.7$ .

$$\Pr(A\Delta B|A\cup B) = \frac{\Pr((A\Delta B)\cap(A\cup B))}{\Pr(A\cup B)} = \Pr(A\Delta B)/\Pr(A\cup B) = \\ [\Pr(A\cup B) - \Pr(A\cap B)]/\Pr(A\cup B) = (0.7 - 0.1)/(0.7) = 0.6/0.7 = 6/7.$$

27. Let  $B_0, B_1, B_2, B_3$ , and denote  $A$  denote the events

$B_i$ : for the three envelopes randomly selected from urn 1 and transferred to urn 2,  $i$  envelopes each contain \$1 while the other  $3-i$  envelopes each contain \$5, where  $0 \leq i \leq 3$ .

$A$ : Carmen's selection from urn 2 is an envelope that contains \$1.

$$\text{Here, } \Pr(A) = \Pr(A\cap B_0) + \Pr(A\cap B_1) + \Pr(A\cap B_2) + \Pr(A\cap B_3) \\ = \Pr(B_0)\Pr(A|B_0) + \Pr(B_1)\Pr(A|B_1) + \Pr(B_2)\Pr(A|B_2) + \Pr(B_3)\Pr(A|B_3) \\ = \left[\binom{6}{0}\binom{8}{3}/\binom{14}{3}\right]\left(\frac{3}{11}\right) + \left[\binom{6}{1}\binom{8}{2}/\binom{14}{3}\right]\left(\frac{4}{11}\right) + \left[\binom{6}{2}\binom{8}{1}/\binom{14}{3}\right]\left(\frac{5}{11}\right) + \left[\binom{6}{3}\binom{8}{0}/\binom{14}{3}\right]\left(\frac{6}{11}\right) = \\ \left(\frac{2}{13}\right)\left(\frac{3}{11}\right) + \left(\frac{6}{13}\right)\left(\frac{4}{11}\right) + \left(\frac{30}{91}\right)\left(\frac{5}{11}\right) + \left(\frac{5}{91}\right)\left(\frac{6}{11}\right) = \\ \left(\frac{1}{91}\right)\left(\frac{1}{11}\right)[42 + 168 + 150 + 30] = 390/1001 = 30/77.$$

28.  $\Pr(B|A) < \Pr(B) \Rightarrow \Pr(B\cap A)/\Pr(A) < \Pr(B) \Rightarrow \Pr(B\cap A) < \Pr(A)\Pr(B)$ .

Consequently,  $\Pr(A\cap B) = \Pr(B\cap A) < \Pr(A)\Pr(B)$ , so  $\Pr(A|B) = \Pr(A\cap B)/\Pr(B) < \Pr(A)$ .

29.  $0.8 = \Pr(A|B) + \Pr(B|A) = \frac{\Pr(A\cap B)}{\Pr(B)} + \frac{\Pr(B\cap A)}{\Pr(A)} = \Pr(A\cap B)[(1/0.3) + (1/0.5)]$ , so  $(0.15)(0.8) = \Pr(A\cap B)[0.5 + 0.3] = (0.8)\Pr(A\cap B)$ . Consequently,  $\Pr(A\cap B) = 0.15$ .

30.  $\Pr(A\cup B) - \Pr(A\Delta B) = \Pr(A\cap B) = 0.7 - 0.5 = 0.2$ . Since  $0.5 = \Pr(A|B) = \Pr(A\cap B)/\Pr(B)$ , it follows that  $\Pr(B) = \Pr(A\cap B)/0.5 = 0.2/0.5 = 0.4$ .

$0.7 = \Pr(A\cup B) = \Pr(A) + \Pr(B) - \Pr(A\cap B) = \Pr(A) + 0.4 - 0.2$ , so  $\Pr(A) = 0.5$ .

### Section 3.7

1. (a)  $\Pr(X = 3) = \frac{1}{4}$   
 (b)  $\Pr(X \leq 4) = \sum_{x=0}^4 \Pr(X = x) = \frac{1}{8} + \frac{1}{4} + \frac{1}{4} + \frac{1}{4} + \frac{1}{8} = 1$   
 (c)  $\Pr(X > 0) = \sum_{x=1}^4 \Pr(X = x) = \frac{1}{4} + \frac{1}{4} + \frac{1}{4} + \frac{1}{8} = \frac{7}{8}$   
 (d)  $\Pr(1 \leq X \leq 3) = \sum_{x=1}^3 \Pr(X = x) = \frac{1}{4} + \frac{1}{4} + \frac{1}{4} = \frac{3}{4}$   
 (e)  $\Pr(X = 2|X \leq 3) = \frac{\Pr(X = 2 \text{ and } X \leq 3)}{\Pr(X \leq 3)} = \frac{\Pr(X = 2)}{\Pr(X \leq 3)} = \left(\frac{1}{4}\right)/\left[\frac{1}{8} + \frac{1}{4} + \frac{1}{4} + \frac{1}{4}\right] =$

$$\left(\frac{1}{4}\right)/\left(\frac{7}{8}\right) = \left(\frac{1}{4}\right)\left(\frac{8}{7}\right) = \frac{2}{7}$$

(f)  $\Pr(X \leq 1 \text{ or } X = 4) = \Pr(X = 0) + \Pr(X = 1) + \Pr(X = 4) = \frac{1}{8} + \frac{1}{4} + \frac{1}{8} = \frac{1}{2}$

2. (a)  $\Pr(X = 3) = \frac{3(3)+1}{22} = \frac{10}{22} = \frac{5}{11}$   
 (b)  $\Pr(X \leq 1) = \Pr(X = 0) + \Pr(X = 1) = \frac{3(0)+1}{22} + \frac{3(1)+1}{22} = \frac{1}{22} + \frac{4}{22} = \frac{5}{22}$   
 (c)  $\Pr(1 \leq X < 3) = \Pr(X = 1) + \Pr(X = 2) = \frac{3(1)+1}{22} + \frac{3(2)+1}{22} = \frac{4}{22} + \frac{7}{22} = \frac{11}{22} = \frac{1}{2}$   
 (d)  $\Pr(X > -2) = \sum_{x=0}^3 \Pr(X = x) = \frac{3(0)+1}{22} + \frac{3(1)+1}{22} + \frac{3(2)+1}{22} + \frac{3(3)+1}{22} = \frac{1+4+7+10}{22} = \frac{22}{22} = 1$   
 (e)  $\Pr(X = 1|X \leq 2) = \frac{\Pr(X = 1 \text{ and } X \leq 2)}{\Pr(X \leq 2)} = \frac{\Pr(X = 1)}{\Pr(X \leq 2)} = \left[\frac{3(1)+1}{22}\right]/\left[\frac{3(0)+1}{22} + \frac{3(1)+1}{22}\right]$

$$\frac{3(1) + 1}{22} + \frac{3(2) + 1}{22} = \left(\frac{4}{22}\right) / \left(\frac{12}{22}\right) = \frac{4}{12} = \frac{1}{3}.$$

3. (a)  $Pr(X = x) = \frac{\binom{10}{x} \binom{110}{5-x}}{\binom{120}{5}}, x = 0, 1, 2, \dots, 5.$

(b)  $Pr(X = 4) = \frac{\binom{10}{4} \binom{110}{1}}{\binom{120}{5}} = \frac{(210)(110)}{190,578,024} = \frac{23,100}{190,578,024} = \frac{275}{2,268,786} \doteq 0.000121$

(c)  $Pr(X \geq 4) = Pr(X = 4) + Pr(X = 5) = \frac{\binom{10}{4} \binom{110}{1}}{\binom{120}{5}} + \frac{\binom{10}{5} \binom{110}{0}}{\binom{120}{5}} = \frac{23,100 + 252}{190,578,024} = \frac{23,352}{190,578,024} = \frac{139}{1,134,393} \doteq 0.000123.$

(d)  $Pr(X = 1 | X \leq 2) = \frac{Pr(X = 1 \text{ and } X \leq 2)}{Pr(X \leq 2)} = \frac{Pr(X = 1)}{Pr(X \leq 2)}$

$$\begin{aligned} &= \frac{\binom{10}{1} \binom{110}{4} / \binom{120}{5}}{\left[ \frac{\binom{10}{0} \binom{110}{5}}{\binom{120}{5}} + \frac{\binom{10}{1} \binom{110}{4}}{\binom{120}{5}} + \frac{\binom{10}{2} \binom{110}{3}}{\binom{120}{5}} \right]} \\ &= \frac{\binom{10}{1} \binom{110}{4}}{\left[ \binom{10}{0} \binom{110}{5} + \binom{10}{1} \binom{110}{4} + \binom{10}{2} \binom{110}{3} \right]} \\ &= (10)(5,773,185) / [(1)(122,391,522) + (10)(5,773,185) + (45)(215,820)] \\ &= 57,731,850 / [122,391,522 + 57,731,850 + 9,711,900] \\ &= 57,731,850 / 189,835,272 = 2675 / 8796 \doteq 0.304116. \end{aligned}$$

(a)  $X_1: Pr(X_1 = x_1) = \binom{3}{x_1} \left(\frac{1}{2}\right)^{x_1} \left(\frac{1}{2}\right)^{3-x_1} = \binom{3}{x_1} \left(\frac{1}{2}\right)^3, x_1 = 0, 1, 2, 3.$

$X_2: Pr(X_2 = x_2) = \binom{3}{x_2} \left(\frac{1}{2}\right)^{x_2} \left(\frac{1}{2}\right)^{3-x_2} = \binom{3}{x_2} \left(\frac{1}{2}\right)^3, x_2 = 0, 1, 2, 3.$

4.  $X: Pr(X = -3) = Pr(X_1 = 0)Pr(X_2 = 3 | X_1 = 0) = \binom{3}{0} \left(\frac{1}{2}\right)^3 (1) = \left(\frac{1}{2}\right)^3$

$Pr(X = -1) = Pr(X_1 = 1)Pr(X_2 = 2 | X_1 = 1) = \binom{3}{1} \left(\frac{1}{2}\right)^3 (1) = (3) \left(\frac{1}{2}\right)^3$

$Pr(X = 1) = Pr(X_1 = 2)Pr(X_2 = 1 | X_1 = 2) = \binom{3}{2} \left(\frac{1}{2}\right)^3 (1) = (3) \left(\frac{1}{2}\right)^3$

$Pr(X = 3) = Pr(X_1 = 3)Pr(X_2 = 0 | X_1 = 3) = \binom{3}{3} \left(\frac{1}{2}\right)^3 (1) = \left(\frac{1}{2}\right)^3$

(b)  $E(X_1) = \sum_{x_1=0}^3 x_1 Pr(X_1 = x_1) = 0 \cdot \binom{3}{0} \left(\frac{1}{2}\right)^3 + 1 \cdot \binom{3}{1} \left(\frac{1}{2}\right)^3 + 2 \cdot \binom{3}{2} \left(\frac{1}{2}\right)^3 + 3 \cdot \binom{3}{3} \left(\frac{1}{2}\right)^3 = 0 + \frac{3}{8} + \frac{6}{8} + \frac{3}{8} = \frac{12}{8} = \frac{3}{2} = 3 \left(\frac{1}{2}\right) = np$ , since  $X_1$  is binomial with  $n = 3$  and  $p = \frac{1}{2}$ .

$E(X_2) = \frac{3}{2}$

$E(X) = (-3) \left(\frac{1}{2}\right)^3 + (-1) (3) \left(\frac{1}{2}\right)^3 + (1) (3) \left(\frac{1}{2}\right)^3 + 3 \left(\frac{1}{2}\right)^3 = 0 = [E(X_1) - E(X_2)].$

5. (a)  $Pr(X \geq 3) = \sum_{x=3}^6 Pr(X = x) = Pr(X = 3) + Pr(X = 4) + Pr(X = 5) + Pr(X = 6) = \frac{1}{6} + \frac{1}{6} + \frac{1}{6} + \frac{1}{6} = \frac{4}{6} = \frac{2}{3}$

(b)  $Pr(2 \leq X \leq 5) = \sum_{x=2}^5 Pr(X = x) = Pr(X = 2) + Pr(X = 3) + Pr(X = 4) + Pr(X = 5) = \frac{1}{6} + \frac{1}{6} + \frac{1}{6} + \frac{1}{6} = \frac{4}{6} = \frac{2}{3}$

(c)  $Pr(X = 4 | X \geq 3) = \frac{Pr(X = 4 \text{ and } X \geq 3)}{Pr(X \geq 3)} = \frac{Pr(X = 4)}{Pr(X \geq 3)} = (1/6) / (4/6) = 1/4.$

(d)  $E(X) = \sum_{x=1}^6 x Pr(X = x) = \sum_{x=1}^6 x \cdot \left(\frac{1}{6}\right) = \left(\frac{1}{6}\right)(1 + 2 + 3 + 4 + 5 + 6) = \left(\frac{1}{6}\right)(21) = 7/2.$

(e)  $E(X^2) = \sum_{x=1}^6 x^2 Pr(X = x) = \left(\frac{1}{6}\right)(1 + 4 + 9 + 16 + 25 + 36) = \left(\frac{1}{6}\right)(91) = \frac{91}{6}$

$$\begin{aligned} \text{Var}(X) &= E(X^2) - E(X)^2 \\ &= \left(\frac{91}{6}\right) - \left(\frac{7}{2}\right)^2 = \frac{91}{6} - \frac{49}{4} = \frac{182 - 147}{12} = \frac{35}{12} \end{aligned}$$

6. (a)  $1 = c \sum_{x=1}^5 \frac{x^2}{x!} = c \left(1 + \frac{4}{2} + \frac{9}{6} + \frac{16}{24} + \frac{25}{120}\right) = c \left(\frac{24 + 48 + 36 + 16 + 5}{24}\right) = c \left(\frac{129}{24}\right) = c \left(\frac{43}{8}\right)$ , so  $c = \frac{8}{43}$ .

$$(b) Pr(X \geq 3) = Pr(X = 3) + Pr(X = 4) + Pr(X = 5) = c\left(\frac{8}{6} + \frac{16}{24} + \frac{25}{120}\right) = \left(\frac{8}{43}\right)\left(\frac{57}{24}\right) = \frac{19}{43}.$$

$$(c) Pr(X = 4|X \geq 3) = \frac{Pr(X = 4 \text{ and } X \geq 3)}{Pr(X \geq 3)} = \frac{Pr(X = 4)}{Pr(X \geq 3)} = \left(\frac{8}{43}\right)\left(\frac{16}{24}\right) / \left(\frac{19}{43}\right) = \frac{16}{57}.$$

$$(d) E(X) = \sum_{x=1}^5 x \cdot Pr(X = x) = \left(\frac{8}{43}\right) \sum_{x=1}^5 x \cdot \frac{x^2}{x!}$$

$$= \left(\frac{8}{43}\right) \sum_{x=1}^5 \frac{x^3}{x!} = \left(\frac{8}{43}\right) \left[1 + \frac{8}{2} + \frac{27}{6} + \frac{64}{24} + \frac{125}{120}\right]$$

$$= \left(\frac{8}{43}\right)\left(\frac{317}{24}\right) = \frac{317}{129} \doteq 2.457364$$

$$(e) E(X^2) = \left(\frac{8}{43}\right) \sum_{x=1}^5 \frac{x^4}{x!} = \left(\frac{8}{43}\right) \left[1 + \frac{16}{2} + \frac{81}{6} + \frac{256}{24} + \frac{625}{120}\right] = \left(\frac{8}{43}\right)\left(\frac{921}{24}\right) = \frac{307}{43}$$

$$\text{Var}(X) = E(X^2) - E(X)^2 = \frac{307}{43} - \left(\frac{317}{129}\right)^2 = \frac{18320}{16641} \doteq 1.100895.$$

7. (a)  $1 = \sum_{x=1}^5 Pr(X = x) = c \sum_{x=1}^5 (6 - x) = c(5 + 4 + 3 + 2 + 1) = 15c$ , so  $c = 1/15$ .

(b)  $Pr(X \leq 2) = Pr(X = 1) + Pr(X = 2) = \left(\frac{1}{15}\right)(6 - 1) + \left(\frac{1}{15}\right)(6 - 2) = \frac{9}{15} = \frac{3}{5}$

(c)  $E(X) = \sum_{x=1}^5 x \cdot Pr(X = x) = \sum_{x=1}^5 x \cdot \left(\frac{1}{15}\right)(6 - x)$   
 $= \left(\frac{1}{15}\right)[1 \cdot 5 + 2 \cdot 4 + 3 \cdot 3 + 4 \cdot 2 + 5 \cdot 1] = \left(\frac{1}{15}\right)(35) = \frac{7}{3}$

(d)  $E(X^2) = \sum_{x=1}^5 x^2 \cdot \left(\frac{1}{15}\right)(6 - x) =$   
 $\left(\frac{1}{15}\right)[1 \cdot 5 + 4 \cdot 4 + 9 \cdot 3 + 16 \cdot 2 + 25 \cdot 1] = \left(\frac{1}{15}\right)(105) = 7$

$\text{Var}(X) = E(X^2) - E(X)^2 = 7 - \left(\frac{7}{3}\right)^2 = \frac{63 - 49}{9} = \frac{14}{9}$

8. Let the random variable  $X$  count the number of heads in the 100 tosses. Assuming that the tosses are independent, this random variable is binomial with  $n = 100$  and  $p = \frac{3}{4}$ . So Wayne should expect to see  $E(X) = np = 100\left(\frac{3}{4}\right) = 75$  heads among the results of his 100 tosses.

9. Since  $X$  is binomial,  $E(X) = 70 = np$  and  $\text{Var}(X) = 45.5 = npq$ . Hence, we find that  $45.5 = 70q$ , so  $q = 45.5/70 = 0.65$ . Consequently, it follows that  $p = 0.35$  and  $n = 70/p = 70/0.35 = 200$ .

10. Let the random variable  $X$  denote the player's net winnings and let  $C$  denote the cost of playing one round of this carnival game. The probability distribution for  $X$  is as follows:

$x$	$Pr(X = x)$
$5 - C$	$\frac{8}{52} = \frac{2}{13}$
$8 - C$	$\frac{8}{52} = \frac{2}{13}$
$-C$	$\frac{36}{52} = \frac{9}{13}$

Here  $0 = E(X) = \frac{2}{13}(5 - C) + \frac{2}{13}(8 - C) + \frac{9}{13}(-C) = \frac{10}{13} + \frac{16}{13} - C$  and  $C = \frac{26}{13} = 2$ . So the game is fair if the player pays two dollars to play each round.

11. Here  $X$  is binomial with  $n = 8$  and  $p = 0.25$ .

(a)  $Pr(X = 0) = \binom{8}{0}(0.25)^0(0.75)^8 \doteq 0.100113$

(b)  $Pr(X = 3) = \binom{8}{3}(0.25)^3(0.75)^5 \doteq 0.207642$

(c)  $Pr(X \geq 6) = Pr(X = 6) + Pr(X = 7) + Pr(X = 8) = \binom{8}{6}(0.25)^6(0.75)^2 + \binom{8}{7}(0.25)^7(0.75)^1 + \binom{8}{8}(0.25)^8(0.75)^0 \doteq 0.004227.$

(d)  $Pr(X \geq 6|X \geq 4) = \frac{Pr(X \geq 6 \text{ and } X \geq 4)}{Pr(X \geq 4)} = \frac{Pr(X \geq 6)}{Pr(X \geq 4)}$

$$\Pr(X \geq 4) = \sum_{x=4}^8 \binom{8}{x} (0.25)^x (0.75)^{8-x} = \binom{8}{4} (0.25)^4 (0.75)^4 + \binom{8}{5} (0.25)^5 (0.75)^3 + \binom{8}{6} (0.25)^6 (0.75)^2 + \binom{8}{7} (0.25)^7 (0.75)^1 + \binom{8}{8} (0.25)^8 (0.75)^0 \doteq 0.113815$$

$$\text{So } \Pr(X \geq 6 | X \geq 4) \doteq 0.004227 / 0.113815 \doteq 0.037139.$$

$$(e) E(X) = np = 8(0.25) = 2.$$

$$(f) \text{Var}(X) = np(1-p) = 8(0.25)(0.75) = 1.5$$

12. Here  $\sigma_X = \sqrt{9} = 3$ .

$$(a) \Pr(11 \leq X \leq 23) = \Pr(11 - 17 \leq X - 17 \leq 23 - 17) = \Pr(-6 \leq X - 17 \leq 6)$$

$$= \Pr(|X - 17| \leq 6) = \Pr(|X - E(X)| \leq 2\sigma_X) \geq 1 - \frac{1}{2^2} = 1 - \frac{1}{4} = \frac{3}{4}$$

$$(b) \Pr(10 \leq X \leq 24) = \Pr(|X - 17| \leq 7) = \Pr(|X - E(X)| \leq (\frac{7}{3})\sigma_X) \geq 1 - 1/(\frac{7}{3})^2 = 1 - \frac{9}{49} = \frac{40}{49}$$

$$(c) \Pr(8 \leq X \leq 26) = \Pr(|X - 17| \leq 9) = \Pr(|X - E(X)| \leq 3\sigma_X) \geq 1 - \frac{1}{3^2} = 1 - \frac{1}{9} = \frac{8}{9}$$

13. In Chebyshev's Inequality  $\Pr(|X - E(X)| \leq k\sigma_X) \geq 1 - \frac{1}{k^2}$ . If  $1 - \frac{1}{k^2} = 0.96$ , then  $1 - 0.96 = 0.04 = \frac{1}{k^2}$ , and  $k^2 = \frac{1}{0.04}$ . Since  $k > 0$  we have  $k = \frac{1}{0.2} = 5$ .

$$\text{Here } \text{Var}(X) = 4 \text{ so } \sigma_X = 2 \text{ and } c = k\sigma_X = 5 \cdot 2 = 10.$$

14. Here  $X$  is binomial with  $n = 20$  and  $p = 1/6$ . So  $E(X) = np = (20)(\frac{1}{6}) = \frac{20}{6} = \frac{10}{3}$  and  $\text{Var}(X) = np(1-p) = (20)(\frac{1}{6})(\frac{5}{6}) = \frac{25}{9}$ .

15. Let  $D$  denote a defective chip and  $G$  a good one. Then the sample space  $S = \{D, GD, GGD, GGG\}$  and  $X(D) = 1$ ,  $X(GD) = 2$ , and  $X(GGD) = X(GGG) = 3$ .

$$(a) \Pr(X = 1) = \frac{4}{20} = \frac{1}{5}$$

$$\Pr(X = 2) = \binom{16}{20} \binom{4}{19} = \frac{16}{95}$$

$$\Pr(X = 3) = \binom{16}{20} \binom{15}{19} \binom{4}{18} + \binom{16}{20} \binom{15}{19} \binom{14}{18} = \frac{12}{19}$$

$$(b) \Pr(X \leq 2) = \Pr(X = 1) + \Pr(X = 2) = \frac{1}{5} + \frac{16}{95} = \frac{35}{95} = \frac{7}{19}$$

$$(c) \Pr(X = 1 | X \leq 2) = \frac{\Pr(X = 1 \text{ and } X \leq 2)}{\Pr(X \leq 2)} = \frac{\Pr(X = 1)}{\Pr(X \leq 2)} = \left(\frac{1}{5}\right) / \left(\frac{7}{19}\right) = \frac{19}{35}$$

$$(d) E(X) = \sum_{x=1}^3 x \Pr(X = x) = 1\left(\frac{1}{5}\right) + 2\left(\frac{16}{95}\right) + 3\left(\frac{12}{19}\right) = \frac{1}{5} + \frac{32}{95} + \frac{36}{19} = \frac{19+32+180}{95} = \frac{231}{95} = 2.431579$$

$$(e) E(X^2) = \sum_{x=1}^3 x^2 \Pr(X = x) = 1\left(\frac{1}{5}\right) + 4\left(\frac{16}{95}\right) + 9\left(\frac{12}{19}\right) = \frac{1}{5} + \frac{64}{95} + \frac{108}{19} = \frac{19+64+540}{95} = \frac{623}{95}$$

$$\text{Var}(X) = E(X^2) - E(X)^2 = \frac{623}{95} - \left(\frac{231}{95}\right)^2 = \frac{5824}{(95)^2} = \frac{5824}{9025} \doteq 0.645319$$

16. (a)  $E(aX + b) = \sum_x (ax + b) \Pr(X = x) = a \sum_x x \Pr(X = x) + b \sum_x \Pr(X = x) = aE(X) + b$ , since  $\sum_x \Pr(X = x) = 1$ .

$$(b) \text{Var}(aX + b) = \sum_x [(ax + b) - E(aX + b)]^2 \Pr(X = x) = \sum_x [(ax + b) - (aE(X) + b)]^2 \Pr(X = x) \text{ [from part (a)]} = \sum_x (ax - aE(X))^2 \Pr(X = x) = a^2 \sum_x (x - E(X))^2 \Pr(X = x) = a^2 \text{Var}(X)$$

$$17. (a) E(X(X-1)) = \sum_{x=0}^n x(x-1) \Pr(X = x) = \sum_{x=2}^n x(x-1) \Pr(X = x) = \sum_{x=2}^n x(x-1) \binom{n}{x} p^x q^{n-x} = \sum_{x=2}^n \frac{n!}{x!(n-x)!} x(x-1) p^x q^{n-x}$$

$$\begin{aligned}
&= \sum_{x=2}^n \frac{n!}{(x-2)!(n-x)!} p^x q^{n-x} = p^2 n(n-1) \sum_{x=2}^n \frac{(n-2)!}{(x-2)!(n-x)!} p^{x-2} q^{n-x} \\
&= p^2 n(n-1) \sum_{y=0}^{n-2} \frac{(n-2)!}{y!(n-(y+2))!} p^y q^{n-(y+2)}, \text{ substituting } x-2=y, \\
&= p^2 n(n-1) \sum_{y=0}^{n-2} \frac{(n-2)!}{y!(n-2-y)!} p^y q^{(n-2)-y} \\
&= p^2 n(n-1)(p+q)^{n-2}, \text{ by the Binomial Theorem} \\
&= p^2 n(n-1)(1)^{n-2} = p^2 n(n-1) = n^2 p^2 - np^2
\end{aligned}$$

$$\text{(b) } \text{Var}(X) = E(X^2) - E(X)^2 = [E(X(X-1)) + E(X)] - E(X)^2 = [(n^2 p^2 - np^2) + np] - (np)^2 = n^2 p^2 - np^2 + np - n^2 p^2 = np - np^2 = np(1-p) = npq.$$

18. (a)  $\Pr(X > 1) = \Pr(X = 2) + \Pr(X = 3) + \Pr(X = 4) = 0.3 + 0.2 + 0.1 = 0.6 = 1 - 0.4 = 1 - \Pr(X \leq 1)$

(b)  $\Pr(X = 3 | X \geq 2) = \frac{\Pr(X = 3 \text{ and } X \geq 2)}{\Pr(X \geq 2)} = \Pr(X = 3) / \Pr(X \geq 2) =$

$$\Pr(X = 3) / [\Pr(X = 2) + \Pr(X = 3) + \Pr(X = 4)] = 0.2 / 0.6 = 1/3$$

(c)  $E(X) = \sum_{x=1}^4 x \Pr(X = x) = 1(0.4) + 2(0.3) + 3(0.2) + 4(0.1) = 2$

(d)  $E(X^2) = \sum_{x=1}^4 x^2 \Pr(X = x) = 1^2(0.4) + 2^2(0.3) + 3^2(0.2) + 4^2(0.1) = 5$

$$\text{Var}(X) = E(X^2) - E(X)^2 = 5 - 2^2 = 5 - 4 = 1$$

(a) Word	$x$ , the number of letters and apostrophes in the word
I'll	4
make	4
him	3
an	2
offer	5
he	2
can't	5
refuse	6

19.

$x$	$\Pr(X = x)$
2	$2/8 = 1/4$
3	$1/8$
4	$2/8 = 1/4$
5	$2/8 = 1/4$
6	$1/8$

(b)  $E(X) = \sum_{x=2}^6 x \cdot \Pr(X = x)$   
 $= 2(1/4) + 3(1/8) + 4(1/4) + 5(1/4) + 6(1/8)$   
 $= (1/8)[4 + 3 + 8 + 10 + 6] = 31/8$

(c)  $E(X^2) = \sum_{x=2}^6 x^2 \cdot \Pr(X = x)$   
 $= 4(1/4) + 9(1/8) + 16(1/4) + 25(1/4) + 36(1/8)$   
 $= (1/8)[8 + 9 + 32 + 50 + 36] = 135/8$

$$\text{Var}(X) = E(X^2) - E(X)^2 = (135/8) - (31/8)^2 = [1080 - 961]/64 = 119/64$$

20. (a)  $\Pr(X = 0) = (0.05)(0.1)(0.12) = 0.0006$

$$\Pr(X = 1) = (0.95)(0.1)(0.12) + (0.05)(0.9)(0.12) + (0.05)(0.1)(0.88) = 0.0114 + 0.0054 + 0.0044 = 0.0212$$

$$Pr(X = 2) = (0.95)(0.9)(0.12) + (0.95)(0.1)(0.88) + (0.05)(0.9)(0.88) = 0.1026 + 0.0836 + 0.0396 = 0.2258$$

$$Pr(X = 3) = (0.95)(0.9)(0.88) = 0.7524$$

[Note that  $\sum_{x=0}^3 Pr(X = x) = 0.0006 + 0.0212 + 0.2258 + 0.7524 = 1.$ ]

$$(b) Pr(X \geq 2 | X \geq 1) = \frac{Pr(X \geq 2 \text{ and } X \geq 1)}{Pr(X \geq 1)} = Pr(X \geq 2) / Pr(X \geq 1) = [0.2258 + 0.7524] / [0.0212 + 0.2258 + 0.7524] = 0.9782 / 0.9994 = 0.978787272$$

$$(c) E(X) = \sum_{x=0}^3 x \cdot Pr(X = x) = 0(0.0006) + 1(0.0212) + 2(0.2258) + 3(0.7524) = 2.73.$$

$$(d) E(X^2) = \sum_{x=0}^3 x^2 \cdot Pr(X = x) = 0^2(0.0006) + 1^2(0.0212) + 2^2(0.2258) + 3^2(0.7524) = 7.696$$

$$Var(X) = E(X^2) - E(X)^2 = 7.696 - (2.73)^2 = 0.2431.$$

$$21. Pr(X = 2) = \left[ \binom{1}{1} \binom{1}{1} \right] / \binom{5}{2} = 1/10 \quad Pr(X = 3) = \left[ \binom{2}{1} \binom{1}{1} \right] / \binom{5}{2} = 2/10$$

$$Pr(X = 4) = \left[ \binom{3}{1} \binom{1}{1} \right] / \binom{5}{2} = 3/10 \quad Pr(X = 5) = \left[ \binom{4}{1} \binom{1}{1} \right] / \binom{5}{2} = 4/10$$

$$E(X) = (1/10)(2) + (2/10)(3) + (3/10)(4) + (4/10)(5) = (1/10)[2 + 6 + 12 + 20] = 40/10 = 4$$

$$E(X^2) = (1/10)(4) + (2/10)(9) + (3/10)(16) + (4/10)(25) = (1/10)[4 + 18 + 48 + 100] = 170/10 = 17$$

$$Var(X) = E(X^2) - E(X)^2 = 17 - 16 = 1, \text{ so } \sigma_X = \sqrt{1} = 1.$$

### Supplementary Exercises

1. Suppose that  $(A - B) \subseteq C$  and  $x \in A - C$ . Then  $x \in A$  but  $x \notin C$ . If  $x \notin B$ , then  $[x \in A \wedge x \notin B] \implies x \in (A - B) \subseteq C$ . So now we have  $x \notin C$  and  $x \in C$ . This contradiction gives us  $x \in B$ , so  $(A - C) \subseteq B$ .

Conversely, if  $(A - C) \subseteq B$ , let  $y \in A - B$ . Then  $y \in A$  but  $y \notin B$ . If  $y \notin C$ , then  $[y \in A \wedge y \notin C] \implies y \in (A - C) \subseteq B$ . This contradiction, i.e.,  $y \notin B$  and  $y \in B$ , yields  $y \in C$ , so  $(A - B) \subseteq C$ .

2. Let  $S = \{x, y, a_1, a_2, \dots, a_n\}$ . There are  $\binom{n+2}{r}$  subsets of  $S$  containing  $r$  elements, where  $r \geq 2$ . These subsets fall into three categories. (a) Neither  $x$  nor  $y$  is in the subset. There are  $\binom{n}{r}$  of these. (b) Exactly one of  $x$  and  $y$  is in the subset. These account for  $2\binom{n}{r-1}$  subsets. (c) Both  $x$  and  $y$  are in the subset. There are  $\binom{n}{r-2}$  such subsets.

3. (a)  $U = \{1, 2, 3\}$ ,  $A = \{1, 2\}$ ,  $B = \{1\}$ ,  $C = \{2\}$  provide a counterexample.  
 (b)  $A = A \cap U = A \cap (C \cup \overline{C}) = (A \cap C) \cup (A \cap \overline{C}) = (A \cap C) \cup (A - C) = (B \cap C) \cup (B - C) = (B \cap C) \cup (B \cap \overline{C}) = B \cap (C \cup \overline{C}) = B \cap U = B$   
 (c) The set assignments for part (a) also provide a counterexample for this situation.

4. (a) Consider  $m + n$  objects denoted by  $\{x_1, x_2, \dots, x_m\} \cup \{y_1, y_2, \dots, y_n\}$ . Let  $A = \{x_1, \dots, x_m\}$ ,  $B = \{y_1, \dots, y_n\}$ . In selecting  $r$  elements from  $A \cup B$  we select  $k$  elements from  $A$  ( $0 \leq k \leq m$ ), and  $(r - k)$  elements from  $B$  ( $0 \leq r - k \leq n$ ). Consequently, the number of subsets of  $A \cup B$  with  $r$  elements is  $\binom{m+n}{r} = \binom{m}{0} \binom{n}{r} + \binom{m}{1} \binom{n}{r-1} + \dots + \binom{m}{r} \binom{n}{0} =$

$$\sum_{k=0}^r \binom{m}{k} \binom{n}{r-k}.$$

(b) Replace  $m$  by  $n$  and  $r$  by  $n$  in part (a), and use the fact that  $\binom{n}{k} \binom{n}{n-k} = \binom{n}{k}^2$ .

5. (a) 126 (if teams wear different uniforms); 63 (if teams are not distinguishable).  
 (b)  $2^n - 2$ ;  $(1/2)(2^n - 2)$ .  $2^n - 2 - 2n$ ;  $(1/2)(2^n - 2 - 2n)$ .
6. (a) False: Let  $A = \{0, 1, 2, 3, \dots\}$ ,  $B = \{0, -1, -2, \dots\}$ . Then  $A, B$  are infinite but  $|A \cap B| = |\{0\}| = 1$   
 (b) False: Let  $A = \{1, 2\}$  and  $B = \mathbb{Z}^+$ .  
 (c) True  
 (d) False: Let  $A = \{1, 2\}$  and  $B = \mathbb{Z}^+$ .

7. (a) 128 (b)  $|A| = 8$

8. (a)  $2^7$  (b)  $\binom{8}{3}(2^7)$  (c)  $\binom{8}{3}\binom{7}{5}$

```
(d) 10 Random
    20 Dim S(8)
    30 For I = 1 To 8
    40     S(I) = Int(Rnd * 15) + 1
    50     For J = 1 To I - 1
    60         If S(I) = S(J) Then GOTO 40
    70     Next J
    80 Next I
    90 C = 0
    100 Rem C counts the odd elements of the subset
    110 For I = 1 To 8
    120     If (S(I)/2) <> Int (S(I)/2) Then C = C + 1
    130 Next I
    140 Print "The eight-element subset generated ";
    150 Print "in this program contains the elements"
    160 For I = 1 To 7
    170     Print S(I); ",";
    180 Next I
    190 Print " and "; S(8); ", and "; C;
    200 Print " of these elements are odd"
    210 End
```

9. Suppose that  $(A \cap B) \cup C = A \cap (B \cup C)$  and that  $x \in C$ . Then  $x \in C \implies x \in (A \cap B) \cup C \implies x \in A \cap (B \cup C) \subseteq A$ , so  $x \in A$ , and  $C \subseteq A$ .  
 Conversely, suppose that  $C \subseteq A$ .

(1) If  $y \in (A \cap B) \cup C$ , then  $y \in A \cap B$  or  $y \in C$ . (i)  $y \in A \cap B \implies y \in (A \cap B) \cup (A \cap C) \implies y \in A \cap (B \cup C)$ . (ii)  $y \in C \implies y \in A$ , since  $C \subseteq A$ . Also,  $y \in C \implies y \in B \cup C$ . So  $y \in A \cap (B \cup C)$ . In either case ((i) or (ii)) we have  $y \in A \cap (B \cup C)$ , so  $(A \cap B) \cup C \subseteq A \cap (B \cup C)$ .

(2) Now let  $z \in A \cap (B \cup C)$ . Then  $z \in A \cap (B \cup C) = (A \cap B) \cup (A \cap C) \subseteq (A \cap B) \cup C$ . From (1) and (2) it follows that  $(A \cap B) \cup C = A \cap (B \cup C)$ .

10. (a) Here  $|A \cup B| - |A \cap B| = 5$ , so there are  $2^5$  subsets  $C$  where  $A \cap B \subseteq C \subseteq A \cup B$ . The number containing an even number of elements is  $\binom{5}{1}$  (for  $|C| = 4$ ) +  $\binom{5}{3}$  (for  $|C| = 6$ ) +  $\binom{5}{5}$  (for  $|C| = 8$ ) = 16.

(b)  $2^5$ ;  $\binom{5}{0} + \binom{5}{2} + \binom{5}{4} = 16$ .

11. (a)  $[0, 14/3]$  (b)  $\{0\} \cup (6, 12]$  (c)  $[0, +\infty)$  (d)  $\emptyset$

12. (a)  $A \Delta B = (A - B) \cup (B - A) = (B - A) \cup (A - B) = B \Delta A$

(b)  $A \Delta \bar{A} = (A - \bar{A}) \cup (\bar{A} - A) = A \cup \bar{A} = \mathcal{U}$

(c)  $A \Delta \mathcal{U} = (A - \mathcal{U}) \cup (\mathcal{U} - A) = \emptyset \cup \bar{A} = \bar{A}$

(d)  $A \Delta \emptyset = (A - \emptyset) \cup (\emptyset - A) = A \cup \emptyset = A$

13.

(a)	A	B	$A \cap B$
→	0	0	0
→	0	1	0
→	1	0	0
→	1	1	1

Since  $A \subseteq B$ , we only consider rows 1, 2, and 4 of the table. In these rows  $A$  and  $A \cap B$  have the same column of results, so  $A \subseteq B \implies A = A \cap B$ .

(c)	A	B	C	$A \cap \bar{C}$	$A \cap \bar{B}$	$B \cap \bar{C}$	$(A \cap \bar{B}) \cup (B \cap \bar{C})$
→	0	0	0	0	0	0	0
→	0	0	1	0	0	0	0
→	0	1	0	0	0	1	1
→	0	1	1	0	0	0	0
→	1	0	0	1	1	0	1
→	1	0	1	0	1	0	1
→	1	1	0	1	0	1	1
→	1	1	1	0	0	0	0

We consider only rows 1, 5, 7, and 8. There  $A \cap \bar{C} = (A \cap \bar{B}) \cup (B \cap \bar{C})$ .

(b) & (d) The results for these parts are derived in a similar manner.

14. (a)  $B \subseteq A \implies A \cup B = A$ .

(b)  $(A \cup B = A)$  and  $(B \cap C = C) \implies A \cap B \cap C = C$ .

(c)  $C \supseteq B \supseteq A \implies (A \cup \bar{B}) \cap (B \cup \bar{C}) = A \cup \bar{C}$ .

(d)  $(A \cup \bar{B}) \cap (B \cup \bar{A}) = C \implies (A \cup \bar{C}) \cap (C \cup \bar{A}) = B$  and  $(B \cup \bar{C}) \cap (C \cup \bar{B}) = A$ .

15. (a) The  $r$  0's determine  $r+1$  locations for the  $m$  individual 1's. If  $r+1 \geq m$ , we can select these locations in  $\binom{r+1}{m}$  ways.  
 (b) Using part (a), here we have  $k$  1's (for the elements of  $A$ ) and  $n-k$  0's (for the elements in  $\mathcal{U} - A$ ). The  $n-k$  0's provide  $n-k+1$  locations for the  $k$  1's so that no two are adjacent. These  $k$  locations can be selected in  $\binom{n-k+1}{k}$  ways if  $n-k+1 \geq k$  or  $2k \leq n+1$ . So there are  $\binom{n-k+1}{k}$  subsets  $A$  of  $\mathcal{U}$  with  $|A| = k$  and such that  $A$  contains no consecutive integers.

16. 2/7

17. (a) 23 (b) 8

18. 7

19.

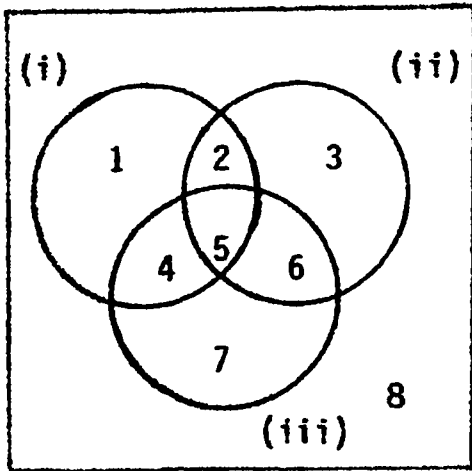

For the given figure let circles (i), (ii), and (iii) denote the subset of assignments where no one is working on experiments 1,2,3, respectively. For each assistant there are seven possibilities: the seven nonempty subsets of  $\{1,2,3\}$ . So there are  $7^{15}$  possible assignments. To determine the number of assignments in region 8 we need to determine the number of assignments in the union of the three subsets. Region 5 has 0 elements, while regions 2,4,6 each contain 1 element (e.g., for region 2, if all assistants are assigned only to experiment 3 then this is the one way that everyone is working on an experiment, but no one is working on experiments 1 and 2).

In each of regions 1,3,7 there are  $3^{15} - 2$  elements (e.g., for regions 1,2,4,5 there are 3 cases to consider where no one is working on experiment 1 - for each assistant can be working on only experiment 2 or only experiment 3 or both experiments 2,3). The number of assignments where at least one person is working on every experiment is  $7^{15} - 3[3^{15} - 2] - 3$ .

20.

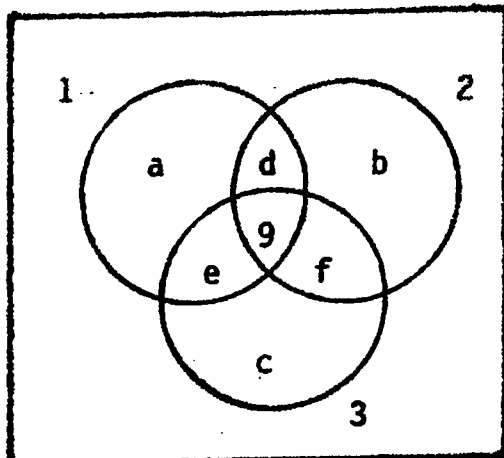

Consider the Venn diagram shown on the left. From the information given we know that

- (i)  $a + b + c + d + e + f = 21 - 9 = 12$ ;
- (ii)  $b + c + f = 5$ ;
- (iii)  $a + c + e = 7$ ; and
- (iv)  $a + b + d = 6$ .

Adding equations (ii), (iii) and (iv) we find that  $2(a + b + c) + (d + e + f) = 18$ , so  $12 = (a + b + c) + [18 - 2(a + b + c)]$ , and the number of students who answered exactly one question is  $a + b + c = 6$ .

21. Since  $|A \cap B| = 0$ ,  $|A \cup B| = 12 + 10 = 22$ . There are  $\binom{22}{7}$  ways to select seven elements from  $A \cup B$ . Among these selections  $\binom{12}{4} \binom{10}{3}$  contain four elements from  $A$  and three from  $B$ . Consequently, the probability sought here is  $\binom{12}{4} \binom{10}{3} / \binom{22}{7} = (495)(120) / (170,544) \doteq 0.3483$ .

22. (a)  $\mathcal{P}(\mathcal{U}) = \{0, \{1\}, \{2\}, \{3\}, \{1, 2\}, \{1, 3\}, \{2, 3\}, \mathcal{U}\}$  and  $\sum_{A \in \mathcal{P}(\mathcal{U})} \sigma(A) = 1 + 2 + 3 + (1 + 2) + (1 + 3) + (2 + 3) + (1 + 2 + 3) = 4(1 + 2 + 3) = 2^2(1 + 2 + 3) = 24$ .

(b)  $2^3(1 + 2 + 3 + 4) = 80$

(c)  $2^4(1 + 2 + 3 + 4 + 5) = 240$

(d)  $2^{n-1}(1 + 2 + 3 + \dots + n)$

Proof (1): Let  $x \in \mathcal{U}$ . Then  $x$  appears in 1 subset by itself,  $\binom{n-1}{1}$  subsets of size 2,  $\binom{n-1}{2}$  subsets of size 3, ...,  $\binom{n-1}{k-1}$  subsets of size  $k$ , ..., and  $\binom{n-1}{n-1}$  subsets of size  $n$ .

Hence  $x$  appears in a total of  $[\binom{n-1}{0} + \binom{n-1}{1} + \binom{n-1}{2} + \dots + \binom{n-1}{n-1}] = 2^{n-1}$  subsets. So  $\sum_{A \in \mathcal{P}(\mathcal{U})} \sigma(A) = 2^{n-1} \sum_{x \in \mathcal{U}} x = 2^{n-1}(1 + 2 + 3 + \dots + n)$ .

Proof (2): Let  $x \in \mathcal{U}$ . For each subset  $A \subseteq \mathcal{U}$ , if  $x \notin A$  then  $x \in \bar{A}$ . Hence for each pair  $(A, \bar{A})$  of subsets of  $\mathcal{U}$ , exactly one of them contains  $x$ . How many such pairs are there?  $(1/2)(2^n) = 2^{n-1}$ . Consequently, each  $x \in \mathcal{U}$  can be found in exactly  $2^{n-1}$  subsets of  $\mathcal{U}$  and the result for  $\sum_{A \in \mathcal{P}(\mathcal{U})} \sigma(A)$  follows.

(e) Using the result from part (d) it follows that  $\sum_{A \in \mathcal{P}(\mathcal{U})} \sigma(A) = 2^{n-1}s$ .

23. (a)

$\underbrace{\binom{16}{8}}$	+	$\underbrace{\binom{14}{7} \binom{15}{1}}$	+	$\underbrace{\binom{12}{6} \binom{13+2-1}{2}}$
no diagonal moves		one diagonal move		two diagonal moves
$+ \underbrace{\binom{10}{5} \binom{11+3-1}{3}}$	+	$\underbrace{\binom{8}{4} \binom{9+4-1}{4}}$	+	$\underbrace{\binom{6}{3} \binom{7+5-1}{5}}$
three diagonal moves		four diagonal moves		five diagonal moves
$+ \underbrace{\binom{4}{2} \binom{5+6-1}{6}}$	+	$\underbrace{\binom{2}{1} \binom{3+7-1}{7}}$	+	$\underbrace{\binom{0}{0} \binom{1+8-1}{8}}$
six diagonal moves		seven diagonal moves		eight diagonal moves

$$= \sum_{i=0}^8 \binom{2i}{i} \binom{(2i+1) + (8-i) - 1}{8-i} = \sum_{i=0}^8 \binom{2i}{i} \binom{8+i}{8-i}$$

(b) (i)  $\binom{12}{6} \binom{14}{2} / \sum_{i=0}^8 \binom{2i}{i} \binom{8+i}{8-i}$   
(ii)  $\binom{12}{6} \binom{13}{1} / \sum_{i=0}^8 \binom{2i}{i} \binom{8+i}{8-i}$   
(iii)  $[\binom{16}{8} + \binom{12}{6} \binom{14}{2} + \binom{8}{4} \binom{12}{4} + \binom{4}{2} \binom{10}{6} + \binom{0}{0} \binom{8}{8}] / \sum_{i=0}^8 \binom{2i}{i} \binom{8+i}{8-i}$

24.  $x^2 - 7x = -12 \Rightarrow x^2 - 7x + 12 = 0 \Rightarrow (x-4)(x-3) = 0 \Rightarrow x = 4, x = 3.$   
 $x^2 - x = 6 \Rightarrow x^2 - x - 6 = 0 \Rightarrow (x-3)(x+2) = 0 \Rightarrow x = 3, x = -2.$   
Consequently,  $A \cap B = \{3\}$  and  $A \cup B = \{-2, 3, 4\}.$

25.  $x^2 - 7x \leq -12 \Rightarrow x^2 - 7x + 12 \leq 0 \Rightarrow (x-3)(x-4) \leq 0 \Rightarrow [(x-3) \leq 0 \text{ and } (x-4) \geq 0]$   
or  $[(x-3) \geq 0 \text{ and } (x-4) \leq 0] \Rightarrow [x \leq 3 \text{ and } x \geq 4]$  or  $[x \geq 3 \text{ and } x \leq 4] \Rightarrow 3 \leq x \leq 4,$   
so  $A = \{x | 3 \leq x \leq 4\} = [3, 4].$

$x^2 - x \leq 6 \Rightarrow x^2 - x - 6 \leq 0 \Rightarrow (x-3)(x+2) \leq 0 \Rightarrow [(x-3) \leq 0 \text{ and } (x+2) \geq 0]$  or  
 $[(x-3) \geq 0 \text{ and } (x+2) \leq 0] \Rightarrow [x \leq 3 \text{ and } x \geq -2]$  or  $[x \geq 3 \text{ and } x \geq -2] \Rightarrow -2 \leq x \leq 3,$   
so  $B = \{x | -2 \leq x \leq 3\} = [-2, 3].$

Consequently,  $A \cap B = \{3\}$  and  $A \cup B = [-2, 4].$

26. The probability that all four of these torpedoes fail to destroy the enemy ship is  
 $(1-0.75)(1-0.80)(1-0.85)(1-0.90) = (0.25)(0.20)(0.15)(0.10) = 0.00075.$  Consequently,  
the probability the enemy ship is destroyed is  $1 - 0.00075 = 0.99925.$

27. There are two cases to consider.

(1) The one tail is obtained on the fair coin. The probability for this is  $\binom{2}{1} \left(\frac{1}{2}\right) \left(\frac{1}{2}\right) \left(\frac{4}{4}\right) \left(\frac{3}{4}\right)^4.$

(2) The one tail is obtained on the biased coin. The probability in this case is  $\binom{2}{2} \left(\frac{1}{2}\right)^2 \left(\frac{4}{3}\right) \left(\frac{3}{4}\right)^3 \left(\frac{1}{4}\right)$

Consequently, the answer is the sum of these two probabilities – namely,  $\frac{81}{512} + \frac{108}{1024} = \frac{136}{512} \doteq 0.263672$ .

28. Let  $S$  be the sample space for an experiment  $\mathcal{E}$ , with events  $A, B \subseteq S$ . Prove that  $Pr(A|B) \geq \frac{Pr(A)+Pr(B)-1}{Pr(B)}$ .

Proof:  $P(A|B) = Pr(A \cap B)/Pr(B) = [Pr(A) + Pr(B) - Pr(A \cup B)]/Pr(B)$ . Since  $A \cup B \subseteq S$ , it follows that  $Pr(A \cup B) \leq Pr(S) = 1$ . Consequently,  $-Pr(A \cup B) \geq -1$  and  $Pr(A|B) \geq [Pr(A) + Pr(B) - 1]/Pr(B)$ .

29.  $Pr(A \cap (B \cup C)) = Pr((A \cap B) \cup (A \cap C)) = Pr(A \cap B) + Pr(A \cap C) - Pr((A \cap B) \cap (A \cap C))$ . Since  $A, B, C$  are independent and  $(A \cap B) \cap (A \cap C) = (A \cap A) \cap (B \cap C) = A \cap B \cap C$ ,  $Pr(A \cap (B \cup C)) = Pr(A)Pr(B) + Pr(A)Pr(C) - Pr(A)Pr(B)Pr(C) = Pr(A)[Pr(B) + Pr(C) - Pr(B)Pr(C)] = Pr(A)[Pr(B) + Pr(C) - Pr(B \cap C)] = Pr(A)Pr(B \cup C)$ , so  $A$  and  $B \cup C$  are independent.

30. Suppose we toss a fair coin  $n$  times and we let the random variable  $X$  count the number of heads among the  $n$  tosses. Here we want  $Pr(X \geq 2) \geq 0.95$ , or  $\sum_{k=2}^n \binom{n}{k} (\frac{1}{2})^k (\frac{1}{2})^{n-k} = \sum_{k=2}^n \binom{n}{k} (\frac{1}{2})^n \geq 0.95$ .

Now  $\sum_{k=2}^n \binom{n}{k} (\frac{1}{2})^n \geq 0.95 \Rightarrow -\sum_{k=2}^n \binom{n}{k} (\frac{1}{2})^n \leq -0.95 \Rightarrow 1 - \sum_{k=2}^n \binom{n}{k} (\frac{1}{2})^n \leq 1 - 0.95 \Rightarrow \sum_{k=0}^1 \binom{n}{k} (\frac{1}{2})^n \leq 0.05 \Rightarrow (\frac{1}{2})^n + n(\frac{1}{2})^n = (n+1)(\frac{1}{2})^n \leq 0.05$

For  $n = 7$ ,  $(n+1)(\frac{1}{2})^n = 8(\frac{1}{2})^7 = \frac{8}{128} = 0.0625$ .

For  $n = 8$ ,  $(n+1)(\frac{1}{2})^n = 9(\frac{1}{2})^8 = \frac{9}{256} = 0.035156$

Consequently, the minimum number of tosses is 8.

31. (a) The probability that both tires in any single landing gear blow out is  $(0.1)(0.1) = 0.01$ . So the probability a landing gear will survive even a hard landing with at least one good tire is  $1 - 0.01 = 0.99$ .  
 (b) Assuming the landing gears operate independently of each other, the probability that the jet will be able to land safely even on a hard landing is  $(0.99)^3 = 0.970299$ .

32. For  $A, B \subseteq S$ ,  $1 = Pr(S) \geq Pr(A \cup B) = Pr(A) + Pr(B) - Pr(A \cap B)$ . Consequently,  $Pr(A \cap B) \geq Pr(A) + Pr(B) - 1$ .

33. Let  $A, B$  denote the events

$A$ : the exit door is open

$B$ : Marlo's selection of two keys includes the one key that opens the exit door

The answer then is given as  $Pr(A) + Pr(\bar{A} \cap B) = Pr(A) + Pr(\bar{A})Pr(B) = (\frac{1}{2}) + (\frac{1}{2})[(\frac{1}{1})(\frac{9}{1}) / \binom{10}{2}] = (\frac{1}{2}) + (\frac{1}{2})(\frac{1}{5}) = (\frac{1}{2}) + (\frac{1}{10}) = \frac{6}{10} = \frac{3}{5}$

34. Let  $A, B, C$  denote events

$A$ : the first and last outcomes are heads

$B$ : the first and last outcomes are tails

C: the eight tosses result in five heads and three tails.

The answer to the problem is  $Pr(C|A \cup B)$ . But  $Pr(C|A \cup B) = \frac{Pr(C \cap (A \cup B))}{Pr(A \cup B)} = \frac{Pr((C \cap A) \cup (C \cap B))}{Pr(A \cup B)}$ .

Since  $A, B$  are disjoint, it follows that  $C \cap A, C \cap B$  are disjoint. Further,

$$Pr(A \cup B) = Pr(A) + Pr(B) = \left(\frac{1}{2}\right)^2 + \left(\frac{1}{2}\right)^2 = \frac{1}{2}$$

$$Pr((C \cap A) \cup (C \cap B)) = Pr(C \cap A) + Pr(C \cap B) = \left(\frac{1}{2}\right) \left[ \binom{6}{3} \left(\frac{1}{2}\right)^3 \left(\frac{1}{2}\right)^3 \right] + \left(\frac{1}{2}\right) \left[ \binom{6}{5} \left(\frac{1}{2}\right)^5 \left(\frac{1}{2}\right) \right] = \left(\frac{1}{2}\right)^8 (20 + 6) = 13 \left(\frac{1}{2}\right)^7$$

$$\text{Consequently, } Pr(C|A \cup B) = [13 \left(\frac{1}{2}\right)^7] / \left(\frac{1}{2}\right) = (13) \left(\frac{1}{2}\right)^6 = \frac{13}{64}.$$

35.  $\binom{5}{3} (0.8)^3 (0.2)^2 + \binom{5}{4} (0.8)^4 (0.2) + \binom{5}{5} (0.8)^5 = 0.2048 + 0.4096 + 0.32768 = 0.94208$

36.  $Pr(19,000 \leq X \leq 21,000) = Pr(-1000 \leq X - 20,000 \leq 1000) = Pr(|X - E(X)| \leq 1000)$   
 Since  $\text{Var}(X) = 40,000 \text{ boxes}^2$ , we have  $\sigma_X = 200 \text{ boxes}$ . So  $Pr(|X - E(X)| \leq 1000) = Pr(|X - E(X)| \leq 5\sigma_X) \geq 1 - \frac{1}{5^2} = 1 - \frac{1}{25} = \frac{24}{25} = 0.96$ .

37. Success: one head and two tails - the probability for this is  $\binom{3}{1} \left(\frac{1}{2}\right)^1 \left(\frac{1}{2}\right)^2 = \frac{3}{8}$ .

$$n = 4, p = \frac{3}{8}$$

Among the four trials (of tossing three fair coins) we want two successes. The probability for this is  $\binom{4}{2} \left(\frac{3}{8}\right)^2 \left(\frac{5}{8}\right)^2 = (6)(9)(25)/2^{12} = 675/2^{11} = \frac{675}{2048}$ .

38. (a)  $\binom{16}{3} / \binom{22}{3} = \frac{16}{22} \cdot \frac{15}{21} \cdot \frac{14}{20} = \frac{4}{11} \doteq 0.363636$

(b)  $\binom{8}{1} \binom{8}{1} \binom{6}{1} / \binom{22}{3} = (3!) \left(\frac{8}{22}\right) \left(\frac{8}{21}\right) \left(\frac{6}{20}\right) = \frac{96}{385} \doteq 0.249351$

(c)  $[\binom{8}{2} \binom{14}{1} + \binom{8}{3}] / \binom{22}{3} = \frac{(3)(8)(7)(14) + (8)(7)(6)}{(22)(21)(20)} = \frac{16}{55} \doteq 0.290909$

39. (a)  $1 = \sum_{x=0}^4 Pr(X = x) = c(0 + 4) + c(1 + 4) + c(4 + 4) + c(9 + 4) + c(16 + 4) = c[4 + 5 + 8 + 13 + 20] = 50c$ , so  $c = \frac{1}{50} = 0.02$

(b)  $Pr(X > 1) = Pr(X \geq 2) = Pr(X = 2) + Pr(X = 3) + Pr(X = 4) = (0.02)(8) + (0.02)(13) + (0.02)(20) = 0.02(8 + 13 + 20) = (0.02)(41) = 0.82$

(c)  $Pr(X = 3|X \geq 2) = \frac{Pr(X = 3 \text{ and } X \geq 2)}{Pr(X \geq 2)} = \frac{Pr(X = 3)}{Pr(X \geq 2)} = (0.02)(13) / (0.02)(41) =$

$$\frac{13}{41} \doteq 0.317073$$

(d)  $E(X) = \sum_{x=0}^4 x \cdot Pr(X = x) = 0 \cdot (c)(4) + 1 \cdot (c)(5) + 2 \cdot (c)(8) + 3 \cdot (c)(13) + 4 \cdot (c)(20) = c[5 + 16 + 39 + 80] = 140c = 2.8$

(e)  $E(X^2) = \sum_{x=0}^4 x^2 \cdot Pr(X = x) = 0^2 \cdot (4c) + 1^2 \cdot (5c) + 2^2 \cdot (8c) + 3^2 \cdot (13c) + 4^2 \cdot (20c) = 474c = 9.48$

$$\text{Var}(X) = E(X^2) - E(X)^2 = 9.48 - (2.8)^2 = 1.64$$

40. For each student the probability that all five marbles are green is  $(7/11)^5$ . Therefore, the probability all 12 students draw only green marbles is  $[(7/11)^5]^{12} = (7/11)^{60}$ . Consequently, the probability that at least one student draws at least one red marble is  $1 - (7/11)^{60}$ .

41. (a) To finish with a straight flush, Maureen must draw (i) the 4 and 5 of diamonds; (ii) the 5 and 9 of diamonds; or (iii) the 9 and 10 of diamonds. The probability for each of these three situations is  $\binom{2}{2}/\binom{47}{2}$ , so the answer is  $3/\binom{47}{2}$ .
- (b) Maureen will finish with a flush if she draws any two of the remaining ten diamonds, which she can do in  $\binom{10}{2}$  ways. However, for three choices [as described in part (a)], she actually finishes with a straight flush. Consequently, the answer here is  $[\binom{10}{2} - 3]/\binom{47}{2}$ .
- (c) To finish with a straight from 4 to 8, Maureen must select one of the four 4s and one of the four 5s. This she can do in  $\binom{4}{1}\binom{4}{1}$  ways. For the straights from 5 to 9 and 6 to 10 there are likewise  $\binom{4}{1}\binom{4}{1}$  possibilities. However, these  $3\binom{4}{1}\binom{4}{1}$  straights include three straight flushes, so the answer is  $[3\binom{4}{1}\binom{4}{1} - 3]/\binom{47}{2}$ .

42.  $\binom{2}{1}\binom{2}{1}\binom{2}{1}\binom{2}{1}\binom{2}{1}\binom{2}{1}\binom{2}{1}\binom{2}{1}\binom{32}{4}/\binom{48}{12}$

43. The total number of chips in the grab bag is  $1 + 2 + 3 + \cdots + n = n(n+1)/2$ , and the probability a chip with  $i$  on it is selected is  $2i/[n(n+1)]$ . Let  $A, B$  be the events.

$A$ : the chip with 1 on it is selected

$B$ : a red chip is selected.

$$Pr(A|B) = Pr(A \cap B)/Pr(B) = Pr(A)/Pr(B).$$

$$Pr(A) = 1/[n(n+1)/2] = 2/[n(n+1)].$$

$$Pr(B) = [1+2+3+\cdots+m]/[n(n+1)/2] = [m(m+1)/2]/[n(n+1)/2] = [m(m+1)]/[n(n+1)].$$

$$\text{Consequently, } Pr(A|B) = \frac{2/[n(n+1)]}{[m(m+1)]/[n(n+1)]} = 2/[m(m+1)].$$

(a)  $x$              $Pr(X = x)$

1             $\binom{6}{1}(1/6)^3 = 1/36$

2             $\binom{6}{2}(1/6)^3 = 15/36 = 5/12$

3             $\binom{6}{3}(1/6)^3 = 20/36 = 5/9$

44. (b)  $E(X) = \sum_{x=1}^3 x \cdot Pr(X = x) = (1)(1/36) + (2)(15/36) + (3)(20/36)$   
 $= (1/36)[1 + 30 + 60] = 91/36$

(c)  $E(X^2) = \sum_{x=1}^3 x^2 \cdot Pr(X = x) = (1)(1/36) + (4)(15/36) + (9)(20/36)$   
 $= (1/36)[1 + 60 + 180] = 241/36$

$$\text{Var}(X) = E(X^2) - E(X)^2 = (241/36) - (91/36)^2$$

$$= [8676 - 8281]/1296 = 395/1296$$

(a)	Outcome	Probability of Outcome	$x$ , the number of runs
	$HHH$	$(3/4)^3 = 27/64$	1
	$HHT$	$(3/4)^2(1/4) = 9/64$	2
45.	$HTH$	$(3/4)(1/4)(3/4) = 9/64$	3
	$THH$	$(1/4)(3/4)^2 = 9/64$	2
	$HTT$	$(3/4)(1/4)^2 = 3/64$	2
	$THT$	$(1/4)(3/4)(1/4) = 3/64$	3
	$TTH$	$(1/4)^2(3/4) = 3/64$	2
	$TTT$	$(1/4)^3 = 1/64$	1

The probability distribution for  $X$ :

$x$	$Pr(X = x)$
1	$(27/64) + (1/64) = 28/64 = 7/16$
2	$(9/64) + (9/64) + (3/64) + (3/64) = 24/64 = 3/8$
3	$(9/64) + (3/64) = 12/64 = 3/16$
(b) $E(X)$	$= \sum_{x=1}^3 x \cdot Pr(X = x) = (1)(7/16) + (2)(3/8) + (3)(3/16)$ $= (1/16)[7 + 12 + 9] = 28/16 = 7/4$
(c) $E(X^2)$	$= \sum_{x=1}^3 x^2 \cdot Pr(X = x) = (1)(7/16) + (4)(3/8) + (9)(3/16)$ $= (1/16)[7 + 24 + 27] = 58/16 = 29/8$
$Var(X)$	$= E(X^2) - E(X)^2 = (29/8) - (7/4)^2 = (29/8) - (49/16)$ $= (58 - 49)/16 = 9/16$
So $\sigma_X$	$= \sqrt{9/16} = 3/4.$

CHAPTER 4  
PROPERTIES OF THE INTEGERS: MATHEMATICAL INDUCTION

**Section 4.1**

1. (a)  $S(n) : 1^2 + 3^2 + 5^2 + \dots + (2n - 1)^2 = (n)(2n - 1)(2n + 1)/3$ .

$S(1) : 1^2 = (1)(1)(3)/3$ . This is true.

Assume  $S(k) : 1^2 + 3^2 + \dots + (2k - 1)^2 = (k)(2k - 1)(2k + 1)/3$ , for some  $k \geq 1$ .

Consider  $S(k+1)$ .  $[1^2 + 3^2 + \dots + (2k - 1)^2] + (2k + 1)^2 = [(k)(2k - 1)(2k + 1)/3] + (2k + 1)^2 = [(2k + 1)/3][k(2k - 1) + 3(2k + 1)] = [(2k + 1)/3][2k^2 + 5k + 3] = (k + 1)(2k + 1)(2k + 3)/3$ , so  $S(k) \implies S(k + 1)$  and the result follows for all  $n \in \mathbf{Z}^+$  by the Principle of Mathematical Induction.

(c)  $S(n) : \sum_{i=1}^n \frac{1}{i(i+1)} = \frac{n}{n+1}$

$S(1) : \sum_{i=1}^1 \frac{1}{i(i+1)} = \frac{1}{1(2)} = \frac{1}{1+1}$ , so  $S(1)$  is true.

Assume  $S(k) : \sum_{i=1}^k \frac{1}{i(i+1)} = \frac{k}{k+1}$ . Consider  $S(k + 1)$ .

$\sum_{i=1}^{k+1} \frac{1}{i(i+1)} = \sum_{i=1}^k \frac{1}{i(i+1)} + \frac{1}{(k+1)(k+2)} = \frac{k}{k+1} + \frac{1}{(k+1)(k+2)} = [k(k+2) + 1]/[(k+1)(k+2)] = (k+1)/(k+2)$ , so  $S(k) \implies S(k + 1)$  and the result follows for all  $n \in \mathbf{Z}^+$  by the Principle of Mathematical Induction.

The proofs of the remaining parts are similar.

2. (a)  $S(n) : \sum_{i=1}^n 2^{i-1} = 2^n - 1$

$S(1) : \sum_{i=1}^1 2^{i-1} = 2^{1-1} = 2^1 - 1$ , so  $S(1)$  is true.

Assume  $S(k) : \sum_{i=1}^k 2^{i-1} = 2^k - 1$ . Consider  $S(k + 1)$ .

$\sum_{i=1}^{k+1} 2^{i-1} = \sum_{i=1}^k 2^{i-1} + 2^k = 2^k - 1 + 2^k = 2^{k+1} - 1$ , so  $S(k) \implies S(k + 1)$  and the result is true for all  $n \in \mathbf{Z}^+$  by the Principle of Mathematical Induction.

(b) For  $n = 1$ ,  $\sum_{i=1}^1 i(2^i) = 2 = 2 + (1 - 1)2^{1+1}$ , so the statement  $S(1)$  is true. Assume  $S(k)$  true - that is,  $\sum_{i=1}^k i(2^i) = 2 + (k - 1)2^{k+1}$ . For  $n = k + 1$ ,  $\sum_{i=1}^{k+1} i(2^i) = \sum_{i=1}^k i(2^i) + (k + 1)2^{k+1} = 2 + (k - 1)2^{k+1} + (k + 1)2^{k+1} = 2 + (2k)2^{k+1} = 2 + k \cdot 2^{k+2}$ , so  $S(n)$  is true for all  $n \in \mathbf{Z}^+$  by the Principle of Mathematical Induction.

(c) For  $n = 1$ , we find that  $\sum_{i=1}^1 (i)(i!) = 1 = (1 + 1)! - 1$ , so  $S(1)$  is true. We assume the truth of  $S(k)$  - that is,  $\sum_{i=1}^k i(i!) = (k + 1)! - 1$ . Now for the case where  $n = k + 1$  we have  $\sum_{i=1}^{k+1} i(i!) = \sum_{i=1}^k i(i!) + (k + 1)(k + 1)! = (k + 1)! - 1 + (k + 1)(k + 1)! = [1 + (k + 1)](k + 1)! - 1 = (k + 2)(k + 1)! - 1 = (k + 2)! - 1$ . Hence  $S(k) \implies S(k + 1)$ , and since  $S(1)$  is true it follows that the statement is true for all  $n \geq 1$ , by the Principle of Mathematical Induction.

3. (a) From  $\sum_{i=1}^n i^3 + (n + 1)^3 = \sum_{i=0}^n (i^3 + 3i^2 + 3i + 1) = \sum_{i=1}^n i^3 + 3 \sum_{i=1}^n i^2 + 3 \sum_{i=1}^n i + \sum_{i=0}^n 1$ , we have  $(n + 1)^3 = 3 \sum_{i=1}^n i^2 + 3 \sum_{i=1}^n i + (n + 1)$ . Consequently,

$$\begin{aligned}
3 \sum_{i=1}^n i^2 &= (n^3 + 3n^2 + 3n + 1) - 3[(n)(n+1)/2] - n - 1 \\
&= n^3 + (3/2)n^2 + (1/2)n \\
&= (1/2)[2n^3 + 3n^2 + n] = (1/2)n(2n^2 + 3n + 1) \\
&= (1/2)n(n+1)(2n+1), \text{ so}
\end{aligned}$$

$\sum_{i=1}^n i^2 = (1/6)n(n+1)(2n+1)$  (as shown in Example 4.4).

(b) From  $\sum_{i=1}^n i^4 + (n+1)^4 = \sum_{i=0}^n (i+1)^4 = \sum_{i=0}^n (i^4 + 4i^3 + 6i^2 + 4i + 1) = \sum_{i=1}^n i^4 + 4 \sum_{i=1}^n i^3 + 6 \sum_{i=1}^n i^2 + 4 \sum_{i=1}^n i + \sum_{i=0}^n 1$ , it follows that  $(n+1)^4 = 4 \sum_{i=1}^n i^3 + 6 \sum_{i=1}^n i^2 + 4 \sum_{i=1}^n i + \sum_{i=0}^n 1$ .

Consequently,

$$4 \sum_{i=1}^n i^3 = (n+1)^4 - 6[n(n+1)(2n+1)/6] - 4[n(n+1)/2] - (n+1) = n^4 + 4n^3 + 6n^2 + 4n + 1 - (2n^3 + 3n^2 + n) - (2n^2 + 2n) - (n+1) = n^4 + 2n^3 + n^2 = n^2(n^2 + 2n + 1) = n^2(n+1)^2.$$

So  $\sum_{i=1}^n i^3 = (1/4)n^2(n+1)^2$  [as shown in part (d) of Exercise 1 for this section].

From  $\sum_{i=1}^n i^5 + (n+1)^5 = \sum_{i=0}^n (i+1)^5 = \sum_{i=0}^n (i^5 + 5i^4 + 10i^3 + 10i^2 + 5i + 1) = \sum_{i=1}^n i^5 + 5 \sum_{i=1}^n i^4 + 10 \sum_{i=1}^n i^3 + 10 \sum_{i=1}^n i^2 + 5 \sum_{i=1}^n i + \sum_{i=0}^n 1$ , we have  $5 \sum_{i=1}^n i^4 = (n+1)^5 - (10/4)n^2(n+1)^2 - (10/6)n(n+1)(2n+1) - (5/2)n(n+1) - (n+1)$ . So

$$\begin{aligned}
5 \sum_{i=1}^n i^4 &= n^5 + 5n^4 + 10n^3 + 10n^2 + 5n + 1 - (5/2)n^4 \\
&\quad - 5n^3 - (5/2)n^2 - (10/3)n^3 - 5n^2 - (5/3)n - (5/2)n^2 - (5/2)n - n - 1 \\
&= n^5 + (5/2)n^4 + (5/3)n^3 - (1/6)n.
\end{aligned}$$

Consequently,  $\sum_{i=1}^n i^4 = (1/30)n(n+1)(6n^3 + 9n^2 + n - 1)$ .

4. Let  $x_1, x_2, \dots, x_{25}$  denote the numbers (in their order on the wheel), and assume that  $x_1 + x_2 + x_3 < 39, x_2 + x_3 + x_4 < 39, \dots, x_{24} + x_{25} + x_1 < 39$ , and  $x_{25} + x_1 + x_2 < 39$ . Then  $\sum_{i=1}^{25} 3x_i < 25(39)$ . But  $\sum_{i=1}^{25} 3x_i = 3 \sum_{i=1}^{25} x_i = (3)(25)(26)/2 = (39)(25)$ .

5. (a) 7626 (b) 627,874

6. a) The typical palindrome under study here has the form  $abba$  where  $1 \leq a \leq 9$  and  $0 \leq b \leq 9$ . Consequently there are  $9 \cdot 10 = 90$  such palindromes, by the rule of product. Their sum is  $\sum_{a=1}^9 (\sum_{b=0}^9 abba) = \sum_{a=1}^9 \sum_{b=0}^9 (1001a + 110b) = \sum_{a=1}^9 [10(1001a) + 110 \sum_{b=0}^9 b] = \sum_{a=1}^9 (10010a + 110(9 \cdot 10/2)) = 10010 \sum_{a=1}^9 a + \sum_{a=1}^9 4950 = 10010(9 \cdot 10/2) + 9(4950) = 450450 + 44550 = 495000$ .

b) begin

sum := 0

for a := 1 to 9 do

for b := 0 to 9 do

sum := sum + 1001 \* a + 110 \* b

print sum

end

7.

$$\begin{aligned}
 4n + 110 &= 6 + 8 + 10 + \cdots + [6 + (n - 1)2] \\
 &= 6n + [0 + 2 + 4 + \cdots + (n - 1)2] \\
 &= 6n + 2[1 + 2 + \cdots + (n - 1)] \\
 &= 6n + 2[(n - 1)(n)/2] \\
 &= 6n + (n - 1)(n) = n^2 + 5n \\
 n^2 + n - 110 &= (n + 11)(n - 10) = 0,
 \end{aligned}$$

so  $n = 10$  – the number of layers.

8. Here we have  $\sum_{i=1}^n i^2 = (n)(n + 1)(2n + 1)/6 = (2n)(2n + 1)/2 = \sum_{i=1}^{2n} i,$

and  $(n)(n + 1)(2n + 1)/6 = (2n)(2n + 1)/2 \Rightarrow (n)(n + 1)/6 = (2n)/2 \Rightarrow$

$(n + 1)/6 = 1 \Rightarrow n + 1 = 6 \Rightarrow n = 5.$

9. (a)  $\sum_{i=11}^{33} i = \sum_{i=1}^{33} i - \sum_{i=1}^{10} i = [(33)(34)/2] - [(10)(11)/2] = 561 - 55 = 506$

(b)  $\sum_{i=11}^{33} i^2 = \sum_{i=1}^{33} i^2 - \sum_{i=1}^{10} i^2 = [(33)(34)(67)/6] - [(10)(11)(21)/6] = 12144$

10.  $\sum_{i=51}^{100} t_i = \sum_{i=1}^{100} t_i - \sum_{i=1}^{50} t_i = (100)(101)(102)/6 - (50)(51)(52)/6 = 171,700 - 22,100 = 149,600.$

11. a)  $\sum_{i=1}^n t_{2i} = \sum_{i=1}^n \frac{(2i)(2i+1)}{2} = \sum_{i=1}^n (2i^2 + i) = 2 \sum_{i=1}^n i^2 + \sum_{i=1}^n i = 2[(n)(n + 1)(2n + 1)/6] + [n(n + 1)/2] = [n(n + 1)(2n + 1)/3] + [n(n + 1)/2] = n(n + 1)[\frac{2n+1}{3} + \frac{1}{2}] = n(n + 1)[\frac{4n+5}{6}] = n(n + 1)(4n + 5)/6.$

b)  $\sum_{i=1}^{100} t_{2i} = 100(101)(405)/6 = 681,750.$

c) **begin**

    sum := 0

**for** i := 1 **to** 100 **do**

        sum := sum + (2 \* i) \* (2 \* i + 1)/2

**print** sum

**end**

12. (a)  $(\cos \theta + i \sin \theta)^2 = \cos^2 \theta + 2i \sin \theta \cos \theta - \sin^2 \theta = (\cos^2 \theta - \sin^2 \theta) + i(2 \sin \theta \cos \theta) = \cos 2\theta + i \sin 2\theta.$

(b)  $S(n) : (\cos \theta + i \sin \theta)^n = \cos n\theta + i \sin n\theta.$   $S(1)$  is true, so assume  $S(k) : (\cos \theta + i \sin \theta)^k = (\cos k\theta + i \sin k\theta).$  Consider  $S(k+1) : (\cos \theta + i \sin \theta)^{k+1} = (\cos \theta + i \sin \theta)^k (\cos \theta + i \sin \theta) = (\cos k\theta + i \sin k\theta) \cdot (\cos \theta + i \sin \theta) = (\cos k\theta \cos \theta - \sin k\theta \sin \theta) + i(\sin \theta \cos k\theta + \sin k\theta \cos \theta) = \cos(k + 1)\theta + i \sin(k + 1)\theta.$  So  $S(k) \implies S(k + 1)$  and the result is true for all  $n \in \mathbb{Z}^+$  by the Principle of Mathematical Induction.

(c)  $(1 + i)^{100} = 2^{50}(\cos 4500^\circ + i \sin 4500^\circ) = 2^{50}(\cos 180^\circ + i \sin 180^\circ) = -(2^{50}).$

13. (a) There are  $49(= 7^2)$   $2 \times 2$  squares and  $36(= 6^2)$   $3 \times 3$  squares. In total there are  $1^2 + 2^2 + 3^2 + \cdots + 8^2 = (8)(8+1)(2 \cdot 8+1)/6 = (8)(9)(17)/6 = 204$  squares.
- (b) For each  $1 \leq k \leq n$  the  $n \times n$  chessboard contains  $(n-k+1)^2$   $k \times k$  squares. In total there are  $1^2 + 2^2 + 3^2 + \cdots + n^2 = n(n+1)(2n+1)/6$  squares.
14. For  $n = 4$  we have  $2^4 = 16 < 24 = 4!$ , so the statement  $S(4)$  is true. Assume the truth of  $S(k)$  – that is,  $2^k < k!$ . For  $k \geq 4$ ,  $2 < k+1$ , and  $[(2^k < k!) \wedge (2 < k+1)] \implies (2^k)(2) < (k!)(k+1)$ , or  $2^{k+1} < (k+1)!$ . Hence  $S(n)$  is true for all  $n \geq 4$  by the Principle of Mathematical Induction.
15. For  $n = 5$ ,  $2^5 = 32 > 25 = 5^2$ . Assume the result for  $n = k(\geq 5)$ :  $2^k > k^2$ . For  $k > 2$ ,  $k(k-2) > 1$ , or  $k^2 > 2k+1$ . But  $2^k > k^2 \implies 2^k + 2^k > k^2 + k^2 \implies 2^{k+1} > k^2 + k^2 > k^2 + (2k+1) = (k+1)^2$ . Hence the result is true for  $n \geq 5$  by the Principle of Mathematical Induction.
16. (a) 3 (b)  $s_2 = 2$ ;  $s_4 = 4$

(c) For  $n \geq 1$ ,  $s_n = \sum_{\emptyset \neq A \subseteq X_n} \frac{1}{p_A} = n$ .

Proof: For  $n = 1$ ,  $s_1 = \frac{1}{1} = 1$ , so this first case is true and establishes the basis step. Now, for the inductive step, assume the result true for  $n = k(\geq 1)$ . That is,  $s_k = \sum_{\emptyset \neq A \subseteq X_k} \frac{1}{p_A} = k$ .

For  $n = k+1$  we find that  $s_{k+1} = \sum_{\emptyset \neq A \subseteq X_{k+1}} \frac{1}{p_A} = \sum_{\emptyset \neq B \subseteq X_k} \frac{1}{p_B} + \sum_{\{k+1\} \subseteq C \subseteq X_{k+1}} \frac{1}{p_C}$ , where the first sum is taken over all nonempty subsets  $B$  of  $X_k$  and the second sum over all subsets  $C$  of  $X_{k+1}$  that contain  $k+1$ . Then  $s_{k+1} = s_k + [(\frac{1}{k+1}) + (\frac{1}{k+1})s_k] = k + (\frac{1}{k+1}) + (\frac{1}{k+1})k = k + (\frac{1}{k+1})(1+k) = k+1$ . Consequently, we have deduced the truth for  $n = k+1$  from that of  $n = k$ . The result now follows for all  $n \geq 1$  by the Principle of Mathematical Induction.

17. (a) Once again we start at  $n = 0$ . Here we find that  $1 = 1 + (0/2) \leq H_1 = H_{2^0}$ , so this first case is true. Assuming the truth for  $n = k(\in \mathbb{N})$  we obtain the induction hypothesis

$$1 + (k/2) \leq H_{2^k}.$$

Turning now to the case where  $n = k+1$  we find  $H_{2^{k+1}} = H_{2^k} + [1/(2^k+1)] + [1/(2^k+2)] + \cdots + [1/(2^k+2^k)] \geq H_{2^k} + [1/(2^k+2^k)] + [1/(2^k+2^k)] + \cdots + [1/(2^k+2^k)] = H_{2^k} + 2^k[1/2^{k+1}] = H_{2^k} + (1/2) \geq 1 + (k/2) + (1/2) = 1 + (k+1)/2$ .

The result now follows for all  $n \geq 0$  by the Principle of Mathematical Induction.

- (b) Starting with  $n = 1$  we find that

$$\sum_{j=1}^1 jH_j = H_1 = 1 = [(2)(1)/2](3/2) - [(2)(1)/4] = [(2)(1)/2]H_2 - [(2)(1)/4].$$

Assuming the truth of the given statement for  $n = k$ , we have

$$\sum_{j=1}^k jH_j = [(k+1)(k)/2]H_{k+1} - [(k+1)(k)/4].$$

For  $n = k + 1$  we now find that

$$\begin{aligned} \sum_{j=1}^{k+1} jH_j &= \sum_{j=1}^k jH_j + (k+1)H_{k+1} \\ &= [(k+1)(k)/2]H_{k+1} - [(k+1)(k)/4] + (k+1)H_{k+1} \\ &= (k+1)[1 + (k/2)]H_{k+1} - [(k+1)(k)/4] \\ &= (k+1)[1 + (k/2)][H_{k+2} - (1/(k+2))] - [(k+1)(k)/4] \\ &= [(k+2)(k+1)/2]H_{k+2} - [(k+1)(k+2)]/[2(k+2)] - [(k+1)(k)/4] \\ &= [(k+2)(k+1)/2]H_{k+2} - [(1/4)[2(k+1) + k(k+1)]] \\ &= [(k+2)(k+1)/2]H_{k+2} - [(k+2)(k+1)/4]. \end{aligned}$$

Consequently, by the Principle of Mathematical Induction, it follows that the given statement is true for all  $n \in \mathbf{Z}^+$ .

18. Conjecture: For all  $n \in \mathbf{N}$ ,  $(n^2 + 1) + (n^2 + 2) + (n^2 + 3) + \dots + (n + 1)^2 = \sum_{i=1}^{2n+1} (n^2 + i) = n^3 + (n + 1)^3$ .

Proof: 
$$\sum_{i=1}^{2n+1} (n^2 + i) = n^2 \sum_{i=1}^{2n+1} 1 + \sum_{i=1}^{2n+1} i = n^2(2n+1) + (2n+1)(2n+2)/2 = 2n^3 + n^2 + (2n+1)(n+1) = 2n^3 + n^2 + 2n^2 + 3n + 1 = n^3 + [n^3 + 3n^2 + 3n + 1] = n^3 + (n+1)^3.$$

19. Assume  $S(k)$  true for some  $k \geq 1$ . For  $S(k+1)$ ,  $\sum_{i=1}^{k+1} i = [k + (1/2)]^2/2 + (k+1) = ((k^2 + k) + (1/4) + 2k + 2)/2 = [(k+1)^2 + (k+1) + (1/4)]/2 = [(k+1) + (1/2)]^2/2$ .  
 $S(k) \implies S(k+1)$ . However, we have no first value of  $k$  where  $S(k)$  is true:  
 For each  $k \geq 1$ ,  $\sum_{i=1}^k i = (k)(k+1)/2$  and  $(k)(k+1)/2 = [k + (1/2)]^2/2 \implies 0 = 1/4$ .

20. For  $n = 0$ ,  $S = \{a_1\}$  and 0 comparisons are required. Since  $0 = 0 \cdot 2^0$ , the result is true when  $n = 0$ . Assume the result for  $n = k (\geq 0)$  and consider the case  $n = k + 1$ . If  $|S| = 2^{k+1}$  then  $S = S_1 \cup S_2$  where  $|S_1| = |S_2| = 2^k$ . By the induction hypothesis the number of comparisons needed to place the elements in each of  $S_1, S_2$  in ascending order is bounded by  $k \cdot 2^k$ . Therefore, by the given information, the elements in  $S$  can be placed in ascending order by making at most a total of  $(k \cdot 2^k) + (k \cdot 2^k) + (2^k + 2^k - 1) = (k+1)2^{k+1} - 1 \leq (k+1)2^{k+1}$  comparisons.

21. For  $x, n \in \mathbf{Z}^+$ , let  $S(n)$  denote the statement: If the program reaches the top of the **while** loop, after the two loop instructions are executed  $n(> 0)$  times, then the value of the integer variable *answer* is  $x(n!)$ .

First consider  $S(1)$ , the statement for the case where  $n = 1$ . Here the program (if it reaches the top of the **while** loop) will result in one execution of the **while** loop:  $x$  will be assigned the value  $x \cdot 1 = x(1!)$ , and the value of  $n$  will be decreased to 0. With the value of  $n$  equal to 0 the loop is not processed again and the value of the variable *answer* is  $x(1!)$ . Hence  $S(1)$  is true.

Now assume the truth for  $n = k$ : For  $x, k \in \mathbf{Z}^+$ , if the program reaches the top of the **while** loop, then upon exiting the loop, the value of the variable *answer* is  $x(k!)$ . To establish  $S(k + 1)$ , if the program reaches the top of the **while** loop, then the following occur during the first execution:

The value assigned to the variable  $x$  is  $x(k + 1)$ .

The value of  $n$  is decreased to  $(k + 1) - 1 = k$ .

But then we can apply the induction hypothesis to the integers  $x(k + 1)$  and  $k$ , and after we exit the **while** loop for these values, the value of the variable *answer* is  $(x(k + 1))(k!) = x(k + 1)!$

Consequently,  $S(n)$  is true for all  $n \geq 1$ , and we have verified the correctness of this program segment by using the Principle of Mathematical Induction.

22. If  $n = 0$ , then the statement ' $n \neq 0$ ' is false so the **while** loop is bypassed and the value assigned to *answer* is  $x = x + 0 \cdot y$ . So the result is true in the first case.

Now assume the result true for  $n = k$  - that is, for  $x, y \in \mathbf{R}$ , if the program reaches the top of the **while** loop with  $k \in \mathbf{Z}$ ,  $k \geq 0$ , then upon bypassing the loop when  $k = 0$ , or executing the two loop instructions  $k(> 0)$  times, then the value assigned to *answer* is  $x + ny$ . To establish the result for  $n = k + 1$ , suppose the program reaches the top of the **while** loop. Since  $k \geq 0$ ,  $n = k + 1 > 0$ , so the loop is not bypassed. During the first pass through the **while** loop we find that

The value assigned to  $x$  is  $x + y$ ; and

The value of  $n$  is decreased to  $(k + 1) - 1 = k$ .

Now we apply the induction hypothesis to the real numbers  $x + y$  and  $y$  and the nonnegative integer  $n - 1 = k$ , and upon bypassing the loop when  $k = 0$ , or executing the two loop instructions  $k(> 0)$  times, then the value assigned to *answer* is

$$(x + y) + ky = x + (k + 1)y.$$

The result now follows for all  $n \in \mathbf{N}$  by the Principle of Mathematical Induction.

23. (a) The result is true for  $n = 2, 4, 5, 6$ . Assume the result is true for all  $n = 2, 4, 5, \dots, k - 1, k$ , where  $k \geq 6$ . If  $n = k + 1$ , then  $n = 2 + (k - 1)$ , and since the result is true for  $k - 1$ , it follows by induction that it is true for  $k + 1$ . Consequently, by the Alternative Form of the Principle of Mathematical Induction, every  $n \in \mathbf{Z}^+$ ,  $n \neq 1, 3$ , can be written as a sum of 2's and 5's.

(b)  $24 = 5 + 5 + 7 + 7$

$25 = 5 + 5 + 5 + 5 + 5$

$26 = 5 + 7 + 7 + 7$

$$27 = 5 + 5 + 5 + 5 + 7$$

$$28 = 7 + 7 + 7 + 7$$

Hence the result is true for all  $24 \leq n \leq 28$ . Assume the result true for  $24 \leq n \leq 28 \leq k$ , and consider  $n = k + 1$ . Since  $k + 1 \geq 29$ , we may write  $k + 1 = [(k + 1) - 5] + 5 = (k - 4) + 5$ , where  $k - 4$  can be expressed as a sum of 5's and 7's. Hence  $k + 1$  can be expressed as such a sum and the result follows for all  $n \geq 24$  by the Alternative Form of the Principle of Mathematical Induction.

24. (a)  $a_3 = 3 \quad a_4 = 5 \quad a_5 = 8 \quad a_6 = 13 \quad a_7 = 21$

(b)  $a_1 = 1 < (7/4)^1$ , so the result is true for  $n = 1$ . Likewise,  $a_2 = 2 < \frac{49}{16} = (7/4)^2$  and the result holds for  $n = 2$ .

Assume the result true for all  $1 \leq n \leq k$ , where  $k \geq 2$ . Now for  $n = k + 1$  we have  $a_{k+1} = a_k + a_{k-1} < (7/4)^k + (7/4)^{k-1} = (7/4)^{k-1}[(7/4) + 1] = (7/4)^{k-1}(11/4) = (7/4)^{k-1}(44/16) < (7/4)^{k-1}(49/16) = (7/4)^{k-1}(7/4)^2 = (7/4)^{k+1}$ . So by the Alternative Form of the Principle of Mathematical Induction it follows that  $a_n < (7/4)^n$  for all  $n \geq 1$ .

25.

$$\begin{aligned} E(X) &= \sum_x x Pr(X = x) = \sum_{x=1}^n x \left(\frac{1}{n}\right) = \left(\frac{1}{n}\right) \sum_{x=1}^n x = \left(\frac{1}{n}\right) \left[\frac{n(n+1)}{2}\right] = \frac{n+1}{2} \\ E(X^2) &= \sum_x x^2 Pr(X = x) = \sum_{x=1}^n x^2 \left(\frac{1}{n}\right) = \left(\frac{1}{n}\right) \sum_{x=1}^n x^2 = \left(\frac{1}{n}\right) \left[\frac{n(n+1)(2n+1)}{6}\right] = \frac{(n+1)(2n+1)}{6} \\ \text{Var}(X) &= E(X^2) - E(X)^2 = \frac{(n+1)(2n+1)}{6} - \frac{(n+1)^2}{4} = (n+1) \left[\frac{2n+1}{6} - \frac{n+1}{4}\right] \\ &= (n+1) \left[\frac{4n+2-(3n+3)}{12}\right] = \frac{(n+1)(n-1)}{12} = \frac{n^2-1}{12}. \end{aligned}$$

26.

a)  $a_1 = \sum_{i=0}^{1-1} \binom{0}{i} a_i a_{(1-1)-i} = \binom{0}{0} a_0 a_0 = a_0^2$   
 $a_2 = \sum_{i=0}^{2-1} \binom{1}{i} a_i a_{(2-1)-i} = \binom{1}{0} a_0 a_1 + \binom{1}{1} a_1 a_0 = 2a_0^3$

b)  $a_3 = \sum_{i=0}^{3-1} \binom{2}{i} a_i a_{(3-1)-i} = \sum_{i=0}^2 \binom{2}{i} a_i a_{2-i}$   
 $= \binom{2}{0} a_0 a_2 + \binom{2}{1} a_1 a_1 + \binom{2}{2} a_2 a_0$   
 $= a_0(2a_0^3) + 2(a_0^2)(a_0^2) + (2a_0^3)a_0 = 6a_0^4$

c)  $a_4 = \sum_{i=0}^{4-1} \binom{3}{i} a_i a_{(4-1)-i} = \sum_{i=0}^3 \binom{3}{i} a_i a_{3-i}$   
 $= \binom{3}{0} a_0 a_3 + \binom{3}{1} a_1 a_2 + \binom{3}{2} a_2 a_1 + \binom{3}{3} a_3 a_0$   
 $= a_0(6a_0^4) + 3(a_0^2)(2a_0^3) + 3(2a_0^3)(a_0^2) + (6a_0^4)(a_0)$   
 $= 24a_0^5$

c) For  $n \geq 0$ ,  $a_n = (n!)a_0^{n+1}$ .

Proof: (By the Alternative Form of the Principle of Mathematical Induction)

The result is true for  $n = 0$  and this establishes the basis step. [In fact, the calculations in parts (a) and (b) show the result is also true for  $n = 1, 2, 3$ , and 4.] Assuming the result true for  $n = 0, 1, 2, 3, \dots, k (\geq 0)$  - that is, that  $a_n = (n!)a_0^{n+1}$  for  $n = 0, 1, 2, 3, \dots, k (\geq 0)$  - we find that

$$\begin{aligned} a_{k+1} &= \sum_{i=0}^k \binom{k}{i} a_i a_{k-i} \\ &= \sum_{i=0}^k \binom{k}{i} (i!)(a_0^{i+1})(k-i)!(a_0^{k-i+1}) \\ &= \sum_{i=0}^k \binom{k}{i} (i!)(k-i)! a_0^{k+2} \\ &= \sum_{i=0}^k k! a_0^{k+2} \\ &= (k+1)[k! a_0^{k+2}] = (k+1)! a_0^{k+2}. \end{aligned}$$

So the truth of the result for  $n = 0, 1, 2, \dots, k (\geq 0)$  implies the truth of the result for  $n = k + 1$ . Consequently, for all  $n \geq 0$ ,  $a_n = (n!)a_0^{n+1}$  by the Alternative Form of the Principle of Mathematical Induction.

27. Let  $T = \{n \in \mathbb{Z}^+ | n \geq n_0 \text{ and } S(n) \text{ is false}\}$ . Since  $S(n_0), S(n_0 + 1), S(n_0 + 2), \dots, S(n_1)$  are true, we know that  $n_0, n_0 + 1, n_0 + 2, \dots, n_1 \notin T$ . If  $T \neq \emptyset$ , then by the Well-Ordering Principle  $T$  has a least element  $r$ , because  $T \subseteq \mathbb{Z}^+$ . However, since  $S(n_0), S(n_0 + 1), \dots, S(r - 1)$  are true, it follows that  $S(r)$  is true. Hence  $T = \emptyset$  and the result follows.

28. (a) (i) The number of compositions of 5 that start with 1 is the number of compositions of 4, which is  $2^{4-1} = 2^3 = 8$ .

(ii)  $2^{3-1} = 2^2 = 4$

(iii)  $2^{2-1} = 2^1 = 2$

(iv)  $2^{1-1} = 2^0 = 1$

(v) 1

(b) In total, there are  $2^{(n+1)-1} = 2^n$  compositions for the fixed positive integer  $n + 1$ . For  $1 \leq i \leq n$ , there are  $2^{(n+1-i)-1} = 2^{n-i}$  compositions of  $n + 1$  that start with  $i$ . In addition, there is the composition consisting of only one summand - namely,  $(n + 1)$ . So we have counted the same collection of objects - that is, the compositions of  $n + 1$  - in two ways. This gives us  $2^n = \sum_{i=1}^n 2^{n-i} + 1 = (2^{n-1} + 2^{n-2} + 2^{n-3} + \dots + 2^2 + 2^1 + 2^0) + 1 = (2^0 + 2^1 + 2^2 + \dots + 2^{n-3} + 2^{n-2} + 2^{n-1}) + 1 = \sum_{i=0}^{n-1} 2^i + 1$ . Consequently,  $\sum_{i=0}^{n-1} 2^i = 2^n - 1$ .

## Section 4.2

1.
 

(a) $c_1 = 7$ ; and $c_{n+1} = c_n + 7$ , for $n \geq 1$ .	(d) $c_1 = 7$ ; and $c_{n+1} = c_n$ , for $n \geq 1$ .
(b) $c_1 = 7$ ; and $c_{n+1} = 7c_n$ , for $n \geq 1$ .	(e) $c_1 = 1$ ; and $c_{n+1} = c_n + 2n + 1$ , for $n \geq 1$ .
(c) $c_1 = 10$ ; and $c_{n+1} = c_n + 3$ , for $n \geq 1$ .	(f) $c_1 = 3, c_2 = 1$ ; and $c_{n+2} = c_n$ , for $n \geq 1$ .

2. (a) For any statements  $p_1, p_2, \dots, p_n, p_{n+1}$ , we define

- (1) the disjunction of  $p_1, p_2$  as  $p_1 \vee p_2$ ; and  
 (2) the disjunction of  $p_1, p_2, \dots, p_n, p_{n+1}$  by  $p_1 \vee p_2 \vee \dots \vee p_n \vee p_{n+1} \iff (p_1 \vee p_2 \vee \dots \vee p_n) \vee p_{n+1}$ .

(b) The result is true for  $n = 3$ . This is the Associative Law of  $\vee$  of Section 2.2.

Now assume the truth of the result for  $n = k \geq 3$  and all  $1 \leq r < k$ , that is,

$$(p_1 \vee p_2 \vee \dots \vee p_r) \vee (p_{r+1} \vee \dots \vee p_k) \iff (p_1 \vee p_2 \vee \dots \vee p_r \vee p_{r+1} \vee \dots \vee p_k).$$

When we consider the case for  $n = k + 1$  we must account for all  $1 \leq r < k + 1$ .

1) If  $r = k$ , then  $(p_1 \vee p_2 \vee \dots \vee p_k) \vee p_{k+1} \iff p_1 \vee p_2 \vee \dots \vee p_k \vee p_{k+1}$ , from our recursive definition.

2) For  $1 \leq r < k$ , we have  $(p_1 \vee p_2 \vee \dots \vee p_r) \vee (p_{r+1} \vee \dots \vee p_k \vee p_{k+1}) \iff (p_1 \vee p_2 \vee \dots \vee p_r) \vee [(p_{r+1} \vee \dots \vee p_k) \vee p_{k+1}] \iff [(p_1 \vee p_2 \vee \dots \vee p_r) \vee (p_{r+1} \vee \dots \vee p_k)] \vee p_{k+1} \iff (p_1 \vee p_2 \vee \dots \vee p_r \vee p_{r+1} \vee \dots \vee p_k) \vee p_{k+1} \iff p_1 \vee p_2 \vee \dots \vee p_r \vee p_{r+1} \vee \dots \vee p_k \vee p_{k+1}$ .

So the result is true for all  $n \geq 3$  by the Principle of Mathematical Induction.

3. For  $n \in \mathbf{Z}^+$ ,  $n \geq 2$ , let  $T(n)$  denote the (open) statement: For the statements  $p, q_1, q_2, \dots, q_n$ ,  $p \vee (q_1 \wedge \dots \wedge q_n) \iff (p \vee q_1) \wedge (p \vee q_2) \wedge \dots \wedge (p \vee q_n)$ .

The statement  $T(2)$  is true by virtue of the Distributive Law of  $\vee$  over  $\wedge$ . Assuming  $T(k)$ , for  $k \geq 2$ , we now examine the situation for the statements  $p, q_1, q_2, \dots, q_k, q_{k+1}$ .

We find that  $p \vee (q_1 \wedge q_2 \wedge \dots \wedge q_k \wedge q_{k+1}) \iff p \vee [(q_1 \wedge q_2 \wedge \dots \wedge q_k) \wedge q_{k+1}] \iff [p \vee (q_1 \wedge q_2 \wedge \dots \wedge q_k)] \wedge (p \vee q_{k+1}) \iff [(p \vee q_1) \wedge (p \vee q_2) \wedge \dots \wedge (p \vee q_k)] \wedge (p \vee q_{k+1}) \iff (p \vee q_1) \wedge (p \vee q_2) \wedge \dots \wedge (p \vee q_k) \wedge (p \vee q_{k+1})$ . It then follows by the Principle of Mathematical Induction that the statement  $T(n)$  is true for all  $n \geq 2$ .

4. (a) For  $n = 2$ , the result is simply the DeMorgan Law  $\neg(p_1 \vee p_2) \iff \neg p_1 \wedge \neg p_2$ . Assuming the truth of the result for  $n = k$ , we find for  $n = k + 1$  that  $\neg(p_1 \vee p_2 \vee \dots \vee p_k \vee p_{k+1}) \iff \neg[(p_1 \vee p_2 \vee \dots \vee p_k) \vee p_{k+1}] \iff \neg(p_1 \vee p_2 \vee \dots \vee p_k) \wedge \neg p_{k+1} \iff (\neg p_1 \wedge \neg p_2 \wedge \dots \wedge \neg p_k) \wedge \neg p_{k+1} \iff \neg p_1 \wedge \neg p_2 \wedge \dots \wedge \neg p_k \wedge \neg p_{k+1}$ , so the result is true for all  $n \geq 2$ , by the Principle of Mathematical Induction.  
 (b) This result can be obtained from part (a) by a similar argument, or by the Principle of Duality for statements.

5. (a) (i) The intersection of  $A_1, A_2$  is  $A_1 \cap A_2$ .

(ii) The intersection of  $A_1, A_2, \dots, A_n, A_{n+1}$  is given by  $A_1 \cap A_2 \cap \dots \cap A_n \cap A_{n+1} = (A_1 \cap A_2 \cap \dots \cap A_n) \cap A_{n+1}$ , the intersection of the two sets:  $A_1 \cap A_2 \cap \dots \cap A_n$  and  $A_{n+1}$ .

(b) Let  $S(n)$  denote the given (open) statement. Then the truth of  $S(3)$  follows from the Associative Law of  $\cap$ . Assuming  $S(k)$  true for some  $k \geq 3$  and all  $1 \leq r < k$ , consider the case for  $k + 1$  sets. Then we find that

1) For  $r = k$  we have  $(A_1 \cap A_2 \cap \dots \cap A_k) \cap A_{k+1} = A_1 \cap A_2 \cap \dots \cap A_k \cap A_{k+1}$ . This follows from the given recursive definition.

2) For  $1 \leq r < k$  we have  $(A_1 \cap A_2 \cap \dots \cap A_r) \cap (A_{r+1} \cap \dots \cap A_k \cap A_{k+1}) = (A_1 \cap A_2 \cap \dots \cap A_r) \cap [(A_{r+1} \cap \dots \cap A_k) \cap A_{k+1}] = [(A_1 \cap A_2 \cap \dots \cap A_r) \cap (A_{r+1} \cap \dots \cap A_k)] \cap A_{k+1} = (A_1 \cap A_2 \cap \dots \cap A_r \cap A_{r+1} \cap \dots \cap A_k) \cap A_{k+1} = A_1 \cap A_2 \cap \dots \cap A_r \cap A_{r+1} \cap \dots \cap A_k \cap A_{k+1}$ . So by the Principle of Mathematical Induction,  $S(n)$  is true for all  $n \geq 3$ .

6. (i) For  $n = 2$ , the result follows from the DeMorgan Laws. Assuming the result for  $n = k \geq 2$ , consider the case for  $k + 1$  sets  $A_1, A_2, \dots, A_k, A_{k+1}$ . Then  $\overline{A_1 \cap A_2 \cap \dots \cap A_k \cap A_{k+1}} = \overline{(A_1 \cap A_2 \cap \dots \cap A_k) \cap A_{k+1}} = \overline{(A_1 \cap A_2 \cap \dots \cap A_k)} \cup \overline{A_{k+1}} = \overline{A_1} \cup \overline{A_2} \cup \dots \cup \overline{A_k} \cup \overline{A_{k+1}} = \overline{A_1 \cup A_2 \cup \dots \cup A_k \cup A_{k+1}}$ , and the result is true for all  $n \geq 2$ , by the Principle of Mathematical Induction.

(ii) The proof for this result is similar to the one in part (i). - Simply replace each occurrence of  $\cap$  by  $\cup$ , and vice versa. (We can also obtain (ii) from (i) by invoking the Principle of Duality - Theorem 3.5.)

7. For  $n = 2$ , the truth of the result  $A \cap (B_1 \cup B_2) = (A \cap B_1) \cup (A \cap B_2)$  follows by virtue of the Distributive Law of  $\cap$  over  $\cup$ .

Assuming the result for  $n = k$ , let us examine the case for the sets  $A, B_1, B_2, \dots, B_k, B_{k+1}$ . We have  $A \cap (B_1 \cup B_2 \cup \dots \cup B_k \cup B_{k+1}) = A \cap [(B_1 \cup B_2 \cup \dots \cup B_k) \cup B_{k+1}] = [A \cap (B_1 \cup B_2 \cup \dots \cup B_k)] \cup (A \cap B_{k+1}) = [(A \cap B_1) \cup (A \cap B_2) \cup \dots \cup (A \cap B_k)] \cup (A \cap B_{k+1}) = (A \cap B_1) \cup (A \cap B_2) \cup \dots \cup (A \cap B_k) \cup (A \cap B_{k+1})$ .

8. (a) (i) For  $n = 2$ ,  $x_1 + x_2$  denotes the ordinary sum of the real numbers  $x_1$  and  $x_2$ .

(ii) For real numbers  $x_1, x_2, \dots, x_n, x_{n+1}$ , we have  $x_1 + x_2 + \dots + x_n + x_{n+1} = (x_1 + x_2 + \dots + x_n) + x_{n+1}$ , the sum of the *two* real numbers  $x_1 + x_2 + \dots + x_n$  and  $x_{n+1}$ .

(b) The truth of this result for  $n = 3$  follows from the Associative Law of Addition - since  $x_1 + (x_2 + x_3) = (x_1 + x_2) + x_3$ , there is no ambiguity in writing  $x_1 + x_2 + x_3$ .

Assuming the result true for all  $k \geq 3$  and all  $1 \leq r < k$ , let us examine the case for  $k + 1$  real numbers. We find that

1) When  $r = k$  we have  $(x_1 + x_2 + \dots + x_r) + x_{r+1} = x_1 + x_2 + \dots + x_r + x_{r+1}$ , by virtue of the recursive definition.

2) For  $1 \leq r < k$  we have  $(x_1 + x_2 + \dots + x_r) + (x_{r+1} + \dots + x_k + x_{k+1}) = (x_1 + x_2 + \dots + x_r) + [(x_{r+1} + \dots + x_k) + x_{k+1}] = [(x_1 + x_2 + \dots + x_r) + (x_{r+1} + \dots + x_k)] + x_{k+1} = (x_1 + x_2 + \dots + x_r + x_{r+1} + \dots + x_k) + x_{k+1} = x_1 + x_2 + \dots + x_r + x_{r+1} + \dots + x_k + x_{k+1}$ . So the result is true for all  $n \geq 3$  and all  $1 \leq r < n$ , by the Principle of Mathematical Induction.

9. a) (i) For  $n = 2$ , the expression  $x_1 x_2$  denotes the ordinary product of the real numbers  $x_1$  and  $x_2$ .

(ii) Let  $n \in \mathbf{Z}^+$  with  $n \geq 2$ . For the real numbers  $x_1, x_2, \dots, x_n, x_{n+1}$ , we define

$$x_1 x_2 \cdots x_n x_{n+1} = (x_1 x_2 \cdots x_n) x_{n+1},$$

the product of the *two* real numbers  $x_1 x_2 \cdots x_n$  and  $x_{n+1}$ .

b) The result holds for  $n = 3$  by the Associative Law of Multiplication (for real numbers). So  $x_1(x_2 x_3) = (x_1 x_2)x_3$ , and there is no ambiguity in writing  $x_1 x_2 x_3$ .

Assuming the result true for some (particular)  $k \geq 3$  and all  $1 \leq r < k$ , let us examine the case for  $k + 1$  ( $\geq 4$ ) real numbers. We find that

1) When  $r = k$  we have

$$(x_1 x_2 \cdots x_r) x_{r+1} = x_1 x_2 \cdots x_r x_{r+1}$$

by virtue of the recursive definition.

2) For  $1 \leq r < k$  we have

$$\begin{aligned} (x_1 x_2 \cdots x_r)(x_{r+1} \cdots x_k x_{k+1}) &= (x_1 x_2 \cdots x_r)((x_{r+1} \cdots x_k)x_{k+1}) \\ &= ((x_1 x_2 \cdots x_r)(x_{r+1} \cdots x_k))x_{k+1} = (x_1 x_2 \cdots x_r x_{r+1} \cdots x_k)x_{k+1} \\ &= x_1 x_2 \cdots x_r x_{r+1} \cdots x_k x_{k+1}, \end{aligned}$$

so the result is true for all  $n \geq 3$  and all  $1 \leq r < n$ , by the Principle of Mathematical Induction.

10. The result is true for  $n = 2$  by the material presented at the start of the problem. Assuming the truth for  $n = k$  real numbers, we have, for  $n = k + 1$ ,  $|x_1 + x_2 + \cdots + x_k + x_{k+1}| = |(x_1 + x_2 + \cdots + x_k) + x_{k+1}| \leq |x_1 + x_2 + \cdots + x_k| + |x_{k+1}| \leq |x_1| + |x_2| + \cdots + |x_k| + |x_{k+1}|$ , so the result is true for all  $n \geq 2$  by the Principle of Mathematical Induction.

11. Proof: (By the Alternative Form of the Principle of Mathematical Induction)

For  $n = 0, 1, 2$  we have

$$(n = 0) \quad a_{0+2} = a_2 = 1 \geq (\sqrt{2})^0;$$

$$(n = 1) \quad a_{1+2} = a_3 = a_2 + a_0 = 2 \geq \sqrt{2} = (\sqrt{2})^1; \text{ and}$$

$$(n = 2) \quad a_{2+2} = a_4 = a_3 + a_1 = 2 + 1 = 3 \geq 2 = (\sqrt{2})^2.$$

Therefore the result is true for these first three cases, and this gives us the basis step for the proof.

Next, for some  $k \geq 2$  we assume the result true for all  $n = 0, 1, 2, \dots, k$ . When  $n = k + 1$  we find that

$$\begin{aligned} a_{(k+1)+2} = a_{k+3} = a_{k+2} + a_k &\geq (\sqrt{2})^k + (\sqrt{2})^{k-2} = [(\sqrt{2})^2 + 1](\sqrt{2})^{k-2} = 3(\sqrt{2})^{k-2} \\ &= (3/2)(2)(\sqrt{2})^{k-2} = (3/2)(\sqrt{2})^k \geq (\sqrt{2})^{k+1}, \text{ because } (3/2) = 1.5 > \sqrt{2} (\doteq 1.414). \end{aligned}$$

This provides the inductive step for the proof.

From the basis and inductive steps it now follows by the Alternative Form of the Principle of Mathematical Induction that  $a_{n+2} \geq (\sqrt{2})^n$  for all  $n \in \mathbf{N}$ .

12. Proof: (By Mathematical Induction)

We find that  $F_0 = \sum_{i=0}^0 F_i = 0 = 1 - 1 = F_2 - 1$ , so the given statement holds in this first case — and this provides the basis step of the proof.

For the inductive step we assume the truth of the statement when  $n = k (\geq 0)$  — that is,

that  $\sum_{i=0}^k F_i = F_{k+2} - 1$ . Now we consider what happens when  $n = k + 1$ . We find for this case that

$$\sum_{i=0}^{k+1} F_i = \left( \sum_{i=0}^k F_i \right) + F_{k+1} = (F_{k+2} - 1) + F_{k+1} = (F_{k+2} + F_{k+1}) - 1 = F_{k+3} - 1,$$

so the truth of the statement at  $n = k$  implies the truth at  $n = k + 1$ .

Consequently,  $\sum_{i=0}^n F_i = F_{n+2} - 1$  for all  $n \in \mathbf{N}$  — by the Principle of Mathematical Induction.

13. Proof: (By Mathematical Induction).

Basis Step: When  $n = 1$  we find that

$$\sum_{i=1}^1 \frac{F_{i-1}}{2^i} = F_0/2 = 0 = 1 - (2/2) = 1 - \frac{F_3}{2} = 1 - \frac{F_{1+2}}{2^1},$$

so the result holds in the first case.

Inductive Step: Assuming the given (open) statement for  $n = k$ , we have  $\sum_{i=1}^k \frac{F_{i-1}}{2^i} = 1 - \frac{F_{k+2}}{2^k}$ .

When  $n = k + 1$ , we find that

$$\begin{aligned} \sum_{i=1}^{k+1} \frac{F_{i-1}}{2^i} &= \sum_{i=1}^k \frac{F_{i-1}}{2^i} + \frac{F_k}{2^{k+1}} = 1 - \frac{F_{k+2}}{2^k} + \frac{F_k}{2^{k+1}} \\ &= 1 + (1/2^{k+1})[F_k - 2F_{k+2}] = 1 + (1/2^{k+1})[(F_k - F_{k+2}) - F_{k+2}] \\ &= 1 + (1/2^{k+1})[-F_{k+1} - F_{k+2}] = 1 - (1/2^{k+1})(F_{k+1} + F_{k+2}) = 1 - (F_{k+3}/2^{k+1}). \end{aligned}$$

From the basis and inductive steps it follows from the Principle of Mathematical Induction that

$$\forall n \in \mathbf{Z}^+ \sum_{i=1}^n (F_{i-1}/2^i) = 1 - (F_{n+2}/2^n).$$

14. Proof: (By Mathematical Induction)

For  $n = 1$  we find

$$L_1^2 = 1^2 = 1 = (1)(3) - 2 = L_1 L_2 - 2,$$

so the result holds in this first case.

Next we assume the result is true when  $n = k$ . This gives us  $\sum_{i=1}^k L_i^2 = L_k L_{k+1} - 2$ . Then

$$\begin{aligned} \text{for } n = k + 1 \text{ we find that } \sum_{i=1}^{k+1} L_i^2 &= \sum_{i=1}^k L_i^2 + L_{k+1}^2 = L_k L_{k+1} - 2 + L_{k+1}^2 = L_k L_{k+1} + L_{k+1}^2 - 2 \\ &= L_{k+1}(L_k + L_{k+1}) - 2 = L_{k+1} L_{k+2} - 2. \end{aligned}$$

Consequently, by the Principle of Mathematical Induction, it follows that

$$\forall n \in \mathbf{Z}^+ \sum_{i=1}^n L_i^2 = L_n L_{n+1} - 2.$$

15. Proof: (By the Alternative Form of the Principle of Mathematical Induction)

The result holds for  $n = 0$  and  $n = 1$  because

$$(n = 0) \quad 5F_{0+2} = 5F_2 = 5(1) = 5 = 7 - 2 = L_4 - L_0 = L_{0+4} - L_0; \text{ and}$$

$$(n = 1) \quad 5F_{1+2} = 5F_3 = 5(2) = 10 = 11 - 1 = L_5 - L_1 = L_{1+4} - L_1.$$

This establishes the basis step for the proof.

Next we assume the induction hypothesis — that is, that for some  $k (\geq 1)$ ,  $5F_{n+2} = L_{n+4} - L_n$  for all  $n = 0, 1, 2, \dots, k-1, k$ . It then follows that for  $n = k + 1$ ,

$5F_{(k+1)+2} = 5F_{k+3} = 5(F_{k+2} + F_{k+1}) = 5(F_{k+2} + F_{(k-1)+2})$   
 $= 5F_{k+2} + 5F_{(k-1)+2} = (L_{k+4} - L_k) + (L_{(k-1)+4} - L_{k-1}) = (L_{k+4} - L_k) + (L_{k+3} - L_{k-1})$   
 $= (L_{k+4} + L_{k+3}) - (L_k + L_{k-1}) = L_{k+5} - L_{k+1} = L_{(k+1)+4} - L_{k+1}$  — where we have used the recursive definitions of the Fibonacci numbers and Lucas numbers to establish the second and eighth equalities.

It then follows by the Alternative Form of the Principle of Mathematical Induction that

$$\forall n \in \mathbf{N} \quad 5F_{n+2} = L_{n+4} - L_n.$$

16. (a) Let  $E$  denote the set of all positive even integers. We define  $E$  recursively by
- (1)  $2 \in E$ ; and
  - (2) For each  $n \in E$ ,  $n + 2 \in E$ .
- (b) If  $G$  denotes the set of all nonnegative even integers we define  $G$  recursively by
- (1)  $0 \in G$ ; and
  - (2) For each  $m \in G$ ,  $m + 2 \in G$ .

17.

(a)	<b>Steps</b>	<b>Reasons</b>
	(1) $p, q, r, T_0$	Part (1) of the definition
	(2) $(p \vee q)$	Step (1) and Part (2-ii) of the definition
	(3) $(\neg r)$	Step (1) and Part (2-i) of the definition
	(4) $(T_0 \wedge (\neg r))$	Steps (1), (3), and Part (2-iii) of the definition
	(5) $((p \vee q) \rightarrow (T_0 \wedge (\neg r)))$	Steps (2), (4), and Part (2-iv) of the definition
(b)	<b>Steps</b>	<b>Reasons</b>
	(1) $p, q, r, s, F_0$	Part (1) of the definition
	(2) $(\neg p)$	Step (1) and Part (2-i) of the definition
	(3) $((\neg p) \leftrightarrow q)$	Steps (1), (2), and Part (2-v) of the definition
	(4) $(s \vee F_0)$	Step (1) and Part (2-ii) of the definition
	(5) $(r \wedge (s \vee F_0))$	Steps (1), (4), and Part (2-iii) of the definition
	(6) $((\neg p) \leftrightarrow q) \rightarrow (r \wedge (s \vee F_0))$	Steps (3), (5), and Part (2-iv) of the definition

18.

(a)	$k = 0:$	1	321
	$k = 1:$	4	132, 213, 231, 312
	$k = 2:$	1	123
(b)	$k = 0:$	1	4321
	$k = 1:$	11	1432, 2143, 2431, 3142, 3214, 3241, 3421, 4132, 4213, 4231, 4312
	$k = 2:$	11	1243, 1324, 1342, 1423, 2134, 2314, 2341, 2413, 3124, 3412, 4123
	$k = 3:$	1	1 2 3 4
(c)	Two descents		

(d)  $(m-1) - k = m - k - 1$  descents.

(e) (i) Five locations: (1) In front of 1; (2) Between 1,2; (3) Between 2,4; (4) Between 3,6; (5) Between 5,8. [The five locations are determined by the four ascents and the one location at the start (in front of 1) of  $p$ .]

(ii) Four locations: (1) Between 4,3; (2) Between 6,5; (3) Between 8,7; (4) Following 7. [The four locations are determined by the three descents and the one location at the end (following 7) of  $p$ .]

$$(f) \pi_{m,k} = (k+1)\pi_{m-1,k} + (m-k)\pi_{m-1,k-1}.$$

Let  $x : x_1, x_2, \dots, x_m$  denote a permutation of  $1, 2, 3, \dots, m$  with  $k$  ascents (and  $m - k - 1$  descents). (1) If  $m = x_m$  or if  $m$  occurs in  $x_i m x_{i+2}$ ,  $1 \leq i \leq m-2$ , with  $x_i > x_{i+2}$  then the removal of  $m$  results in a permutation of  $1, 2, 3, \dots, m-1$  with  $k-1$  ascents - for a total of  $[1 + (m-k-1)]\pi_{m-1,k-1} = (m-k)\pi_{m-1,k-1}$  permutations. (2) If  $m = x_1$  or if  $m$  occurs in  $x_i m x_{i+2}$ ,  $1 \leq i \leq m-2$ , with  $x_i < x_{i+2}$ , then the removal of  $m$  results in a permutation of  $1, 2, 3, \dots, m-1$  with  $k$  ascents - for a total of  $(k+1)\pi_{m-1,k}$  permutations.

Since cases (1) and (2) have nothing in common and account for all possibilities the recursive formula for  $\pi_{m,k}$  follows. [Note: These are the Eulerian numbers  $a_{m,k}$  of Example 4.21.]

$$19. (a) \binom{k}{2} + \binom{k+1}{2} = [k(k-1)/2] + [(k+1)k/2] = (k^2 - k + k^2 + k)/2 = k^2.$$

$$(c) \binom{k}{3} + 4\binom{k+1}{3} + \binom{k+2}{3} = [k(k-1)(k-2)/6] + 4[(k+1)(k)(k-1)/6] + [(k+2)(k+1)(k)/6] = (k/6)[(k-1)(k-2) + 4(k+1)(k-1) + (k+2)(k+1)] = (k/6)[6k^2] = k^3.$$

$$(d) \sum_{k=1}^n k^3 = \sum_{k=1}^n \binom{k}{3} + 4 \sum_{k=1}^n \binom{k+1}{3} + \sum_{k=1}^n \binom{k+2}{3} = \binom{n+1}{4} + 4\binom{n+2}{4} + \binom{n+3}{4} = (1/24)[(n+1)(n)(n-1)(n-2) + 4(n+2)(n+1)(n)(n-1) + (n+3)(n+2)(n+1)(n)] = [(n+1)(n)/24][(n-1)(n-2) + 4(n+2)(n-1) + (n+3)(n+2)] = [(n+1)(n)/24][6n^2 + 6n] = n^2(n+1)^2/4.$$

$$(e) k^4 = \binom{k}{4} + 11\binom{k+1}{4} + 11\binom{k+2}{4} + \binom{k+3}{4}$$

In general,  $k^t = \sum_{r=0}^{t-1} a_{t,r} \binom{k+r}{t}$ , where the  $a_{t,r}$ 's are the Eulerian numbers of Example 4.21. [The given summation formula is known as Worpitzky's identity.]

20. (a) For  $n = 2$ ,  $[(p_1 \rightarrow p_2) \wedge (p_2 \rightarrow p_3)] \Rightarrow [(p_1 \wedge p_2) \rightarrow p_3]$ , for if  $(p_1 \wedge p_2) \rightarrow p_3$  has value 0, then  $p_1$  and  $p_2$  have value 1 and  $p_3$  has value 0. But then  $p_2 \rightarrow p_3$  and  $(p_1 \rightarrow p_2) \wedge (p_2 \rightarrow p_3)$  both have value 0. Assume the result for  $n = k-1$ , and consider the case of  $n = k$ . Then  $[(p_1 \rightarrow p_2) \wedge (p_2 \rightarrow p_3) \wedge \dots \wedge (p_{k-1} \rightarrow p_k) \wedge (p_k \rightarrow p_{k+1})] \Rightarrow [((p_1 \wedge p_2 \wedge \dots \wedge p_{k-1}) \rightarrow p_k) \wedge (p_k \rightarrow p_{k+1})] \Rightarrow [(p_1 \wedge p_2 \wedge \dots \wedge p_k) \rightarrow p_{k+1}]$ .

(b) Suppose that  $S(1)$  is true and that if  $S(k)$  is true for some  $k \in \mathbb{Z}^+$ , then  $S(k) \Rightarrow S(k+1)$ . Then we find that  $[S(1) \Rightarrow S(2), S(2) \Rightarrow S(3), \dots, S(k) \Rightarrow S(k+1)]$  and by part (a),  $[(S(1) \wedge S(2) \wedge \dots \wedge S(k)) \Rightarrow S_{k+1}]$ . So by Theorem 4.2,  $S(n)$  is true for all  $n$ . Hence Theorem 4.2 implies Theorem 4.1.

(c) If  $n = 1$  the result follows. Assume the result for  $n = k (\geq 1)$ , for some  $k \in \mathbb{Z}^+$  and consider the case for  $n = k+1$ . If  $1 \in S$  then the result follows. If  $1 \notin S$ , let

$T = \{x - 1 | x \in S\} \neq \emptyset$ . Then  $k \in T$  and by applying the induction hypothesis to  $T$ ,  $T$  has a least element  $t \geq 1$  and  $S$  has a least element  $t + 1 \geq 2$ .

(d) From part (c), Theorem 4.1 implies the Well-Ordering Principle. In the solution of Exercise 27 of Section 4.1 the Well-Ordering Principle implies Theorem 4.2. Hence Theorem 4.1 implies Theorem 4.2.

### Section 4.3

1. (a)  $a = a \cdot 1$ , so  $1|a$ ;  $0 = a \cdot 0$ , so  $a|0$ .  
 (b)  $a|b \implies b = ac$ , for some  $c \in \mathbf{Z}$ .  $b|a \implies a = bd$ , for some  $d \in \mathbf{Z}$ . So  $b = ac = b(dc)$  and  $d = c = 1$  or  $-1$ . Hence  $a = b$  or  $a = -b$ .  
 (c)  $a|b \implies b = ax$ ,  $b|c \implies c = by$ , for some  $x, y \in \mathbf{Z}$ . So  $c = by = a(xy)$  and  $a|c$ .  
 (d)  $a|b \implies ac = b$ , for some  $c \in \mathbf{Z} \implies acx = bx \implies a|bx$ .  
 (e) If  $a|x$ ,  $a|y$  then  $x = ac$ ,  $y = ad$  for some  $c, d \in \mathbf{Z}$ . So  $z = x - y = a(c - d)$ , and  $a|z$ . The proofs for the other cases are similar.  
 (g) Follows from part (f) by the Principle of Mathematical Induction.
2. (a)  $a|b \implies ax = b$ , for some  $x \in \mathbf{Z}^+$ ;  $c|d \implies cy = d$ , for some  $y \in \mathbf{Z}^+$ . Then  $(ac)(xy) = bd$ , so  $ac|bd$ .  
 (c)  $ac|bc \implies acx = bc$ , for some  $x \in \mathbf{Z}^+ \implies (ax - b)c = 0 \implies [ax - b = 0$ , since  $c > 0] \implies ax = b \implies a|b$ .  
 The proof for part (b) is similar.
3. Since  $q$  is prime its only positive divisors are 1 and  $q$ . With  $p$  a prime,  $p > 1$ . Hence  $p|q \implies p = q$ .
4. No.  $6|(2 \cdot 3)$  but  $6 \nmid 2$  and  $6 \nmid 3$ .
5. Proof: (By the Contrapositive)  
 Suppose that  $a \nmid b$  or  $a \nmid c$ .  
 If  $a \nmid b$ , then  $ak = b \nexists k \in \mathbf{Z}$ . But  $ak = b \implies (ak)c = a(kc) = bc \implies a | bc$ .  
 A similar result is obtained if  $a \nmid c$ .
6. Proof: (By Mathematical Induction)  
 The result for  $n = 2$  is true by virtue of part (a) of Exercise 2. So assume the result for  $n = k (\geq 2)$ . Then consider the case for  $n = k + 1$ : We have positive integers  $a_1, a_2, \dots, a_k, a_{k+1}, b_1, b_2, \dots, b_k, b_{k+1}$ , where  $a_i|b_i$  for all  $1 \leq i \leq k + 1$ . If we let  $a = a_1 a_2 \cdots a_k$  and  $b = b_1 b_2 \cdots b_k$ , then we know that  $a|b$  by the induction hypothesis. And since  $a|b$  and  $a_{k+1}|b_{k+1}$ , by the case for  $n = 2$ , it follows that  $a \cdot a_{k+1}|b \cdot b_{k+1}$ , or  $(a_1 \cdot a_2 \cdots a_k \cdot a_{k+1})|(b_1 \cdot b_2 \cdots b_k \cdot b_{k+1})$ .  
 Therefore the result is true for all  $n \geq 2$  — by the Principle of Mathematical Induction.
7. a) Let  $a = 1, b = 5, c = 2$ . Another example is  $a = b = 5, c = 3$ .

b) Proof:

$31|(5a + 7b + 11c) \implies 31|(10a + 14b + 22c)$ . Also,  $31|(31a + 31b + 31c)$ , so  $31|[(31a + 31b + 31c) - (10a + 14b + 22c)]$ . Hence  $31|(21a + 17b + 9c)$ .

8. Note that each of Eleanor's 12 numbers is divisible by 6. Consequently, every sum that uses any of these numbers must also be divisible by 6 (because of part (g) of Theorem 4.3 - where each  $x_i = 1$ , for  $1 \leq i \leq n$ ). Unfortunately 500 is not divisible by 6, so Eleanor has not received a winning card.
9.  $b|a, b|(a + 2) \implies b|[ax + (a + 2)y]$  for all  $x, y \in \mathbb{Z}$ . Let  $x = -1, y = 1$ . Then  $b > 0$  and  $b|2$ , so  $b = 1$  or  $2$ .
10. Let  $n = 2k + 1, k \geq 0$ .  $n^2 - 1 = (2k + 1)^2 - 1 = 4k^2 + 4k = 4k(k + 1)$ . Since one of  $k, k + 1$  must be even, it follows that  $8|(n^2 - 1)$ .
11. Let  $a = 2m + 1, b = 2n + 1$ , for some  $m, n \geq 0$ . Then  $a^2 + b^2 = 4(m^2 + m + n^2 + n) + 2$ , so  $2|(a^2 + b^2)$  but  $4 \nmid (a^2 + b^2)$ .
12. (a)  $23 = 3 \cdot 7 + 2, \quad q = 3, r = 2$ .  
(b)  $-115 = (-10) \cdot 12 + 5, \quad q = -10, r = 5$ .  
(c)  $0 = 0 \cdot 42 + 0, \quad q = 0, r = 0$ .  
(d)  $434 = 14 \cdot 31 + 0, \quad q = 14, r = 0$ .
13. Proof:  
For  $n = 0$  we have  $7^n - 4^n = 7^0 - 4^0 = 1 - 1 = 0$ , and  $3|0$ . So the result is true for this first case. Assuming the truth for  $n = k$  we have  $3|(7^k - 4^k)$ . Turning to the case for  $n = k + 1$  we find that  $7^{k+1} - 4^{k+1} = 7(7^k) - 4(4^k) = (3 + 4)(7^k) - 4(4^k) = 3(7^k) + 4(7^k - 4^k)$ . Since  $3|3$  and  $3|(7^k - 4^k)$  (by the induction hypothesis), it follows from part (f) of Theorem 4.3 that  $3|[3(7^k) + 4(7^k - 4^k)]$ , that is,  $3|(7^{k+1} - 4^{k+1})$ . It now follows by the Principle of Mathematical Induction that  $3|(7^n - 4^n)$  for all  $n \in \mathbb{N}$ .
14. (a)  $137 = (10001001)_2 = (2021)_4 = (211)_8$   
(b)  $6243 = (1100001100011)_2 = (1201203)_4 = (14143)_8$   
(c)  $12,345 = (11000000111001)_2 = (3000321)_4 = (30071)_8$

15.

	Base 10	Base 2	Base 16
(a)	22	10110	16
(b)	527	1000001111	20F
(c)	1234	10011010010	4D2
(d)	6923	1101100001011	1B0B

	Base 16	Base 2	Base 10
16. (a)	A7	10100111	167
(b)	4C2	10011000010	1218
(c)	1CB2	1110010110010	7346
(d)	A2DFE	10100010110111111110	667134

	Base 2	Base 10	Base 16
17. (a)	11001110	206	CE
(b)	00110001	49	31
(c)	11110000	240	F0
(d)	01010111	87	57

18. The base 7.

19. Here  $n$  is a divisor of 18 – so  $n \in \{1, 2, 3, 6, 9, 18\}$ .

20. (a) 00001111                      (b) 11110001                      (c) 01100100  
 (d) Start with the binary representation of 65

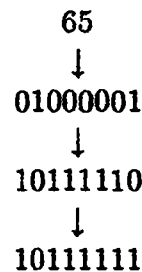

Interchanges the 0's and 1's to obtain the one's complement

Add 1 to the one's complement

- (e) 01111111                      (f) 10000000

21.

	Largest Integer	Smallest Integer
(a)	$7 = 2^3 - 1$	$-8 = -(2^3)$
(b)	$127 = 2^7 - 1$	$-128 = -(2^7)$
(c)	$2^{15} - 1$	$-(2^{15})$
(d)	$2^{31} - 1$	$-(2^{31})$
(e)	$2^{n-1} - 1$	$-(2^{n-1})$

22.

(a)	0101 (= 5)	(b)	1101 (= -3)
	<u>+0001</u> (= 1)		<u>+1110</u> (= -2)
	0110 (= 6)		1011 (= -5)
(c)	0111 (= 7)	(d)	1101 (= -3)
	<u>+1000</u> (= -8)		<u>+1010</u> (= -6)
	1111 (= -1)		0111 ( $\neq$ -9) (overflow error)

23.  $ax = ay \implies ax - ay = 0 \implies a(x - y) = 0$ . In the system of integers, if  $b, c \in \mathbb{Z}$  and  $bc = 0$ , then  $b = 0$  or  $c = 0$ . Since  $a(x - y) = 0$  and  $a \neq 0$  then  $(x - y) = 0$  and  $x = y$ .

24.

```

Program ChangeOfBase (Input,Output);
Var Number, Base, Remainder,
    Power, Result, Keep : Integer;
Begin
    Writeln ('Input the base 10 number - positive integer - that is to be changed.');
```

Write ('Number = ');  
 Read (Number);  
 Writeln ('Input the base - an integer between 2 and 9 inclusive.');

Write (' Base = ');  
 Read (Base);  
 Keep := Number;  
 Result := 0;  
 Power := 1;

While Number > 0 Do  
 Begin  
 Remainder := Number Mod Base;  
 Result := Result + (Remainder \* Power);  
 Power := Power \* 10;  
 Number := Number Div Base

End;

Writeln ('The number ', Keep:0, 'when converted to',  
 'base ', Base:0, 'is written as ', Result:0)

End.

25. (i) If  $a = 0$ , choose  $q = r = 0$ .  
 (ii) Let  $a > 0, b < 0$ . Then  $-b > 0$  so there exist  $q, r \in \mathbf{Z}$  with  $a = q(-b) + r$ , where  $0 \leq r < (-b)$ . Hence  $a = (-q)b + r$  with  $0 \leq r < |b|$ .  
 (iii) Finally, consider the case where  $a < 0$  and  $b < 0$ . Then  $-a, -b > 0$  so  $-a = q'(-b) + r'$  with  $0 \leq r' < (-b)$ . So  $a = q'b - r' = (q' + 1)b + (-r' - b) = qb + r$  with  $0 \leq r = -b - r' < -b = |b|$ .
- For uniqueness, let  $a, b \in \mathbf{Z}, b \neq 0$ , and assume  $a = q_1b + r_1 = q_2b + r_2$ , where  $0 \leq r_1, r_2 \leq |b|$ . Then  $0 = (q_1 - q_2)b + (r_1 - r_2)$  and  $|q_1 - q_2||b| = |r_1 - r_2|$ . If  $r_1 \neq r_2$ , then  $|r_1 - r_2| > 0$  but  $|r_1 - r_2| < |b|$ . Hence  $|q_1 - q_2||b| < |b|$ . This can only happen if  $q_1 = q_2$ . But then  $r_1 = r_2$ , so  $q, r$  are unique.

26. Program Base\_16(Input,Output);  
 (\* This program converts a positive integer less than 4,294,967,295 ( $= 16^8 - 1$ ) to base 16.\*)

```

Type
    sub1 = 0..15;
```

```

sub2 = 10..15;
sub3 = 0..8;
sub4 = -1..7;
Var
  remainders: sub1;
  larger: sub2;
  positions: array [0..7] of sub 1;
  i: sub3;
  j: sub4;
  m,n: integer;
Begin
  Writeln ('What positive integer do you wish to convert to base 16?');
  Readln (n);
  For i := 0 to 7 do
    positions [i] := 0;
  m := n;
  i := 0;
  While m > 0 do
    Begin
      positions[i] := m mod 16;
      m := m div 16;
      i := i+1
    End;
  j := i-1;
  Write ('The integer ', n:0, ' in base 16 is written ');
  While j >= 0 do
    Begin
      If positions[j] < 10 then
        Write (positions[j] : 1)
      Else
        Begin
          larger := positions[j];
          Case larger of
            10: Write ('A');
            11: Write ('B');
            12: Write ('C');
            13: Write ('D');
            14: Write ('E');
            15: Write ('F')
          End
        End;
      j := j - 1
    End;
  End;

```

```

    Writeln ('.')
End.

```

27.

```

Program Divisors (input,output);
Var
    N, Divisor: Integer;
Begin
    Write ('The positive integer N whose divisors are sought is N = ');
    Read (N);
    Writeln;
    If N = 1 Then
        Writeln ('The only divisor of 1 is 1.')
    Else
        Begin
            Writeln ('The divisors of ', N:0, ' are :');
            Writeln (1:8);
            If N Mod 2 = 0 Then
                Begin
                    For Divisor := 2 to N Div 2 Do
                        If N Mod Divisor = 0 Then
                            Writeln (Divisor:8)
                End
            Else
                For Divisor := 3 to N Div 3 Do
                    If N Mod Divisor = 0 Then
                        Writeln (Divisor:8)
                End;
            Writeln (N:8)
        End.

```

28. Proof: Let  $Y = \{3k \mid k \in \mathbb{Z}^+\}$ , the set of all positive integers divisible by 3. In order to show that  $X = Y$  we shall verify that  $X \subseteq Y$  and  $Y \subseteq X$ .

(i) ( $X \subseteq Y$ ): By part (1) of the recursive definition of  $X$  we have 3 in  $X$ . And since  $3 = 3 \cdot 1$ , it follows that 3 is in  $Y$ . Turning to part (2) of this recursive definition suppose that for  $x, y \in X$  we also have  $x, y \in Y$ . Now  $x + y \in X$  by the definition and we need to show that  $x + y \in Y$ . This follows because  $x, y \in Y \Rightarrow x = 3m, y = 3n$  for some  $m, n \in \mathbb{Z}^+ \Rightarrow x + y = 3m + 3n = 3(m + n)$ , with  $m + n \in \mathbb{Z}^+ \Rightarrow x + y \in Y$ . Therefore every positive integer that results from either part (1) or part (2) of the recursive definition of  $X$  is an element in  $Y$ , and, consequently,  $X \subseteq Y$ .

(ii) ( $Y \subseteq X$ ): In order to establish this inclusion we need to show that every positive integer multiple of 3 is in  $X$ . This will be accomplished by the Principle of Mathematical Induction.

Start with the open statement

$$S(n): 3n \text{ is an element in } X,$$

which is defined for the universe  $\mathbf{Z}^+$ . The basis step — that is,  $S(1)$  — is true because  $3 \cdot 1 = 3$  is in  $X$  by part (1) of the recursive definition of  $X$ . For the inductive step of this proof we assume the truth of  $S(k)$  for some  $k (\geq 1)$  and consider what happens at  $n = k + 1$ . From the inductive hypothesis  $S(k)$  we know that  $3k$  is in  $X$ . Then from part (2) of the recursive definition of  $X$  we find that  $3(k + 1) = 3k + 3 \in X$  because  $3k, 3 \in X$ . Hence  $S(k) \Rightarrow S(k + 1)$ . So by the Principle of Mathematical Induction it follows that  $S(n)$  is true for all  $n \in \mathbf{Z}^+$  — and, consequently,  $Y \subseteq X$ .

With  $X \subseteq Y$  and  $Y \subseteq X$  it follows that  $X = Y$ .

29. (a) Since  $2|10^t$  for all  $t \in \mathbf{Z}^+$ ,  $2|n$  iff  $2|r_0$ . (b) Follows from the fact that  $4|10^t$  for  $t \geq 2$ .  
 (c) Follows from the fact that  $8|10^t$  for  $t \geq 3$ .  
 In general,  $2^{t+1}|n$  iff  $2^{t+1}|(r_t \cdot 10^t + \cdots + r_1 \cdot 10 + r_0)$ .

#### Section 4.4

- (a)  $1820 = 7(231) + 203$   
 $231 = 1(203) + 28$   
 $203 = 7(28) + 7$   
 $28 = 7(4)$ , so  $\gcd(1820, 23) = 7$   
 $7 = 203 - 7(28) = 203 - 7[231 - 203] = (-7)(231) + 8(203) = (-7)(231) + 8[1820 - 7(231)] = 8(1820) + (-63)(231)$

(b)  $\gcd(1369, 2597) = 1 = 2597(534) + 1369(-1013)$   
 (c)  $\gcd(2689, 4001) = 1 = 4001(-1117) + 2689(1662)$
- (a) If  $as + bt = 2$ , then  $\gcd(a, b) = 1$  or  $2$ , for the  $\gcd$  of  $a, b$  divides  $a, b$  so it divides  $as + bt = 2$ .  
 (b)  $as + bt = 3 \Rightarrow \gcd(a, b) = 1$  or  $3$ .  
 (c)  $as + bt = 4 \Rightarrow \gcd(a, b) = 1, 2$  or  $4$ .  
 (d)  $as + bt = 6 \Rightarrow \gcd(a, b) = 1, 2, 3$  or  $6$ .
- $\gcd(a, b) = d \Rightarrow d = ax + by$ , for some  $x, y \in \mathbf{Z}$ .  $\gcd(a, b) = d \Rightarrow a/d, b/d \in \mathbf{Z}$ .  
 $1 = (a/d)x + (b/d)y \Rightarrow \gcd(a/d, b/d) = 1$ .
- Let  $\gcd(a, b) = g$ ,  $\gcd(na, nb) = h$ .  $\gcd(a, b) = g \Rightarrow g = as + bt$ , for some  $s, t \in \mathbf{Z}$ .  
 $ng = (na)s + (nb)t$ , so  $h|ng$ .  $h = \gcd(na, nb) \Rightarrow h = (na)x + (nb)y$ , for some  $x, y \in \mathbf{Z}$ .  
 $h = n(ax + by) \Rightarrow n|h \Rightarrow nh_1 = h$  for some  $h_1 \in \mathbf{Z}$  and  $h_1 = ax + by$ .  $g = \gcd(a, b) \Rightarrow g|h_1 \Rightarrow n(gh_2) = h$  for some  $h_2 \in \mathbf{Z}$ . Since  $(ng)|h$  and  $h|(ng)$ , with  $h, ng \in \mathbf{Z}^+$ , it follows that  $\gcd(na, nb) = h = ng = n \gcd(a, b)$ .

5. Proof: Since  $c = \gcd(a, b)$  we have  $a = cx$ ,  $b = cy$  for some  $x, y \in \mathbf{Z}^+$ . So  $ab = (cx)(cy) = c^2(xy)$ , and  $c^2$  divides  $ab$ .
6. (a)  $2 = 1(n+2) + (-1)n$ . Since  $\gcd(n, n+2)$  is the smallest positive integer that can be expressed as a linear combination of  $n$  and  $n+2$ , it follows that  $\gcd(n, n+2) \leq 2$ . Furthermore,  $\gcd(n, n+2) | 2$ . Hence  $\gcd(n, n+2) = 1$  or  $2$ . In fact,  $\gcd(n, n+2) = 1$ , for  $n$  odd, and  $\gcd(n, n+2) = 2$ , for  $n$  even.
- (b) Arguing as in part (a) we have  $\gcd(n, n+3) = 1$  or  $3$ . When  $n$  is a multiple of  $3$ , then  $\gcd(n, n+3) = 3$ ; otherwise,  $\gcd(n, n+3) = 1$ .
- For  $\gcd(n, n+4)$  we need to be cautious. The answer is not  $1$  or  $4$ . Here we have  $\gcd(n, n+4) = 1$  or  $2$  or  $4$ . For  $n$  a multiple of  $4$ ,  $\gcd(n, n+4) = 4$ . When  $n = 4t + 2$ ,  $t \in \mathbf{Z}^+$ , we find that  $\gcd(n, n+4) = 2$ . For  $n$  odd,  $\gcd(n, n+4) = 1$ .
- (c) In general, for  $n, k \in \mathbf{Z}^+$ ,  $\gcd(n, n+k)$  is a divisor of  $k$ . Consequently, if  $k$  is a prime, then  $\gcd(n, n+k) = k$ , for  $n$  a multiple of  $k$ , and  $\gcd(n, n+k) = 1$ , for  $n$  not a multiple of  $k$ .
7. Let  $\gcd(a, b) = h$ ,  $\gcd(b, d) = g$ .  $\gcd(a, b) = h \implies h|a, h|b \implies h|(a \cdot 1 + bc) \implies h|d$ .  $h|b, h|d \implies h|g$ .  $\gcd(b, d) = g \implies g|b, g|d \implies g|(d \cdot 1 + b(-c)) \implies g|a$ .  $g|b, g|a, h = \gcd(a, b) \implies g|h$ .  $h|g, g|h$ , with  $g, h \in \mathbf{Z}^+ \implies g = h$ .
8.  $\gcd(a, b) = 1 \implies ax + by = 1$  for some  $x, y \in \mathbf{Z}$ . Then  $c = acx + bcy$ .  $a|c \implies c = ad$ ,  $b|c \implies c = be$ , so  $c = ab(ex + dy)$  and  $ab|c$ . The result is false if  $\gcd(a, b) \neq 1$ . For example, let  $a = 12, b = 18, c = 36$ . Then  $a|c, b|c$  but  $(ab) \nmid c$ .
9. (a) If  $c \in \mathbf{Z}^+$ , then  $c = \gcd(a, b)$  if (and only if)
- (1)  $c | a$  and  $c | b$ ; and
  - (2)  $\forall d \in \mathbf{Z} [(d | a) \wedge (d | b)] \implies d | c$
- (b) If  $c \in \mathbf{Z}^+$ , then  $c \neq \gcd(a, b)$  if (and only if)
- (1)  $c \nmid a$  or  $c \nmid b$ ; or
  - (2)  $\exists d \in \mathbf{Z} [(d | a) \wedge (d | b) \wedge (d \nmid c)]$ .
10. If  $c = \gcd(a - b, a + b)$  then  $c | [(a - b)x + (a + b)y]$  for all  $x, y \in \mathbf{Z}$ . In particular, for  $x = y = 1$ ,  $c | 2a$ , and for  $x = -1, y = 1$ ,  $c | 2b$ . From Exercise 4,  $\gcd(2a, 2b) = 2 \gcd(a, b) = 2$ , so  $c | 2$  and  $c = 1$  or  $2$ .
11.  $\gcd(a, b) = 1 \implies ax + by = 1$ , for some  $a, b \in \mathbf{Z}$ . Then  $acx + bcy = c$ .  $a|acx, a|bcy$  (since  $a|bc$ )  $\implies a|c$ .
12. Proof: Let  $d_1 = \gcd(a, b)$  and  $d_2 = \gcd(a - b, b)$ .  
 $d_2 = \gcd(a - b, b) \implies [d_2 | (a - b) \wedge d_2 | b] \implies [d_2 | ((a - b) + b)]$  by part (f) of Theorem 4.3  $\implies d_2 | a$ ,  
and  $[d_2 | a \wedge d_2 | b] \implies d_2 | d_1$ .  
 $d_1 = \gcd(a, b) \implies [d_1 | a \wedge d_1 | b] \implies d_1 | [a + (-1)b]$ , by part (f) of Theorem 4.3. Hence  $d_1 | (a - b)$ .

Since  $d_1|(a-b)$  and  $d_1|b$ , it follows that  $d_1|d_2$ . Consequently, we find that  $[d_1|d_2 \wedge d_2|d_1 \wedge \gcd(d_1, d_2) > 0] \Rightarrow \gcd(a, b) = d_1 = d_2 = \gcd(a-b, b)$ .

13. Proof: We find that for each  $n \in \mathbf{Z}^+$ ,  $(5n+3)(7)+(7n+4)(-5) = (35n+21)-(35n+20) = 1$ . Consequently, it follows that the  $\gcd(5n+3, 7n+4) = 1$ , or  $5n+3$  and  $7n+4$  are relatively prime.

14.  $33x + 29y = 2490$

$\gcd(33, 29) = 1$ , and  $33 = (1)(29) + 4$ ,  $29 = (7)(4) + 1$ , so  $1 = 29 - 7(4) = 29 - 7[33 - 29] = 8(29) - 7(33)$ .  $1 = 33(-7) + 29(8) \Rightarrow 2490 = 33(-17430) + 29(19920) = 33(-17430 + 29k) + 29(19920 - 33k)$ , for all  $k \in \mathbf{Z}$ .

$$x = -17430 + 29k, y = 19920 - 33k$$

$$x \geq 0 \Rightarrow 29k \geq 17430 \Rightarrow k \geq 602$$

$$y \geq 0 \Rightarrow 19920 \geq 33k \Rightarrow 603 \geq k$$

$$k = 602 : x = 28, y = 54; k = 603 : x = 57, y = 21.$$

15. We need to find  $x, y \in \mathbf{Z}^+$  where  $y > x$  and  $20x + 50y = 1020$ , or  $2x + 5y = 102$ . As  $\gcd(2, 5) = 1$  we start with  $2(-2) + 5(1) = 1$  and find that  $2(-2) + 5(1) = 1 \Rightarrow 102 = 2(-204) + 5(102) = 2[-204 + 5k] + 5[102 - 2k]$ . Since  $x = -204 + 5k > 0$ , it follows that  $k > 204/5 = 40.8$  and  $y = 102 - 2k > 0$  implies that  $51 > k$ . Consequently  $k = 41, 42, 43, \dots, 50$ . Since  $y > x$  we find the following solutions:

$k$	$x = -204 + 5k$	$y = 102 - 2k$
41	1	20
42	6	18
43	11	16

16. Proof: Suppose that there exist  $c, d \in \mathbf{Z}^+$  with  $cd = a$  and  $\gcd(c, d) = b$ . Since  $\gcd(c, d) = b$ , we have  $c = bc_1$ ,  $d = bd_1$ . Consequently,  $a = cd = (bc_1)(bd_1) = b^2(c_1d_1)$ , so  $b^2|a$ .

Conversely,  $b^2|a \Rightarrow b^2x = a$ , for some  $x \in \mathbf{Z}^+$ . Let  $c = bx$  and  $d = b$ . Then  $cd = a$  and  $\gcd(c, d) = \gcd(bx, b) = b$ .

17.  $\gcd(84, 990) = 6$ , so  $84x + 990y = c$  has a solution  $x_0, y_0$  in  $\mathbf{Z}$  if  $6|c$ . For  $10 < c < 20$ ,  $6|c \Rightarrow c = 12$  or  $18$ . There is no solution for  $c = 11, 13, 14, 15, 16, 17, 19$ .

When  $c = 12$ ,  $84x + 990y = 12$  (or,  $14x + 165y = 2$ ).

$$165 = 11(14) + 11$$

$$14 = 1(11) + 3$$

$$11 = 3(3) + 2$$

$$3 = 1(2) + 1$$

Therefore  $1 = 3 - 2 = 3 - [11 - 3(3)] = 4(3) - 11 = 4[14 - 11] - 11 = 4(14) - 5(11) = 4(14) - 5[165 - 11(14)] = 59(14) - 5(165)$

$$1 = 14(59) + 165(-5)$$

$$2 = 14(118) + 165(-10) = 14(118 - 165k) + 165(-10 + 14k).$$

The solutions for  $84x + 990y = 12$  are  $x = 118 - 165k, y = -10 + 14k, k \in \mathbf{Z}$ .

When  $c = 18$ , the solutions are  $x = 177 - 165k, y = -15 + 14k, k \in \mathbf{Z}$ .

18. Let  $a, b, c \in \mathbf{Z}^+$ . If  $ax + by = c$  has a solution  $x_0, y_0 \in \mathbf{Z}$ , then  $ax_0 + by_0 = c$ , and since  $\gcd(a, b)$  divides  $a$  and  $b$ ,  $\gcd(a, b) | c$ . Conversely, suppose  $\gcd(a, b) | c$ . Then  $c = \gcd(a, b)d$ , for some  $d \in \mathbf{Z}$ . Since  $\gcd(a, b) = as + bt$ , for some  $s, t \in \mathbf{Z}$ , we have  $a(sd) + b(td) = \gcd(a, b)d = c$  or  $ax_0 + by_0 = c$ , and  $ax + by = c$  has a solution in  $\mathbf{Z}$ .

Let  $\gcd(a, b) = g, \text{lcm}(a, b) = h$ .  $\gcd(a, b) = g \implies as + bt = g$ , for some  $s, t \in \mathbf{Z}$ .  $\text{lcm}(a, b) = h \implies h = ma = nb$ , for some  $m, n \in \mathbf{Z}^+$ .  $hg = has + hbt = nbas + mabt = ab(ns + mt) \implies ab | hg$ .  $\gcd(a, b) = g \implies g | a, g | b$ , so  $(a/g)b = (b/g)a$  is a common multiple of  $a$  and  $b$ . Consequently  $h | (a/g)b$ , and  $hx = (a/g)b$ , for some  $x \in \mathbf{Z}$ , or  $ghx = ab$ . Hence  $gh | ab$ .

19. From Theorem 4.10 we know that  $ab = \text{lcm}(a, b) \cdot \gcd(a, b)$ . Consequently,  $b = [\text{lcm}(a, b) \cdot \gcd(a, b)]/a = (242, 500)(105)/630 = 40, 425$ .
20.  $\text{lcm}(a, b) = (ab)/\gcd(a, b)$   
 (a)  $\text{lcm}(231, 1820) = (231)(1820)/7 = 60,060$   
 (b)  $\text{lcm}(1369, 2597) = (1369)(2597) = 3,555,293$   
 (c)  $\text{lcm}(2689, 4001) = (2689)(4001) = 10,758,689$
21.  $\gcd(n, n + 1) = 1, \text{lcm}(n, n + 1) = n(n + 1)$
22. Proof: The result follows from Theorem 14.10 and Exercise 4 for this section. We find that  $\text{lcm}(na, nb) = \frac{(na)(nb)}{\gcd(na, nb)} = \frac{n^2 ab}{n \gcd(a, b)} = n \left[ \frac{ab}{\gcd(a, b)} \right] = n \text{lcm}(a, b)$ .

### Section 4.5

1. (a)  $2^2 \cdot 3^3 \cdot 5^3 \cdot 11$                       (b)  $2^4 \cdot 3 \cdot 5^2 \cdot 7^2 \cdot 11^2$   
 (c)  $3^2 \cdot 5^3 \cdot 7^2 \cdot 11 \cdot 13$
2.  $\gcd(148500, 7114800) = 2^2 \cdot 3 \cdot 5^2 \cdot 11 = 3300$   
 $\text{lcm}(148500, 7114800) = 2^4 \cdot 3^3 \cdot 5^3 \cdot 7^2 \cdot 11^2 = 320166000$   
 $\gcd(148500, 7882875) = 3^2 \cdot 5^3 \cdot 11 = 12375$   
 $\text{lcm}(148500, 7882875) = 2^2 \cdot 3^3 \cdot 5^3 \cdot 7^2 \cdot 11 \cdot 13 = 94594500$   
 $\gcd(7114800, 7882875) = 3 \cdot 5^2 \cdot 7^2 \cdot 11 = 40425$   
 $\text{lcm}(7114800, 7882875) = 2^4 \cdot 3^2 \cdot 5^3 \cdot 7^2 \cdot 11^2 \cdot 13 = 1387386000$
- 3.

$$m^2 = p_1^{2e_1} p_2^{2e_2} p_3^{2e_3} \cdots p_i^{2e_i}$$

$$m^3 = p_1^{3e_1} p_2^{3e_2} p_3^{3e_3} \cdots p_i^{3e_i}$$

4. The result is true for  $n = 1$ . From Lemma 4.2 the result follows for  $n = 2$ . For  $k \geq 2$ , assume that  $p|a_1a_2 \cdots a_k \implies p|a_i$ , for some  $1 \leq i \leq k$ . Now consider  $p|a_1a_2 \cdots a_k a_{k+1}$ . Then  $p|(a_1a_2 \cdots a_k)a_{k+1} \implies p|a_1a_2 \cdots a_k$  or  $p|a_{k+1}$  (by the case where  $n = 2$ )  $\implies p|a_i$  for some  $1 \leq i \leq k$  (by the induction hypothesis) or  $p|a_{k+1} \implies p|a_i$  for some  $1 \leq i \leq k+1$ . The general result then follows by the Principle of Mathematical Induction.
5. Proof: (The proof is similar to that given in Example 4.41.)  
If not, we have  $\sqrt{p} = a/b$ , where  $a, b \in \mathbf{Z}^+$  and  $\gcd(a, b) = 1$ . Then  $\sqrt{p} = a/b \implies p = a^2/b^2 \implies pb^2 = a^2 \implies p | a^2 \implies p | a$  (by Lemma 4.2). Since  $p | a$  we know that  $a = pk \exists k \in \mathbf{Z}^+$ , and  $pb^2 = a^2 = (pk)^2 = p^2k^2$ , or  $b^2 = pk^2$ . Hence  $p | b^2$  and so  $p | b$ . But if  $p | a$  and  $p | b$  then  $\gcd(a, b) = p > 1$  — contradicting our earlier claim that  $\gcd(a, b) = 1$ .
6. Here  $25n + 10n + 40n = 100k$ , so  $75n = 100k$ , or  $3n = 4k$ . From Lemma 4.2 it follows that  $3|k$ . So  $k = 3 \cdot r$ . Then  $3n = 4(3 \cdot r) \implies n = 4r$ . So  $n$  is any positive multiple of 4.
7. (a)  $3 \times 4 \times 4 \times 2 = 96$                       (b) 270                      (c) 144
8. a) There are  $(15)(10)(9)(11)(4)(6)(11) = 3,920,400$  positive divisors of  $n = 2^{14}3^95^87^{10}11^313^537^{10}$ .  
b) (i)  $(14 - 3 + 1)(9 - 4 + 1)(8 - 7 + 1)(10 - 0 + 1)(3 - 2 + 1)(5 - 0 + 1)(10 - 2 + 1) = (12)(6)(2)(11)(2)(6)(9) = 171,072$   
(ii) Since  $1,166,400,000 = 2^93^65^5$ , the number of divisors here is  $(14 - 9 + 1)(9 - 6 + 1)(8 - 5 + 1)(10 - 0 + 1)(3 - 0 + 1)(5 - 0 + 1)(10 - 0 + 1) = (6)(4)(4)(11)(4)(6)(11) = 278,784$ .  
(iii)  $(8)(5)(5)(6)(2)(3)(6) = 43,200$   
(iv)  $(7)(3)(4)(6)(1)(3)(6) = 9072$   
(v)  $(5)(4)(3)(4)(2)(2)(4) = 3840$   
(vi)  $(1)(1)(2)(2)(1)(1)(3) = 12$   
(vii)  $(3)(2)(2)(2)(1)(1)(2) = 48$
9. From Theorem 4.10 we know that  $mn = \text{lcm}(m, n) \cdot \gcd(m, n)$ , so  $\gcd(m, n) = mn/\text{lcm}(m, n) = 2^23^15^111^1 = 660$ .
10.  $\gcd = 3 \cdot 5^2 \cdot 11 = 285$   
 $\text{lcm} = 2^4 \cdot 3^3 \cdot 5^3 \cdot 7^2 \cdot 11^2 \cdot 13 = 4,162,158,000$
11.  $248396544 = 2^8 \cdot 3^6 \cdot 11^3$ , so there are  $(8 + 1)(6 + 1)(3 + 1) = 252$  possibilities for  $n$ .
12. Since  $2a$  is a perfect square we have  $a = 2x^2$ , for some  $x \in \mathbf{Z}^+$ . Likewise,  $3a$  a perfect cube  $\implies a = 3^2y^3 = (3y)^2y$  for some  $y \in \mathbf{Z}^+$ . To minimize the value of  $a$  choose  $y = 2$  and  $x = 3y = 6$ . Then  $a = 72 = 2^3 \cdot 3^2$ .
13. a) Proof: (i) Since  $10|a^2$  we have  $5|a^2$  and  $2|a^2$ . Then by Lemma 4.2 it follows that  $5|a$  and  $2|a$ . So  $a = 5b$  for some  $b \in \mathbf{Z}^+$ . Further, since  $2|5b$  we have  $2|5$  or  $2|b$  (by Lemma 4.2). Consequently,  $a = 5b = 5(2c) = 10c$ , and 10 divides  $a$ .  
(ii) This result is false — let  $a = 2$ .
- b) We can generalize section (i) of part (a) by replacing 10 by an integer  $n$  of the form

$p_1 p_2 \cdots p_t$ , a product of  $t$  distinct primes. (So  $n$  is a square-free integer — that is, no square greater than 1 divides  $n$ .)

14. Proof: We find that  $abcabc = (abc)(1001) = (abc)(7)(11)(13)$ .
15. Since  $7! = 2^4 \cdot 3^2 \cdot 5 \cdot 7$ , the smallest perfect square that is divisible by  $7!$  is  $2^4 \cdot 3^2 \cdot 5^2 \cdot 7^2 = (35) \times (7!) = 176,400$ .
16. If  $n \in \mathbf{Z}^+$  and  $n$  is a perfect square, then  $n = p_1^{e_1} p_2^{e_2} \cdots p_k^{e_k}$ , where  $p_i$  is prime and  $e_i$  is a positive even integer for all  $1 \leq i \leq k$ . Hence  $(e_1 + 1)(e_2 + 1) \cdots (e_k + 1)$  is a product of odd integers. Therefore the number of positive divisors of  $n$  is odd.  
Conversely, if  $n \in \mathbf{Z}^+$  and  $n$  is not a perfect square, then  $n = p_1^{e_1} p_2^{e_2} \cdots p_k^{e_k}$  where each  $p_i$  is prime and  $e_i$  is odd for some  $1 \leq i \leq k$ . Therefore  $(e_i + 1)$  is even for some  $1 \leq i \leq k$ , so  $(e_1 + 1)(e_2 + 1) \cdots (e_k + 1)$  is even and  $n$  has an even number of positive divisors.
17. For  $1260 \times n$  to be a perfect cube, the exponent on each prime divisor must be a multiple of 3. Since  $1260 = 2^2 \cdot 3^2 \cdot 5 \cdot 7$ , we want  $1260 \times n = 2^3 \cdot 3^3 \cdot 5^3 \cdot 7^3$ , so  $n = 2 \cdot 3 \cdot 5^2 \cdot 7^2 = 7350$ .
18. (a) Since  $200 = 2^3 \cdot 5^2$ , the number of times the 200th coin will be turned over is  $(4)(3) = 12$ , the number of divisors of 200.  
(b) The following coins will also be turned over 12 times:  
(i)  $2^3 \cdot 3^2 = 72$       (ii)  $2^5 \cdot 3 = 96$       (iii)  $2^2 \cdot 3^3 = 108$       (iv)  $2^5 \cdot 5 = 160$   
(c) The 192nd coin is turned over 14 times because  $192 = 2^6 \cdot 3$ .
19. (a)  $4 = 2^2$ ;  $8 = 2^3$ ;  $16 = 2^4$ ;  $32 = 2^5$ .  
Considering the powers of 2, there are 5 different sums of two distinct exponents:  $5 = 2 + 3$ ;  $6 = 2 + 4$ ;  $7 = 2 + 5 = 3 + 4$ ;  $8 = 3 + 5$ ;  $9 = 4 + 5$ . Hence there are 5 different products that we can form.  
(b) Here we have  $2^n$  for  $n = 2, 3, 4, 5$  and 6. Now there are 7 different sums of two distinct exponents:  $5 = 2 + 3$ ;  $6 = 2 + 4$ ;  $7 = 2 + 5 = 3 + 4$ ;  $8 = 2 + 6 = 3 + 5$ ;  $9 = 3 + 6 = 4 + 5$ ;  $10 = 4 + 6$ ;  $11 = 5 + 6$ . Consequently, we can form 7 different products in this case.  
(c) The set here may also be represented as  $A \cup B$  where  $A = \{2^n | n \in \mathbf{Z}^+, 2 \leq n \leq 6\}$  and  $B = \{3^k | k \in \mathbf{Z}^+, 2 \leq k \leq 5\}$ .  
If the product uses two integers from  $A$  then there are 7 possibilities. If both integers are selected from  $B$  then we have 5 possibilities. Finally there are  $5 \times 4 = 20$  products using one number from each of the sets  $A, B$ . In total, the number of different products is  $7 + 5 + 20 = 32$ .  
(d) Consider the set given here as  $A \cup B \cup C$  where  $A = \{4, 8, 16, 32, 64\}$ ,  $B = \{9, 27, 81, 243, 729\}$  and  $C = \{25, 125, 625, 3125\}$ .

Here there are six cases to enumerate.

- (1) Both elements from  $A$ : 7 possibilities.
- (2) Both elements from  $B$ : 7 possibilities.
- (3) Both elements from  $C$ : 5 possibilities.
- (4) One element from each of  $A, B$ :  $5 \times 5 = 25$  possibilities.

- (5) One element from each of  $A, C$ :  $5 \times 4 = 20$  possibilities.  
 (6) One element from each of  $B, C$ :  $5 \times 4 = 20$  possibilities.  
 In total there are  $7 + 7 + 5 + 25 + 20 + 20 = 84$  possible products.  
 (e) This case generalizes the result in part (d). Once again there are 84 possible products.

20. Program Primefactors (input,output);

```

Var
  p, j, k, n, originalvalue, count: integer;
Begin
  Write ('The value of n is ');
  Read (n);
  originalvalue := n;
  Writeln ('The prime factorization of ', n:0, ' is ');
  If n Mod 2 = 0 Then
    Begin
      count := 0;
      While n Mod 2 = 0 Do
        Begin
          count := count + 1;
          n := n Div 2
        End;
      Write ('2(', count:0, ') ');
    End;
  If n Mod 3 = 0 Then
    Begin
      count := 0;
      While n Mod 3 = 0 Do
        Begin
          count := count + 1;
          n := n Div 3
        End;
      Write ('3(', count :0, ') ');
    End;
  p := 5;
  While n >= 5 Do
    Begin
      j := 1;
      Repeat
        j := j + 1;
        k := p Mod j
      Until (k = 0) Or (j = Trunc(Sqrt(p)));
      If (k <> 0) And (n Mod p = 0) Then

```

```

Begin
  count := 0;
  While n Mod p = 0 Do
    Begin
      count := count + 1;
      n := n Div p
    End;
  Write (p:0, ' ', count:0, ' ');
End;
p := p + 2
End;
End.

```

21. The length of  $AB = 2^8 = 256$ ; the length of  $AC = 2^9 = 512$ . The perimeter of the triangle is 1061.

22. (a)  $\prod_{i=1}^{10} (-1)^i = -1$

(b)  $\prod_{i=1}^{2n+1} (-1)^i = (-1)^{(2n+1)(2n+2)/2} = (-1)^{(2n+1)(n+1)} = \begin{cases} 1, & \text{for } n \text{ odd} \\ -1, & \text{for } n \text{ even} \end{cases}$

(c)  $\prod_{i=4}^8 \frac{(i+1)(i+2)}{(i-1)(i)} = \left(\frac{5 \cdot 6}{3 \cdot 4}\right) \left(\frac{6 \cdot 7}{4 \cdot 5}\right) \left(\frac{7 \cdot 8}{5 \cdot 6}\right) \left(\frac{8 \cdot 9}{6 \cdot 7}\right) \left(\frac{9 \cdot 10}{7 \cdot 8}\right) = \frac{8 \cdot 9 \cdot 9 \cdot 10}{3 \cdot 4 \cdot 4 \cdot 5} = 27$

(d)  $\prod_{i=n}^{2n} \frac{i}{2n-i+1} = \binom{n}{n+1} \binom{n+1}{n} \binom{n+2}{n-1} \cdots \binom{2n-1}{2} \binom{2n}{1} = \frac{(2n)!}{(n-1)!} / (n+1)! = (2n)! / [(n-1)!(n+1)!] = \binom{2n}{n-1} = \binom{2n}{n+1}$

23. (a) From the Fundamental Theorem of Arithmetic  $88,200 = 2^3 \cdot 3^2 \cdot 5^2 \cdot 7^2$ . Consider the set  $F = \{2^3, 3^2, 5^2, 7^2\}$ . Each subset of  $F$  determines a factorization  $ab$  where  $\gcd(a, b) = 1$ . There are  $2^4$  subsets – hence,  $2^4$  factorizations. Since order is not relevant, this number (of factorizations) reduces to  $(1/2)2^4 = 2^3$ . And since  $1 < a < n$ ,  $1 < b < n$ , we remove the case for the empty subset of  $F$  (or the subset  $F$  itself). This yields  $2^3 - 1$  such factorizations.

(b) Here  $n = 2^3 \cdot 3^2 \cdot 5^2 \cdot 7^2 \cdot 11$  and there are  $2^4 - 1$  such factorizations.

(c) Suppose that  $n = p_1^{n_1} p_2^{n_2} \cdots p_k^{n_k}$ , where  $p_1, p_2, \dots, p_k$  are  $k$  distinct primes and  $n_1, n_2, \dots, n_k \geq 1$ . The number of unordered factorizations of  $n$  as  $ab$ , where  $1 < a < n$ ,  $1 < b < n$ , and  $\gcd(a, b) = 1$ , is  $2^{k-1} - 1$ .

24. (a)  $\prod_{i=1}^5 (i^2 + i)$       (b)  $\prod_{i=1}^5 (1 + x^i)$       (c)  $\prod_{i=1}^6 (1 + x^{2i-1})$

25. Proof: (By Mathematical Induction)

For  $n = 2$  we find that  $\prod_{i=2}^2 (1 - \frac{1}{i^2}) = (1 - \frac{1}{2^2}) = (1 - \frac{1}{4}) = 3/4 = (2 + 1)/(2 \cdot 2)$ , so the result is true in this first case and this establishes the basis step for our inductive proof.

Next we assume the result true for some (particular)  $k \in \mathbf{Z}^+$  where  $k \geq 2$ . This gives us

$\prod_{i=2}^k (1 - \frac{1}{i^2}) = (k + 1)/(2k)$ . When we consider the case for  $n = k + 1$ , using the inductive step, we find that

$$\prod_{i=2}^{k+1} (1 - \frac{1}{i^2}) = \left( \prod_{i=2}^k (1 - \frac{1}{i^2}) \right) \left( 1 - \frac{1}{(k+1)^2} \right) = [(k+1)/(2k)] \left[ 1 - \frac{1}{(k+1)^2} \right] =$$

$$\left[ \frac{k+1}{2k} \right] \left[ \frac{(k+1)^2 - 1}{(k+1)^2} \right] = \frac{k^2 + 2k}{(2k)(k+1)} = (k+2)/(2(k+1)) = ((k+1) + 1)/(2(k+1)).$$

The result now follows for all positive integers  $n \geq 2$  by the Principle of Mathematical Induction.

26. (a) When  $n$  is a prime then it has exactly two positive divisors — namely, 1 and  $n$ .  
 (b) If  $n = p^2$ , where  $p$  is a prime, then  $n$  has exactly three positive divisors — namely, 1,  $p$ , and  $p^2$ .  
 (c) Let  $p, q$  denote two distinct primes. If  $n = p^3$  or  $n = pq$ , then  $n$  has exactly four positive divisors — 1,  $p, p^2$ , and  $p^3$  for  $n = p^3$ , and 1,  $p, q$  and  $pq$  for  $n = pq$ .  
 (d) If  $n = p^4$ , where  $p$  is a prime, then  $n$  has exactly five positive divisors — namely, 1,  $p, p^2, p^3$ , and  $p^4$ .

27. (a) The positive divisors of 28 are 1, 2, 4, 7, 14, and 28, and  $1 + 2 + 4 + 7 + 14 + 28 = 56 = 2(28)$ , so 28 is a perfect integer.

The positive divisors of 496 are 1, 2, 4, 8, 16, 31, 62, 124, 248, and 496, and  $1 + 2 + 4 + 8 + 16 + 31 + 62 + 124 + 248 + 496 = 992 = 2(496)$ , so 496 is a perfect integer.

(b) It follows from the Fundamental Theorem of Arithmetic that the divisors of  $2^{m-1}(2^m - 1)$ , for  $2^m - 1$  prime, are 1, 2,  $2^2, 2^3, \dots, 2^{m-1}$ , and  $(2^m - 1), 2(2^m - 1), 2^2(2^m - 1), 2^3(2^m - 1), \dots$ , and  $2^{m-1}(2^m - 1)$ .

These divisors sum to  $[1 + 2 + 2^2 + 2^3 + \dots + 2^{m-1}] + (2^m - 1)[1 + 2 + 2^2 + 2^3 + \dots + 2^{m-1}] = (2^m - 1) + (2^m - 1)(2^m - 1) = (2^m - 1)[1 + (2^m - 1)] = 2^m(2^m - 1) = 2[2^{m-1}(2^m - 1)]$ , so  $2^{m-1}(2^m - 1)$  is a perfect integer.

### Supplementary Exercises

1.  $a + (a + d) + (a + 2d) + \dots + (a + (n - 1)d) = na + [(n - 1)nd]/2$ . For  $n = 1, a = a + 0$ , and the result is true in this case. Assuming that  $\sum_{i=1}^k [a + (i - 1)d] = ka + [(k - 1)kd]/2$ , we have  $\sum_{i=1}^{k+1} [a + (i - 1)d] = (ka + [(k - 1)kd]/2) + (a + kd) = (k + 1)a + [k(k + 1)d]/2$ , so the result follows for all  $n \in \mathbf{Z}^+$  by the Principle of Mathematical Induction.

2. Let  $t$  be the number of times the while loop is executed. Then we have  
 $\text{sum} = 10 + 17 + 24 + \dots + (10 + 7(t - 1)) = 10 + (10 + 7) + (10 + 14) + \dots + (10 + 7(t - 1))$ .

From the previous exercise we know that for each  $t \in \mathbf{Z}^+$

$a + (a + d) + (a + 2d) + \dots + (a + (t - 1)d) = ta + [(t - 1)(t)d]/2$ , so here we have

$$\text{sum} = 10t + (7/2)t(t - 1).$$

For  $t = 52$ , we have  $\text{sum} = 9802$ , and for  $t = 53$ , we find  $\text{sum} = 10176$ . Therefore,  $n$ , the last summand, is  $10 + 7(52 - 1) = 367$ .

3. Conjecture:  $\sum_{i=1}^n (-1)^{i+1} i^2 = (-1)^{n+1} \sum_{i=1}^n i$ , for all  $n \in \mathbf{Z}^+$ .

Proof: (By the Principle of Mathematical Induction)

If  $n = 1$  the conjecture provides  $\sum_{i=1}^1 (-1)^{i+1} i^2 = (-1)^{1+1} (1)^2 = 1 = (-1)^{1+1} (1) = (-1)^{1+1} \sum_{i=1}^1 i$ ,

which is a true statement. This establishes the basis step of the proof.

In order to confirm the inductive step, we shall assume the truth of the result

$$\sum_{i=1}^k (-1)^{i+1} i^2 = (-1)^{k+1} \sum_{i=1}^k i$$

for some (particular)  $k \geq 1$ . When  $n = k + 1$  we find that

$$\begin{aligned} \sum_{i=1}^{k+1} (-1)^{i+1} i^2 &= \left( \sum_{i=1}^k (-1)^{i+1} i^2 \right) + (-1)^{(k+1)+1} (k+1)^2 \\ &= (-1)^{k+1} \sum_{i=1}^k i + (-1)^{k+2} (k+1)^2 = (-1)^{k+1} (k)(k+1)/2 + (-1)^{k+2} (k+1)^2 \\ &= (-1)^{k+2} [(k+1)^2 - (k)(k+1)/2] \\ &= (-1)^{k+2} (1/2) [2(k+1)^2 - k(k+1)] \\ &= (-1)^{k+2} (1/2) [2k^2 + 4k + 2 - k^2 - k] \\ &= (-1)^{k+2} (1/2) [k^2 + 3k + 2] = (-1)^{k+2} (1/2) (k+1)(k+2) \\ &= (-1)^{k+2} \sum_{i=1}^{k+1} i, \end{aligned}$$

so the truth of the result at  $n = k$  implies the truth at  $n = k + 1$  — and we have the inductive step.

It then follows by the Principle of Mathematical Induction that

$$\sum_{i=1}^n (-1)^{i+1} i^2 = (-1)^{n+1} \sum_{i=1}^n i,$$

for all  $n \in \mathbf{Z}^+$ .

4. (a)  $S(n) : 5|(n^5 - n)$ . For  $n = 1, n^5 - n = 0$  and  $5|0$ , so  $S(1)$  is true. Assume  $S(k) : 5|(k^5 - k)$ . For  $n = k + 1, (k + 1)^5 - (k + 1) = (k^5 - k) + 5k^4 + 10k^3 + 10k^2 + 5k$ . Based on  $S(k), 5|((k + 1)^5 - (k + 1))$  so  $S(k) \implies S(k + 1)$  and the result is true for all  $n \in \mathbf{Z}^+$  by the Principle of Mathematical Induction.

(b)  $S(n) : 6|(n^3 + 5n)$ . When  $n = 1, n^3 + 5n = 6$ , so  $S(1)$  is true. Assuming  $S(k)$ , consider  $S(k + 1)$ .  $(k + 1)^3 + 5(k + 1) = (k^3 + 5k) + 6 + 3(k)(k + 1)$ . Since one of  $k, k + 1$  must be

even,  $6|[3(k)(k+1)]$ . Then assuming  $S(k)$  we have  $6|[(k+1)^3 + 5(k+1)]$  and the general result is true for all  $n \in \mathbf{Z}^+$  by the Principle of Mathematical Induction.

5.

(a)	$n$	$n^2 + n + 41$	$n$	$n^2 + n + 41$	$n$	$n^2 + n + 41$
	1	43	4	61	7	97
	2	47	5	71	8	113
	3	53	6	83	9	131

(b) For  $n = 39$ ,  $n^2 + n + 41 = 1601$ , a prime. But for  $n = 40$ ,  $n^2 + n + 41 = (41)^2$ , so  $S(39) \not\Rightarrow S(40)$ .

6. (b)  $s_4 = 119/120 = (5! - 1)/5!$       $s_5 = 719/720 = (6! - 1)/6!$   
 $s_6 = 5039/5040 = (7! - 1)/7!$

(c)  $s_n = [(n+1)! - 1]/(n+1)!$

(d) Based on the calculation in part (a) the conjecture is true for  $n = 1$ . Assuming that  $s_k = [(k+1)! - 1]/(k+1)!$ , for  $k \in \mathbf{Z}^+$ , consider  $s_{k+1}$ .

$s_{k+1} = s_k + (k+1)/(k+2)! = [(k+1)! - 1]/(k+1)! + (k+1)/(k+2)! = [(k+2)! - (k+2) + (k+1)]/(k+2)! = [(k+2)! - 1]/(k+2)!$ , so the result follows for all  $n \in \mathbf{Z}^+$  by the Principle of Mathematical Induction.

7. (a) For  $n = 0$ ,  $2^{2n+1} + 1 = 2 + 1 = 3$ , so the result is true in this first case. Assuming that 3 divides  $2^{2k+1} + 1$  for  $n = k \in \mathbf{N}$ , consider the case of  $n = k + 1$ . Since  $2^{2(k+1)+1} + 1 = 2^{2k+3} + 1 = 4(2^{2k+1}) + 1 = 4(2^{2k+1} + 1) - 3$ , and 3 divides both  $2^{2k+1} + 1$  and 3, it follows that 3 divides  $2^{2(k+1)+1} + 1$ . Consequently, the result is true for  $n = k + 1$  whenever it is true for  $n = k$ . So by the Principle of Mathematical Induction the result follows for all  $n \in \mathbf{N}$ .

(b) When  $n = 0$ ,  $0^3 + (0+1)^3 + (0+2)^3 = 9$ , so the statement is true in this case. We assume the truth of the result when  $n = k \geq 0$  and examine the result for  $n = k + 1$ . We find that  $(k+1)^3 + (k+2)^3 + (k+3)^3 = (k+1)^3 + (k+2)^3 + [k^3 + 9k^2 + 27k + 27] = [k^3 + (k+1)^3 + (k+2)^3] + [9(k^2 + 3k + 3)]$ , where the first summand is divisible by 9 because of the induction hypothesis. Consequently, since the result is true for  $n = 0$ , and since the truth at  $n = k (\geq 0)$  implies the truth for  $n = k + 1$ , it follows from the Principle of Mathematical Induction that the statement is true for all integers  $n \geq 0$ .

8. Proof: There are four cases to consider.

(1)  $n = 10m + 1$ . Here  $n^1$  satisfies the condition sought.

(2)  $n = 10m + 3$ . Here  $n^2 = 100m^2 + 60m + 9$  and  $n^4 = 10000m^4 + 12000m^3 + 5400m^2 + 1080m + 81 = 10(1000m^4 + 1200m^3 + 540m^2 + 108m + 8) + 1$ , so the units digit of  $n^4$  is 1.

(3)  $n = 10m + 7$ . As in case (2) we need  $n^4$ . For  $n^2 = 100m^2 + 140m + 49$ , and  $n^4 = 10000m^4 + 28000m^3 + 29400m^2 + 13720m + 2401 = 10(1000m^4 + 2800m^3 + 2940m^2 + 1372m + 240) + 1$ , where the units digit is 1.

(4)  $n = 10m + 9$ . Fortunately we only need  $n^2$  here, since  $n^2 = 100m^2 + 180m + 81 = 10(10m^2 + 18m + 8) + 1$ .

[Note: For any  $n \in \mathbf{Z}^+$ , where  $n$  is odd and *not* divisible by 5, we always find the units digit in  $n^4$  to be 1.]

9. Converting to base 10 we find that  $81x + 9y + z = 36z + 6y + x$ , and so  $80x + 3y - 35z = 0$ . Since  $5|(80x - 35z)$  and  $\gcd(3, 5) = 1$ , it follows that  $5|y$ . Consequently,  $y = 0$  or  $y = 5$ . For  $y = 0$  the equation  $80x - 35z = 0$  leads us to  $16x - 7z = 0$  and  $16x = 7z \Rightarrow 16|z$ . Since  $0 \leq z \leq 5$  we find here that  $z = 0$  and the solution is  $x = y = z = 0$ . If  $y = 5$ , then  $80x + 15 - 35z = 0 \Rightarrow 16x + 3 - 7z = 0$ . With  $0 \leq x, z \leq 5$ ,  $16x = 7z - 3 \Rightarrow z$  is odd and  $z = 1, 3$ , or  $5$ . Since 16 does *not* divide  $4(= 7(1) - 3)$  or  $18(= 7(3) - 3)$ , and since 16 *does* divide  $32(= 7(5) - 3)$  we find that  $z = 5$  and  $x = 2$ . Hence  $x = 2$ ,  $y = 5$ , and  $z = 5$ . [And we see that  $(xyz)_9 = 81x + 9y + z = 81(2) + 9(5) + 5 = 212 = 36(5) + 6(5) + 2 = 36z + 6y + x = (zyx)_6$ .]
10. From the Fundamental Theorem of Arithmetic we have  $3000 = 2^3 \cdot 3^1 \cdot 5^3$ , so 3000 has  $(3 + 1)(1 + 1)(3 + 1) = 32$  divisors. Since  $\gcd(n, n + 3000)$  is a divisor of 3000, there are 32 possibilities - depending on the value of  $n$ .
11. For  $n = 2$  we find that  $2^2 = 4 < 6 = \binom{4}{2} < 16 = 4^2$ , so the statement is true in this first case. Assuming the result true for  $n = k \geq 2$  - i.e.,  $2^k < \binom{2k}{k} < 4^k$ , we now consider what happens for  $n = k + 1$ . Here we find that 
$$\binom{2(k+1)}{k+1} = \binom{2k+2}{k+1} = \left[ \frac{(2k+2)(2k+1)}{(k+1)(k+1)} \right] \binom{2k}{k} = 2[(2k+1)/(k+1)] \binom{2k}{k} > 2[(2k+1)/(k+1)] 2^k > 2^{k+1}$$
, since  $(2k+1)/(k+1) = [(k+1)+k]/(k+1) > 1$ . In addition,  $[(k+1)+k]/(k+1) < 2$ , so 
$$\binom{2(k+1)}{k+1} = 2[(2k+1)/(k+1)] \binom{2k}{k} < (2)(2) \binom{2k}{k} < 4^{k+1}$$
. Consequently the result is true for all  $n \geq 2$  by the Principle of Mathematical Induction.
12. For  $n = 1$ ,  $7^3 + 8^3 = 855 = (57)(15)$ . Assuming that  $57|(7^{k+2} + 8^{2k+1})$ , since  $7^{(k+1)+2} + 8^{2(k+1)+1} = 7^{k+3} + 8^{2k+3} = 7(7^{k+2}) + 64(8^{2k+1}) = 64(7^{k+2}) + 64(8^{2k+1}) - 57(7^{k+2})$ , we have  $57|(7^{k+3} + 8^{2k+3})$ , so the result follows by the Principle of Mathematical Induction.
13. First we observe that the statement is true for all  $n \in \mathbb{Z}^+$  where  $64 \leq n \leq 68$ . This follows from the calculations:  
 $64 = 2(17) + 6(5)$      $65 = 13(5)$      $66 = 3(17) + 3(5)$      $67 = 1(17) + 10(5)$      $68 = 4(17)$   
 Now assume the result is true for all  $n$  where  $68 \leq n \leq k$  and consider the integer  $k + 1$ . Then  $k + 1 = (k - 4) + 5$ , and since  $64 \leq k - 4 < k$  we can write  $k - 4 = a(17) + b(5)$  for some  $a, b \in \mathbb{N}$ . Consequently,  $k + 1 = a(17) + (b + 1)(5)$ , and the result follows for all  $n \geq 64$  by the Alternative Form of the Principle of Mathematical Induction.
14. To find all such  $a, b$  we solve the Diophantine equation  $12a + 7b = 1$ . Since  $\gcd(12, 7) = 1$ , we start with the Euclidean algorithm:

$$\begin{aligned} 12 &= 1 \cdot 7 + 5, & 0 < 5 < 7 \\ 7 &= 1 \cdot 5 + 2, & 0 < 2 < 5 \\ 5 &= 2 \cdot 2 + 1, & 0 < 1 < 2 \\ 2 &= 2 \cdot 1 \end{aligned}$$

Then  $1 = 5 - 2 \cdot 2 = 5 - 2[7 - 5] = (-2)7 + 3(5) = (-2)7 + 3(12 - 7) = 12 \cdot 3 + 7(-5) = 12[3 + 7k] + 7[-5 - 12k], k \in \mathbb{Z}$ . Hence

$$a = 3 + 7k, \quad b = -5 - 12k, \quad k \in \mathbb{Z}.$$

15. (a)  $r = r_0 + r_1 \cdot 10 + r_2 \cdot 10^2 + \dots + r_n \cdot 10^n = r_0 + r_1(9) + r_1 + r_2(99) + r_2 + \dots + r_n \underbrace{(99 \dots 9)}_n + r_n =$

$[9r_1 + 99r_2 + \dots + (99 \dots 9)r_n] + (r_0 + r_1 + r_2 + \dots + r_n)$ . Hence  $9|r$  iff  $9|(r_0 + r_1 + r_2 + \dots + r_n)$ .  
(c)  $3|t$  for  $x = 1$  or  $4$  or  $7$ ;  $9|t$  for  $x = 7$ .

16.  $50x + 20y = 620 \implies 5x + 2y = 62$

$\gcd(5, 2) = 1$  and  $1 = 5(1) + 2(-2)$  so  $62 = 5(62) + 2(-124) = 5(62 - 2k) + 2(-124 + 5k)$ ,  $k \in \mathbb{Z}$ .  $x = 62 - 2k \geq 0 \implies 31 \geq k$ ;  $y = -124 + 5k \geq 0 \implies k \geq 24.8$

Solutions: (1)  $k = 25 : x = 12, y = 1$ ; (2)  $k = 26 : x = 10, y = 6$ ; (3)  $k = 27 : x = 8, y = 11$ ; (4)  $k = 28 : x = 6, y = 16$ ; (5)  $k = 29 : x = 4, y = 21$ ; (6)  $k = 30 : x = 2, y = 26$ ; (7)  $k = 31 : x = 0, y = 31$ .

17. (a) Let  $n = 2^{e_1} \cdot 3^{e_2} \cdot 5^{e_3} \cdot 7^{e_4} \cdot 11^{e_5}$  where  $e_1 + e_2 + e_3 + e_4 + e_5 = 9$ , with  $e_i \geq 0$  for all  $1 \leq i \leq 5$ . The number of solutions to this equation is  $\binom{5+9-1}{9} = \binom{13}{9}$

(b)  $\binom{8}{4}$

18. (a)  $2^{4(1+2+3)} 5^{4(1+2+3)}$  (b)  $2^{5(1+2+3)} 5^{4(1+2+3+4)}$   
(c)  $2^{2(4)(1+2+3)} 5^{2(4)(1+2+3)} 7^{4(4)(1)}$  (d)  $2^{3(4)(1+2+3)} 3^{4(4)(1+2)} 5^{3(4)(1+2+3)}$

(e)  $p^e q^f$ , where  $e = (n+1)(1+2+\dots+m) = (n+1)(m)(m+1)/2$  and  $f = (m+1)(1+2+\dots+n) = (m+1)(n)(n+1)/2$

(f)  $p^e q^f r^g$ , when  $e = (n+1)(k+1)(1+2+\dots+m) = (n+1)(k+1)(m)(m+1)/2$ ,  $f = (m+1)(k+1)(1+2+\dots+n) = (m+1)(k+1)(n)(n+1)/2$ , and  $g = (m+1)(n+1)(1+2+\dots+k) = (m+1)(n+1)(k)(k+1)/2$ .

19. (a) 1, 4, 9.

(b) 1, 4, 9, 16, ...,  $k$  where  $k$  is the largest square less than or equal to  $n$ .

20. Proof: For  $1 \leq i \leq 5$ , it follows from the division algorithm that  $a_i = 5q_i + r_i$ , where  $0 \leq r_i \leq 4$ . So now we shall consider the remainders:  $r_1, r_2, r_3, r_4, r_5$ . For if a selection of the remainders adds to a multiple of 5, then the sum of the corresponding elements of  $A$  will also sum to a multiple of 5. (Note that for the remainders we need not have five distinct integers.)

1) If  $r_i = 0$  for some  $1 \leq i \leq 5$ , then  $5|a_i$  and we are finished. Therefore we shall assume from this point on that  $r_i \neq 0$  for all  $1 \leq i \leq 5$ .

2) If  $1 \leq r_1 = r_2 = r_3 = r_4 = r_5 \leq 4$ , then  $a_1 + a_2 + \dots + a_5 = 5(q_1 + q_2 + \dots + q_5) + 5r_1$ , and the result follows. Consequently we now narrow our attention to the cases where at least two different nonzero remainders occur.

Case 1: (There are at least three 4's). Here the possibilities to consider are (i)  $4 + 1$ ; (ii)  $4 + 4 + 2$ ; and (iii)  $4 + 4 + 4 + 3$  — these all lead to the result we are seeking.

**Case 2:** (We have one or two 4's). If there is at least one 1, or at least one 2 and one 3, then we are done. Otherwise we get one of the following possibilities: (i)  $4 + 2 + 2 + 2$  or (ii)  $4 + 3 + 3$ .

**Case 3:** (Now there are no 4's and at least one 3.) Then we either have (i)  $3 + 2$ ; (ii)  $3 + 1 + 1$ ; or (iii)  $3 + 3 + 3 + 1$ .

**Case 4:** (We now have only 1's and 2's as summands). The final possibilities are (i)  $2 + 1 + 1 + 1$ ; and (ii)  $2 + 2 + 1$ .

21. (a) For all  $n \in \mathbb{Z}^+$ ,  $n \geq 3$ ,  $1 + 2 + 3 + \dots + n = n(n+1)/2$ . If  $\{1, 2, 3, \dots, n\} = A \cup B$  with  $s_A = s_B$ , then  $2s_A = n(n+1)/2$ , or  $4s_A = n(n+1)$ . Since  $4|n(n+1)$  and  $\gcd(n, n+1) = 1$  then either  $4|n$  or  $4|(n+1)$ .

(b) Here we are verifying the converse of our result in part (a).

(i) If  $4|n$  we write  $n = 4k$ . Here we have  $\{1, 2, 3, \dots, k, k+1, \dots, 3k, 3k+1, \dots, 4k\} = A \cup B$  where  $A = \{1, 2, 3, \dots, k, 3k+1, 3k+2, \dots, 4k-1, 4k\}$  and  $B = \{k+1, k+2, \dots, 2k, 2k+1, 3k-1, 3k\}$ , with  $s_A = (1 + 2 + 3 + \dots + k) + [(3k+1) + (3k+2) + \dots + (3k+k)] = [k(k+1)/2] + k(3k) + [k(k+1)/2] = k(k+1) + 3k^2 = 4k^2 + k$ , and  $s_B = [(k+1) + (k+2) + \dots + (k+k)] + [(2k+1) + (2k+2) + \dots + (2k+k)] = k(k) + [k(k+1)/2] + k(2k) + [k(k+1)/2] = 3k^2 + k(k+1) = 4k^2 + k$ .

(ii) Now we consider the case where  $n+1 = 4k$ . Then  $n = 4k-1$  and we have  $\{1, 2, 3, \dots, k-1, k, \dots, 3k-1, 3k, \dots, 4k-2, 4k-1\} = A \cup B$ , with  $A = \{1, 2, 3, \dots, k-1, 3k, 3k+1, \dots, 4k-1\}$  and  $B = \{k, k+1, \dots, 2k-1, 2k, 2k+1, \dots, 3k-1\}$ . Here we find  $s_A = [1 + 2 + 3 + \dots + (k-1)] + [3k + (3k+1) + \dots + (3k + (k-1))] = [(k-1)(k)/2] + k(3k) + [(k-1)(k)/2] = 3k^2 + k^2 - k = 4k^2 - k$ , and  $s_B = [k + (k+1) + \dots + (k + (k-1))] + [2k + (2k+1) + \dots + (2k + (k-1))] = k^2 + [(k-1)(k)/2] + k(2k) + [(k-1)(k)/2] = 3k^2 + (k-1)k = 4k^2 - k$ .

22. Let  $n$  be one such integer. Then  $5n - 4 = 6s$  and  $7n + 1 = 4t$ , for some  $s, t \in \mathbb{Z}$ . Since  $2|4$  and  $2|6$ , it follows that  $2|5n$  because  $5n - 4 = 6s$ . From Lemma 4.2 we have  $2|n$ . Consequently, as  $7n + 1 = 4t$ , we find that  $2|1$ . This contradiction tells us that no such integer  $n$  exists.

23. (a) The result is true for  $a = 1$ , so consider  $a > 1$ . From the Fundamental Theorem of Arithmetic we can write  $a = p_1^{e_1} p_2^{e_2} \dots p_t^{e_t}$ , where  $p_1, p_2, \dots, p_t$  are  $t$  distinct primes and  $e_i > 0$ , for all  $1 \leq i \leq t$ . Since  $a^2|b^2$  it follows that  $p_i^{2e_i}|b^2$  for all  $1 \leq i \leq t$ . So  $b^2 = p_1^{2f_1} p_2^{2f_2} \dots p_t^{2f_t} c^2$ , where  $f_i \geq e_i$  for all  $1 \leq i \leq t$ , and  $b = p_1^{f_1} p_2^{f_2} \dots p_t^{f_t} c = a(p_1^{f_1 - e_1} p_2^{f_2 - e_2} \dots p_t^{f_t - e_t})c$ , where  $f_i - e_i \geq 0$  for all  $1 \leq i \leq t$ . Consequently,  $a|b$ .

(b) This result is not necessarily true! Let  $a = 8$  and  $b = 4$ . Then  $a^2 (= 64)$  divides  $b^2 (= 16)$ , but  $a$  does not divide  $b$ .

24. Proof: Suppose that  $n > 1$ . If  $n$  is not prime, then  $n = n_1 n_2$  where  $1 < n_1 < n$  and  $1 < n_2 < n$ . Since  $n|n$  we have  $n|n_1 n_2$ . So  $n|n_1$  or  $n|n_2$  — where either result is impossible.

25. (a) Recall that

$$\begin{aligned} a^3 + b^3 &= (a+b)(a^2 - ab + b^2) \\ a^5 + b^5 &= (a+b)(a^4 - a^3b + a^2b^2 - ab^3 + b^4) \\ &\vdots \\ a^p + b^p &= (a+b)(a^{p-1} - a^{p-2}b + \dots + b^{p-1}) \\ &= (a+b) \sum_{i=1}^p a^{p-i} (-b)^{i-1}, \end{aligned}$$

for  $p$  an odd prime.

Since  $k$  is not a power of 2 we write  $k = r \cdot p$ , where  $p$  is an odd prime and  $r \geq 1$ . Then  $a^k + b^k = (a^r)^p + (b^r)^p = (a^r + b^r) \sum_{i=1}^p a^{r(p-i)} (-b)^{r(i-1)}$ , so  $a^k + b^k$  is composite.

(b) Here  $n$  is not a power of 2. If, in addition,  $n$  is not prime, then  $n = r \cdot p$  where  $p$  is an odd prime. Then  $2^n + 1 = 2^{rp} + 1^p = (2^r)^p + 1^p = (2^r + 1) \sum_{i=1}^p 2^{r(p-i)} (-1)^{r(i-1)} = (2^r + 1) \sum_{i=1}^p 2^{r(p-i)}$ , so  $2^n + 1$  is composite — not prime.

26. Proof: Here the open statement  $S(n)$  represents:  $H_{2^n} \leq 1 + n$ , and for the basis step we consider what happens at  $n = 0$ . We find that  $H_{2^0} = H_{2^0} = H_1 = 1 \leq 1 + 0 = 1 + n$ , so  $S(n)$  is true for this first case (where  $n = 0$ ).

Assuming the truth of  $S(k)$  for some  $k$  in  $\mathbf{N}$  (not just  $\mathbf{Z}^+$ ), we obtain the induction hypothesis

$$S(k): H_{2^k} \leq 1 + k.$$

Continuing with the inductive step we now examine  $S(n)$  for  $n = k + 1$ . We find that

$$\begin{aligned} H_{2^{k+1}} &= \left[1 + \frac{1}{2} + \frac{1}{3} + \dots + \frac{1}{2^k}\right] + \left[\frac{1}{(2^k+1)} + \frac{1}{(2^k+2)} + \dots + \frac{1}{(2^k+2^k)}\right] \\ &= H_{2^k} + \left[\frac{1}{(2^k+1)} + \frac{1}{(2^k+2)} + \dots + \frac{1}{(2^k+2^k)}\right]. \end{aligned}$$

Since  $\frac{1}{(2^k+j)} < \frac{1}{2^k}$ , for all  $1 \leq j \leq 2^k$ , it follows that

$$H_{2^{k+1}} \leq H_{2^k} + (2^k) \left(\frac{1}{2^k}\right) = H_{2^k} + 1.$$

And now from the induction hypothesis we deduce that

$$H_{2^{k+1}} \leq H_{2^k} + 1 \leq (1 + k) + 1 = 1 + (k + 1),$$

so the result  $S(n)$  is true for all  $n \in \mathbf{N}$  — by virtue of the Principle of Mathematical Induction.

27. Proof: For  $n = 0$  we find that  $F_0 = 0 \leq 1 = (5/3)^0$ , and for  $n = 1$  we have  $F_1 = 1 \leq (5/3) = (5/3)^1$ . Consequently, the given property is true in these first two cases (and this provides the basis step of the proof).

Assuming that this property is true for  $n = 0, 1, 2, \dots, k - 1, k$ , where  $k \geq 1$ , we now examine what happens at  $n = k + 1$ . Here we find that

$$F_{k+1} = F_k + F_{k-1} \leq (5/3)^k + (5/3)^{k-1} = (5/3)^{k-1}[(5/3) + 1] = (5/3)^{k-1}(8/3) \\ = (5/3)^{k-1}(24/9) \leq (5/3)^{k-1}(25/9) = (5/3)^{k-1}(5/3)^2 = (5/3)^{k+1}.$$

It then follows from the Alternative Form of the Principle of Mathematical Induction that  $F_n \leq (5/3)^n$  for all  $n \in \mathbf{N}$ .

28. Proof: When  $n = 0$  we find that

$$L_0 = \sum_{i=0}^0 L_i = 2 = 3 - 1 = L_2 - 1 = L_{0+2} - 1,$$

so the claim is established in this first case.

For some  $k \in \mathbf{N}$ , where  $k \geq 0$ , now we assume true that

$$L_0 + L_1 + L_2 + \cdots + L_k = \sum_{i=0}^k L_i = L_{k+2} - 1.$$

Then for  $n = k + 1 (\geq 1)$  we have

$$(*) \quad \sum_{i=0}^{k+1} L_i = \sum_{i=0}^k L_i + L_{k+1} = (L_{k+2} - 1) + L_{k+1} = (L_{k+2} + L_{k+1}) - 1 = L_{k+3} - 1 = L_{(k+1)+2} - 1,$$

and so we see how the truth at  $n = k$  implies that at  $k + 1$ . Consequently, the summation formula is valid for all  $n \in \mathbf{N}$  by the Principle of Mathematical Induction.

[Note that for the equations at (\*), the first equality follows from the generalized associative law of addition — and the fourth equality rests upon the given recursive definition of the Lucas numbers since  $k + 3 \geq 3 (\geq 2)$ .]

29. a) There are  $9 \cdot 10 \cdot 10 = 900$  such palindromes and their sum is  $\sum_{a=1}^9 \sum_{b=0}^9 \sum_{c=0}^9 abcba = \sum_{a=1}^9 \sum_{b=0}^9 \sum_{c=0}^9 (10001a + 1010b + 100c) = \sum_{a=1}^9 \sum_{b=0}^9 [10(10001a + 1010b) + 100(9 \cdot 10/2)] = \sum_{a=1}^9 \sum_{b=0}^9 (100010a + 10100b + 4500) = \sum_{a=1}^9 [10(100010a) + 10100(9 \cdot 10/2) + 10(4500)] = 1000100 \sum_{a=1}^9 a + 9(454500) + 9(45000) = 1000100(9 \cdot 10/2) + 4090500 + 405000 = 49,500,000.$

b) begin

    sum := 0

    for a := 1 to 9 do

        for b := 0 to 9 do

            for c := 0 to 9 do

                sum := sum + 10001 \* a + 1010 \* b + 100 \* c

    print sum

end

30. Proof: Let  $c = \gcd(a, b)$ ,  $d = \gcd(\frac{a-b}{2}, b)$ . Since  $a, b$  are odd, it follows that  $a - b$  is even and  $a - b = 2(\frac{a-b}{2})$ , with  $\frac{a-b}{2} \in \mathbf{Z}^+$ . Also,  $c$  is odd since  $a, b$  are odd. Now  $c = \gcd(a, b) \Rightarrow c \mid a$  and  $c \mid b \Rightarrow c \mid (a - b) \Rightarrow c \mid (\frac{a-b}{2})$  because  $\gcd(2, c) = 1$ . Consequently,  $c \mid b$  and  $c \mid (\frac{a-b}{2}) \Rightarrow c \mid d$ . As  $d = \gcd(\frac{a-b}{2}, b)$ , it follows that  $d \mid 2(\frac{a-b}{2}) + b$ , that is,  $d \mid a$ . Since  $d \mid a$  and  $d \mid b$ , we have  $d \mid c$ . Since  $c \mid d$  and  $d \mid c$  and  $c, d > 0$ , it follows that  $c = d$ .
31. Proof: Suppose that  $7 \mid n$ . We see that  $7 \mid n \Rightarrow 7 \mid (n - 21u) \Rightarrow 7 \mid [(n - u) - 20u] \Rightarrow 7 \mid [10(\frac{n-u}{10}) - 20u] \Rightarrow 7 \mid [10(\frac{n-u}{10} - 2u)] \Rightarrow 7 \mid (\frac{n-u}{10} - 2u)$ , by Lemma 4.2 since  $\gcd(7, 10) = 1$ . [Note:  $\frac{n-u}{10} \in \mathbf{Z}^+$  since the units digit of  $n - u$  is 0.] Conversely, if  $7 \mid (\frac{n-u}{10} - 2u)$ , then since  $\frac{n-u}{10} - 2u = \frac{n-21u}{10}$  we find that  $7 \mid (\frac{n-21u}{10}) \Rightarrow 7 \cdot 10 \cdot x = n - 21u$ , for some  $x \in \mathbf{Z}^+$ . Since  $7 \mid 7$  and  $7 \mid 21$ , it then follows that  $7 \mid n$  - by part (e) of Theorem 4.3.
32. a) If  $19m + 90 + 8n = 1998$ , then  $m = (1/19)(1908 - 8n)$ . Since  $1908 = 19(100) + 8$ , the remainder for  $8n/19$  must be 8. This occurs for  $n = 1$ , and then  $m = (1/19)(1908 - 8) = (1/19)(1900) = 100$ .  
b) In a similar way we have  $n = (1/8)(1908 - 19m)$ . Here  $1908 = 8(238) + 4$ , so the remainder for  $19m/8$  must be 4. This occurs for  $m = 4$  (and *not* for  $m = 1, 2$ , or  $3$ ), and then  $n = (1/8)(1908 - 76) = 229$ .
33. If Catrina's selection includes any of 0, 2, 4, 6, 8, then at least two of the resulting three-digit integers will have an even unit's digit, and be even - hence, *not* prime. Should her selection include 5, then two of the resulting three-digit integers will have 5 as their unit's digit; these three-digit integers are then divisible by 5 and so, they are *not* prime. Consequently, to complete the proof we need to consider the four selections of size 3 that Catrina can make from  $\{1, 3, 7, 9\}$ . The following provides the selections - each with a three-digit integer that is not prime.
- (1)  $\{1, 3, 7\} : 713 = 23 \cdot 31$   
 (2)  $\{1, 3, 9\} : 913 = 11 \cdot 83$   
 (3)  $\{1, 7, 9\} : 917 = 7 \cdot 131$   
 (4)  $\{3, 7, 9\} : 793 = 13 \cdot 61$
34. Let  $T = \{a, b, c, d, e, f, g, h\}$  represent the eight element subset of  $\{2, 3, 4, 7, 10, 11, 12, 13, 15\}$  that we use.
- |     |     |     |     |
|-----|-----|-----|-----|
| $a$ | $b$ | 14  | $c$ |
| $d$ | 5   | $e$ | 9   |
| 1   | $f$ | $g$ | $h$ |
- These numbers are placed in the table as shown in the figure. Since each row has the same average, it follows that  $\frac{a+b+14+c}{4} = \frac{d+5+e+9}{4} = \frac{1+f+g+h}{4}$ . Likewise, from the columns of the table we learn that  $\frac{a+d+1}{3} = \frac{b+5+f}{3} = \frac{14+e+g}{3} = \frac{c+9+h}{3}$ . Consequently, both 3 and 4 divide  $s = (a + b + c + d + e + f + g + h + 29)$ , and since  $\gcd(3, 4) = 1$  it follows that 12 divides  $s$ . So we may write  $s = 12k$ . The total of the nine given integers is 77. If we let  $i$  denote

the integer not in  $T$ , then  $s = (77 - i) + 29$  so  $77 - i + 29 = 12k$ , or  $106 - i = 12k$ .

As we examine the nine given integers we see that

$$\begin{array}{lll} 106 - 2 = 104 = 12(8) + 8 & 106 - 7 = 99 = 12(8) + 3 & 106 - 12 = 94 = 12(7) + 10 \\ 106 - 3 = 103 = 12(8) + 7 & 106 - 10 = 96 = 12(8) & 106 - 13 = 93 = 12(7) + 9 \\ 106 - 4 = 102 = 12(8) + 6 & 106 - 11 = 95 = 12(7) + 11 & 106 - 15 = 91 = 12(7) + 7 \end{array}$$

Therefore we do not place 10 in the table. So  $T = \{2, 3, 4, 7, 11, 12, 13, 15\}$  and the 12 entries in the table total  $67 + 29 = 96$ . It then follows that  $a + b + 14 + c = d + 5 + e + 9 = 1 + f + g + h = 32$  and  $a + d + 1 = b + 5 + f = 14 + e + g = c + 9 + h = 24$ .

From column 3 we have  $14 + e + g = 24$ , so  $e + g = 10$ . The entries in  $T$  imply that  $\{e, g\} = \{3, 7\}$ ;  $e = 3 \Rightarrow d = 15$  (from the equation  $d + 5 + e + 9 = 32$ ). With  $d = 15$ , from  $a + d + 1 = 24$  we have  $a = 8$ , but  $8 \notin T$ . Consequently,  $e = 7$  and  $g = 3$ , and then  $d = 32 - 21 = 11$ . Column 1 indicates that  $a + d + 1 = 24$  so  $a = 12$ . From column 2 it follows that  $b + f = 19$ , so  $\{b, f\} = \{4, 15\}$ . As  $b = 15 \Rightarrow a + b + 14 + c > 32$ , it follows that  $b = 4$  and  $f = 15$ . Row 1 then indicates that  $c = 32 - a - b - 14 = 2$  and from row 3 (or column 4) we deduce that  $h = 13$ . The completed table is shown in the figure.

12	4	14	2
11	5	7	9
1	15	3	13

35. Let  $x$  denote the integer Barbara erased. The sum of the integers  $1, 2, 3, \dots, x - 1, x + 1, x + 2, \dots, n$  is  $[n(n + 1)/2] - x$ , so  $[[n(n + 1)/2] - x]/(n - 1) = 35\frac{7}{17}$ . Consequently,  $[n(n + 1)/2] - x = (35\frac{7}{17})(n - 1) = (602/17)(n - 1)$ . Since  $[n(n + 1)/2] - x \in \mathbf{Z}^+$ , it follows that  $(602/17)(n - 1) \in \mathbf{Z}^+$ . Therefore, from Lemma 4.2, we find that  $17|(n - 1)$  because 17 does not divide 602. For  $n = 1, 18, 35, 52$  we have:

$n$	$x = [n(n + 1)/2] - (602/17)(n - 1)$
1	1
18	-431
35	-574
52	-428

When  $n = 69$ , we find that  $x = 7$  [and  $(\sum_{i=1}^{69} i - 7)/68 = 602/17 = 35\frac{7}{17}$ ].

For  $n = 69 + 17k$ ,  $k \geq 1$ , we have

$$\begin{aligned} x &= [(69 + 17k)(70 + 17k)/2] - (602/17)[68 + 17k] \\ &= 7 + (k/2)[1159 + 289k] \\ &= [7 + (1159k/2)] + (289k^2)/2 > n. \end{aligned}$$

Hence the answer is unique: namely,  $n = 69$  and  $x = 7$ .

36. Let  $S = \{1, 2, 3, \dots, 100\}$  be the sample space for this experiment and let  $A, B, C$  denote the following events:

$A$ : Leslie's selection is divisible by 2:  $\{2, 4, 6, \dots, 98, 100\}$

$B$ : Leslie's selection is divisible by 3:  $\{3, 6, 9, \dots, 96, 99\}$

$C$ : Leslie's selection is divisible by 5:  $\{5, 10, 15, \dots, 95, 100\}$

(a)  $Pr(A \cup B) = Pr(A) + Pr(B) - Pr(A \cap B) = \frac{50}{100} + \frac{33}{100} - \frac{16}{100} = \frac{67}{100} = 0.67$ . [Note: Here  $A \cap B = \{6, 12, 18, \dots, 96\}$ , the set of integers between 1 and 100 (inclusive) that are divisible by 6 – that is, divisible by both 2 and 3.]

(b)  $Pr(A \cup B \cup C) = Pr(A) + Pr(B) + Pr(C) - Pr(A \cap B) - Pr(A \cap C) - Pr(B \cap C) + Pr(A \cap B \cap C) = \frac{50}{100} + \frac{33}{100} + \frac{20}{100} - \frac{16}{100} - \frac{10}{100} - \frac{6}{100} + \frac{3}{100} = \frac{74}{100} = 0.74$ .

37. A common divisor for  $m, n$  has the form  $p_1^{r_1} p_2^{r_2} p_3^{r_3}$ , where  $0 \leq r_i \leq \min\{e_i, f_i\}$ , for all  $1 \leq i \leq 3$ . Let  $m_i = \min\{e_i, f_i\}$ ,  $1 \leq i \leq 3$ . Then the number of common divisors is  $(m_1 + 1)(m_2 + 1)(m_3 + 1)$ .

CHAPTER 5  
RELATIONS AND FUNCTIONS

**Section 5.1**

1.  $A \times B = \{(1, 2), (2, 2), (3, 2), (4, 2), (1, 5), (2, 5), (3, 5), (4, 5)\}$   
 $B \times A = \{(2, 1), (2, 2), (2, 3), (2, 4), (5, 1), (5, 2), (5, 3), (5, 4)\}$   
 $A \cup (B \times C) = \{1, 2, 3, 4, (2, 3), (2, 4), (2, 7), (5, 3), (5, 4), (5, 7)\}$   
 $(A \cup B) \times C = (A \times C) \cup (B \times C) = \{(1, 3), (2, 3), (3, 3), (4, 3), (5, 3), (1, 4), (2, 4), (3, 4), (4, 4), (5, 4), (1, 7), (2, 7), (3, 7), (4, 7), (5, 7)\}$
2. (a)  $\{(1, 2)\}; \{(1, 2), (1, 4), (1, 5), (2, 2), (2, 4)\}; A \times B$   
 (b)  $\{(1, 1), (2, 2), (3, 3)\}; \{(1, 1), (1, 2), (1, 3), (2, 2), (3, 3)\}; \{(1, 2), (2, 1), (3, 3)\}$ .
3. (a)  $|A \times B| = |A||B| = 9$   
 (b) Since a relation from  $A$  to  $B$  is a subset of  $A \times B$ , there are  $2^9$  relations from  $A$  to  $B$ .  
 (c) Since  $|A \times A| = 9$ , there are  $2^9$  relations on  $A$ .  
 (d) For the other seven ordered pairs in  $A \times B$  there are two choices: include it in the relation or leave it out. Hence there are  $2^7$  relations from  $A$  to  $B$  that contain  $(1, 2)$  and  $(1, 5)$ .  
 (e)  $\binom{9}{5}$  (f)  $\binom{9}{7} + \binom{9}{8} + \binom{9}{9}$
4. If either  $A$  or  $B$  is  $\emptyset$  and when  $A = B$ .
5. (a) Assume that  $A \times B \subseteq C \times D$  and let  $a \in A$  and  $b \in B$ . Then  $(a, b) \in A \times B$ , and since  $A \times B \subseteq C \times D$  we have  $(a, b) \in C \times D$ . But  $(a, b) \in C \times D \Rightarrow a \in C$  and  $b \in D$ . Hence,  $a \in A \Rightarrow a \in C$ , so  $A \subseteq C$ , and  $b \in B \Rightarrow b \in D$ , so  $B \subseteq D$ .  
 Conversely, suppose that  $A \subseteq C$  and  $B \subseteq D$ , and that  $(x, y) \in A \times B$ . Then  $(x, y) \in A \times B \Rightarrow x \in A$  and  $y \in B \Rightarrow x \in C$  (since  $A \subseteq C$ ) and  $y \in D$  (since  $B \subseteq D$ )  $\Rightarrow (x, y) \in C \times D$ . Consequently,  $A \times B \subseteq C \times D$ .

(b) If any of the sets  $A, B, C, D$  is empty we still find that

$$[(A \subseteq C) \wedge (B \subseteq D)] \Rightarrow [A \times B \subseteq C \times D].$$

However, the converse need not hold. For example, let  $A = \emptyset$ ,  $B = \{1, 2\}$ ,  $C = \{1, 2\}$  and  $D = \{1\}$ . Then  $A \times B = \emptyset$  — if not, there exists an ordered pair  $(x, y)$  in  $A \times B$ , and this means that the empty set  $A$  contains an element  $x$ . And so  $A \times B = \emptyset \subseteq C \times D$  — but  $B = \{1, 2\} \not\subseteq \{1\} = D$ .

6.

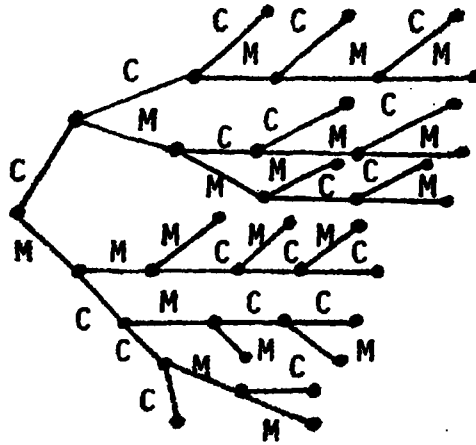

7. (a) Since  $|A| = 5$  and  $|B| = 4$  we have  $|A \times B| = |A||B| = 5 \cdot 4 = 20$ . Consequently,  $A \times B$  has  $2^{20}$  subsets, so  $|\mathcal{P}(A \times B)| = 2^{20}$ .

(b) If  $|A| = m$  and  $|B| = n$ , for  $m, n \in \mathbb{N}$ , then  $|A \times B| = mn$ . Consequently,  $|\mathcal{P}(A \times B)| = 2^{mn}$ .

8.

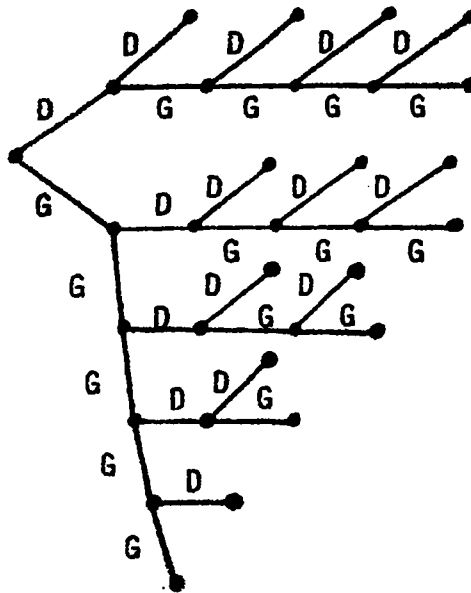

9. (b)  $A \times (B \cup C) = \{(x, y) | x \in A \text{ and } y \in (B \cup C)\} = \{(x, y) | x \in A \text{ and } (y \in B \text{ or } y \in C)\} = \{(x, y) | (x \in A \text{ and } y \in B) \text{ or } (x \in A \text{ and } y \in C)\} = \{(x, y) | x \in A \text{ and } y \in B\} \cup \{(x, y) | x \in A \text{ and } y \in C\} = (A \times B) \cup (A \times C).$   
(c) & (d) The proofs here are similar to that given in part (b).
10.  $1 + 2 + 2(3) + 2(3)(5) = 39; 38$
11.  $(x, y) \in A \times (B - C) \iff x \in A \text{ and } y \in B - C \iff x \in A \text{ and } (y \in B \text{ and } y \notin C) \iff (x \in A \text{ and } y \in B) \text{ and } (x \in A \text{ and } y \notin C) \iff (x, y) \in A \times B \text{ and } (x, y) \notin A \times C \iff (x, y) \in (A \times B) - (A \times C).$
12.  $2^{(3|B|)} = 4096 \implies 3|B| = 12 \implies |B| = 4.$
13. (a) (1)  $(0, 2) \in \mathcal{R}$ ; and  
(2) If  $(a, b) \in \mathcal{R}$ , then  $(a + 1, b + 5) \in \mathcal{R}.$   
(b) From part (1) of the definition we have  $(0, 2) \in \mathcal{R}.$  By part (2) of the definition we then find that  
(i)  $(0, 2) \in \mathcal{R} \implies (0 + 1, 2 + 5) = (1, 7) \in \mathcal{R};$   
(ii)  $(1, 7) \in \mathcal{R} \implies (1 + 1, 7 + 5) = (2, 12) \in \mathcal{R};$   
(iii)  $(2, 12) \in \mathcal{R} \implies (2 + 1, 12 + 5) = (3, 17) \in \mathcal{R};$  and  
(iv)  $(3, 17) \in \mathcal{R} \implies (3 + 1, 17 + 5) = (4, 22) \in \mathcal{R}.$
14. (a) (1)  $(1, 1), (2, 1) \in \mathcal{R}$ ; and  
(2) If  $(a, b) \in \mathcal{R}$ , then  $(a + 1, b + 1)$  and  $(a + 1, b)$  are in  $\mathcal{R}.$   
(b) Start with  $(2, 1)$  in  $\mathcal{R}$  — from part (1) of the definition. Then by part (2) we get  
(i)  $(2, 1) \in \mathcal{R} \implies (2 + 1, 1 + 1) = (3, 2) \in \mathcal{R};$   
(ii)  $(3, 2) \in \mathcal{R} \implies (3 + 1, 2) = (4, 2) \in \mathcal{R};$  and  
(iii)  $(4, 2) \in \mathcal{R} \implies (4 + 1, 2) = (5, 2) \in \mathcal{R}.$   
Start with  $(1, 1)$  in  $\mathcal{R}$  — from part (1) of the definition. Then we find from part (2) that  
(i)  $(1, 1) \in \mathcal{R} \implies (1 + 1, 1 + 1) = (2, 2) \in \mathcal{R};$   
(ii)  $(2, 2) \in \mathcal{R} \implies (2 + 1, 2 + 1) = (3, 3) \in \mathcal{R};$  and  
(iii)  $(3, 3) \in \mathcal{R} \implies (3 + 1, 3 + 1) = (4, 4) \in \mathcal{R}.$

## Section 5.2

1. (a) Function: Range =  $\{7, 8, 11, 16, 23, \dots\}$   
(b) Relation, not a function. For example, both  $(4, 2)$  and  $(4, -2)$  are in the relation.  
(c) Function: Range = the set of all real numbers.  
(d) Relation, not a function. Both  $(0, 1)$  and  $(0, -1)$  are in the relation.  
(e) Since  $|R| > 5$ ,  $R$  cannot be a function.
2. The formula cannot be used for the domain of real numbers since  $f(\sqrt{2}), f(-\sqrt{2})$  are undefined. Since  $\sqrt{2}, -\sqrt{2} \notin \mathbf{Z}$  the formula does define a real valued function on the domain  $\mathbf{Z}.$

3. (a)  $\{(1, x), (2, x), (3, x), (4, x)\}, \{(1, y), (2, y), (3, y), (4, y)\}, \{(1, z), (2, z), (3, z), (4, z)\}$   
 $\{(1, x), (2, y), (3, x), (4, y)\}, \{(1, x), (2, y), (3, z), (4, x)\}$   
 (b)  $3^4$  (c) 0 (d)  $4^3$  (e) 24 (f)  $3^3$  (g)  $3^2$  (h)  $3^2$

4.  $3^{|A|} = 2187 \implies |A| = 7$

5. (a)  $A \cap B = \{(x, y) | y = 2x + 1 \text{ and } y = 3x\}$

$$2x + 1 = 3x \implies x = 1$$

$$\text{So } A \cap B = \{(1, 3)\}.$$

(b)  $B \cap C = \{(x, y) | y = 3x \text{ and } y = x - 7\}$

$$3x = x - 7 \implies 2x = -7, \text{ so } x = -7/2.$$

$$\text{Consequently, } B \cap C = \{(-7/2, 3(-7/2))\} = \{(-7/2, -21/2)\}.$$

(c)  $\overline{A \cup C} = \overline{A} \cap \overline{C} = A \cap C = \{(x, y) | y = 2x + 1 \text{ and } y = x - 7\}$

$$\text{Now } 2x + 1 = x - 7 \implies x = -8, \text{ and so } A \cap C = \{(-8, -15)\}.$$

(d) We know that  $\overline{B \cup C} = \overline{B} \cap \overline{C}$ , and since  $B \cap C = \{(-7/2, -21/2)\}$  we have  $\overline{B \cup C} = \mathbb{R}^2 - \{(-7/2, -21/2)\} = \{(x, y) | x \neq -7/2 \text{ or } y \neq -21/2\}.$

6.

(a) (i)  $A \cap B = \{(1, 3)\}$

(ii)  $B \cap C = \{\} = \emptyset$

(iii)  $\overline{A \cup C} = \{(-8, -15)\}$

(iv)  $\overline{B \cup C} = \mathbb{Z}^2 = \mathbb{Z} \times \mathbb{Z}$

(b) (i)  $A \cap B = \{(1, 3)\}$

(ii)  $B \cap C = \{\} = \emptyset$

(iii)  $\overline{A \cup C} = \emptyset$

(iv)  $\overline{B \cup C} = \mathbb{Z}^+ \times \mathbb{Z}^+$

7.

(a)  $\lfloor 2.3 - 1.6 \rfloor = \lfloor 0.7 \rfloor = 0$

(b)  $\lfloor 2.3 \rfloor - \lfloor 1.6 \rfloor = 2 - 1 = 1$

(c)  $\lceil 3.4 \rceil \lceil 6.2 \rceil = 4 \cdot 6 = 24$

(d)  $\lceil 3.4 \rceil \lceil 6.2 \rceil = 3 \cdot 7 = 21$

(e)  $\lfloor 2\pi \rfloor = 6$

(f)  $2\lceil \pi \rceil = 8$

8. (a) True

(b) False: Let  $a = 1.5$ . Then  $\lfloor 1.5 \rfloor = 1 \neq 2 = \lceil 1.5 \rceil$

(c) True

(d) False: Let  $a = 1.5$ . Then  $-\lceil a \rceil = -2 \neq -1 = \lfloor -a \rfloor$ .

9. (a)  $\dots \lfloor -1, -6/7 \rfloor \cup \lfloor 0, 1/7 \rfloor \cup \lfloor 1, 8/7 \rfloor \cup \lfloor 2, 15/7 \rfloor \cup \dots$

(b)  $\lfloor 1, 8/7 \rfloor$

(c)  $\mathbb{Z}$

(d)  $\mathbb{R}$

10.  $\mathbb{R}$

11. (a)  $\dots \cup (-7/3, -2] \cup (-4/3, -1] \cup (-1/3, 0] \cup (2/3, 1] \cup (5/3, 2] \cup \dots = \bigcup_{m \in \mathbb{Z}^+} (m - 1/3, m]$

(b)  $\dots \cup ((-2n-1)/n, -2] \cup ((-n-1)/n, -1] \cup (-1/n, 0] \cup ((n-1)/n, 1] \cup ((2n-1)/n, 2] \cup \dots$

$$= \bigcup_{m \in \mathbb{Z}^+} (m - 1/n, m]$$

12. Proof: (Case 1:  $k|n$ ) Here  $n = qk$  for  $q \in \mathbf{Z}^+$ , and  $(n-1)/k = (qk-1)/k = q - (1/k)$  with  $q-1 \leq q - (1/k) < q$ . Therefore  $\lceil n/k \rceil = \lceil q \rceil = q = (q-1) + 1 = \lfloor (n-1)/k \rfloor + 1$ .  
 (Case 2:  $k \nmid n$ ) Now we have  $n = qk + r$ , where  $q, r \in \mathbf{Z}^+$  with  $r < k$ , and  $n/k = q + (r/k)$  with  $0 < (r/k) < 1$ . So  $n-1 = qk + (r-1)$  and  $(n-1)/k = q + \lfloor (r-1)/k \rfloor$  with  $0 \leq \lfloor (r-1)/k \rfloor < 1$ . Consequently,  $\lceil n/k \rceil = \lceil q + (r/k) \rceil = q + 1 = \lfloor (n-1)/k \rfloor + 1$ .

13. a) Proof (i): If  $a \in \mathbf{Z}^+$ , then  $\lceil a \rceil = a$  and  $\lfloor \lceil a \rceil / a \rfloor = \lfloor 1 \rfloor = 1$ . If  $a \notin \mathbf{Z}^+$ , write  $a = n + c$ , where  $n \in \mathbf{Z}^+$  and  $0 < c < 1$ . Then  $\lceil a \rceil / a = (n+1)/(n+c) = 1 + (1-c)/(n+c)$ , where  $0 < (1-c)/(n+c) < 1$ . Hence  $\lfloor \lceil a \rceil / a \rfloor = \lfloor 1 + (1-c)/(n+c) \rfloor = 1$ .

Proof (ii): For  $a \in \mathbf{Z}^+$ ,  $\lfloor a \rfloor = a$  and  $\lceil \lfloor a \rfloor / a \rceil = \lceil 1 \rceil = 1$ . When  $a \notin \mathbf{Z}^+$ , let  $a = n + c$ , where  $n \in \mathbf{Z}^+$  and  $0 < c < 1$ . Then  $\lfloor a \rfloor / a = n/(n+c) = 1 - [c/(n+c)]$ , where  $0 < c/(n+c) < 1$ . Consequently  $\lceil \lfloor a \rfloor / a \rceil = \lceil 1 - (c/(n+c)) \rceil = 1$ .

b) Consider  $a = 0.1$ . Then

(i)  $\lfloor \lceil a \rceil / a \rfloor = \lfloor 1/0.1 \rfloor = \lfloor 10 \rfloor = 10 \neq 1$ ; and

(ii)  $\lceil \lfloor a \rfloor / a \rceil = \lceil 0/0.1 \rceil = 0 \neq 1$ .

In fact (ii) is false for all  $0 < a < 1$ , since  $\lceil \lfloor a \rfloor / a \rceil = 0$  for all such values of  $a$ . In the case of (i), when  $0 < a \leq 0.5$ , it follows that  $\lceil a \rceil / a \geq 2$  and  $\lfloor \lceil a \rceil / a \rfloor \geq 2 \neq 1$ . However, for  $0.5 < a < 1$ ,  $\lceil a \rceil / a = 1/a$  where  $1 < 1/a < 2$ , and so  $\lfloor \lceil a \rceil / a \rfloor = 1$  for  $0.5 < a < 1$ .

14.

- (a)  $a_2 = 2a_{\lfloor 2/2 \rfloor} = 2a_1 = 2$   
 $a_3 = 2a_{\lfloor 3/2 \rfloor} = 2a_1 = 2$   
 $a_4 = 2a_{\lfloor 4/2 \rfloor} = 2a_2 = 4$   
 $a_5 = 2a_{\lfloor 5/2 \rfloor} = 2a_2 = 4$   
 $a_6 = 2a_{\lfloor 6/2 \rfloor} = 2a_3 = 4$   
 $a_7 = 2a_{\lfloor 7/2 \rfloor} = 2a_3 = 4$   
 $a_8 = 2a_{\lfloor 8/2 \rfloor} = 2a_4 = 8$

(b) Proof: (By the Alternative Form of the Principle of Mathematical Induction)

For  $n = 1$  we have  $a_1 = 1 \leq 1$ , so the result is true in this first case. (This provides the basis step for the proof.)

Now assume the result true for some  $k \geq 1$  and all  $n = 1, 2, 3, \dots, k-1, k$ . For  $n = k+1$  we have  $a_{k+1} = 2a_{\lfloor (k+1)/2 \rfloor} \leq 2\lfloor (k+1)/2 \rfloor$ , where the inequality follows from the assumption of the induction hypothesis.

When  $k$  is odd, then,  $\lfloor (k+1)/2 \rfloor = (k+1)/2$  and we have  $a_{k+1} \leq 2\lfloor (k+1)/2 \rfloor = k+1$ .

When  $k$  is even, then  $\lfloor (k+1)/2 \rfloor = \lfloor (k/2) + (1/2) \rfloor = (k/2)$ , and here we find that  $a_{k+1} \leq 2(k/2) = k \leq k+1$ .

In either case it follows from  $a_{\lfloor (k+1)/2 \rfloor} \leq \lfloor (k+1)/2 \rfloor$  that  $a_{k+1} \leq k+1$ . So we have established the inductive step of the proof.

Therefore, it follows from the Alternative Form of the Principle of Mathematical Induction that

$$\forall n \in \mathbf{Z}^+ \quad a_n \leq n.$$

15. (a) One-to-one. The range is the set of all odd integers.  
 (b) One-to-one. Range =  $\mathbf{Q}$   
 (c) Since  $f(1) = f(0)$ ,  $f$  is not one-to-one. The range of  $f = \{0, \pm 6, \pm 24, \pm 60, \dots\} = \{n^3 - n \mid n \in \mathbf{Z}\}$ .  
 (d) One-to-one. Range =  $(0, +\infty) = \mathbf{R}^+$   
 (e) One-to-one. Range =  $[-1, 1]$   
 (f) Since  $f(\pi/4) = f(3\pi/4)$ ,  $f$  is not one-to-one. The range of  $f = [0, 1]$ .
16. (a)  $\{4, 9\}$  (b)  $\{4, 9\}$  (c)  $[0, 9]$   
 (d)  $[0, 9]$  (e)  $[0, 49]$  (f)  $[9, 16] \cup [25, 36]$
17. The extension must include  $f(1)$  and  $f(4)$ . Since  $|B| = 4$  there are four choices for each of 1 and 4, so there are  $4^2 = 16$  ways to extend the given function  $g$ .
18. Let  $A = \{1, 2\}$ ,  $B = \{3, 4\}$  and  $f = \{(1, 3), (2, 3)\}$ . For  $A_1 = \{1\}$ ,  $A_2 = \{2\}$ ,  $f(A_1 \cap A_2) = f(\emptyset) = \emptyset$  while  $f(A_1) \cap f(A_2) = \{3\} \cap \{3\} = \{3\}$ .
19. (a)  $f(A_1 \cup A_2) = \{y \in B \mid y = f(x), x \in A_1 \cup A_2\} = \{y \in B \mid y = f(x), x \in A_1 \text{ or } x \in A_2\} = \{y \in B \mid y = f(x), x \in A_1\} \cup \{y \in B \mid y = f(x), x \in A_2\} = f(A_1) \cup f(A_2)$ .  
 (c)  $y \in f(A_1) \cap f(A_2) \implies y = f(x_1) = f(x_2), x_1 \in A_1, x_2 \in A_2 \implies y = f(x_1)$  with  $x_1 = x_2$ , since  $f$  is one-to-one  $\implies y \in f(A_1 \cap A_2)$ .
20. The number of injective (or, one-to-one) functions from  $A$  to  $B$  is  $(|B|!)/(|B| - 5)! = 6720$ , and  $|B| = 8$ .
21. No. Let  $A = \{1, 2\}$ ,  $X = \{1\}$ ,  $Y = \{2\}$ ,  $B = \{3\}$ . For  $f = \{(1, 3), (2, 3)\}$  we have  $f|_X, f|_Y$  one-to-one, but  $f$  is not one-to-one.
22. (a) A monotone increasing function  $f : X_7 \rightarrow X_5$  determines a selection, with repetitions allowed, of size 7 from  $\{1, 2, 3, 4, 5\}$ , and vice versa. For example, the selection 1, 1, 2, 2, 3, 5, 5 corresponds to the monotone increasing function  $g : X_7 \rightarrow X_5$ , where  $g = \{(1, 1), (2, 1), (3, 2), (4, 2), (5, 3), (6, 5), (7, 5)\}$ . (Note the second components.) Consequently, the number of monotone increasing functions  $f : X_7 \rightarrow X_5$  is  $\binom{5+7-1}{7} = \binom{11}{7} = 330$ .  
 (b)  $\binom{5+6-1}{6} = \binom{14}{6} = 3003$ .  
 (c) For  $m, n \in \mathbf{Z}^+$ , the number of monotone increasing functions  $f : X_m \rightarrow X_n$  is  $\binom{n+m-1}{m}$ .  
 (d) Since  $f(4) = 4$ , it follows that  $f(\{1, 2, 3\}) \subseteq \{1, 2, 3, 4\}$  and  $f(\{5, 6, 7, 8, 9, 10\}) \subseteq \{4, 5, 6, 7, 8\}$  because  $f$  is monotone increasing. The number of these functions is  $\binom{4+3-1}{3} \binom{5+6-1}{6} = \binom{6}{3} \binom{10}{6} = (20)(210) = 4200$ .  
 (e)  $\binom{12}{4} \binom{5}{2} = 4950$ .  
 (f) Let  $m, n, k, \ell \in \mathbf{Z}^+$  with  $1 \leq k \leq m$  and  $1 \leq \ell \leq n$ . If  $f : X_m \rightarrow X_n$  is monotone

increasing and  $f(k) = \ell$ , then  $f(\{1, 2, \dots, k-1\}) \subseteq \{1, 2, \dots, \ell\}$  and  $f(\{k+1, \dots, m\}) \subseteq \{\ell, \ell+1, \dots, n\}$ . So there are

$$\binom{\ell+(k-1)-1}{(k-1)} \binom{(n-\ell+1)+(m-(k+1)+1)-1}{(m-(k+1)+1)} = \binom{\ell+k-2}{k-1} \binom{n+m-\ell-k}{m-k} \text{ such functions.}$$

23. (a)  $f(a_{ij}) = 12(i-1) + j$       (b)  $f(a_{ij}) = 10(i-1) + j$       (c)  $f(a_{ij}) = 7(i-1) + j$
24.  $g(a_{ij}) = m(j-1) + i$
25. (a) (i)  $f(a_{ij}) = n(i-1) + (k-1) + j$   
(ii)  $g(a_{ij}) = m(j-1) + (k-1) + i$   
(b)  $k + (mn-1) \leq r$
26. (a) There is only one function in  $S_1$ , namely  $f : A \rightarrow B$  where  $f(a) = f(b) = 1$  and  $f(c) = 2$ . Hence  $|S_1| = 1$ .  
(b) Since  $f(c) = 3$  we have two choices — namely 1, 2 — for each of  $f(a)$  and  $f(b)$ . Consequently,  $|S_2| = 2^2$ .  
(c) With  $f(c) = i+1$  there are  $i$  choices — namely  $1, 2, 3, \dots, i-1, i$  — for each of  $f(a)$  and  $f(b)$ , so  $|S_i| = i^2$ .  
(d) Any function  $f$  in  $T_1$  is determined by two elements  $x, y$  in  $B$ , where  $1 \leq x < y \leq n+1$  and  $f(a) = f(b) = x$ ,  $f(c) = y$ . We can select these two elements from  $B$  in  $\binom{n+1}{2}$  ways, so  $|T_1| = \binom{n+1}{2}$ .  
(e) For  $T_2$  we have  $f(a) < f(b) < f(c)$ , so we need three distinct elements from  $B$ , and these can be chosen in  $\binom{n+1}{3}$  ways. The argument for  $T_3$  is similar.  
(f)  $S = S_1 \cup S_2 \cup S_3 \cup \dots \cup S_n$ , where  $S_i \cap S_j = \emptyset$  for all  $1 \leq i < j \leq n$ , and  $S = T_1 \cup T_2 \cup T_3$  with  $T_1 \cap T_2 = T_1 \cap T_3 = T_2 \cap T_3 = \emptyset$ .  
(g) From part (f) we have  $|S| = \sum_{i=1}^n |S_i| = \sum_{i=1}^n i^2 = \sum_{j=1}^3 |T_j| = \binom{n+1}{2} + 2\binom{n+1}{3}$ . Hence

$$\sum_{i=1}^n i^2 = (n+1)(n)/2 + 2(n+1)(n)(n-1)/6 = (n+1)(n)[(1/2) + (n-1)/3] = (n+1)(n)[(3+2n-2)/6] = n(n+1)(2n+1)/6.$$

27. (a)  $A(1, 3) = A(0, A(1, 2)) = A(1, 2) + 1 = A(0, A(1, 1)) + 1 = [A(1, 1) + 1] + 1 = A(1, 1) + 2 = A(0, A(1, 0)) + 2 = [A(1, 0) + 1] + 2 = A(1, 0) + 3 = A(0, 1) + 3 = (1+1) + 3 = 5$

$$A(2, 3) = A(1, A(2, 2))$$

$$A(2, 2) = A(1, A(2, 1))$$

$$A(2, 1) = A(1, A(2, 0)) = A(1, A(1, 1))$$

$$A(1, 1) = A(0, A(1, 0)) = A(1, 0) + 1 = A(0, 1) + 1 = (1+1) + 1 = 3$$

$$A(2, 1) = A(1, 3) = A(0, A(1, 2)) = A(1, 2) + 1 = A(0, A(1, 1)) = [A(1, 1) + 1] + 1 = 5$$

$$A(2, 2) = A(1, 5) = A(0, A(1, 4)) = A(1, 4) + 1 = A(0, A(1, 3)) + 1 = A(1, 3) + 2 = A(0, A(1, 2)) + 2 = A(1, 2) + 3 = A(0, A(1, 1)) + 3 = A(1, 1) + 4 = 7$$

$$A(2, 3) = A(1, 7) = A(0, A(1, 6)) = A(1, 6) + 1 = A(0, A(1, 5)) + 1 = A(0, 7) + 1 = (7+1) + 1 = 9$$

(b) Since  $A(1, 0) = A(0, 1) = 2 = 0 + 2$ , the result holds for the case where  $n = 0$ . Assuming the truth of the (open) statement for some  $k (\geq 0)$  we have  $A(1, k) = k + 2$ . Then we find that  $A(1, k + 1) = A(0, A(1, k)) = A(1, k) + 1 = (k + 2) + 1 = (k + 1) + 2$ , so the truth at  $n = k$  implies the truth at  $n = k + 1$ . Consequently,  $A(1, n) = n + 2$  for all  $n \in \mathbf{N}$  by the Principle of Mathematical Induction.

(c) Here we find that  $A(2, 0) = A(1, 1) = 1 + 2 = 3$  (by the result in part(b)). So  $A(2, 0) = 3 + 2 \cdot 0$  and the given (open) statement is true in this first case.

Next we assume the result true for some  $k (\geq 0)$  — that is, we assume that  $A(2, k) = 3 + 2k$ . For  $k + 1$  we then find that  $A(2, k + 1) = A(1, A(2, k)) = A(2, k) + 2$  (by part (b)) =  $(3 + 2k) + 2$  (by the induction hypothesis) =  $3 + 2(k + 1)$ . Consequently, for all  $n \in \mathbf{N}$ ,  $A(2, n) = 3 + 2n$  — by the Principle of Mathematical Induction.

(d) Once again we consider what happens for  $n = 0$ . Since  $A(3, 0) = A(2, 1) = 3 + 2(1)$  (by part (c)) =  $5 = 2^{0+3} - 3$ , the result holds in this first case.

So now we assume the given (open) statement is true for some  $k (\geq 0)$  and this gives us the induction hypothesis:  $A(3, k) = 2^{k+3} - 3$ . For  $n = k + 1$  it then follows that  $A(3, k + 1) = A(2, A(3, k)) = 3 + 2A(3, k)$  (by part (c)) =  $3 + 2(2^{k+3} - 3)$  (by the induction hypothesis) =  $2^{(k+1)+3} - 3$ , so the result holds for  $n = k + 1$  whenever it does for  $n = k$ . Therefore,  $A(3, n) = 2^{n+3} - 3$ , for all  $n \in \mathbf{N}$  — by the Principle of Mathematical Induction.

28. (a)  $\binom{5}{4}4^4 + \binom{5}{3}4^3 + \binom{5}{2}4^2 + \binom{5}{1}4^1 = (4 + 1)^5 - \binom{5}{5}4^5 - \binom{5}{0}4^0 = 5^5 - 4^5 - 1$

(b)  $\binom{m}{m-1}n^{m-1} + \binom{m}{m-2}n^{m-2} + \dots + \binom{m}{1}n^1 = (n + 1)^m - n^m - 1$ .

### Section 5.3

- Let  $A = \{1, 2, 3, 4\}$ ,  $B = \{v, w, x, y, z\}$ :
  - $f = \{(1, v), (2, v), (3, w), (4, x)\}$
  - $f = \{(1, v), (2, x), (3, y), (4, z)\}$
  - Let  $A = \{1, 2, 3, 4, 5\}$ ,  $B = \{w, x, y, z\}$ ,  $f = \{(1, w), (2, w), (3, x), (4, y), (5, z)\}$ .
  - Let  $A = \{1, 2, 3, 4\}$ ,  $B = \{w, x, y, z\}$ ,  $f = \{(1, w), (2, x), (3, y), (4, z)\}$ .

- One-to-one and onto.
  - One-to-one but not onto. The range consists of all the odd integers.
  - One-to-one and onto.
  - Since  $f(-1) = f(1)$ ,  $f$  is not one-to-one. Also  $f$  is not onto. The range of  $f = \{0, 1, 4, 9, 16, \dots\}$ .
  - Since  $f(0) = f(-1)$ ,  $f$  is not one-to-one. Also  $f$  is not onto. The range of  $f = \{0, 2, 6, 12, 20, \dots\}$ .
  - One-to-one but not onto. The range of  $f = \{\dots, -64, -27, -8, -1, 0, 1, 8, 27, \dots\}$ .

- (a), (b), (c), (f) One-to-one and onto.
  - Neither one-to-one nor onto. Range =  $[0, +\infty)$
  - Neither one-to-one nor onto. Range =  $[-1/4, +\infty)$

4. (a)  $6^4$ ;  $6!/2!$ ; 0 (b)  $4^6$ ;  $(4!)S(6,4)$ ; 0

5. For  $n = 5, m = 3, \sum_{k=0}^5 (-1)^k \binom{5}{5-k} (5-k)^3 = (-1)^0 \binom{5}{5} (5)^3 + (-1)^1 \binom{5}{4} (4)^3 + (-1)^2 \binom{5}{3} (3)^3 + (-1)^3 \binom{5}{2} (2)^3 + (-1)^4 \binom{5}{1} (1)^3 + (-1)^5 \binom{5}{0} (0)^3 = 125 - 320 + 70 - 80 + 5 = 0$

6. (a)  $\sum_{i=1}^5 \binom{5}{i} (i!) S(7, i) = \binom{5}{1} (1!) S(7, 1) + \binom{5}{2} (2!) S(7, 2) + \binom{5}{3} (3!) S(7, 3) + \binom{5}{4} (4!) S(7, 4) + \binom{5}{5} (5!) S(7, 5) = (5)(1)(1) + (10)(2)(63) + (10)(6)(301) + (5)(24)(350) + (1)(120)(14) = 78,125 = 5^7.$

(b) The expression  $m^n$  counts the number of ways to distribute  $n$  distinct objects among  $m$  distinct containers.

For  $1 \leq i \leq m$ , let  $i$  count the number of distinct containers that we actually use — that is, those that are *not* empty after the  $n$  distinct objects are distributed. This number of distinct containers can be chosen in  $\binom{m}{i}$  ways. Once we have the  $i$  distinct containers we can distribute the  $n$  distinct objects among these  $i$  distinct containers, with no container left empty, in  $(i!) S(n, i)$  ways — where  $S(n, i) = 0$  when  $n < i$ . Then  $\sum_{i=1}^m \binom{m}{i} (i!) S(n, i)$  also counts the number of ways to distribute  $n$  distinct objects among  $m$  distinct containers.

Hence  $m^n = \sum_{i=1}^m \binom{m}{i} (i!) S(n, i).$

7. (a) (i)  $2! S(7, 2)$  (ii)  $\binom{5}{2} [2! S(7, 2)]$  (iii)  $3! S(7, 3)$   
 (iv)  $\binom{5}{3} [3! S(7, 3)]$  (v)  $4! S(7, 4)$  (vi)  $\binom{5}{4} [4! S(7, 4)]$

(b)  $\binom{n}{k} [k! S(m, k)]$

8. Let  $A$  be the set of compounds and  $B$  the set of assistants. Then the number of assignments with no idle assistants is the number of onto functions from set  $A$  to set  $B$ . There are  $5! S(9, 5)$  such functions.

9. For each  $r \in \mathbf{R}$  there is at least one  $a \in \mathbf{R}$  such that  $a^5 - 2a^2 + a - r = 0$  because the polynomial  $x^5 - 2x^2 + x - r$  has odd degree and real coefficients. Consequently,  $f$  is onto. However,  $f(0) = 0 = f(1)$ , so  $f$  is not one-to-one.

10. (a)  $(4!) S(7, 4)$   
 (b)  $(3!) S(6, 3)$  (Here container II contains only the blue ball) +  $(4!) S(6, 4)$  (Here container II contains more than just the blue ball).  
 (c)  $S(7, 4) + S(7, 3) + S(7, 2) + S(7, 1).$

11.

$n$	1	2	3	4	5	6	7	8	9	10
$m$										
9	1	255	3025	7770	6951	2646	462	36	1	
10	1	511	9330	34105	42525	22827	5880	750	45	1

12. (a) Since  $31,100,905 = 5 \times 11 \times 17 \times 29 \times 31 \times 37$ , we find that there are  $S(6, 3) = 90$  unordered factorizations of 31,100,905 into three factors — each greater than 1.

(b) If the order of the factors in part (a) is considered relevant then there are  $(3!)S(6, 3) = 540$  such factorizations.

$$(c) \sum_{i=2}^6 S(6, i) = S(6, 2) + S(6, 3) + S(6, 4) + S(6, 5) + S(6, 6) = 31 + 90 + 65 + 15 + 1 = 202$$

$$(d) \sum_{i=2}^6 (i!)S(6, i) = (2!)S(6, 2) + (3!)S(6, 3) + (4!)S(6, 4) + (5!)S(6, 5) + (6!)S(6, 6) =$$

$$(2)(31) + (6)(90) + (24)(65) + (120)(15) + (720)(1) = 4682.$$

13. (a) Since  $156,009 = 3 \times 7 \times 17 \times 19 \times 23$ , it follows that there are  $S(5, 2) = 15$  two-factor unordered factorizations of 156,009, where each factor is greater than 1.

$$(b) \sum_{i=2}^5 S(5, i) = S(5, 2) + S(5, 3) + S(5, 4) + S(5, 5) = 15 + 25 + 10 + 1 = 51.$$

$$(c) \sum_{i=2}^n S(n, i).$$

14.

```

10  Dim S(12, 12)
20  For I = 1 To 12
30      S(I,I) = 1
40  Next I
50  Print "M = : 1"
60  For M = 2 To 12
70      Print "M ="; M; ": 1, ";
80      For N = 2 To M-1
90          S(M,N) = S(M-1,N-1) + N*S(M-1,N)
100         Print S(M,N); ", ";
110     Next N
120     Print " 1"
130 Next M
140 End

```

$$15. a) n = 4: \sum_{i=1}^4 i!S(4, i); \quad n = 5: \sum_{i=1}^5 i!S(5, i)$$

In general, the answer is  $\sum_{i=1}^n i!S(n, i)$ .

b)  $\binom{15}{12} \sum_{i=1}^{12} i!S(12, i)$ .

16. a) (i)  $10!$

(ii) The given outcome — namely,  $\{C_2, C_3, C_7\}$ ,  $\{C_1, C_4, C_9, C_{10}\}$ ,  $\{C_5\}$ ,  $\{C_6, C_8\}$  — is an example of a distribution of ten distinct objects among four distinct containers, with no container left empty. [Or it is an example of an onto function  $f : A \rightarrow B$  where  $A = \{C_1, C_2, \dots, C_{10}\}$  and  $B = \{1, 2, 3, 4\}$ .] There are  $4!S(10, 4)$  such distributions [or functions].

The answer to the question is  $\sum_{i=1}^{10} i!S(10, i)$ .

(iii)  $\binom{10}{3} \sum_{i=1}^7 i!S(7, i)$ .

b)  $\binom{9}{2} \sum_{i=1}^7 i!S(7, i)$

c) For  $0 \leq k \leq 9$ , the number of outcomes where  $C_3$  is tied for first place with  $k$  other candidates is  $\binom{9}{k} \sum_{i=1}^{9-k} i!S(9-k, i)$ . [Part (b) above is the special case where  $k = 3 - 1 = 2$ .]

Summing over the possible values of  $k$  we have the answer  $\sum_{k=0}^9 \binom{9}{k} \sum_{i=1}^{9-k} i!S(9-k, i)$ .

17. Let  $a_1, a_2, \dots, a_m, x$  denote the  $m + 1$  distinct objects. Then  $S_r(m + 1, n)$  counts the number of ways these objects can be distributed among  $n$  identical containers so that each container receives at least  $r$  of the objects.

Each of these distributions falls into exactly one of two categories:

1) The element  $x$  is in a container with  $r$  or more other objects: Here we start with  $S_r(m, n)$  distributions of  $a_1, a_2, \dots, a_m$  into  $n$  identical containers — each container receiving at least  $r$  of the objects. Now we have  $n$  *distinct* containers — distinguished by their contents. Consequently, there are  $n$  choices for locating the object  $x$ . As a result, this category provides  $nS_r(m, n)$  of the distributions.

2) The element  $x$  is in a container with  $r - 1$  of the other objects: These other  $r - 1$  objects can be chosen in  $\binom{m}{r-1}$  ways, and then these objects — along with  $x$  — can be placed in one of the  $n$  containers. The remaining  $m + 1 - r$  distinct objects can then be distributed among the  $n - 1$  identical containers — where each container receives at least  $r$  of the objects — in  $S_r(m + 1 - r, n - 1)$  ways. Hence this category provides the remaining  $\binom{m}{r-1} S_r(m + 1 - r, n - 1)$  distributions.

18. (a) For  $n > m$  we have  $s(m, n) = 0$ , because there are more tables than people.

(b) For  $m \geq 1$ , (i)  $s(m, m) = 1$  because the ordering of the  $m$  tables is not taken into account; and, (ii)  $s(m, 1) = (m - 1)!$ , as in Example 1.16.

(c) Here there are two people at one table and one at each of the other  $m - 1$  tables. There are  $\binom{m}{2}$  such arrangements.

(d) When  $m$  people are seated around  $m - 2$  tables there are two cases to consider: (1) One table with three occupants and  $m - 3$  tables, each with one occupant — there are  $\binom{m}{3}(2!)$  such arrangements; and, (2) Two tables, each with two occupants, and  $m - 4$  tables each with a single occupant — there are  $(1/2)\binom{m}{2}\binom{m-2}{2}$  of these arrangements. We then find that  $\binom{m}{3}(2!) + (1/2)\binom{m}{2}\binom{m-2}{2} = (1/3)(m)(m-1)(m-2) + (1/2)[(1/2)(m)(m-1)][(1/2)(m-2)(m-3)] = (m)(m-1)(m-2)[(1/3) + (1/8)(m-3)] = (1/24)(m)(m-1)(m-2)(3m-1)$ .

19. (a) We know that  $s(m, n)$  counts the number of ways we can place  $m$  people — call them  $p_1, p_2, \dots, p_m$  — around  $n$  circular tables, with at least one occupant at each table. These arrangements fall into two disjoint sets: (1) The arrangements where  $p_1$  is alone: There are  $s(m - 1, n - 1)$  such arrangements; and, (2) The arrangements where  $p_1$  shares a table with at least one of the other  $m - 1$  people: There are  $s(m - 1, n)$  ways where  $p_2, p_3, \dots, p_m$  can be seated around the  $n$  tables so that every table is occupied. Each such arrangement determines a total of  $m - 1$  locations (at all the  $n$  tables) where  $p_1$  can now be seated — this for a total of  $(m - 1)s(m - 1, n)$  arrangements. Consequently,  $s(m, n) = (m - 1)s(m - 1, n) + s(m - 1, n - 1)$ , for  $m \geq n > 1$ .

(b) For  $m = 2$ , we have  $s(2, 2) = 1 = 1!(1/1) = (m - 1)! \sum_{i=1}^{m-1} \frac{1}{i}$ . So the result is true in this case; this establishes the basis step for a proof by mathematical induction. Assuming the result for  $m = k (\geq 2)$  we have  $s(k, 2) = (k - 1)! \sum_{i=1}^{k-1} \frac{1}{i}$ . Using the result from part (a) we now find that  $s(k + 1, 2) = ks(k, 2) + s(k, 1) = k(k - 1)! \sum_{i=1}^{k-1} \frac{1}{i} + (k - 1)! = k! \sum_{i=1}^{k-1} \frac{1}{i} + (1/k)k! = k! \sum_{i=1}^k \frac{1}{i}$ . The result now follows for all  $m \geq 2$  by the Principle of Mathematical Induction.

## Section 5.4

- Here we find, for example, that  $f(f(a, b), c) = f(a, c) = c$ , while  $f(a, f(b, c)) = f(a, b) = a$ , so  $f$  is *not* associative.
- (a) For all  $a, b \in \mathbf{R}$ ,  $f(a, b) = \lceil a + b \rceil = \lceil b + a \rceil = f(b, a)$ , because the real numbers are commutative under addition. Hence  $f$  is a commutative (closed) binary operation.  
 (b) This binary operation is *not* associative. For example,

$$f(f(3.2, 4.7), 6.4) = f(\lceil 3.2 + 4.7 \rceil, 6.4) = f(\lceil 7.9 \rceil, 6.4) = f(8, 6.4) = \lceil 8 + 6.4 \rceil = \lceil 14.4 \rceil = 15,$$



12. (a)  $\pi_A(D) = [0, +\infty)$   $\pi_B(D) = \mathbf{R}$   
 (b)  $\pi_A(D) = \mathbf{R}$   $\pi_B(D) = [-1, 1]$   
 (c)  $\pi_A(D) = [-1, 1]$   $\pi_B(D) = [-1, 1]$
13. (a) 5 (b)  $\{(25, 25, 6), (25, 2, 4), (60, 40, 20), (25, 40, 10)\}$   
 (c)  $A_1, A_2$
14. (a) 5  
 (b)  $\{(1, A), (1, D), (1, E), (2, A), (2, D), (2, E)\};$   
 $\{(10000, 1, 100), (400, 1, 100), (30, 1, 100), (4000, 1, 250), (400, 1, 250), (15, 1, 250)\}$   
 (c)  $A_1 \times A_2; A_2 \times A_5; A_3 \times A_5$

### Section 5.5

- Here the socks are the pigeons and the colors are the pigeonholes.
- The result follows by the Pigeonhole Principle where the eight people are the pigeons and the pigeonholes are the seven days of the week.
- $26^2 + 1 = 677$
- Subdivide the set  $S$  into the 14 subsets:  $\{3\}, \{7, 103\}, \{11, 99\}, \{15, 95\}, \dots, \{43, 67\}, \{47, 63\}, \{51, 59\}, \{55\}$ . By the Pigeonhole Principle if we select at least 15 elements of  $S$  then we must have the elements in one of the two-element subsets and these sum to 110.
- (a) For each  $x \in \{1, 2, 3, \dots, 300\}$  wrote  $x = 2^n \cdot m$ , where  $n \geq 0$  and  $\gcd(2, m) = 1$ . There are 150 possibilities for  $m$ : namely,  $1, 3, 5, \dots, 299$ . In selecting 151 numbers from  $\{1, 2, 3, \dots, 300\}$  there must be two numbers of the form  $x = 2^s \cdot m$ ,  $y = 2^t \cdot m$ . If  $x < y$  then  $x|y$ ; otherwise  $y < x$  and  $y|x$ .  
 (b) If  $n + 1$  integers are selected from the set  $\{1, 2, 3, \dots, 2n\}$ , then there must be two integers  $x, y$  in the selection where  $x|y$  or  $y|x$ .
- Any selection of size 101 from  $S$  must contain two consecutive integers  $n, n + 1$  and  $\gcd(n, n + 1) = 1$ .
- (a) Here the pigeons are the integers  $1, 2, 3, \dots, 25$  and the pigeonholes are the 13 sets:  $\{1, 25\}, \{2, 24\}, \dots, \{11, 15\}, \{12, 14\}, \{13\}$ . In selecting 14 integers we get the elements in at least one two-element subset, and these sum to 26.  
 (b) If  $S = \{1, 2, 3, \dots, 2n + 1\}$ , for  $n$  a positive integer, then any subset of size  $n + 2$  from  $S$  must contain two elements that sum to  $2n + 2$ .
- (a) Since  $|S| \geq 3$ ,  $\exists x, y \in S$  where  $x, y$  are both even or both odd. In either case  $x + y$  is even.  
 (b)  $5 (= 2^2 + 1)$  (c)  $9 (= 2^3 + 1)$

- (d) For  $n \in \mathbf{Z}^+$  let  $S = \{(a_1, a_2, \dots, a_n) \mid a_i \in \mathbf{Z}^+, 1 \leq i \leq n\}$ . If  $|S| \geq 2^n + 1$ , then  $S$  contains two ordered  $n$ -tuples  $(x_1, x_2, \dots, x_n), (y_1, y_2, \dots, y_n)$  such that  $x_i + y_i$  is even  $\forall 1 \leq i \leq n$ .
- (e) 5 - as in part (b).
9. (a) For any  $t \in \{1, 2, 3, \dots, 100\}, 1 \leq \sqrt{t} \leq 10$ . Selecting 11 elements from  $\{1, 2, 3, \dots, 100\}$  there must be two, say  $x$  and  $y$ , where  $\lfloor \sqrt{x} \rfloor = \lfloor \sqrt{y} \rfloor$ , so that  $0 < |\sqrt{x} - \sqrt{y}| < 1$ .
- (b) Let  $n \in \mathbf{Z}^+$ . If  $n + 1$  elements are selected from  $\{1, 2, 3, \dots, n^2\}$ , then there exist two, say  $x$  and  $y$ , where  $0 < |\sqrt{x} - \sqrt{y}| < 1$ .

10.

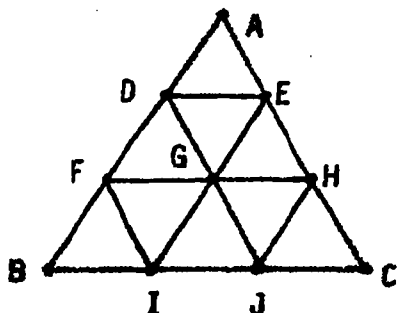

In triangle  $ABC$ , divide each side into three equal parts and form the nine congruent triangles shown in the figure. Let  $R_1$  be the interior of triangle  $ADE$  together with the points on segment  $DE$ , excluding  $D, E$ . Region  $R_2$  is the interior of triangle  $DFG$  together with the points on segments  $DG, FG$ , excluding  $D, F$ . Regions  $R_3, \dots, R_9$  are defined similarly so that the interior of  $\triangle ABC$  is the union of these nine regions and  $R_i \cap R_j = \emptyset$ , for  $i \neq j$ . Then if 10 points are chosen in the interior of  $\triangle ABC$ , at least two of these points are in  $R_i$  for some  $1 \leq i \leq 9$ , and these two points are at a distance less than  $1/3$  from each other.

11.

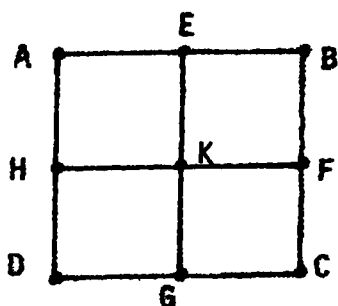

Divide the interior of the square into four smaller congruent squares as shown in the figure. Each smaller square has diagonal length  $1/\sqrt{2}$ . Let region  $R_1$  be the interior of square  $AEKH$  together with the points on segment  $EK$ , excluding point  $E$ . Region  $R_2$  is the interior of square  $EBFK$  together with the points on segment  $FK$ , excluding points  $F, K$ . Regions  $R_3, R_4$  are defined in a similar way. Then if five points are chosen in the interior of square  $ABCD$ , at least two are in  $R_i$  for some  $1 \leq i \leq 4$  and these points are within  $1/\sqrt{2}$  (units) of each other.

12. For any five-element subset  $E$  of  $A$  we find that  $1 + 2 + 3 + 4 + 5 = 15 \leq s_E \leq 115 \leq 21 + 22 + 23 + 24 + 25$ , so there are 116 possible values for such a sum  $s_E$ . Since  $|A| = 9$ , there are  $\binom{9}{5} = 126$  five-element subsets of  $A$ .

The result now follows by the Pigeonhole Principle where the 126 five-element subsets of  $A$  are the pigeons and the 116 possible sums are the pigeonholes.

13. Consider the subsets  $A$  of  $S$  where  $1 \leq |A| \leq 3$ . Since  $|S| = 5$ , there are  $\binom{5}{1} + \binom{5}{2} + \binom{5}{3} = 25$  such subsets  $A$ . Let  $s_A$  denote the sum of the elements in  $A$ . Then  $1 \leq s_A \leq 7 + 8 + 9 = 24$ . So by the Pigeonhole Principle, there are two subsets of  $S$  whose elements yield the same sum.
14. For  $1 \leq i \leq 42$ , let  $x_i$  count the total number of resumés Brace has sent out from the start of his senior year to the end of the  $i$ -th day. Then  $1 \leq x_1 < x_2 < \dots < x_{42} \leq 60$ , and  $x_1 + 23 < x_2 + 23 < \dots < x_{42} + 23 \leq 83$ . We have 42 distinct numbers  $x_1, x_2, \dots, x_{42}$ , and 42 other distinct numbers  $x_1 + 23, x_2 + 23, \dots, x_{42} + 23$ , all between 1 and 83 inclusive. By the Pigeonhole Principle  $x_i = x_j + 23$  for some  $1 \leq j < i \leq 42$ ;  $x_i - x_j = 23$ .
15. For  $(\emptyset \neq) T \subseteq S$ , we have  $1 \leq s_T \leq m + (m - 1) + \dots + (m - 6) = 7m - 21$ . The set  $S$  has  $2^7 - 1 = 128 - 1 = 127$  nonempty subsets. So by the Pigeonhole Principle we need to have  $127 > 7m - 21$  or  $148 > 7m$ . Hence  $7 \leq m \leq 21$ .

16. Proof: Consider the  $k + 1$  integers: (1) 3; (2) 33; (3) 333; ...; and  $(k + 1)$  333...3, where for all  $1 \leq i \leq k + 1$ , the  $i$ -th integer has  $i$  digits – each of which is a 3. Since there are  $k + 1$  integers, it follows from the Division Algorithm and the Pigeonhole Principle that two of these integers, say  $a$  and  $b$ , have the same remainder when divided by  $k$ . Suppose that  $a = q_1k + r$ ,  $b = q_2k + r$ , and that  $a > b$ . Then  $a - b = (q_1 - q_2)k$ , so  $k|(a - b)$  and the only digits in  $a - b$  are 0's and 3's. [Note: The integer 3 is not special. The result is also true if we replace 3 by any of the digits 1, 2, 4, 5, 6, 7, 8, 9. However, we cannot obtain the result without using the digit 0.]
17. (a) 2,4,1,3  
 (b) 3,6,9,2,5,8,1,4,7  
 (c) For  $n \geq 2$ , there exists a sequence of  $n^2$  distinct real numbers with no decreasing or increasing subsequence of length  $n + 1$ . For example, consider  $n, 2n, 3n, \dots, (n-1)n, n^2, (n-1), (2n-1), \dots, (n^2-1), (n-2), (2n-2), \dots, (n^2-2), \dots, 1, (n+1), (2n+1), \dots, (n-1)n+1$ .  
 (d) The result in Example 5.49 (for  $n \geq 2$ ) is best possible – in the sense that we cannot reduce the length of the sequence from  $n^2 + 1$  to  $n^2$  and still obtain the desired subsequence of length  $n + 1$ .
18. This follows from the result due to Paul Erdős and George Szekeres: A sequence of  $50(= 7^2 + 1)$  distinct real numbers contains a decreasing or increasing subsequence of length  $8(= 7 + 1)$ .
19. Proof: If not each pigeonhole contains at most  $k$  pigeons – for a total of at most  $kn$  pigeons. But we have  $kn + 1$  pigeons. So we have a contradiction and the result then follows.
20. (a) 7 (b) 13 (c)  $6(n - 1) + 1$
21. (a) 1001 (b) 2001  
 (c) Let  $k, n \in \mathbf{Z}^+$ . The smallest value for  $|S|$  (where  $S \subset \mathbf{Z}^+$ ) so that there exist  $n$  elements  $x_1, x_2, \dots, x_n \in S$  where all  $n$  of these integers have the same remainder upon division by  $k$  is  $k(n - 1) + 1$ .
22. Proof: If not, each pigeonhole contains at most  $\lfloor (m - 1)/n \rfloor$  pigeons – for a total of  $n\lfloor (m - 1)/n \rfloor \leq m - 1$  pigeons. But this contradicts the fact that we have  $m$  pigeons. The result then follows.  
 [Note: This result is true even if  $m \leq n$ .]
23. Proof: If not, then the number of pigeons roosting in the first pigeonhole is  $x_1 \leq p_1 - 1$ , the number of pigeons roosting in the second pigeonhole is  $x_2 \leq p_2 - 1, \dots$ , and the number roosting in the  $n$ -th pigeonhole is  $x_n \leq p_n - 1$ . Hence the total number of pigeons is  $x_1 + x_2 + \dots + x_n = (p_1 - 1) + (p_2 - 1) + \dots + (p_n - 1) = p_1 + p_2 + \dots + p_n - n < p_1 + p_2 + \dots + p_n - n + 1$ , the number of pigeons we started with. The result now follows because of this contradiction.

## Section 5.6

1. (a) There are  $7!$  bijective functions on  $A$  - of these,  $6!$  satisfy  $f(1) = 1$ . Hence there are  $7! - 6! = 6(6!)$  bijective functions  $f : A \rightarrow A$  where  $f(1) \neq 1$ .  
 (b)  $n! - (n-1)! = (n-1)(n-1)!$

2. (a) Here  $f, g$  have the same domain  $A$  and some codomain  $\mathbf{R}$ , and for all  $x \in A$  we find that

$$g(x) = \frac{2x^2 - 8}{x + 2} = \frac{2(x^2 - 4)}{x + 2} = \frac{2(x-2)(x+2)}{(x+2)} = 2(x-2) = 2x - 4 = f(x).$$

Consequently,  $f = g$ .

(b) Here there is a problem and  $f \neq g$ . In fact for any nonempty subset  $A$  of  $\mathbf{R}$ , if  $-2 \in A$  then  $g$  is not defined for  $A$  because  $g(-2) = 0/0$ . [We note that  $\frac{x^2-4}{x+2} = x-2$ , for  $x \neq -2$ .]

3.  $9x^2 - 9x + 3 = g(f(x)) = 1 - (ax + b) + (ax + b)^2 = a^2x^2 + (2ab - a)x + (b^2 - b + 1)$ . By comparing coefficients on like powers of  $x$ ,  $a = 3, b = -1$  or  $a = -3, b = 2$ .

4.  $g \circ f = \{(1, 4), (2, 6), (3, 10), (4, 14)\}$

5.  $g^2(A) = g(T \cap (S \cup A)) = T \cap (S \cup [T \cap (S \cup A)]) = T \cap [(S \cup T) \cap (S \cup (S \cup A))] = T \cap [(S \cup T) \cap (S \cup A)] = [T \cap (S \cup T)] \cap (S \cup A) = T \cap (S \cup A) = g(A)$ .

6.  $(f \circ g)(x) = f(cx + d) = a(cx + d) + b$   
 $(g \circ f)(x) = g(ax + b) = c(ax + b) + d$   
 $(f \circ g)(x) = (g \circ f)(x) \iff acx + ad + b = acx + bc + d \iff ad + b = bc + d$

7. (a)  $(f \circ g)(x) = 3x - 1$ ;  $(g \circ f)(x) = 3(x - 1)$ ;

$$(g \circ h)(x) = \begin{cases} 0, & x \text{ even;} \\ 3, & x \text{ odd} \end{cases} \quad (h \circ g)(x) = \begin{cases} 0, & x \text{ even;} \\ 1, & x \text{ odd} \end{cases}$$

$$(f \circ (g \circ h))(x) = f((g \circ h)(x)) = \begin{cases} -1, & x \text{ even;} \\ 2, & x \text{ odd} \end{cases}$$

$$((f \circ g) \circ h)(x) = \begin{cases} (f \circ g)(0), & x \text{ even} \\ (f \circ g)(1), & x \text{ odd} \end{cases} = \begin{cases} -1, & x \text{ even} \\ 2, & x \text{ odd} \end{cases}$$

(b)  $f^2(x) = f(f(x)) = x - 2$ ;  $f^3(x) = x - 3$ ;  $g^2(x) = 9x$ ;  $g^3(x) = 27x$ ;  $h^2 = h^3 = h^{500} = h$ .

8. (a) If  $c \in C$ , there is an element  $a \in A$  such that  $(g \circ f)(a) = c$ . Then  $g(f(a)) = c$  with  $f(a) \in B$ , so  $g$  is onto.

(b) Let  $x, y \in A$ .  $f(x) = f(y) \implies g(f(x)) = g(f(y)) \implies (g \circ f)(x) = (g \circ f)(y) \implies x = y$ , since  $g \circ f$  is one-to-one.

9. (a)  $f^{-1}(x) = \frac{1}{2}(\ln x - 5)$

(b) For  $x \in \mathbf{R}^+$ ,  $(f \circ f^{-1})(x) = f(\frac{1}{2}(\ln x - 5)) = e^{2((1/2)(\ln x - 5)) + 5} = e^{\ln x - 5 + 5} = e^{\ln x} = x$ ;  
for  $x \in \mathbf{R}$ ,  $(f^{-1} \circ f)(x) = f^{-1}(e^{2x+5}) = \frac{1}{2}[\ln(e^{2x+5}) - 5] = \frac{1}{2}[2x + 5 - 5] = x$ .

10. (a)  $f^{-1} = \{(x, y) | 2y + 3x = 7\}$  (b)  $f^{-1} = \{(x, y) | ay + bx = c, b \neq 0, a \neq 0\}$

(c)  $f^{-1} = \{(x, y) | y = x^{1/3}\} = \{(x, y) | x = y^3\}$

(d) Here  $f(0) = f(-1) = 0$ , so  $f$  is not one-to-one, and consequently  $f$  is not invertible.

11.  $f, g$  invertible  $\implies$  each of  $f, g$  is both one-to-one and onto  $\implies g \circ f$  is one-to-one and onto  $\implies g \circ f$  invertible. Since  $(g \circ f) \circ (f^{-1} \circ g^{-1}) = 1_C$  and  $(f^{-1} \circ g^{-1}) \circ (g \circ f) = 1_A$ ,  $f^{-1} \circ g^{-1}$  is an inverse of  $g \circ f$ . By uniqueness of inverses  $f^{-1} \circ g^{-1} = (g \circ f)^{-1}$ .

12. (a)  $f^{-1}(\{2\}) = \{a \in A | f(a) \in \{2\}\} = \{a \in A | f(a) = 2\} = \{1\}$

(b)  $f^{-1}(\{6\}) = \{a \in A | f(a) \in \{6\}\} = \{a \in A | f(a) = 6\} = \{2, 3, 5\}$

(c)  $f^{-1}(\{6, 8\}) = \{a \in A | f(a) \in \{6, 8\}\} = \{a \in A | f(a) = 6 \text{ or } f(a) = 8\} = \{2, 3, 4, 5, 6\}$ ,  
because  $f(2) = f(3) = f(5) = 6$  and  $f(4) = f(6) = 8$ .

(d)  $f^{-1}(\{6, 8, 10\}) = \{2, 3, 4, 5, 6\} = f^{-1}(\{6, 8\})$  since  $f^{-1}(\{10\}) = \emptyset$ .

(e)  $f^{-1}(\{6, 8, 10, 12\}) = \{2, 3, 4, 5, 6, 7\}$

(f)  $f^{-1}(\{10, 12\}) = \{7\}$

13.

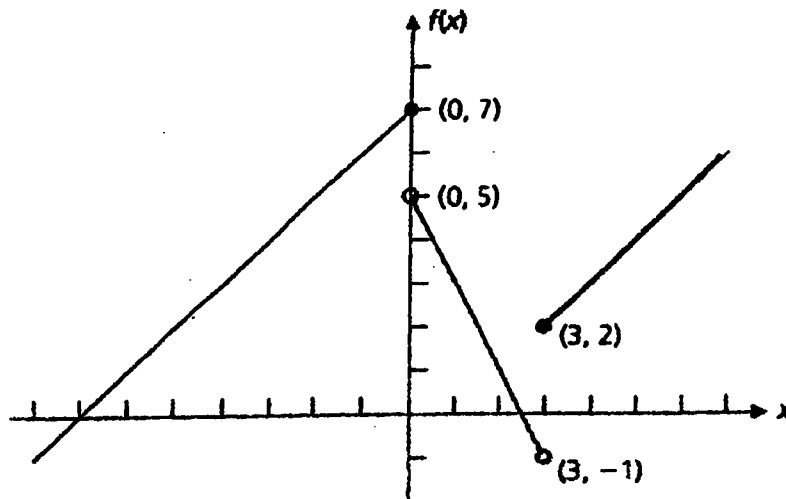

(a)  $f^{-1}(-10) = \{x \in \mathbf{R} | x \leq 10 \text{ and } x + 7 = -10\} = \{-17\}$

$f^{-1}(0) = \{-7, 5/2\}$

$f^{-1}(4) = \{-3, 1/2, 5\}$

$f^{-1}(6) = \{-1, 7\}$

$f^{-1}(7) = \{0, 8\}$

$f^{-1}(8) = \{9\}$

(b) (i)  $f^{-1}([-5, -1]) = \{x \in \mathbf{R} \mid x \leq 0 \text{ and } -5 \leq x + 7 \leq -1\} \cup \{x \in \mathbf{R} \mid 0 < x < 3 \text{ and } -5 \leq -2x + 5 \leq -1\} \cup \{x \in \mathbf{R} \mid 3 \leq x \text{ and } -5 \leq x - 1 \leq -1\} = \{x \in \mathbf{R} \mid x \leq 0 \text{ and } -12 \leq x \leq -8\} \cup \{x \in \mathbf{R} \mid 0 < x < 3 \text{ and } 3 \leq x \leq 5\} \cup \{x \in \mathbf{R} \mid 3 \leq x \text{ and } -4 \leq x \leq 0\} = [-12, -8] \cup \emptyset \cup \emptyset = [-12, -8]$

(ii)  $f^{-1}([-5, 0]) = [-12, -7] \cup [5/2, 3]$

(iii)  $f^{-1}([-2, 4]) = \{x \in \mathbf{R} \mid x \leq 0 \text{ and } -2 \leq x + 7 \leq 4\} \cup \{x \in \mathbf{R} \mid 0 < x < 3 \text{ and } -2 \leq -2x + 5 \leq 4\} \cup \{x \in \mathbf{R} \mid 3 \leq x \text{ and } -2 \leq x - 1 \leq 4\} = \{x \in \mathbf{R} \mid x \leq 0 \text{ and } -9 \leq x \leq -3\} \cup \{x \in \mathbf{R} \mid 0 < x < 3 \text{ and } 1/2 \leq x \leq 7/2\} \cup \{x \in \mathbf{R} \mid 3 \leq x \text{ and } -1 \leq x \leq 5\} = [-9, -3] \cup [1/2, 3] \cup [3, 5] = [-9, -3] \cup [1/2, 5]$

(iv)  $f^{-1}((5, 10)) = (-2, 0] \cup (6, 11)$

(v)  $f^{-1}([11, 17]) = \{x \in \mathbf{R} \mid x \leq 0 \text{ and } 11 \leq x + 7 < 17\} \cup \{x \in \mathbf{R} \mid 0 < x < 3 \text{ and } 11 \leq -2x + 5 < 17\} \cup \{x \in \mathbf{R} \mid 3 \leq x \text{ and } 11 \leq x - 1 < 17\} = \{x \in \mathbf{R} \mid x \leq 0 \text{ and } 4 \leq x < 10\} \cup \{x \in \mathbf{R} \mid 0 < x < 3 \text{ and } -6 < x \leq -3\} \cup \{x \in \mathbf{R} \mid 3 \leq x \text{ and } 12 \leq x < 18\} = \emptyset \cup \emptyset \cup [12, 18) = [12, 18)$

14. (a)  $\{-1, 0, 1\}$       (b)  $\{-1, 0, 1\}$       (c)  $[-1, 1]$       (d)  $(-1, 1)$   
 (e)  $[-2, 2]$       (f)  $(-3, -2) \cup [-1, 0) \cup (0, 1] \cup (2, 3)$

15. Since  $f^{-1}(\{6, 7, 8\}) = \{1, 2\}$  there are three choices for each of  $f(1)$  and  $f(2)$  – namely, 6, 7 or 8. Furthermore  $3, 4, 5 \notin f^{-1}(\{6, 7, 8\})$  so  $3, 4, 5 \in f^{-1}(\{9, 10, 11, 12\})$  and we have four choices for each of  $f(3)$ ,  $f(4)$ , and  $f(5)$ . Therefore, it follows by the rule of product that there are  $3^2 \cdot 4^3 = 576$  functions  $f : A \rightarrow B$  where  $f^{-1}(\{6, 7, 8\}) = \{1, 2\}$ .

16. (a)  $[0, 2)$       (b)  $[-1, 2)$       (c)  $[0, 1)$       (d)  $[0, 2)$   
 (e)  $[-1, 3)$       (f)  $[-1, 0) \cup [2, 4)$

17. (a) The range of  $f = \{2, 3, 4, \dots\} = \mathbf{Z}^+ - \{1\}$ .  
 (b) Since 1 is not in the range of  $f$  the function is not onto.  
 (c) For all  $x, y \in \mathbf{Z}^+$ ,  $f(x) = f(y) \Rightarrow x + 1 = y + 1 \Rightarrow x = y$ , so  $f$  is one-to-one.  
 (d) The range of  $g$  is  $\mathbf{Z}^+$ .  
 (e) Since  $g(\mathbf{Z}^+) = \mathbf{Z}^+$ , the codomain of  $g$ , this function is onto.  
 (f) Here  $g(1) = 1 = g(2)$ , and  $1 \neq 2$ , so  $g$  is not one-to-one.  
 (g) For all  $x \in \mathbf{Z}^+$ ,  $(g \circ f)(x) = g(f(x)) = g(x + 1) = \max\{1, (x + 1) - 1\} = \max\{1, x\} = x$ , since  $x \in \mathbf{Z}^+$ . Hence  $g \circ f = 1_{\mathbf{Z}^+}$ .  
 (h)  $(f \circ g)(2) = f(\max\{1, 1\}) = f(1) = 1 + 1 = 2$   
 $(f \circ g)(3) = f(\max\{1, 2\}) = f(2) = 2 + 1 = 3$   
 $(f \circ g)(4) = f(\max\{1, 3\}) = f(3) = 3 + 1 = 4$   
 $(f \circ g)(7) = f(\max\{1, 6\}) = f(6) = 6 + 1 = 7$   
 $(f \circ g)(12) = f(\max\{1, 11\}) = f(11) = 11 + 1 = 12$   
 $(f \circ g)(25) = f(\max\{1, 24\}) = f(24) = 24 + 1 = 25$   
 (i) No, because the functions  $f, g$  are *not* inverses of each other. The calculations in part (h) may suggest that  $f \circ g = 1_{\mathbf{Z}^+}$  since  $(f \circ g)(x) = x$  for  $x \geq 2$ . But we also find that  $(f \circ g)(1) = f(\max\{1, 0\}) = f(1) = 2$ , so  $(f \circ g)(1) \neq 1$ , and, consequently,  $f \circ g \neq 1_{\mathbf{Z}^+}$ .

18. (a)  $f(\emptyset, \emptyset) = \emptyset = f(\emptyset, \{1\})$  and  $(\emptyset, \emptyset) \neq (\emptyset, \{1\})$ , so  $f$  is not one-to-one.  
 $g(\{1\}, \{2\}) = \{1, 2\} = g(\{1, 2\}, \{2\})$  and  $(\{1\}, \{2\}) \neq (\{1, 2\}, \{2\})$ , so  $g$  is not one-to-one.  
 $h(\{1\}, \{2\}) = \{1, 2\} = h(\{2\}, \{1\})$  and  $(\{1\}, \{2\}) \neq (\{2\}, \{1\})$ , so  $h$  is not one-to-one.
- (b) For each subset  $A$  of  $\mathbf{Z}^+$ ,  $f(A, A) = g(A, A) = h(A, \emptyset) = A$ , so each of the three functions  $f$ ,  $g$ , and  $h$ , is an onto function.
- (c) From the results in part (a) it follows that none of these functions is invertible.
- (d) The sets  $f^{-1}(\emptyset)$ ,  $h^{-1}(\emptyset)$ ,  $f^{-1}(\{1\})$ ,  $h^{-1}(\{3\})$ ,  $f^{-1}(\{4, 7\})$ , and  $h^{-1}(\{5, 9\})$ , are all infinite.
- (e)  $|g^{-1}(\emptyset)| = \{(\emptyset, \emptyset)\}$ , so  $|g^{-1}(\emptyset)| = 1$ .  
 $g^{-1}(\{2\}) = \{(\emptyset, \{2\}), (\{2\}, \emptyset), (\{2\}, \{2\})\}$ , so  $|g^{-1}(\{2\})| = 3$   
 $|g^{-1}(\{8, 12\})| = 9$ .

19. (a)  $a \in f^{-1}(B_1 \cap B_2) \iff f(a) \in B_1 \cap B_2 \iff f(a) \in B_1$  and  $f(a) \in B_2 \iff a \in f^{-1}(B_1)$  and  $a \in f^{-1}(B_2) \iff a \in f^{-1}(B_1) \cap f^{-1}(B_2)$
- (c)  $a \in f^{-1}(\overline{B_1}) \iff f(a) \in \overline{B_1} \iff f(a) \notin B_1 \iff a \notin f^{-1}(B_1) \iff a \in \overline{f^{-1}(B_1)}$

20. (a) (i)  $f(x) = 2x$ ; (ii)  $f(x) = \lfloor x/2 \rfloor$   
(b) No. The set  $\mathbf{Z}$  is not finite.

21. (a) Suppose that  $x_1, x_2 \in \mathbf{Z}$  and  $f(x_1) = f(x_2)$ . Then either  $f(x_1), f(x_2)$  are both even or they are both odd. If they are both even, then  $f(x_1) = f(x_2) \Rightarrow -2x_1 = -2x_2 \Rightarrow x_1 = x_2$ . Otherwise,  $f(x_1), f(x_2)$  are both odd and  $f(x_1) = f(x_2) \Rightarrow 2x_1 - 1 = 2x_2 - 1 \Rightarrow 2x_1 = 2x_2 \Rightarrow x_1 = x_2$ . Consequently, the function  $f$  is one-to-one.

In order to prove that  $f$  is an onto function let  $n \in \mathbf{N}$ . If  $n$  is even, then  $(-n/2) \in \mathbf{Z}$  and  $(-n/2) < 0$ , and  $f(-n/2) = -2(-n/2) = n$ . For the case where  $n$  is odd we find that  $(n+1)/2 \in \mathbf{Z}$  and  $(n+1)/2 > 0$ , and  $f((n+1)/2) = 2\lfloor (n+1)/2 \rfloor - 1 = (n+1) - 1 = n$ . Hence  $f$  is onto.

(b)  $f^{-1} : \mathbf{N} \rightarrow \mathbf{Z}$ , where

$$f^{-1}(x) = \begin{cases} (\frac{1}{2})(x+1), & x = 1, 3, 5, 7, \dots \\ -x/2, & x = 0, 2, 4, 6, \dots \end{cases}$$

22. It follows from Theorem 5.11 that there are  $5!$  invertible functions  $f : A \rightarrow B$ .

23. (a) For all  $n \in \mathbf{N}$ ,  $(g \circ f)(n) = (h \circ f)(n) = (k \circ f)(n) = n$ .
- (b) The results in part (a) do not contradict Theorem 5.7. For although  $g \circ f = h \circ f = k \circ f = 1_{\mathbf{N}}$ , we note that
- (i)  $(f \circ g)(1) = f(\lfloor 1/3 \rfloor) = f(0) = 3 \cdot 0 = 0 \neq 1$ , so  $f \circ g \neq 1_{\mathbf{N}}$ ;
- (ii)  $(f \circ h)(1) = f(\lfloor 2/3 \rfloor) = f(0) = 3 \cdot 0 = 0 \neq 1$ , so  $f \circ h \neq 1_{\mathbf{N}}$ ; and
- (iii)  $(f \circ k)(1) = f(\lfloor 3/3 \rfloor) = f(1) = 3 \cdot 1 = 3 \neq 1$ , so  $f \circ k \neq 1_{\mathbf{N}}$ .
- Consequently, none of  $g, h$ , and  $k$ , is the inverse of  $f$ . (After all, since  $f$  is *not* onto it is *not* invertible.)

## Section 5.7

1. (a)  $f \in O(n)$       (b)  $f \in O(1)$       (c)  $f \in O(n^3)$   
 (d)  $f \in O(n^2)$       (e)  $f \in O(n^3)$       (f)  $f \in O(n^2)$   
 (g)  $f \in O(n^2)$
2. Let  $m = 1$  and  $k = 1$  in Definition 5.23. Then  $\forall n \geq k$   $|f(n)| = n < n + (1/n) = |g(n)|$ , so  $f \in O(g)$ .  
 Now let  $m = 2$  and  $k = 1$ . Then  $\forall n \geq k$   $|g(n)| = n + (1/n) \leq n + n = 2n = 2|f(n)|$ , and  $g \in O(f)$ .
3. (a) For all  $n \in \mathbf{Z}^+$ ,  $0 \leq \log_2 n < n$ . So let  $k = 1$  and  $m = 200$  in Definition 5.23. Then  $|f(n)| = 100 \log_2 n = 100((1/2) \log_2 n) < 200((1/2)n) = 200|g(n)|$ , so  $f \in O(g)$ .  
 (b) For  $n = 6$ ,  $2^n = 64 < 3096 = 4096 - 1000 = 2^{12} - 1000 = 2^{2n} - 1000$ . Assuming that  $2^k < 2^{2k} - 1000$  for  $n = k \geq 6$ , we find that  $2 < 2^2 \implies 2(2^k) < 2^2(2^{2k} - 1000) < 2^{2 \cdot 2^k} - 1000$ , or  $2^{k+1} < 2^{2(k+1)} - 1000$ , so  $f(n) < g(n)$  for all  $n \geq 6$ . Therefore, with  $k = 6$  and  $m = 1$  in Definition 5.23 we find that for  $n \geq k$   $|f(n)| \leq m|g(n)|$  and  $f \in O(g)$ .  
 (c) For all  $n \geq 4$ ,  $n^2 \leq 2^n$  (A formal proof of this can be given by mathematical induction.) So let  $k = 4$  and  $m = 3$  in Definition 5.23. Then for  $n \geq k$ ,  $|f(n)| = 3n^2 \leq 3(2^n) < 3(2^n + 2n) = m|g(n)|$  and  $f \in O(g)$ .
4. Let  $m = 11$  and  $k = 1$ . Then  $\forall n \geq k$   $|f(n)| = n + 100 \leq 11n^2 = m|g(n)|$ , so  $f \in O(g)$ . However,  $\forall m \in \mathbf{R}^+ \forall k \in \mathbf{Z}^+$  choose  $n > \max\{k, 100 + m\}$ . Then  $n^2 > (100 + m)n = 100n + mn > 100m + mn = m(100 + n) = m|f(n)|$ , so  $g \notin O(f)$ .
5. To show that  $f \in O(g)$ , let  $k = 1$  and  $m = 4$  in Definition 5.23. Then for all  $n \geq k$ ,  $|f(n)| = n^2 + n \leq n^2 + n^2 = 2n^2 \leq 2n^3 = 4((1/2)(n^3)) = 4|g(n)|$ , and  $f$  is dominated by  $g$ .  
 To show that  $g \notin O(f)$ , we follow the idea given in Example 5.66 – namely that

$$\forall m \in \mathbf{R}^+ \forall k \in \mathbf{Z}^+ \exists n \in \mathbf{Z}^+ [(n \geq k) \wedge (|g(n)| > m|f(n)|)].$$

So no matter what the values of  $m$  and  $k$  are, choose  $n > \max\{4m, k\}$ . Then  $|g(n)| = (1/2)n^3 > (1/2)(4m)n^2 = m(2n^2) \geq m(n^2 + n) = m|f(n)|$ , so  $g \notin O(f)$ .

6.  $\forall m \in \mathbf{R}^+ \forall k \in \mathbf{Z}^+$  choose  $n > \max\{k, m\}$  with  $n$  odd. Then  $n = |f(n)| > m = m \cdot 1 = m|g(n)|$ , so  $f \notin O(g)$ . In a similar way,  $\forall m \in \mathbf{R}^+ \forall k \in \mathbf{Z}^+$  now choose  $n > \max\{k, m\}$  with  $n$  even. Then  $n = |g(n)| > m = m \cdot 1 = m|f(n)|$ , and  $g \notin O(f)$ .
7. For all  $n \geq 1$ ,  $\log_2 n \leq n$ , so with  $k = 1$  and  $m = 1$  in Definition 5.23 we have  $|g(n)| = \log_2 n \leq n = m \cdot n = m|f(n)|$ . Hence  $g \in O(f)$ .  
 To show that  $f \in O(g)$  we first observe that  $\lim_{n \rightarrow \infty} \frac{n}{\log_2 n} = +\infty$ . (This can be established by using L'Hospital's Rule from the Calculus.) Since  $\lim_{n \rightarrow \infty} \frac{n}{\log_2 n} = +\infty$  we

find that for every  $m \in \mathbf{R}^+$  and  $k \in \mathbf{Z}^+$  there is an  $n \in \mathbf{Z}^+$  such that  $\frac{n}{\log_2 n} > m$ , or  $|f(n)| = n > m \log_2 n = m|g(n)|$ . Hence  $f \notin O(g)$ .

8.  $f \in O(g) \implies \exists m_1 \in \mathbf{R}^+ \exists k_1 \in \mathbf{Z}^+$  so that  $\forall n \geq k_1 |f(n)| \leq m_1|g(n)|$ .  $g \in O(h) \implies \exists m_2 \in \mathbf{R}^+ \exists k_2 \in \mathbf{Z}^+$  so that  $\forall n \geq k_2 |g(n)| \leq m_2|h(n)|$ . Therefore,  $\forall n \geq \max\{k_1, k_2\}$  we have  $|f(n)| \leq m_1|g(n)| \leq m_1 m_2 |h(n)|$  and  $f \in O(h)$ .
9. Since  $f \in O(g)$ , there exists  $m \in \mathbf{R}^+, k \in \mathbf{Z}^+$  so that  $|f(n)| \leq m|g(n)|$  for all  $n \geq k$ . But then  $|f(n)| \leq [m/|c|]|cg(n)|$  for all  $n \geq k$ , so  $f \in O(cg)$ .
10. (a) Let  $k = 1$  and  $m = 1$  in Definition 5.23.  
 (b) If  $h \in O(f)$  and  $f \in O(g)$ , then  $h \in O(g)$  by Exercise 8. Likewise, if  $h \in O(g)$  and  $g \in O(f)$  then  $h \in O(f)$  – again by Exercise 8.  
 (c) This follows from parts (a) and (b).
11. (a) For all  $n \geq 1$ ,  $f(n) = 5n^2 + 3n > n^2 = g(n)$ . So with  $M = 1$  and  $k = 1$ , we have  $|f(n)| \geq M|g(n)|$  for all  $n \geq k$  and it follows that  $f \in \Omega(g)$ .  
 (b) For all  $n \geq 1$ ,  $g(n) = n^2 = (1/10)(5n^2 + 5n^2) > (1/10)(5n^2 + 3n) = (1/10)f(n)$ . So with  $M = (1/10)$  and  $k = 1$ , we find that  $|g(n)| \geq M|f(n)|$  for all  $n \geq k$  and it follows that  $g \in \Omega(f)$ .  
 (c) For all  $n \geq 1$ ,  $f(n) = 5n^2 + 3n > n = h(n)$ . With  $M = 1$  and  $k = 1$ , we have  $|f(n)| \geq M|h(n)|$  for all  $n \geq k$  and so  $f \in \Omega(h)$ .  
 (d) Suppose that  $h \in \Omega(f)$ . If so, there exist  $M \in \mathbf{R}^+$  and  $k \in \mathbf{Z}^+$  with  $|h(n)| \geq M|f(n)| = M(5n^2 + 3n)$  for all  $n \geq k$ . Then  $0 < M \leq n/(5n^2 + 3n) = 1/(5n + 3)$ . But how can  $M$  be a positive constant while  $1/(5n + 3)$  approaches 0 as  $n$  (a variable) gets larger? From this contradiction it follows that  $h \notin \Omega(f)$ .
12. Proof: Suppose that  $f \in \Omega(g)$ . Then there exist  $M \in \mathbf{R}^+$  and  $k \in \mathbf{Z}^+$  such that  $|f(n)| > M|g(n)|$  for all  $n \geq k$ . Consequently,  $|g(n)| \leq (1/M)|f(n)|$  for all  $n \geq k$ , so  $g \in O(f)$ .  
 Conversely,  $g \in O(f) \implies \exists m \in \mathbf{R}^+ \exists k \in \mathbf{Z}^+ \forall n \geq k (|g(n)| \leq m|f(n)|) \implies \exists m \in \mathbf{R}^+ \exists k \in \mathbf{Z}^+ \forall n \geq k (|f(n)| \geq (1/m)|g(n)|) \implies \exists M \in \mathbf{R}^+ \exists k \in \mathbf{Z}^+ \forall n \geq k (|f(n)| \geq M|g(n)|) \implies f \in \Omega(g)$ . [Here  $M = 1/m$ .] [Note: Upon replacing each occurrence of  $\implies$  by  $\iff$  we can establish this “if and only if” proof without the first (separate) part in the first paragraph.]
13. (a) For  $n \geq 1$ ,  $f(n) = \sum_{i=1}^n i = n(n+1)/2 = (n^2/2) + (n/2) > (n^2/2)$ . With  $k = 1$  and  $M = 1/2$ , we have  $|f(n)| \geq M|n^2|$  for all  $n \geq k$ . Hence  $f \in \Omega(n^2)$ .  
 (b)  $\sum_{i=1}^n i^2 = 1^2 + 2^2 + \dots + n^2 > [n/2]^2 + \dots + n^2 > [n/2]^2 + \dots + [n/2]^2 = [(n+1)/2][n/2]^2 > n^3/8$ . With  $k = 1$  and  $M = 1/8$ , we have  $|g(n)| \geq M|n^3|$  for all  $n \geq k$ . Hence  $g \in \Omega(n^3)$ .  
 Alternately, for  $n \geq 1$ ,  $g(n) = \sum_{i=1}^n i^2 = n(n+1)(2n+1)/6 = (2n^3 + 3n^2 + n)/6 > n^3/6$ .

With  $k = 1$  and  $M = 1/6$ , we find that  $|g(n)| \geq M|n^3|$  for all  $n \geq k$  – so  $g \in \Omega(n^3)$ .

(c)  $\sum_{i=1}^n i^t = 1^t + 2^t + \dots + n^t > [n/2]^t + \dots + n^t > [n/2]^t + \dots + [n/2]^t = \lceil (n+1)/2 \rceil [n/2]^t > (n/2)^{t+1}$ . With  $k = 1$  and  $M = (1/2)^{t+1}$ , we have  $|h(n)| \geq M|n^{t+1}|$  for all  $n \geq k$ . Hence  $h \in \Omega(n^{t+1})$ .

14. Proof:  $f \in \Theta(g) \Rightarrow \exists m_1, m_2 \in \mathbb{R}^+ \exists k \in \mathbb{Z}^+ \forall n \geq k \ m_1|g(n)| \leq |f(n)| \leq m_2|g(n)| \Rightarrow \exists m_1 \in \mathbb{R}^+ \exists k \in \mathbb{Z}^+ \forall n \leq k \ m_1|g(n)| \leq |f(n)|$  and  $\exists m_2 \in \mathbb{R}^+ \exists k \in \mathbb{Z}^+ \forall n \geq k \ |f(n)| \leq m_2|g(n)| \Rightarrow f \in \Omega(g)$  and  $f \in O(g)$ .

Conversely,  $f \in \Omega(g) \Rightarrow \exists m_1 \in \mathbb{R}^+ \exists k_1 \in \mathbb{Z}^+ \forall n \geq k_1 \ m_1|g(n)| \leq |f(n)|$ . Likewise,  $f \in O(g) \Rightarrow \exists m_2 \in \mathbb{R}^+ \exists k_2 \in \mathbb{Z}^+ \forall n \geq k_2 \ |f(n)| \leq m_2|g(n)|$ . Let  $k = \max\{k_1, k_2\}$ . Then for all  $n \geq k$ ,  $m_1|g(n)| \leq |f(n)| \leq m_2|g(n)|$ , so  $f \in \Theta(g)$ .

15. Proof:  $f \in \Theta(g) \Rightarrow f \in \Omega(g)$  and  $f \in O(g)$  (from Exercise 14 of this section)  $\Rightarrow g \in O(f)$  and  $g \in \Omega(f)$  (from Exercise 12 of this section)  $\Rightarrow g \in \Theta(f)$ .
16. Proof: Part (a) follows from Exercises 14 and 13(a) of this section and part (a) of Example 5.68.

The situation is similar for parts (b) and (c).

## Section 5.8

1. (a)  $f \in O(n^2)$       (b)  $f \in O(n^3)$       (c)  $f \in O(n^2)$   
 (d)  $f \in O(\log_2 n)$     (e)  $f \in O(n \log_2 n)$
2. (a)  $f \in O(n)$       (b)  $f \in O(n)$
3. (a) For the following program segment the value of the integer  $n$ , and the values of the array entries  $A[1], A[2], A[3], \dots, A[n]$  are supplied beforehand. Also, the variables  $i$ ,  $\text{Max}$ , and  $\text{Location}$  that are used here are integer variables.

Begin

$\text{Max} := A[1];$

$\text{Location} := 1;$

    If  $n = 1$  then

        Begin

            Writeln ('The first occurrence of the maximum ');

            Write ('entry in the array is at position 1.')

        End;

    If  $n > 1$  then

        Begin

            For  $i := 2$  to  $n$  do

                If  $\text{Max} < A[i]$  then

                    Begin

```

        Max := A[i];
        Location := i
    End;
    Writeln (' The first occurrence of the maximum ');
    Write (' entry in the array is at position ', i:0, '.')
End
End;

```

(b) If, as in Exercise 2, we define the worst-case complexity function  $f(n)$  as the number of times the comparison  $\text{Max} < A[i]$  is executed, then  $f(n) = n - 1$  for all  $n \in \mathbb{Z}^+$ , and  $f \in \mathcal{O}(n)$ .

4. (a) For the following program segment the value of the integer  $n$ , and the values of the array entries  $A[1], A[2], A[3], \dots, A[n]$  are supplied earlier in the program. Also the variables  $i$ ,  $\text{Max}$ , and  $\text{Min}$  that are used here are integer variables.

```

Begin
    Min := A[1];
    Max := A[1];
    For i := 2 to n do
        Begin
            If A[i] < Min then
                Min := A[i];
            If A[i] > Max then
                Max := A[i];
        End;
    Writeln (' The minimum value in the array is ', Min :0);
    Write (' and the maximum value is ', Max:0, '.')
End;

```

(b) Here we define the worst-case time-complexity function  $f(n)$  as the number of comparisons that are executed in the For loop. Consequently,  $f(n) = 2(n - 1)$  for all  $n \in \mathbb{Z}^+$  and  $f \in \mathcal{O}(n)$ .

5. (a) Here there are five additions and ten multiplications.  
 (b) For the general case there are  $n$  additions and  $2n$  multiplications.
6. (a) For each iteration of the for loop there is one addition and one multiplication. Therefore, in total, there are five additions and five multiplications.  
 (b) For the general case there are  $n$  additions and  $n$  multiplications.
7. Proof: For  $n = 1$ , we find that  $a_1 = 0 = \lfloor 0 \rfloor = \lfloor \log_2 1 \rfloor$ , so the result is true in this first case.  
 Now assume the result true for all  $n = 1, 2, 3, \dots, k$ , where  $k \geq 1$ , and consider the cases for  $n = k + 1$ .

- (i)  $n = k + 1 = 2^m$ , where  $m \in \mathbb{Z}^+$ : Here  $a_n = 1 + a_{\lfloor n/2 \rfloor} = 1 + a_{2^{m-1}} = 1 + \lfloor \log_2 2^{m-1} \rfloor = 1 + (m - 1) = m = \lfloor \log_2 2^m \rfloor = \lfloor \log_2 n \rfloor$ ; and
- (ii)  $n = k + 1 = 2^m + r$ , where  $m \in \mathbb{Z}^+$  and  $0 < r < 2^m$ : Here  $2^m < n < 2^{m+1}$ , so we have
- (1)  $2^{m-1} < (n/2) < 2^m$ ;
  - (2)  $2^{m-1} = \lfloor 2^{m-1} \rfloor \leq \lfloor n/2 \rfloor < \lfloor 2^m \rfloor = 2^m$ ; and
  - (3)  $m - 1 = \log_2 2^{m-1} \leq \log_2 \lfloor n/2 \rfloor < \log_2 2^m = m$ .

Consequently,  $\lfloor \log_2 \lfloor n/2 \rfloor \rfloor = m - 1$  and  $a_n = 1 + a_{\lfloor n/2 \rfloor} = 1 + \lfloor \log_2 \lfloor n/2 \rfloor \rfloor = 1 + (m - 1) = m = \lfloor \log_2 n \rfloor$ .

Therefore it follows from the Alternative Form of the Principle of Mathematical Induction that  $a_n = \lfloor \log_2 n \rfloor$  for all  $n \in \mathbb{Z}^+$ .

8. We claim that  $a_n = \lfloor \log_2 n \rfloor$  for all  $n \in \mathbb{Z}^+$ .

Proof: When  $n = 1$  we have  $a_1 = 0 = \lfloor 0 \rfloor = \lfloor \log_2 1 \rfloor$ , and this establishes our basis step. For the inductive step we assume the result true for all  $n = 1, 2, 3, \dots, k$  ( $\geq 1$ ) and consider what happens at  $n = k + 1$ .

- (i)  $n = k + 1 = 2^m$ , where  $m \in \mathbb{Z}^+$ : Here  $a_n = 1 + a_{\lfloor n/2 \rfloor} = 1 + a_{2^{m-1}} = 1 + \lfloor \log_2 2^{m-1} \rfloor = 1 + (m - 1) = m = \lfloor \log_2 2^m \rfloor = \lfloor \log_2 n \rfloor$ .
- (ii)  $n = k + 1 = 2^m + r$ , where  $m \in \mathbb{Z}^+$  and  $0 < r < 2^m$ : Here  $2^m < n < 2^{m+1}$  and we find that

- (1)  $2^{m-1} < n/2 < 2^m$ ;
- (2)  $2^{m-1} = \lfloor 2^{m-1} \rfloor < \lfloor n/2 \rfloor \leq \lfloor 2^m \rfloor = 2^m$ ; and
- (3)  $m - 1 = \log_2 2^{m-1} < \log_2 \lfloor n/2 \rfloor \leq \log_2 2^m = m$ .

Therefore,  $\lfloor \log_2 \lfloor n/2 \rfloor \rfloor = m$  and  $a_n = 1 + a_{\lfloor n/2 \rfloor} = 1 + \lfloor \log_2 \lfloor n/2 \rfloor \rfloor = 1 + m = \lfloor \log_2 n \rfloor$ , since  $2^m < n < 2^{m+1} \Rightarrow \log_2 2^m = m < \log_2 n < m + 1 = \log_2 2^{m+1} \Rightarrow m < \lfloor \log_2 n \rfloor = m + 1$ .

Consequently, it follows from the Alternative Form of the Principle of Mathematical Induction that  $a_n = \lfloor \log_2 n \rfloor$  for all  $n \in \mathbb{Z}^+$ .

9. Here  $np = 3/4$  and  $q = 1 - np = 1/4$ , so  $E(X) = np(n + 1)/2 + nq = (3/4)[(n + 1)/2] + (1/4)n = (3/8)n + (3/8) + (1/4)n = (5/8)n + (3/8)$ .

10.  $Pr(X = i) = i/[n(n + 1)]$ , so  $\sum_{i=1}^n Pr(X = i) = \sum_{i=1}^n i/[n(n + 1)] = (1/[n(n + 1)]) \sum_{i=1}^n i = (1/[n(n + 1)])[n(n + 1)/2] = 1/2$  and  $q = 1 - (1/2) = 1/2$ .  
 $E(X) = \sum_{i=1}^n i^2/[n(n + 1)] + (1/2)n = [1/[n(n + 1)]] \sum_{i=1}^n i^2 + (1/2)n = \frac{1}{n(n+1)} \cdot \frac{n(n+1)(2n+1)}{6} + \frac{n}{2} = \frac{2n+1}{6} + \frac{n}{2} = \frac{5n}{6} + \frac{1}{6}$ .

11. a) **procedure** *LocateRepeat* ( $n$ : positive integer;  $a_1, a_2, a_3, \dots, a_n$ : integers)  
**begin**

```

    location := 0
    i := 2
    while i ≤ n and location = 0 do
        begin
            j := 1
            while j < i and location = 0 do

```

```

        if  $a_j = a_i$  then  $location := i$ 
        else  $j := j + 1$ 
         $i := i + 1$ 
    end
end { $location$  is the subscript of the first array entry that repeats a previous
array entry;  $location$  is 0 if the array contains  $n$  distinct integers}

```

b) For  $n \geq 2$ , let  $f(n)$  count the maximum number of times the second **while** loop is executed. The second **while** loop is executed at most  $n - 1$  times for each value of  $i$ , where  $2 \leq i \leq n$ . Consequently,  $f(n) = 1 + 2 + 3 + \dots + (n - 1) = (n - 1)(n)/2$ , which occurs when the array consists of  $n$  distinct integers or when the only repeat is  $a_{n-1}$  and  $a_n$ . Since  $(n - 1)(n)/2 = (1/2)(n^2 - n)$  we have  $f \in O(n^2)$ .

12.

```

a)  procedure FirstDecrease ( $n$ : positive integer;  $a_1, a_2, a_3, \dots, a_n$ : integers)
    begin
         $location := 0$ 
         $i := 2$ 
        while  $i \leq n$  and  $location = 0$  do
            if  $a_i < a_{i-1}$  then  $location := i$ 
            else  $i := i + 1$ 
        end { $location$  is the subscript of the first array entry that is smaller than its
immediate predecessor;  $location$  is 0 if the  $n$  integers in the array
are in increasing order}

```

b) For  $n \geq 2$ , let  $f(n)$  count the maximum number of comparisons made in the **while** loop. This is  $n - 1$ , which occurs if the integers in the array are in ascending order or if  $a_1 < a_2 < a_3 < \dots < a_{n-1}$  and  $a_n < a_{n-1}$ . Consequently,  $f \in O(n)$ .

### Supplementary Exercises

1. (a) If either  $A$  or  $B$  is  $\emptyset$  then  $A \times B = \emptyset = A \cap B$  and the result is true.

For  $A, B$  nonempty we find that:

$(x, y) \in (A \times B) \cap (B \times A) \Rightarrow (x, y) \in A \times B$  and  $(x, y) \in B \times A \Rightarrow (x \in A \text{ and } y \in B)$   
and  $(x \in B \text{ and } y \in A) \Rightarrow x \in A \cap B$  and  $y \in A \cap B \Rightarrow (x, y) \in (A \cap B) \times (A \cap B)$ ; and  
 $(x, y) \in (A \cap B) \times (A \cap B) \Rightarrow (x \in A \text{ and } x \in B)$  and  $(y \in A \text{ and } y \in B) \Rightarrow (x, y) \in A \times B$   
and  $(x, y) \in B \times A \Rightarrow (x, y) \in (A \times B) \cap (B \times A)$ .

Consequently,  $(A \times B) \cap (B \times A) = (A \cap B) \times (A \cap B)$ .

(b) If either  $A$  or  $B$  is  $\emptyset$  then  $A \times B = \emptyset = B \times A$  and the result follows.

If not, let  $(x, y) \in (A \times B) \cup (B \times A)$ . Then

$(x, y) \in (A \times B) \cup (B \times A) \Rightarrow (x, y) \in A \times B$  or  $(x, y) \in (B \times A) \Rightarrow (x \in A$  and  $y \in B)$  or  $(x \in B$  and  $y \in A) \Rightarrow (x \in A$  or  $x \in B)$  and  $(y \in A$  or  $y \in B) \Rightarrow x, y \in A \cup B \Rightarrow (x, y) \in (A \cup B) \times (A \cup B)$ .

2. (a) True (b) False: Let  $A = \{1, 2\}, B = \{x, y\}, f = \{(1, x), (2, y)\}$ .  
 (c) False: Let  $f: \mathbf{Z} \rightarrow \mathbf{Z}, f(x) = 2x$ . (d) True.  
 (e) False: Let  $A = \{1, 2\}, B = \{1, 2, 3\}, C = \{1, 2, 3, 4\}, f = \{(1, 1), (2, 2)\},$   
 $g = \{(1, 1), (2, 2), (3, 3)\}, h = \{(1, 1), (2, 2), (3, 4)\}$ .  
 (f) False. Let  $A = \{1, 2, 3, 4\}, B = \{5, 6\}, A_1 = \{1, 2\}, A_2 = \{2, 3, 4\},$   
 $f = \{(1, 5), (2, 6), (3, 5), (4, 5)\}$ . Then  $f(A_1 \cap A_2) = f(2) = \{6\}$ , but  $f(A_1) \cap f(A_2) = \{5, 6\}$ .  
 (g) True
3. (a)  $f(1) = f(1 \cdot 1) = 1 \cdot f(1) + 1 \cdot f(1)$ , so  $f(1) = 0$ .  
 (b)  $f(0) = 0$   
 (c) Proof (by Mathematical Induction): When  $a = 0$  the result is true, so consider  $a \neq 0$ . For  $n = 1, f(a^n) = f(a) = 1 \cdot a^0 \cdot f(a) = na^{n-1}f(a)$ , so the result follows in this first case, and this establishes our basis step. Assume the result true for  $n = k (\geq 1)$  – that is,  $f(a^k) = ka^{k-1}f(a)$ . For  $n = k + 1$  we have  $f(a^{k+1}) = f(a \cdot a^k) = af(a^k) + a^k f(a) = aka^{k-1}f(a) + a^k f(a) = ka^k f(a) + a^k f(a) = (k + 1)a^k f(a)$ . Consequently, the truth of the result for  $n = k + 1$  follows from the truth of the result for  $n = k$ . So by the Principle of Mathematical Induction the result is true for all  $n \in \mathbf{Z}^+$ .
4.  $2^{|A \times B|} = 262, 144 \Rightarrow |A \times B| = 18 \Rightarrow |A| = 2, |B| = 9$  or  $|A| = 3, |B| = 6$ .
5.  $(x, y) \in (A \cap B) \times (C \cap D) \iff x \in A \cap B, y \in C \cap D \iff (x \in A, y \in C)$  and  $(x \in B, y \in D) \iff (x, y) \in A \times C$  and  $(x, y) \in B \times D \iff (x, y) \in (A \times C) \cap (B \times D)$
6. (a)  $5!$  (b)  $4!$
7. If  $0 \leq x < 1$ , then  $\lfloor x \rfloor = 0$  and  $x^2 = 1/2$ . So  $x = 1/\sqrt{2}$ .  
 If  $1 \leq x < 2$ , then  $\lfloor x \rfloor = 1$  and  $x^2 = 3/2$ . So  $x = \sqrt{3/2}$ .  
 For  $k \in \mathbf{Z}^+$  and  $k \geq 2$ , if  $k \leq x < k + 1$ , then  $\lfloor x \rfloor = k$  and if  $x$  satisfies the given equation we have  $x^2 = k + (1/2)$ . But for  $k \geq 2$  we find that  $k(k - 1) > 0$ , so  $k(k - 1) \geq 1 > 1/2$ , and  $k^2 - k > 1/2$ . Now  $k^2 > k + (1/2) \Rightarrow k > \sqrt{k + (1/2)} = x$  and we do *not* have  $k \leq x < k + 1$ .  
 Finally, let  $k \in \mathbf{Z}^+$  and consider  $-k \leq x < -k + 1$ . Then  $x^2 - \lfloor x \rfloor = x^2 - (-k) = x^2 + k$ , and  $x^2 - \lfloor x \rfloor = 1/2 \Rightarrow x^2 = -k + 1/2 < 0$ , so  $x$  cannot be a real number.  
 Consequently, there are only two real numbers that satisfy the equation  $x^2 - \lfloor x \rfloor = 1/2$  — namely,  $x = 1/\sqrt{2}$  and  $x = \sqrt{3/2}$ .
8. Proof: First we show that the result holds for the first part of the recursive definition. Since  $2 \cdot 1 = 2 \geq 1$  we find the result true in part (1). In order to complete the proof we need to verify that every ordered pair  $(s, t)$  in  $\mathcal{R}$  that results from part (2) of the definition satisfies the condition  $2s \geq t$ . We consider three cases:

(i)  $(a + 1, b)$  with  $(a, b) \in \mathcal{R}$ : Here we have  $2a \geq b$ , and since  $a + 1 \geq a$  it follows that  $2(a + 1) \geq 2a \geq b$ ;

(ii)  $(a + 1, b + 1)$  with  $(a, b) \in \mathcal{R}$ : Now we find that  $2a \geq b \Rightarrow 2a + 2 \geq b + 1 \Rightarrow 2(a + 1) \geq b + 1$ ; and

(iii)  $(a + 1, b + 2)$  with  $(a, b) \in \mathcal{R}$ : In this last case it follows that  $2a \geq b \Rightarrow 2a + 2 \geq b + 2 \Rightarrow 2(a + 1) \geq b + 2$ .

Consequently, for all  $(a, b) \in \mathcal{R}$  we have  $2a \geq b$ .

9. (a)  $f^2(x) = f(f(x)) = a(f(x) + b) - b = a[(a(x + b) - b) + b] - b = a^2(x + b) - b$   
 $f^3(x) = f(f^2(x)) = f(a^2(x + b) - b) = a[(a^2(x + b) - b) + b] - b = a^3(x + b) - b$

(b) Conjecture: For  $n \in \mathbf{Z}^+$ ,  $f^n(x) = a^n(x + b) - b$ . Proof (by Mathematical Induction): The formula is true for  $n = 1$  - by the definition of  $f(x)$ . Hence we have our basis step. Assume the formula true for  $n = k (\geq 1)$  - that is,  $f^k(x) = a^k(x + b) - b$ . Now consider  $n = k + 1$ . We find that  $f^{k+1}(x) = f(f^k(x)) = f(a^k(x + b) - b) = a[(a^k(x + b) - b) + b] - b = a^{k+1}(x + b) - b$ . Since the truth of the formula at  $n = k$  implies the truth of the formula at  $n = k + 1$ , it follows that the formula is valid for all  $n \in \mathbf{Z}^+$  - by the Principle of Mathematical Induction.

10. Let  $n = |A| - |A_1|$ . Since  $|B|^n$  is the number of ways to extend  $f$  to  $A$  and  $|B|^n = 6^n = 216$ , then  $n = 3$  and  $|A| = 8$ .

11. (a)  $(7 \times 6 \times 5 \times 4 \times 3)/(7^5) \doteq 0.15$ .

(b) For the computer program the elements of  $B$  are replaced by  $\{1, 2, 3, 4, 5, 6, 7\}$ .

```

10  Random
20  Dim F(5)
30  For I = 1 To 5
40      F(I) = Int(Rnd*7 + 1)
50  Next I
60  For J = 2 To 5
70      For K = 1 To J - 1
80          If F(J) = F(K) then GOTO 120
90      Next K
100 Next J
110 GOTO 140
120 C = C + 1
130 GOTO 10
140 C = C + 1
150 Print "After "; C; " generations the resulting"
160 Print "function is one-to-one."
170 Print "The one-to-one function is given as:"
180 For I = 1 To 5
190     Print "("; I; ", "; F(I); ")"

```

12. For each subset  $A$  of  $S$ , let  $s_A$  denote the sum of the elements of  $A$ . Consider only those nonempty subsets  $A$  of  $S$  where  $|A| \leq 5$ . There are  $2^7 - 1 - 1 - 7 = 119$  such subsets and here  $1 \leq s_A \leq 20 + 21 + 22 + 23 + 24 = 110$ . The result follows by the Pigeonhole Principle for there are 119 subsets (pigeons) and 110 possible sums (pigeonholes).
13. For  $1 \leq i \leq 10$ , let  $x_i$  be the number of letters typed on day  $i$ . Then  $x_1 + x_2 + x_3 + \dots + x_8 + x_9 + x_{10} = 84$ , or  $x_3 + \dots + x_8 = 54$ . Suppose that  $x_1 + x_2 + x_3 < 25$ ,  $x_2 + x_3 + x_4 < 25$ ,  $\dots$ ,  $x_8 + x_9 + x_{10} < 25$ . Then  $x_1 + 2x_2 + 3(x_3 + \dots + x_8) + 2x_9 + x_{10} < 8(25) = 200$ , or  $3(x_3 + \dots + x_8) < 160$ . Consequently,  $54 = x_3 + \dots + x_8 < (160)/3 = 53 \frac{1}{3}$ .
14. If two elements in  $\{x_1, x_2, \dots, x_7\}$  have the same units digit then their difference is divisible by 10. If this does not happen consider the ten possible units digits as follows:  $\{0\}$ ,  $\{1, 9\}$ ,  $\{2, 8\}$ ,  $\{3, 7\}$ ,  $\{4, 6\}$ ,  $\{5\}$  – these are the pigeonholes for the problem. When the seven pigeons  $\{x_1, x_2, \dots, x_7\}$  go to the pigeonholes where their units digits are located, at least one two-element subset is filled and those two numbers (pigeons) will sum to a multiple of 10.
15. For  $\prod_{k=1}^n (k - i_k)$  to be odd,  $(k - i_k)$  must be odd for all  $1 \leq k \leq n$ , i.e., one of  $k, i_k$  must be even and the other odd. Since  $n$  is odd,  $n = 2m + 1$  and in the list  $1, 2, \dots, n$ , there are  $m$  even integers and  $m + 1$  odd integers. Let  $1, 3, 5, \dots, n$  be the pigeons and  $i_1, i_3, i_5, \dots, i_n$  the pigeonholes. At most  $m$  of the pigeonholes can be even integers, so  $(k - i_k)$  must be even for at least one  $k = 1, 3, 5, \dots, n$ . Consequently,  $\prod_{k=1}^n (k - i_k)$  is even.
16. (a) The answer is the number of onto functions  $f : A \rightarrow B$  where  $|A| = 10$  (weekly chores) and  $|B| = 3$  (for the three young men). There are  $3!S(10, 3)$  such functions.  
 (b)  $2!S(9, 2)$  (Thomas only mows the lawn) +  $3!S(9, 3)$  (Thomas does more than just mow the lawn).
17. Let the  $n$  distinct objects be  $x_1, x_2, \dots, x_n$ . Place  $x_n$  in a container. Now there are two distinct containers. For each of  $x_1, x_2, \dots, x_{n-1}$  there are two choices and this gives  $2^{n-1}$  distributions. Among these there is one where  $x_1, x_2, \dots, x_{n-1}$  are in the container with  $x_n$ , so we remove this distribution and find  $S(n, 2) = 2^{n-1} - 1$ .
18. (a)  $\binom{12}{9}$  (b)  $5!S(9, 5)$   
 (c)  $4!S(7, 4)$  (Donald gets only the two books on basketball) +  $5!S(7, 5)$  (Donald gets the two books on basketball and at least one other book.)
19. (a) and (b)  $m!S(n, m)$
20.  $S(n, n - 2)$  is the number of ways to place  $n$  distinct objects into  $n - 2$  identical containers

with no container left empty. There are two cases. One container contains three objects and the others one. This can happen in  $\binom{n}{3}$  ways. The other possibility is that two containers each contain two objects and the others one. This happens in  $(1/2)\binom{n}{2}\binom{n-2}{2} = (n!)/[2!2!(n-4)!] = 3\binom{n}{4}$  ways.

21. Fix  $m = 1$ . For  $n = 1$  the result is true. Assume  $f \circ f^k = f^k \circ f$  and consider  $f \circ f^{k+1}$ .  $f \circ f^{k+1} = f \circ (f \circ f^k) = f \circ (f^k \circ f) = (f \circ f^k) \circ f = f^{k+1} \circ f$ . Hence  $f \circ f^n = f^n \circ f$  for all  $n \in \mathbf{Z}^+$ . Now assume that for  $t \geq 1$ ,  $f^t \circ f^n = f^n \circ f^t$ . Then  $f^{t+1} \circ f^n = (f \circ f^t) \circ f^n = f \circ (f^t \circ f^n) = f \circ (f^n \circ f^t) = (f \circ f^n) \circ f^t = (f^n \circ f) \circ f^t = f^n \circ (f \circ f^t) = f^n \circ f^{t+1}$ , so  $f^m \circ f^n = f^n \circ f^m$  for all  $m, n \in \mathbf{Z}^+$ .

22. (b)  $y \in f(\bigcap_{i \in I} A_i) \iff y = f(x)$ , for some  $x \in \bigcap_{i \in I} A_i \implies y \in f(A_i)$ , for all  $i \in I \iff y \in \bigcap_{i \in I} f(A_i)$ .

(c) From part (b),  $f(\bigcap_{i \in I} A_i) \subseteq \bigcap_{i \in I} f(A_i)$ . For the opposite inclusion let  $y \in \bigcap_{i \in I} f(A_i)$ . Then  $y \in f(A_i)$  for all  $i \in I$ , so  $y = f(x_i)$ ,  $x_i \in A_i$ , for each  $i \in I$ . Since  $f$  is one-to-one, all of these  $x_i$ 's,  $i \in I$ , yield only one element  $x \in \bigcap_{i \in I} A_i$ . Hence  $y = f(x) \in f(\bigcap_{i \in I} A_i)$ , so  $\bigcap_{i \in I} f(A_i) \subseteq f(\bigcap_{i \in I} A_i)$  and the equality follows.

The proof for part (a) is done in a similar way.

23. Proof: Let  $a \in A$ . Then

$$f(a) = g(f(f(a))) = f(g(f(f(f(a)))))) = f(g \circ f^3(a)).$$

From  $f(a) = g(f(f(a)))$  we have  $f^2(a) = (f \circ f)(a) = f(g(f(f(a))))$ . So  $f(a) = f(g \circ f^3(a)) = f(g(f(f(f(a)))))) = f^2(f(a)) = f^2(g(f^2(a))) = f(f(g(f(f(a)))))) = f(g(f(a))) = g(a)$ .

Consequently,  $f = g$ .

24. (a)  $n^{(n \times n)} = n^{(n^2)}$       (b)  $n^{(n^3)}$       (c)  $n^{(n^k)}$

(d) Since  $|A| = n$ , there are  $n$  choices for each selection of size  $k$ , with repetitions allowed, from the set  $A$  of size  $n$ . There are  $r = \binom{n+k-1}{k}$  possible selections and  $n^r$  commutative  $k$ -ary operations on  $A$ .

25. a) Note that  $2 = 2^1$ ,  $16 = 2^4$ ,  $128 = 2^7$ ,  $1024 = 2^{10}$ ,  $8192 = 2^{13}$ , and  $65536 = 2^{16}$ . Consider the exponents on 2. If four numbers are selected from  $\{1, 4, 7, 10, 13, 16\}$ , there is at least one pair whose sum is 17. Hence if four numbers are selected from  $S$ , there are two numbers whose product is  $2^{17} = 131072$ .

b) Let  $a, b, c, d, n \in \mathbf{Z}^+$ . Let  $S = \{b^a, b^{a+d}, b^{a+2d}, \dots, b^{a+nd}\}$ . If  $\lceil \frac{n}{2} \rceil + 1$  numbers are selected from  $S$  then there are at least two of them whose product is  $b^{2a+nd}$ .

26. (a)  $\chi_{A \cap B}, \chi_A \cdot \chi_B$  both have domain  $\mathcal{U}$  and codomain  $\{0, 1\}$ . For each  $x \in \mathcal{U}$ ,  $\chi_{A \cap B}(x) = 1$  iff  $x \in A \cap B$  iff  $x \in A$  and  $x \in B$  iff  $\chi_A(x) = 1$  and  $\chi_B(x) = 1$ . Also,  $\chi_{A \cap B}(x) =$

0 iff  $x \notin A \cap B$  iff  $x \notin A$  or  $x \notin B$  iff  $\chi_A(x) = 0$  or  $\chi_B(x) = 0$  iff  $\chi_A \cdot \chi_B(x) = 0$ . Hence  $\chi_{A \cap B} = \chi_A \cdot \chi_B$ .

(b) The proof here is similar to that of part (a).

(c)  $\chi_{\bar{A}}(x) = 1$  iff  $x \in \bar{A}$  iff  $x \notin A$  iff  $\chi_A(x) = 0$  iff  $(1 - \chi_A)(x) = 1$ .  $\chi_{\bar{A}}(x) = 0$  iff  $x \notin \bar{A}$  iff  $x \in A$  iff  $\chi_A(x) = 1$  iff  $(1 - \chi_A)(x) = 0$ . Hence  $\chi_{\bar{A}} = 1 - \chi_A$ .

27.  $f \circ g = \{(x, z), (y, y), (z, x)\}; g \circ f = \{(x, x), (y, z), (z, y)\};$

$f^{-1} = \{(x, z), (y, x), (z, y)\}; g^{-1} = \{(x, y), (y, x), (z, z)\};$

$(g \circ f)^{-1} = \{(x, x), (y, z), (z, y)\} = f^{-1} \circ g^{-1}; g^{-1} \circ f^{-1} = \{(x, z), (y, y), (z, x)\}.$

28. (a)  $f^{-1}(8) = \{x | 5x + 3 = 8\} = \{1\}.$

(b)  $|x^2 + 3x + 1| = 1 \implies x^2 + 3x + 1 = 1$  or  $x^2 + 3x + 1 = -1 \implies x^2 + 3x = 0$  or  $x^2 + 3x + 2 = 0 \implies (x)(x + 3) = 0$  or  $(x + 2)(x + 1) = 0 \implies x = 0, -3$  or  $x = -1, -2$ . Hence  $g^{-1}(1) = \{-3, -2, -1, 0\}.$

(c)  $\{-8/5, -8/3\}$

29. Under these conditions we know that  $f^{-1}(\{6, 7, 9\}) = \{2, 4, 5, 6, 9\}$ . Consequently we have

(i) two choices for each of  $f(1)$ ,  $f(3)$ , and  $f(7)$  – namely, 4 or 5;

(ii) two choices for each of  $f(8)$  and  $f(10)$  – namely, 8 or 10; and

(iii) three choices for each of  $f(2)$ ,  $f(4)$ ,  $f(5)$ ,  $f(6)$ , and  $f(9)$  – namely, 6, 7, or 9.

Therefore, by the rule of product, it follows that the number of functions satisfying these conditions is  $2^3 \cdot 2^2 \cdot 3^5 = 7776$ .

30. Since  $f^1 = f$  and  $(f^{-1})^1 = f^{-1}$ , the result is true for  $n = 1$ . Assume the result for  $n = k$ :  $(f^k)^{-1} = (f^{-1})^k$ . For  $n = k + 1$ ,  $(f^{k+1})^{-1} = (f \circ f^k)^{-1} = (f^k)^{-1} \circ (f^{-1}) = (f^{-1})^k \circ (f^{-1})^1 = (f^{-1})^1 \circ (f^{-1})^k$  (by Exercise 21)  $= (f^{-1})^{k+1}$ . Therefore, by the Principle of Mathematical Induction, the result is true for all  $n \in \mathbb{Z}^+$ .

31. (a)  $(\pi \circ \sigma)(x) = (\sigma \circ \pi)(x) = x$

(b)  $\pi^n(x) = x - n; \sigma^n(x) = x + n (n \geq 2).$

(c)  $\pi^{-n}(x) = x + n; \sigma^{-n}(x) = x - n (n \geq 2).$

32. (a)  $\tau(n) = (e_1 + 1)(e_2 + 1) \cdots (e_k + 1)$

(b)  $k = 2: \tau(2) = \tau(3) = \tau(5) = 2$

$k = 3: \tau(2^2) = \tau(3^2) = \tau(5^2) = 3$

$k = 4: \tau(6) = \tau(8) = \tau(10) = 4$

$k = 5: \tau(2^4) = \tau(3^4) = \tau(5^4) = 5$

$k = 6: \tau(12) = \tau(18) = \tau(20) = 6$

(c) For all  $k > 1$  and any prime  $p$ ,  $\tau(p^{k-1}) = k$ .

(d) Let  $a = p_1^{e_1} p_2^{e_2} \cdots p_k^{e_k}$  and  $b = q_1^{f_1} q_2^{f_2} \cdots q_t^{f_t}$ , where  $p_1, p_2, \dots, p_k, q_1, q_2, \dots, q_t$  are  $k + t$  distinct primes, and  $e_1, e_2, \dots, e_k, f_1, f_2, \dots, f_t \in \mathbb{Z}^+$ . Then

$\tau(ab) = (e_1 + 1)(e_2 + 1) \cdots (e_k + 1)(f_1 + 1)(f_2 + 1) \cdots (f_t + 1)$

$$= [(e_1 + 1)(e_2 + 1) \cdots (e_k + 1)][(f_1 + 1)(f_2 + 1) \cdots (f_i + 1)] = \tau(a)\tau(b).$$

33. (a) Here there are eight distinct primes and each subset  $A$  satisfying the stated property determines a distribution of the eight distinct objects in  $X = \{2, 3, 5, 7, 11, 13, 17, 19\}$  into four identical containers with no container left empty. There are  $S(8, 4)$  such distributions.

(b)  $S(n, m)$

34. Define  $f : \mathbf{Z}^+ \rightarrow \mathbf{R}$  by  $f(n) = 1/n$ .

35. (a) Let  $m = 1$  and  $k = 1$ . Then for all  $n \geq k$ ,  $|f(n)| \leq 2 < 3 \leq |g(n)| = m|g(n)|$ , so  $f \in O(g)$ .

- (b) Let  $m = 4$  and  $k = 1$ . Then for all  $n \geq k$ ,  $|g(n)| \leq 4 = 4 \cdot 1 \leq 4|f(n)| = m|f(n)|$ , so  $g \in O(f)$ .

36. (a)  $f \in O(f_1) \implies \exists m_1 \in \mathbf{R}^+ \exists k_1 \in \mathbf{Z}^+$  such that  $|f(n)| \leq m_1|f_1(n)| \forall n \geq k_1$ .

$$g \in O(g_1) \implies \exists m_2 \in \mathbf{R}^+ \exists k_2 \in \mathbf{Z}^+ \text{ such that } |g(n)| \leq m_2|g_1(n)| \forall n \geq k_2.$$

Let  $m = \max\{m_1, m_2\}$ . Then for all  $n \geq \max\{k_1, k_2\}$ ,  $|(f + g)(n)| = |f(n) + g(n)| = |f(n)| + |g(n)| \leq m_1|f_1(n)| + m_2|g_1(n)| \leq m(|f_1(n)| + |g_1(n)|) = m|f_1(n) + g_1(n)| = m|(f_1 + g_1)(n)|$ , so  $(f + g) \in O(f_1 + g_1)$ .

- (b) Let  $f, f_1, g, g_1 : \mathbf{Z}^+ \rightarrow \mathbf{R}$  be defined by  $f(n) = n, f_1(n) = 1 - n, g(n) = 1, g_1(n) = n$ .

37. First note that if  $\log_a n = r$ , then  $n = a^r$  and  $\log_b n = \log_b(a^r) = r \log_b a = (\log_b a)(\log_a n)$ . Now let  $m = (\log_b a)$  and  $k = 1$ . Then for all  $n \geq k$ ,  $|g(n)| = \log_b n = (\log_b a)(\log_a n) = m|f(n)|$ , so  $g \in O(f)$ .

Finally, with  $m = (\log_b a)^{-1} = \log_a b$  and  $k = 1$ , we find that for all  $n \geq k$ ,  $|f(n)| = \log_a n = (\log_a b)(\log_b n) = m|g(n)|$ . Hence  $f \in O(g)$ .

**CHAPTER 6**  
**LANGUAGES: FINITE STATE MACHINES**

**Section 6.1**

1. (a) 25; 125                                  (b)  $\sum_{i=0}^5 5^i = 3906$
2. (a)  $4^4$                                   (b)  $\binom{5}{2}(3^3)$                                   (c)  $3^5$                                   (d)  $3^5 + \binom{5}{2}3^3 + \binom{5}{4}3$
3. 12
4. (a) 0                                  (b) 0                                  (c) 1                                  (d) 2  
 (e) 3                                  (f) 4                                  (g) 1                                  (h) 0
5.  $\sum_{i=1}^4 5^i$
6. There are 100 substrings of length 1:  $x_1, x_2, \dots, x_{100}$ ; 99 substrings of length 2:  $x_1x_2, x_2x_3, \dots, x_{99}x_{100}; \dots$ ; 1 substring of length 100:  $x_1x_2 \dots x_{100}$ . So there are  $100 + 99 + \dots + 1 = \sum_{i=1}^{100} i = (100)(101)/2 = 5050$  nonempty substrings in total.
7. (a)  $\{00, 11, 000, 111, 0000, 1111\}$   
 (b)  $\{0, 1\}$   
 (c)  $\Sigma^* - \{\lambda, 00, 11, 000, 111, 0000, 1111\}$   
 (d)  $\{0, 1, 00, 11\}$   
 (e)  $\Sigma^*$   
 (f)  $\Sigma^* - \{0, 1, 00, 11\} = \{\lambda, 01, 10\} \cup \{w \mid \|w\| \geq 3\}$
8. (a)  $AB = \{1000, 101, 1100, 111\}$   
 (b)  $BA = \{0010, 0011, 110, 111\}$   
 (c)  $A^3 = \{101010, 101011, 101110, 111010, 101111, 111011, 111110, 111111\}$   
 (d)  $B^2 = \{0000, 001, 100, 11\}$ .
9. (a)  $x \in AC \implies x = ac$ , for some  $a \in A, c \in C \implies x \in BD$ , since  $A \subseteq B, C \subseteq D$ .  
 (b) If  $A\emptyset \neq \emptyset$ , let  $x \in A\emptyset$ .  $x \in A\emptyset \implies x = yz$ , for some  $y \in A, z \in \emptyset$ . But  $z \in \emptyset$  is impossible. Hence  $A\emptyset = \emptyset$ . [In like manner  $\emptyset A = \emptyset$ ].
10. (a)  $AB = \{xy, xyx\}$                                   (b)  $BA = \{xy, xxy\}$                                   (c)  $B^3 = \{\lambda, x, x^2, x^3\}$   
 (d)  $B^+ = \{x^n \mid n \in \mathbb{Z}^+\}$                                   (e)  $A^* = \{\lambda, xy, xyxy, \dots\} = \{\lambda\} \cup \{(xy)^n \mid n \in \mathbb{Z}^+\}$
11. For any alphabet  $\Sigma$ , let  $B \subseteq \Sigma$ . Then, if  $A = B^*$ , it follows from part (f) of Theorem 6.2 that  $A^* = (B^*)^* = B^* = A$ .

12. (a) Yes (b) Yes (c) Yes  
(d) Yes (e) No (f) Yes
13. (a) Here  $A^*$  consists of all strings  $x$  of even length where if  $x \neq \lambda$ , then  $x$  starts with 0 and ends with 1, and the symbols (0 and 1) alternate.  
(b) In this case  $A^*$  contains precisely those strings made up of  $3n$  0's, for  $n \in \mathbb{N}$ .  
(c) Here a string  $x \in A^*$  if (and only if)  
(i)  $x$  is a string of  $n$  0's, for  $n \in \mathbb{N}$ ; or  
(ii)  $x$  is a string that starts and ends with 0, and has at least one 1 – but no consecutive 1's.  
(d) For this last case  $A^*$  consists of the following:  
(i) Any string of  $n$  1's, for  $n \in \mathbb{N}$ ; and  
(ii) Any string that starts with 1 and contains at least one 0, but no consecutive 0's.
14. There are five possible choices:  
(1)  $A = \{\lambda\}$ ,  $B = \{01, 000, 0101, 0111, 01000, 010111\}$ ;  
(2)  $A = \{01, 000, 0101, 0111, 01000, 010111\}$ ,  $B = \{\lambda\}$ ;  
(3)  $A = \{0\}$ ,  $B = \{1, 00, 101, 111, 1000, 10111\}$ ;  
(4)  $A = \{0, 010\}$ ,  $B = \{1, 00, 111\}$ ; and  
(5)  $A = \{\lambda, 01\}$ ,  $B = \{01, 000, 0111\}$ .
15. Let  $\Sigma$  be an alphabet with  $\emptyset \neq A \subseteq \Sigma^*$ . If  $|A| = 1$  and  $x \in A$ , then  $xx = x$  since  $A^2 = A$ . But  $\|xx\| = 2\|x\| = \|x\| \implies \|x\| = 0 \implies x = \lambda$ . If  $|A| > 1$ , let  $x \in A$  where  $\|x\| > 0$  but  $\|x\|$  is minimal. Then  $x \in A^2 \implies x = yz$ , for some  $y, z \in A$ . Since  $\|x\| = \|y\| + \|z\|$ , if  $\|y\|, \|z\| > 0$ , then one of  $y, z$  is in  $A$  with length smaller than  $\|x\|$ . Consequently, one of  $\|y\|$  or  $\|z\|$  is 0, so  $\lambda \in A$ .
16. (a)  $p_a, s_a, r$   
(b)  $r, d$  are onto;  $p_a(\Sigma^*) = \{a\}\Sigma^*$ ;  $s_a(\Sigma^*) = \Sigma^*\{a\}$   
(c)  $r$  is invertible and  $r^{-1} = r$ .  
(d) 25; 125;  $5^{n/2}$  for  $n$  even,  $5^{(n+1)/2}$  for  $n$  odd.  
(e)  $(d \circ p_a)(x) = x = (r \circ d \circ r \circ s_a)(x)$   
(f)  $r^{-1}(B) = \{ea, ia, oa, oo, oie, uuoie\}$   
 $p_a^{-1}(B) = \{e, i, o\}$ .  
 $s_a^{-1}(B) = \emptyset$   
 $|d^{-1}(B)| = |\bigcup_{x \in B} d^{-1}(x)| = \sum_{x \in B} d^{-1}(x) = \sum_{x \in B} 5 = 6(5) = 30$
17. If  $A = A^2$  then it follows by mathematical induction that  $A = A^n$  for all  $n \in \mathbb{Z}^+$ . Hence  $A = A^+$ . From Exercise 15 we know that  $A = A^2 \implies \lambda \in A$ , so  $A = A^*$ .
18. Theorem 6.1(b):  $x \in (AB)C \iff x = (ab)c$ , for some  $a \in A, b \in B, c \in C \iff x = (a_1 a_2 \dots a_\ell b_1 b_2 \dots b_m)(c_1 c_2 \dots c_n)$ , where  $a_i \in A, 1 \leq i \leq \ell, b_j \in B, 1 \leq j \leq m, c_k \in C, 1 \leq k \leq n \iff x = a_1 a_2 \dots a_\ell b_1 b_2 \dots b_m c_1 c_2 \dots c_n$ , where  $a_i \in A, 1 \leq i \leq \ell, b_j \in B, 1 \leq j \leq m, c_k \in C, 1 \leq k \leq n \iff x = (a_1 a_2 \dots a_\ell)(b_1 b_2 \dots b_m c_1 c_2 \dots c_n)$ , where

$a_i \in A, 1 \leq i \leq \ell, b_j \in B, 1 \leq j \leq m, c_k \in C, 1 \leq k \leq n \iff x \in A(BC)$ . Hence  $(AB)C = A(BC)$ .

Theorem 6.2(b): For  $a \in A, a = \lambda a$  with  $\lambda \in B^*$ . Hence  $A \subseteq B^*A$ .

Theorem 6.2(f): From Theorem 6.2(a)  $A^* \subseteq A^*A^*$ . Conversely,  $x \in A^*A^* \implies x = yz$  where  $y = a_1a_2 \dots a_m, z = a'_1a'_2 \dots a'_n$ , with  $a_i, a'_j \in A$ , for  $1 \leq i \leq m, 1 \leq j \leq n$ . Hence  $x \in A^*$ , so  $A^*A^* \subseteq A^*$  and the equality follows.

Since  $(A^*)^* = \bigcup_{n=0}^{\infty} (A^*)^n$ , it follows that  $A^* \subseteq (A^*)^*$ . Conversely, if  $x \in (A^*)^*$ , then  $x = x_1x_2 \dots x_n$ , where  $x_i \in A^*$ , for  $1 \leq i \leq n$ . Each  $x_i = a_{i1}a_{i2} \dots a_{ik_i}$ , where  $a_{ij} \in A, 1 \leq j \leq k_i$ . Hence  $x \in A^*$ , so  $(A^*)^* \subseteq A^*$  and  $(A^*)^* = A^*$ .

$(A^*)^+ = \bigcup_{n=1}^{\infty} (A^*)^n \subseteq \bigcup_{n=0}^{\infty} (A^*)^n = (A^*)^*$ . If  $x \in (A^*)^*$ , then  $x = x_1x_2 \dots x_n$ , where  $x_i \in A^*$ , for  $1 \leq i \leq n$ . Then  $x = a_{11}a_{12} \dots a_{1k_1}a_{21}a_{22} \dots a_{2k_2} \dots a_{n1} \dots a_{nk_n} \in A^* \subseteq \bigcup_{n=1}^{\infty} (A^*)^n = (A^*)^+$ , so  $(A^*)^* = (A^*)^+$ .

Since  $A^+ \subseteq A^*, (A^+)^* \subseteq (A^*)^*$  by part (d) of this theorem. For  $x \in (A^*)^*$ , if  $x = \lambda$ , then  $x \in (A^+)^*$ . If  $x \neq \lambda$ , then as above  $x = a_{11}a_{12} \dots a_{1k_1}a_{21} \dots a_{2k_2} \dots a_{n1} \dots a_{nk_n} \in A^+ \subseteq (A^+)^*$  and the result follows.

19. By Definition 6.11  $AB = \{ab | a \in A, b \in B\}$ , and since it is possible to have  $a_1b_1 = a_2b_2$  with  $a_1, a_2 \in A, a_1 \neq a_2$ , and  $b_1, b_2 \in B, b_1 \neq b_2$ , it follows that  $|AB| \leq |A \times B| = |A||B|$ .

20. (a)  $\{y\}^*x\{y\}^*$                       (b)  $\{y\}^*x\{y\}^*x\{y\}^*$                       (c)  $x\{x, y\}^*$   
 (d)  $\{x, y\}^*yxy$                       (e)  $(x\{x, y\}^*) \cup (\{x, y\}^*yxy)$   
 (f)  $[(x\{x, y\}^*) \cup (\{x, y\}^*yxy)] - [x\{x, y\}^*yxy]$

21. (a) The words 001 and 011 have length 3 and are in  $A$ . The words 00011 and 00111 have length 5 and they are also in  $A$ .

(b) From step (1) we know that  $1 \in A$ . Then by applying step (2) three times we get

- (i)  $1 \in A \implies 011 \in A$ ;  
 (ii)  $011 \in A \implies 00111 \in A$ ; and  
 (iii)  $00111 \in A \implies 0001111 \in A$ .

(c) If 00001111 were in  $A$ , then from step (2) we see that this word would have to be generated from 000111 (in  $A$ ). Likewise,  $000111 \in A \implies 0011$  is in  $A \implies 01$  is in  $A$ . However, there are no words in  $A$  of length 2 — in fact, there are no words of even length in  $A$ .

22. (a) (1)  $\lambda \in A$ ; and  
 (2) If  $x \in A$ , then each of the following is also in  $A$ :  
 (i)  $x1$                       (ii)  $1x$                       (iii)  $00x$                       (iv)  $x00$                       (v)  $0x0$   
 [And no other string of 0's and 1's is in  $A$ .]

- (b) (1)  $\lambda \in A$ ; and  
 (2) For each  $x \in A$  the strings  $1x$  and  $x0$  are also in  $A$ .

23.

(a) **Steps**

1.  $()$  is in  $A$ .
2.  $(( ))$  is in  $A$ .
3.  $(( ))( )$  is in  $A$ .

**Reasons**

- Part (1) of the recursive definition  
 Step 1 and part (2(ii)) of the definition  
 Steps 1, 2, and part (2(i)) of the definition

(b) **Steps**

1.  $()$  is in  $A$ .
2.  $(( ))$  is in  $A$ .
3.  $(( ))( )$  is in  $A$ .
4.  $(( ))( )( )$  is in  $A$ .

**Reasons**

- Part (1) of the recursive definition  
 Step 1 and part (2(ii)) of the definition  
 Steps 1, 2, and part (2(i)) of the definition  
 Steps 1, 3, and part (2(i)) of the definition

(c) **Steps**

1.  $()$  is in  $A$ .
2.  $()( )$  is in  $A$ .
3.  $(( ))( )$  is in  $A$ .
4.  $()( )( )$  is in  $A$ .

**Reasons**

- Part (1) of the recursive definition  
 Step 1 and part (2(i)) of the definition  
 Step 2 and part (2(ii)) of the definition  
 Steps 1, 3, and part (2(i)) of the definition

24. (1)  $\lambda \in A$  and  $s \in A$  for all  $s \in \Sigma$ ; and  
 (2) For each  $x \in A$  and  $s \in \Sigma$ , the string  $sxs$  is also in  $A$ .  
 [No other string from  $\Sigma^*$  is in  $A$ .]

25. Length 3:  $\binom{3}{0} + \binom{2}{1} = 3$

Length 4:  $\binom{4}{0} + \binom{3}{1} + \binom{2}{2} = 5$

Length 5:  $\binom{5}{0} + \binom{4}{1} + \binom{3}{2} = 8$

Length 6:  $\binom{6}{0} + \binom{5}{1} + \binom{4}{2} + \binom{3}{3} = 13$  [Here the summand  $\binom{6}{0}$  counts the strings where there are no 0s; the summand  $\binom{5}{1}$  counts the strings where we arrange the symbols 1, 1, 1, 1, 00; the summand  $\binom{4}{2}$  is for the arrangements of 1, 1, 00, 00; and the summand  $\binom{3}{3}$  counts the arrangements of 00, 00, 00.]

26. [Here  $\binom{9}{1}$  counts the arrangements for one 111 and eight 00's;  $\binom{8}{3}$  counts the arrangements for three 111's and five 00's; and  $\binom{7}{5}$  is for the arrangements of five 111's and two 00's.]

- $A$ : (1)  $\lambda \in A$   
 (2) If  $a \in A$ , then  $0a0, 0a1, 1a0, 1a1 \in A$ .

27.

- $B$ : (1)  $0, 1 \in A$ .  
 (2) If  $a \in A$ , then  $0a0, 0a1, 1a0, 1a1 \in A$ .

28. Of the  $3 \cdot 3 \cdot 3 \cdot 3 = 3^4 = 81$  words in  $\Sigma^4$ , there are  $3 \cdot 3 \cdot 3 \cdot 2 = 27 \cdot 2 = 54$  words that start with one of the letters  $a, b$ , or  $c$  and end with a different letter. Consequently, one must select at least  $54 + 2 = 56$  words from  $\Sigma^4$  to guarantee that at least two start and end with the same letter.

## Section 6.2

1. (a)  $0010101; s_1$                                     (b)  $0000000; s_1$                                     (c)  $001000000; s_0$
2. Because of the first output of 1 we must be at state  $s_2$  when the third input is read. This then forces the first three inputs to be 1,0,1. To get the second output of 1 we must be at state  $s_2$  when the fifth input is read. This forces the remaining two inputs to be 0,1. Hence  $x = 10101$ .
3. (a)  $010110$                                     (b)

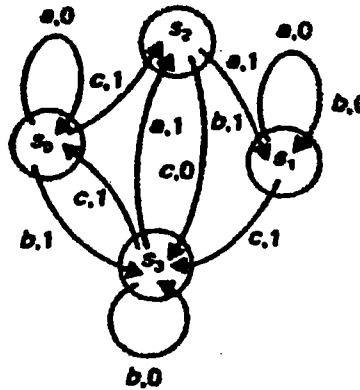

4.  $S = \{s_i | 0 \leq i \leq 5\}$ , where at state  $s_i$ , the machine remembers the insertion of a total of  $5i$  cents.

$I = \{5¢, 10¢, 25¢, B, W\}$

$O = \{n \text{ (nothing)}, P \text{ (peppermint)}, S \text{ (spearmint)}, 5¢, 10¢, 15¢, 20¢, 25¢\}$

	$\nu$					$\omega$				
	5¢	10¢	25¢	B	W	5¢	10¢	25¢	B	W
$s_0$	$s_1$	$s_2$	$s_5$	$s_0$	$s_0$	n	n	n	n	n
$s_1$	$s_2$	$s_3$	$s_5$	$s_1$	$s_1$	n	n	5¢	n	n
$s_2$	$s_3$	$s_4$	$s_5$	$s_2$	$s_2$	n	n	10¢	n	n
$s_3$	$s_4$	$s_5$	$s_5$	$s_3$	$s_3$	n	n	15¢	n	n
$s_4$	$s_5$	$s_5$	$s_5$	$s_4$	$s_4$	n	5¢	20¢	n	n
$s_5$	$s_5$	$s_5$	$s_5$	$s_0$	$s_0$	5¢	10¢	25¢	S	P

5. (a) 010000;  $s_2$       (b)  $(s_1)100000$ ;  $s_2$      $(s_2)000000$ ;  $s_2$      $(s_3)110010$ ;  $s_2$

(c)

	$\nu$		$\omega$	
	0	1	0	1
$s_0$	$s_0$	$s_1$	0	0
$s_1$	$s_1$	$s_2$	1	1
$s_2$	$s_2$	$s_2$	0	0
$s_3$	$s_0$	$s_3$	0	1
$s_4$	$s_2$	$s_3$	0	1

(d)  $s_1$

(e)  $x = 101$  (unique)

6. (a) The machine recognizes (with an output of 1) every 0 (in an input string  $x$ ) that is preceded by another 0.

(b) State  $s_1$  remembers that at least one 0 has been supplied from an input string  $x$ .

(c)  $A = \{1\}^*$ ,  $B = \{00\}$

7. (a) (i) 15

(ii)  $3^{15}$

(iii)  $2^{15}$

(b)  $6^{15}$

8. (a)

Input 0 1 1 0 1 1 1 0 1 1  
 Output 0 0 0 0 0 0 0 0 1 0

(b)

		$\nu$		$\omega$	
		0	1	0	1
$s_0$	$s_0$	$s_1$		0	0
$s_1$	$s_1$	$s_2$		0	0
$s_2$	$s_2$	$s_3$		0	0
$s_3$	$s_3$	$s_4$		0	0
$s_4$	$s_4$	$s_5$		0	0
$s_5$	$s_5$	$s_6$		0	1

(c)  $\omega(x, s_0) = 0000001$  for  $x = (1)1111101; (2)1111011; (3)1110111; (4)1101111; (5)1011111; \text{ and } (6)0111111$

(d) The machine recognizes the occurrence of a sixth 1, a 12th 1, ... in an input  $x$ .

9.

(a)

		$\nu$		$\omega$	
		0	1	0	1
$s_0$	$s_4$	$s_1$		0	0
$s_1$	$s_3$	$s_2$		0	0
$s_2$	$s_3$	$s_2$		0	1
$s_3$	$s_3$	$s_3$		0	0
$s_4$	$s_5$	$s_3$		0	0
$s_5$	$s_5$	$s_3$		1	0

(b) There are only two possibilities:  $x = 1111$  or  $x = 0000$ .

(c)  $A = \{111\}\{1\}^* \cup \{000\}\{0\}^*$

(d) Here  $A = \{11111\}\{1\}^* \cup \{00000\}\{0\}^*$ .

Section 6.3

1. (a)

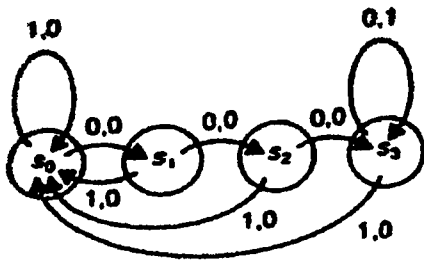

(b)

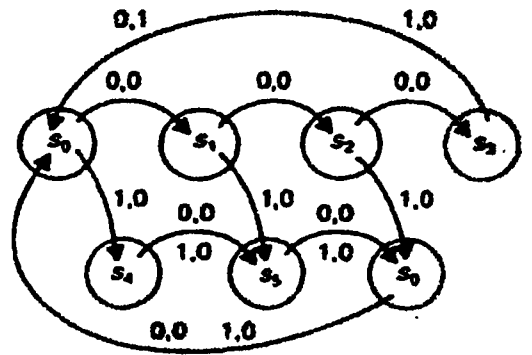

2. (0110)

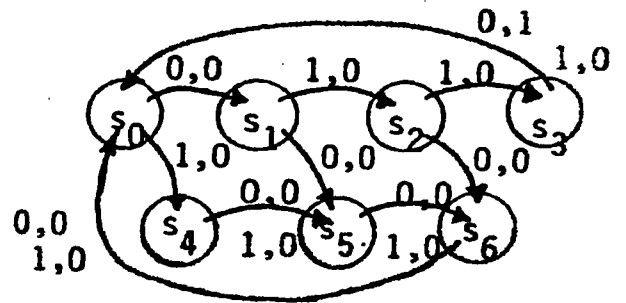
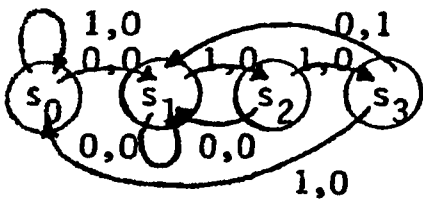

(1010)

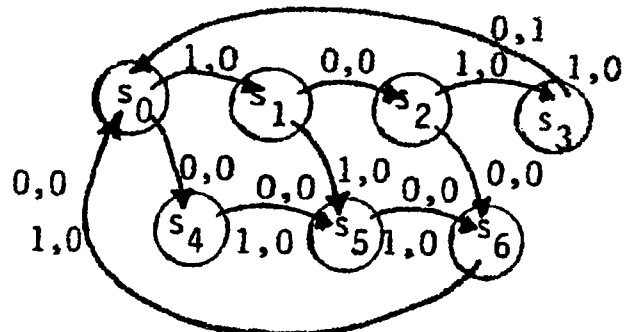
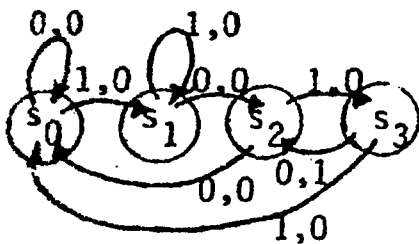

3.

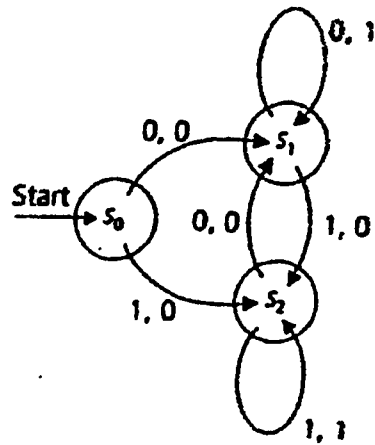

4.

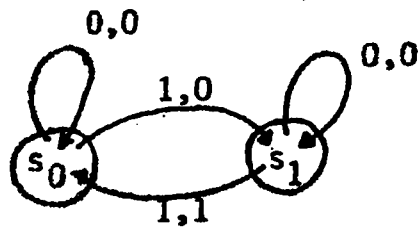

5.

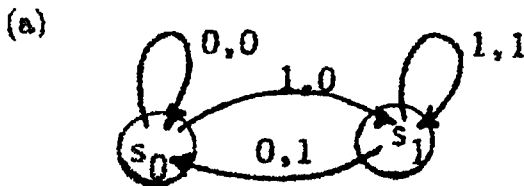

- (b) (i) Input 111  
Output 011  
(ii) Input 1010  
Output 0101  
(iii) Input 00011  
Output 00001

(c) The machine outputs a 0 followed by the first  $n - 1$  symbols of the  $n$  symbol input string  $x$ . Hence the machine is a unit delay.

(d) The machine here performs the same tasks as the one in Fig. 6.13 (and has only two states.)

6. Suppose the contrary and let the machine have  $n$  states, for some  $n \in \mathbb{Z}^+$ . Consider the input string  $0^{n+1}1^n$ . We expect the output here to be  $0^{n+1}1^n$ . As the 0's in this input string are processed we obtain  $n+1$  states  $s_1, s_2, \dots, s_n, s_{n+1}$  from the function  $\nu$ . Consequently, by the Pigeonhole Principle, there are two states  $s_i, s_j$  where  $i < j$  but  $s_i = s_j$ . So if the states  $s_m$ , for  $i+1 \leq m \leq j$ , are removed, along with their inputs of 0, then this machine will recognize the sequence  $0^{n+1-(j-i)}1^n$ , where  $n+1-(j-i) \leq n$ . But the string  $0^{n+1-(j-i)}1^n \notin A$ .
7. (a) The transient states are  $s_0, s_1$ . State  $s_4$  is a sink state.  $\{s_1, s_2, s_3, s_4, s_5\}, \{s_4\}, \{s_2, s_3, s_5\}$  (with the corresponding restrictions on the given function  $\nu$ ) constitute submachines. The strongly connected submachines are  $\{s_4\}$  and  $\{s_2, s_3, s_5\}$ .
- (b) States  $s_2, s_3$  are transient. The only sink state is  $s_4$ . The set  $\{s_0, s_1, s_3, s_4\}$  provides the states for a submachine;  $\{s_0, s_1\}, \{s_4\}$  provide strongly connected submachines.
- (c) Here there are no transient states. State  $s_6$  is a sink state. There are three submachines:  $\{s_2, s_3, s_4, s_5, s_6\}, \{s_3, s_4, s_5, s_6\}$ , and  $\{s_6\}$ . The only strongly connected submachine is  $\{s_6\}$ .
8. Either 110 or 111 provides a transfer sequence from  $s_2$  to  $s_5$ .

### Supplementary Exercises

1. (a) True            (b) False            (c) True  
 (d) True            (e) True            (f) True
2. No. Let  $x \in \Sigma$  with  $A = \{x, xx\}, B = \{x\}$ . Then  $A^* = B^* = \{x^n | n \geq 0\}$ , but  $A \not\subseteq B$ .
3. Let  $x \in \Sigma$  and  $A = \{x\}$ . Then  $A^2 = \{x^2\}$  and  $(A^2)^* = \{\lambda, x^2, x^4, \dots\}$ . However  $A^* = \{\lambda, x, x^2, \dots\}$  and  $(A^*)^2 = A^*$ , so  $(A^*)^2 \neq (A^2)^*$ .
4. (a)  $A^* \subset B^*$ . [For example,  $111 \in B^*$  but  $111 \notin A^*$ .]  
 (b)  $A^* = C^*$ .
5.  $O_{02}$ : Starting at  $s_0$  we can return to  $s_0$  for any input from  $\{1, 00\}^*$ . To finish at state  $s_2$  requires an input of 0. Hence  $O_{02} = \{1, 00\}^* \{0\}$   
 $O_{22}$ :  $\{0\} \{1, 00\}^* \{0\}$   
 $O_{11}$ :  $\emptyset$   
 $O_{00}$ :  $\{1, 00\}^* - \{\lambda\}$   
 $O_{10}$ :  $\{1\} \{1, 00\}^* \cup \{10\} \{1, 00\}^*$

6. (a)

	$\nu$		$\omega$	
	0	1	0	1
$s_0$	$s_0$	$s_1$	0	0
$s_1$	$s_1$	$s_2$	0	0
$s_2$	$s_2$	$s_3$	0	0
$s_3$	$s_3$	$s_0$	0	1

(b) For any input string  $x$ , this machine recognizes (with output 1) the occurrence of every fourth 1 in  $x$ .

(c)  $\binom{8}{8} + \binom{8}{4} + \binom{8}{0} = 72$ . (The first summand is for the sequence of eight 1's, the second summand for the sequences of four 1's and four 0's, and the last summand for the sequence of eight 0's.)

For  $\|x\| = 12$ , there are  $\binom{12}{12} + \binom{12}{8} + \binom{12}{4} + \binom{12}{0} = 992$  such sequences.

7. (a) By the Pigeonhole Principle there is a first state  $s$  that is encountered twice. Let  $y$  be the output string that resulted since  $s$  was first encountered until we reach this state a second time. Then from that point on the output is  $yyy\dots$

(b)  $n$                       (c)  $n$

8.  $x = 110$

9.

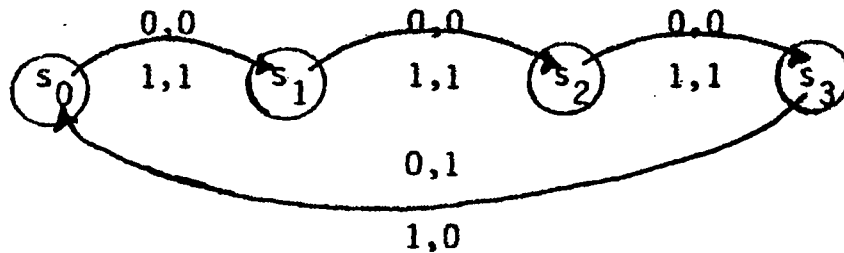

10.

	$\nu$		$\omega$	
	0	1	0	1
$s_0$	$s_1$	$s_2$	0	1
$s_1$	$s_2$	$s_1$	1	0
$s_2$	$s_2$	$s_2$	1	0
$s_3$	$s_1$	$s_0$	0	1

Here the table for  $\omega$  is obtained from Table 6.15 by reversing 0 and 1 (and, 1 and 0) for the columns under 0 and 1.

11.

		$\nu$		$\omega$	
		0	1	0	1
(a)	$(s_0, s_3)$	$(s_0, s_4)$	$(s_1, s_3)$	1	1
	$(s_0, s_4)$	$(s_0, s_3)$	$(s_1, s_4)$	0	1
	$(s_1, s_3)$	$(s_1, s_3)$	$(s_2, s_4)$	1	1
	$(s_1, s_4)$	$(s_1, s_4)$	$(s_2, s_3)$	1	1
	$(s_2, s_3)$	$(s_2, s_3)$	$(s_0, s_4)$	1	1
	$(s_2, s_4)$	$(s_2, s_4)$	$(s_0, s_3)$	1	0

(b)  $\omega((s_0, s_3), 1101) = 1111$ ;  $M_1$  is in state  $s_0$  and  $M_2$  is in state  $s_4$ .

12. The following program determines the output for the input string 1000011000.

```

10  Dim A(3,2), B(3,2)
20  Mat Read A,B
30  Data 2,1,3,1,3,1,0,0,0,0,1,1
40  Dim P(100), S(100)
50  Read N
60  For I = 1 to N
70      Read X
80      If I <> 1 Then 120
90      If X = 0 Then P(1) = B(1,1) Else P(1) = B(1,2)
100     If X = 0 Then S(1) = A(1,1) Else S(1) = A(1,2)
110     Go To 140
120     Y = X + 1
130     P(I) = B(S(I-1)Y) : S(I) = A(S(I-1),Y)
140  Next I
150  Data 10,1,0,0,0,0,1,1,0,0,0
160  Print "The output is";
170  For I = 1 To N-1
180      Print P(I);
190  Next I
200  Print P(N)
210  Print "The machine is now in state"; S(N)
220  End

```

CHAPTER 7  
RELATIONS: THE SECOND TIME AROUND

**Section 7.1**

1. (a)  $\{(1,1),(2,2),(3,3),(4,4),(1,2),(2,1),(2,3),(3,2)\}$   
(b)  $\{(1,1),(2,2),(3,3),(4,4),(1,2)\}$   
(c)  $\{(1,1),(2,2),(1,2),(2,1)\}$
2.  $-9, -2, 5, 12, 19$
3. (a) Let  $f_1, f_2, f_3 \in F$  with  $f_1(n) = n + 1$ ,  $f_2(n) = 5n$ , and  $f_3(n) = 4n + 1/n$ .  
(b) Let  $g_1, g_2, g_3 \in F$  with  $g_1(n) = 3$ ,  $g_2(n) = 1/n$ , and  $f_3(n) = \sin n$ .
4. (a) The relation  $\mathcal{R}$  on the set  $A$  is
  - (i) reflexive if  $\forall x \in A (x, x) \in \mathcal{R}$
  - (ii) symmetric if  $\forall x, y \in A [(x, y) \in \mathcal{R} \implies (y, x) \in \mathcal{R}]$
  - (iii) transitive if  $\forall x, y, z \in A [(x, y), (y, z) \in \mathcal{R} \implies (x, z) \in \mathcal{R}]$
  - (iv) antisymmetric if  $\forall x, y \in A [(x, y), (y, x) \in \mathcal{R} \implies x = y]$ .(b) The relation  $\mathcal{R}$  on the set  $A$  is
  - (i) not reflexive if  $\exists x \in A (x, x) \notin \mathcal{R}$
  - (ii) not symmetric if  $\exists x, y \in A [(x, y) \in \mathcal{R} \wedge (y, x) \notin \mathcal{R}]$
  - (iii) not transitive if  $\exists x, y, z \in A [(x, y), (y, z) \in \mathcal{R} \wedge (x, z) \notin \mathcal{R}]$
  - (iv) not antisymmetric if  $\exists x, y \in A [(x, y), (y, x) \in \mathcal{R} \wedge x \neq y]$ .
5. (a) reflexive, antisymmetric, transitive  
(b) transitive  
(c) reflexive, symmetric, transitive  
(d) symmetric  
(e) (odd): symmetric  
(f) (even): reflexive, symmetric, transitive  
(g) reflexive, symmetric  
(h) reflexive, transitive
6. The relation in part (a) is a partial order. The relations in parts (c) and (f) are equivalence relations.
7. (a) For all  $x \in A, (x, x) \in \mathcal{R}_1, \mathcal{R}_2$ , so  $(x, x) \in \mathcal{R}_1 \cap \mathcal{R}_2$  and  $\mathcal{R}_1 \cap \mathcal{R}_2$  is reflexive.

(b) All of these results are true. For example if  $\mathcal{R}_1, \mathcal{R}_2$  are both transitive and  $(x, y), (y, z) \in \mathcal{R}_1 \cap \mathcal{R}_2$  then  $(x, y), (y, z) \in \mathcal{R}_1, \mathcal{R}_2$ , so  $(x, z) \in \mathcal{R}_1, \mathcal{R}_2$  (transitive property) and  $(x, z) \in \mathcal{R}_1 \cap \mathcal{R}_2$ . [The proofs for the symmetric and antisymmetric properties are similar.]

8. (a) For all  $x \in A, (x, x) \in \mathcal{R}_1, \mathcal{R}_2 \subseteq \mathcal{R}_1 \cup \mathcal{R}_2$ , so if either  $\mathcal{R}_1$  or  $\mathcal{R}_2$  is reflexive, then  $\mathcal{R}_1 \cup \mathcal{R}_2$  is reflexive.

(b) (i) If  $x, y \in A$  and  $(x, y) \in \mathcal{R}_1 \cup \mathcal{R}_2$ , assume without loss of generality, that  $(x, y) \in \mathcal{R}_1$ .  $(x, y) \in \mathcal{R}_1$  and  $\mathcal{R}_1$  symmetric  $\implies (y, x) \in \mathcal{R}_1 \implies (y, x) \in \mathcal{R}_1 \cup \mathcal{R}_2$ , so  $\mathcal{R}_1 \cup \mathcal{R}_2$  is symmetric.

(ii) False: Let  $A = \{1, 2\}, \mathcal{R}_1 = \{(1, 1), (1, 2)\}, \mathcal{R}_2 = \{(2, 1)\}$ . Then  $(1, 2), (2, 1) \in \mathcal{R}_1 \cup \mathcal{R}_2$ , and  $1 \neq 2$ , so  $\mathcal{R}_1 \cup \mathcal{R}_2$  is not antisymmetric.

(iii) False: Let  $A = \{1, 2, 3\}, \mathcal{R}_1 = \{(1, 1), (1, 2)\}, \mathcal{R}_2 = \{(2, 3)\}$ . Then  $(1, 2), (2, 3) \in \mathcal{R}_1 \cup \mathcal{R}_2$ , but  $(1, 3) \notin \mathcal{R}_1 \cup \mathcal{R}_2$ , so  $\mathcal{R}_1 \cup \mathcal{R}_2$  is not transitive.

9.

(a) False: Let  $A = \{1, 2\}$  and  $\mathcal{R} = \{(1, 2), (2, 1)\}$ .

(b) (i) Reflexive: True

(ii) Symmetric: False. Let  $A = \{1, 2\}, \mathcal{R}_1 = \{(1, 1)\}, \mathcal{R}_2 = \{(1, 1), (1, 2)\}$ .

(iii) Antisymmetric & Transitive: False. Let  $A = \{1, 2\}, \mathcal{R}_1 = \{(1, 2)\}, \mathcal{R}_2 = \{(1, 2), (2, 1)\}$ .

(c) (i) Reflexive: False. Let  $A = \{1, 2\}, \mathcal{R}_1 = \{(1, 1)\}, \mathcal{R}_2 = \{(1, 1), (2, 2)\}$ .

(ii) Symmetric: False. Let  $A = \{1, 2\}, \mathcal{R}_1 = \{(1, 2)\}, \mathcal{R}_2 = \{(1, 2), (2, 1)\}$ .

(iii) Antisymmetric: True

(iv) Transitive: False. Let  $A = \{1, 2\}, \mathcal{R}_1 = \{(1, 2), (2, 1)\}, \mathcal{R}_2 = \{(1, 1), (1, 2), (2, 1), (2, 2)\}$ .

(d) True

10.

(a)  $2^{12}$

(b)  $(2^4)(2^6) = 2^{10}$

(c)  $2^6$

(d)  $2^{11}$

(e)  $(2^4)(2^5) = 2^9$

(f)  $2^4 \cdot 3^6$

(g)  $2^4 \cdot 3^5$

(h)  $(2^4)$

(i) 1

11.

(a)  $\binom{2+2-1}{2} \binom{2+2-1}{2} = \binom{3}{2} \binom{3}{2} = 9$

(b)  $\binom{3+2-1}{2} \binom{2+2-1}{2} = \binom{4}{2} \binom{3}{2} = 18$

(c)  $\binom{4+2-1}{2} \binom{2+2-1}{2} = \binom{5}{2} \binom{3}{2} = 30$

(d)  $\binom{4+2-1}{2} \binom{3+2-1}{2} = \binom{5}{2} \binom{4}{2} = 60$

(e)  $\binom{2+2-1}{2}^4 = \binom{3}{2}^4 = 3^4 = 81$

(f) Since  $13,860 = 2^2 \cdot 3^2 \cdot 5 \cdot 7 \cdot 11$ , it follows that  $\mathcal{R}$  contains  $\binom{3+2-1}{2}^2 \binom{2+2-1}{2}^3 = \binom{4}{2}^2 \binom{3}{2}^3 = (36)(27) = 972$  ordered pairs.

12.

$$\begin{aligned} \text{Since } 5880 &= \binom{6+2-1}{2} \binom{4+2-1}{2} \binom{(k+1)+2-1}{2} \\ &= \binom{7}{2} \binom{5}{2} \binom{k+2}{2} = (21)(10)\left(\frac{1}{2}\right)(k+2)(k+1), \end{aligned}$$

we find that  $56 = (k+2)(k+1)$  and  $k = 6$ .

For  $n = p_1^5 p_2^3 p_3^6$  there are  $(5+1)(3+1)(6+1) = (6)(4)(7) = 168$  positive integer divisors, so  $|A| = 168$ .

13. There may exist an element  $a \in A$  such that for all  $b \in B$  neither  $(a, b)$  nor  $(b, a) \in \mathcal{R}$ .

14. There are  $n$  ordered pairs of the form  $(x, x)$ ,  $x \in A$ . For each of the  $(n^2 - n)/2$  sets  $\{(x, y), (y, x)\}$  of ordered pairs where  $x, y \in A$ ,  $x \neq y$ , one element is chosen. This results in a maximum value of  $n + (n^2 - n)/2 = (n^2 + n)/2$ .

The number of antisymmetric relations that can have this size is  $2^{(n^2-n)/2}$ .

15.  $r - n$  counts the elements in  $\mathcal{R}$  of the form  $(a, b)$ ,  $a \neq b$ . Since  $\mathcal{R}$  is symmetric,  $r - n$  is even.

16. (a)  $x\mathcal{R}y$  if  $x < y$ .

(b) For example, suppose that  $\mathcal{R}$  satisfies conditions (ii) and (iii). Since  $\mathcal{R} \neq \emptyset$ , let  $(x, y) \in \mathcal{R}$ , for  $x, y \in A$ . Since  $\mathcal{R}$  is symmetric, it follows that  $(y, x) \in \mathcal{R}$ . Then by the transitive property we have  $(x, x) \in \mathcal{R}$  (and  $(y, y) \in \mathcal{R}$ ). But if  $(x, x) \in \mathcal{R}$  the relation  $\mathcal{R}$  is *not* irreflexive.

(c)  $2^{(n^2-n)}$ ;  $2^{n^2} - 2(2^{(n^2-n)})$

17. (a)  $\binom{7}{5} \binom{21}{0} + \binom{7}{3} \binom{21}{1} + \binom{7}{1} \binom{21}{2}$

(b)  $\binom{7}{5} \binom{21}{0} + \binom{7}{3} \binom{21}{1} + \binom{7}{1} \binom{21}{2}$

18. (a) Let  $A_1 = f^{-1}(x)$ ,  $A_2 = f^{-1}(y)$ , and  $A_3 = f^{-1}(z)$ . Then  $\mathcal{R} = (A_1 \times A_1) \cup (A_2 \times A_2) \cup (A_3 \times A_3)$ , so  $|\mathcal{R}| = 10^2 + 10^2 + 5^2 = 225$ .

(b)  $n_1^2 + n_2^2 + n_3^2 + n_4^2$

## Section 7.2

1.  $\mathcal{R} \circ \mathcal{S} = \{(1, 3), (1, 4)\}$ ;  $\mathcal{S} \circ \mathcal{R} = \{(1, 2), (1, 3), (1, 4), (2, 4)\}$ ;

$\mathcal{R}^2 = \mathcal{R}^3 = \{(1, 4), (2, 4), (4, 4)\}$ ;

$\mathcal{S}^2 = \mathcal{S}^3 = \{(1, 1), (1, 2), (1, 3), (1, 4)\}$ .

2. Let  $x \in A$ .  $\mathcal{R}$  reflexive  $\implies (x, x) \in \mathcal{R}$ .  $(x, x) \in \mathcal{R}, (x, x) \in \mathcal{R} \implies (x, x) \in \mathcal{R} \circ \mathcal{R} = \mathcal{R}^2$ .

3.  $(a, d) \in (\mathcal{R}_1 \circ \mathcal{R}_2) \circ \mathcal{R}_3 \implies (a, c) \in \mathcal{R}_1 \circ \mathcal{R}_2, (c, d) \in \mathcal{R}_3$  for some  $c \in C \implies (a, b) \in \mathcal{R}_1, (b, c) \in \mathcal{R}_2, (c, d) \in \mathcal{R}_3$  for some  $b \in B, c \in C \implies (a, b) \in \mathcal{R}_1, (b, d) \in \mathcal{R}_2 \circ \mathcal{R}_3 \implies (a, d) \in \mathcal{R}_1 \circ (\mathcal{R}_2 \circ \mathcal{R}_3)$ , and  $(\mathcal{R}_1 \circ \mathcal{R}_2) \circ \mathcal{R}_3 \subseteq \mathcal{R}_1 \circ (\mathcal{R}_2 \circ \mathcal{R}_3)$ .

4. (a)  $\mathcal{R}_1 \circ (\mathcal{R}_2 \cup \mathcal{R}_3) = \mathcal{R}_1 \circ \{(w, 4), (w, 5), (x, 6), (y, 4), (y, 5), (y, 6)\}$   
 $= \{(1, 4), (1, 5), (3, 4), (3, 5), (2, 6), (1, 6)\}$   
 $(\mathcal{R}_1 \circ \mathcal{R}_2) \cup (\mathcal{R}_1 \circ \mathcal{R}_3)$   
 $= \{(1, 5), (3, 5), (2, 6), (1, 4), (1, 6)\} \cup \{(1, 4), (1, 5), (3, 4), (3, 5)\}$   
 $= \{(1, 4), (1, 5), (1, 6), (2, 6), (3, 4), (3, 5)\}$
- (b)  $\mathcal{R}_1 \circ (\mathcal{R}_2 \cap \mathcal{R}_3) = \mathcal{R}_1 \circ \{(w, 5)\} = \{(1, 5), (3, 5)\}$   
 $(\mathcal{R}_1 \circ \mathcal{R}_2) \cap (\mathcal{R}_1 \circ \mathcal{R}_3) = \{(1, 5), (3, 5), (2, 6), (1, 4), (1, 6)\} \cap \{(1, 4), (1, 5), (3, 4), (3, 5)\} =$   
 $\{(1, 4), (1, 5), (3, 5)\}.$
5.  $\mathcal{R}_1 \circ (\mathcal{R}_2 \cap \mathcal{R}_3) = \mathcal{R}_2 \circ \{(m, 3), (m, 4)\} = \{(1, 3), (1, 4)\}$   
 $(\mathcal{R}_1 \circ \mathcal{R}_2) \cap (\mathcal{R}_1 \circ \mathcal{R}_3) = \{(1, 3), (1, 4)\} \cap \{(1, 3), (1, 4)\} = \{(1, 3), (1, 4)\}.$
6. (a)  $(x, z) \in \mathcal{R}_1 \circ (\mathcal{R}_2 \cup \mathcal{R}_3) \iff$  for some  $y \in B, (x, y) \in \mathcal{R}_1, (y, z) \in \mathcal{R}_2 \cup \mathcal{R}_3 \iff$  for  
some  $y \in B, ((x, y) \in \mathcal{R}_1, (y, z) \in \mathcal{R}_2)$  or  $((x, y) \in \mathcal{R}_1, (y, z) \in \mathcal{R}_3) \implies (x, z) \in \mathcal{R}_1 \circ \mathcal{R}_2$  or  
 $(x, z) \in \mathcal{R}_1 \circ \mathcal{R}_3 \iff (x, z) \in (\mathcal{R}_1 \circ \mathcal{R}_2) \cup (\mathcal{R}_1 \circ \mathcal{R}_3)$ , so  $\mathcal{R}_1 \circ (\mathcal{R}_2 \cup \mathcal{R}_3) \subseteq (\mathcal{R}_1 \circ \mathcal{R}_2) \cup (\mathcal{R}_1 \circ \mathcal{R}_3)$ .  
For the opposite inclusion,  $(x, z) \in (\mathcal{R}_1 \circ \mathcal{R}_2) \cup (\mathcal{R}_1 \circ \mathcal{R}_3) \implies (x, z) \in \mathcal{R}_1 \circ \mathcal{R}_2$  or  $(x, z) \in$   
 $\mathcal{R}_1 \circ \mathcal{R}_3$ . Assume without loss of generality that  $(x, z) \in \mathcal{R}_1 \circ \mathcal{R}_2$ . Then there exists an  
element  $y \in B$  so that  $(x, y) \in \mathcal{R}_1$  and  $(y, z) \in \mathcal{R}_2$ . But  $(y, z) \in \mathcal{R}_2 \implies (y, z) \in \mathcal{R}_2 \cup \mathcal{R}_3$ ,  
so  $(x, z) \in \mathcal{R}_1 \circ (\mathcal{R}_2 \cup \mathcal{R}_3)$ , and the result follows.
- (b) The proof here is similar to that in part (a). To show that the inclusion can be  
proper, let  $A = B = C = \{1, 2, 3\}$  with  $\mathcal{R}_1 = \{(1, 2), (1, 1)\}, \mathcal{R}_2 = \{(2, 3)\}, \mathcal{R}_3 = \{(1, 3)\}$ .  
Then  $\mathcal{R}_1 \circ (\mathcal{R}_2 \cup \mathcal{R}_3) = \mathcal{R}_1 \circ \emptyset = \emptyset$ , but  $(\mathcal{R}_1 \circ \mathcal{R}_2) \cup (\mathcal{R}_1 \circ \mathcal{R}_3) = \{(1, 3)\}.$
7. This follows by the Pigeonhole Principle. Here the pigeons are the  $2^{n^2} + 1$  integers between  
0 and  $2^{n^2}$ , inclusive, and the pigeonholes are the  $2^{n^2}$  relations on  $A$ .
8. Let  $S = \{(1, 1), (1, 2), (1, 4)\}$  and  $T = \{(2, 1), (2, 2), (1, 4)\}.$
9. Here there are two choices for each  $a_{ii}, 1 \leq i < 6$ . For each pair  $a_{ij}, a_{ji}, 1 \leq i < j \leq 6$ ,  
there are two choices, and there are  $(36 - 6)/2 = 15$  such pairs. Consequently there are  
 $(2^6)(2^{15}) = 2^{21}$  such matrices.
10. For each 0 in  $E$  the matrix  $F$  can have either 0 or 1 (the other entries in  $F$  are 1). Since  
there are seven 0's in  $E$  there are  $2^7$  possible matrices  $F$ . There are  $2^5$  possible matrices  $G$ .
11. Consider the entry in the  $i$ -th row and  $j$ -th column of  $M(\mathcal{R}_1 \circ \mathcal{R}_2)$ . If this entry is a 1 then  
there exists  $b_k \in B$  where  $1 \leq k \leq n$  and  $(a_i, b_k) \in \mathcal{R}_1, (b_k, c_j) \in \mathcal{R}_2$ . Consequently, the  
entry in the  $i$ -th row and  $k$ -th column of  $M(\mathcal{R}_1)$  is 1 and the entry in the  $k$ -th row and  
 $j$ -th column of  $M(\mathcal{R}_2)$  is 1. This results in a 1 in the  $i$ -th row and  $j$ -th column in the  
product  $M(\mathcal{R}_1) \cdot M(\mathcal{R}_2)$ .
- Should the entry in row  $i$  and column  $j$  of  $M(\mathcal{R}_1 \circ \mathcal{R}_2)$  be 0, then for each  $b_k, 1 \leq k \leq n$ ,  
either  $(a_i, b_k) \notin \mathcal{R}_1$  or  $(b_k, c_j) \notin \mathcal{R}_2$ . This means that in the matrices  $M(\mathcal{R}_1), M(\mathcal{R}_2)$ , if the  
entry in the  $i$ -th row and  $k$ -th column of  $M(\mathcal{R}_1)$  is 1 then the entry in the  $k$ -th row and  $j$ -th

column of  $M(\mathcal{R}_2)$  is 0. Hence the entry in the  $i$ -th row and  $j$ -th column of  $M(\mathcal{R}_1) \cdot M(\mathcal{R}_2)$  is 0.

12. (a) If  $M(\mathcal{R}) = \mathbf{0}$ , then  $\forall x, y \in A (x, y) \notin \mathcal{R}$ . Hence  $\mathcal{R} = \emptyset$ . Conversely, if  $M(\mathcal{R}) \neq \mathbf{0}$ , then  $\exists x, y \in A$  where  $x\mathcal{R}y$ . Hence  $(x, y) \in \mathcal{R}$  and  $\mathcal{R} \neq \emptyset$ .

(c) For  $m = 1$ , we have  $M(\mathcal{R}^1) = M(\mathcal{R}) = [M(\mathcal{R})]^1$ , so the result is true in this case. Assuming the truth of the statement for  $m = k$  we have  $M(\mathcal{R}^k) = [M(\mathcal{R})]^k$ . Now consider  $m = k + 1$ .  $M(\mathcal{R}^{k+1}) = M(\mathcal{R} \circ \mathcal{R}^k) = M(\mathcal{R}) \cdot M(\mathcal{R}^k)$  (from Exercise 11)  $= M(\mathcal{R}) \cdot [M(\mathcal{R})]^k = [M(\mathcal{R})]^{k+1}$ . Consequently this result is true for all  $m \geq 1$  by the Principle of Mathematical Induction.

13. (a)  $\mathcal{R}$  reflexive  $\iff (x, x) \in \mathcal{R}$ , for all  $x \in A \iff m_{xx} = 1$  in  $M = (m_{ij})_{n \times n}$ , for all  $x \in A \iff I_n \leq M$ .

(b)  $\mathcal{R}$  symmetric  $\iff [\forall x, y \in A (x, y) \in \mathcal{R} \implies (y, x) \in \mathcal{R}] \iff [\forall x, y \in A m_{xy} = 1$  in  $M \implies m_{yx} = 1$  in  $M] \iff M = M^{tr}$ .

14.

```
10! THIS PROGRAM MAY BE USED TO DETERMINE IF A RELATION
20! ON A SET OF SIZE N, WHERE  $N \leq 20$ , IS AN
30! EQUIVALENCE RELATION. WE ASSUME WITHOUT LOSS OF
40! GENERALITY THAT THE ELEMENTS ARE 1,2,3,...,N.
50!
60 INPUT "N ="; N
70 PRINT " INPUT THE RELATION MATRIX FOR THE RELATION"
80 PRINT "BEING EXAMINED BY TYPING  $A(I,J) = 1$  FOR EACH"
90 PRINT " $1 \leq I \leq N, 1 \leq J \leq N$ , WHERE (I,J) IS IN"
100 PRINT "THE RELATION. WHEN ALL THE ORDERED PAIRS HAVE"
110 PRINT "BEEN ENTERED TYPE 'CONT' "
120 STOP
130 DIM A(20,20), C(20,20), D(20,20)
140 FOR K = 1 TO N
150     T = T + A(K,K)
160 NEXT K
170 IF T = N THEN &
        PRINT "R IS REFLEXIVE"; X = 1: GO TO 190
180 PRINT "R IS NOT REFLEXIVE"
190 FOR I = 1 TO N
200     FOR J = I + 1 TO N
210         IF  $A(I,J) \neq A(J,I)$  THEN GO TO 260
220     NEXT J
230 NEXT I
240 PRINT "R IS SYMMETRIC": Y = 1
250 GO TO 270
260 PRINT "R IS NOT SYMMETRIC"
270 MAT C = A
280 MAT D = A*C
290 FOR I = 1 TO N
300     FOR J = 1 TO N
310         IF  $D(I,J) > 0$  AND  $A(I,J) = 0$  THEN GO TO 360
320     NEXT J
330 NEXT I
340 PRINT "R IS TRANSITIVE"; Z = 1
350 GO TO 370
360 PRINT "R IS NOT TRANSITIVE"
370 IF X + Y + Z = 3 THEN &
        PRINT "R IS AN EQUIVALENCE RELATION" &
        ELSE PRINT "R IS NOT AN EQUIVALENCE RELATION"
380 END
```

15. (a)

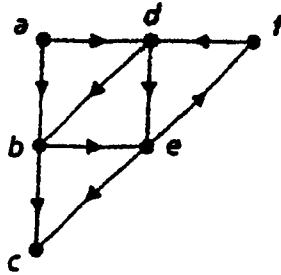

(b)

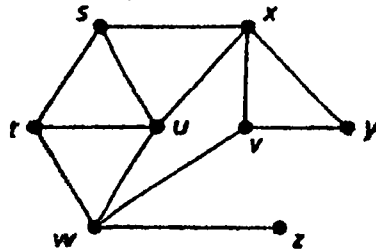

16. (a) True                      (b) True                      (c) True                      (d) False

17. (i)  $\mathcal{R} = \{(a, b), (b, a), (a, e), (e, a), (b, c), (c, b), (b, d), (d, b), (b, e), (e, b), (d, e), (e, d), (d, f), (f, d)\}$

$$M(\mathcal{R}) = \begin{matrix} & \begin{matrix} (a) & (b) & (c) & (d) & (e) & (f) \end{matrix} \\ \begin{matrix} (a) \\ (b) \\ (c) \\ (d) \\ (e) \\ (f) \end{matrix} & \begin{bmatrix} 0 & 1 & 0 & 0 & 1 & 0 \\ 1 & 0 & 1 & 1 & 1 & 0 \\ 0 & 1 & 0 & 0 & 0 & 0 \\ 0 & 1 & 0 & 0 & 1 & 1 \\ 1 & 1 & 0 & 1 & 0 & 0 \\ 0 & 0 & 0 & 1 & 0 & 0 \end{bmatrix} \end{matrix}$$

For parts (ii), (iii), and (iv), the rows and columns of the relation matrix are indexed as

in part (i).

(ii)  $\mathcal{R} = \{(a, b), (b, e), (d, b), (d, c), (e, f)\}$

$$M(\mathcal{R}) = \begin{bmatrix} 0 & 1 & 0 & 0 & 0 & 0 \\ 0 & 0 & 0 & 0 & 1 & 0 \\ 0 & 0 & 0 & 0 & 0 & 0 \\ 0 & 1 & 1 & 0 & 0 & 0 \\ 0 & 0 & 0 & 0 & 0 & 0 \\ 0 & 0 & 0 & 0 & 0 & 0 \end{bmatrix}$$

(iii)  $\mathcal{R} = \{(a, a), (a, b), (b, a), (c, d), (d, c), (d, e), (e, d), (d, f), (f, d), (e, f), (f, e)\}$

$$M(\mathcal{R}) = \begin{bmatrix} 1 & 1 & 0 & 0 & 0 & 0 \\ 1 & 0 & 0 & 0 & 0 & 0 \\ 0 & 0 & 0 & 1 & 0 & 0 \\ 0 & 0 & 1 & 0 & 1 & 1 \\ 0 & 0 & 0 & 1 & 0 & 1 \\ 0 & 0 & 0 & 1 & 1 & 0 \end{bmatrix}$$

(iv)  $\mathcal{R} = \{(b, a), (b, c), (c, b), (b, e), (c, d), (e, d)\}$

$$M(\mathcal{R}) = \begin{bmatrix} 0 & 0 & 0 & 0 & 0 & 0 \\ 1 & 0 & 1 & 0 & 1 & 0 \\ 0 & 1 & 0 & 1 & 0 & 0 \\ 0 & 0 & 0 & 0 & 0 & 0 \\ 0 & 0 & 0 & 1 & 0 & 0 \\ 0 & 0 & 0 & 0 & 0 & 0 \end{bmatrix}$$

18. (a)  $\mathcal{R} = \{(v, w), (v, x), (w, v), (w, x), (w, y), (w, z), (x, z), (y, z)\}$

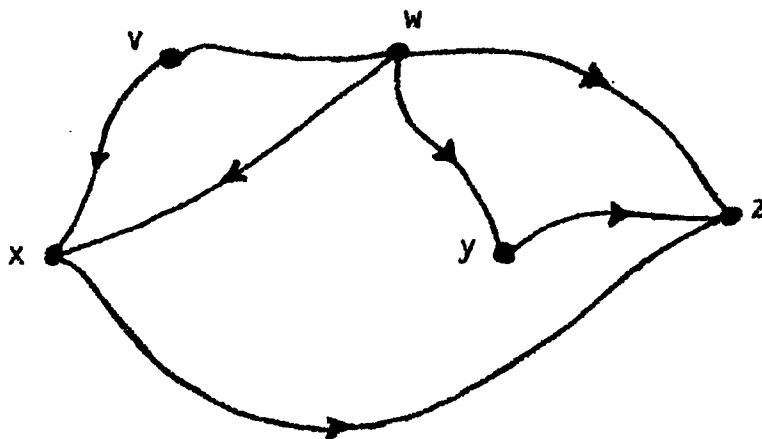

(b)  $\mathcal{R} = \{(v, w), (v, x), (v, y), (w, v), (w, x), (x, v), (x, w), (x, z), (y, v), (y, z), (z, x), (z, y)\}$

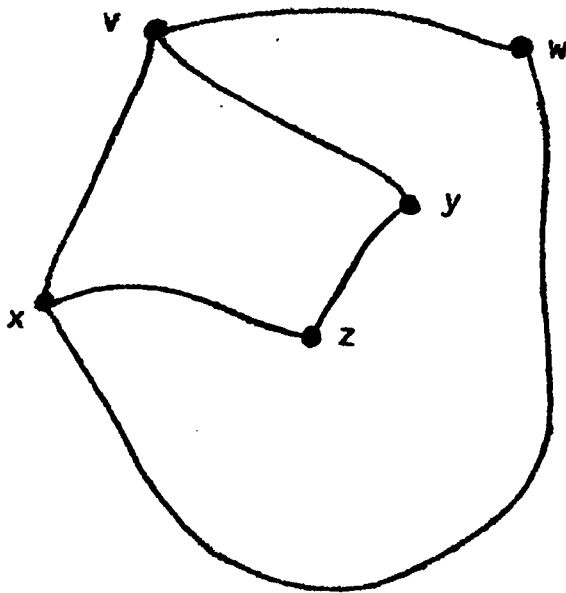

19.  $\mathcal{R}$ :

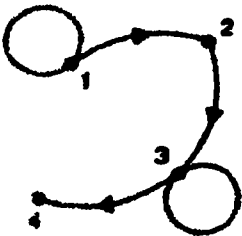

$\mathcal{R}^2$ :

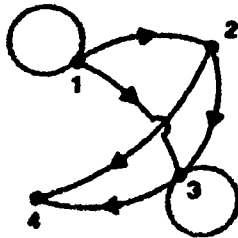

$\mathcal{R}^3$  and  $\mathcal{R}^4$ :

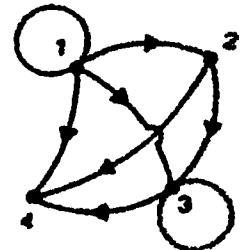

20. (a) (i)  $\binom{7}{2}$   
 (ii) Each directed path corresponds to a subset of  $\{2, 3, 4, 5, 6\}$ . There are  $2^5$  subsets of  $\{2, 3, 4, 5, 6\}$  and, consequently,  $2^5$  directed paths in  $G$  from 1 to 7.  
 (b) (i)  $\binom{n}{2} = |E|$ .  
 (ii) There are  $2^{n-2}$  directed paths in  $G$  from 1 to  $n$ .  
 (iii) There are  $2^{[(b-a)+1]-2} = 2^{b-a-1}$  directed paths in  $G$  from  $a$  to  $b$ .

21.  $2^{25}; (2^5)(2^{10}) = 2^{15}$

22.  $2^{25}; (2^5)(2^{10}) = 2^{15}$

23. (a)  $\mathcal{R}_1 :$

$$\begin{bmatrix} 1 & 1 & 0 & 0 & 0 \\ 1 & 1 & 0 & 0 & 0 \\ 0 & 0 & 1 & 1 & 0 \\ 0 & 0 & 1 & 1 & 0 \\ 0 & 0 & 0 & 0 & 1 \end{bmatrix}$$

$\mathcal{R}_2 :$

$$\begin{bmatrix} 1 & 1 & 1 & 0 & 0 \\ 1 & 1 & 1 & 0 & 0 \\ 1 & 1 & 1 & 0 & 0 \\ 0 & 0 & 0 & 1 & 1 \\ 0 & 0 & 0 & 1 & 1 \end{bmatrix}$$

(b) Given an equivalence relation  $\mathcal{R}$  on a finite set  $A$ , list the elements of  $A$  so that elements in the same cell of the partition (See Section 7.4.) are adjacent. The resulting relation matrix will then have square blocks of 1's along the diagonal (from upper left to lower right).

24.  $\begin{pmatrix} 6 \\ 2 \end{pmatrix}; \begin{pmatrix} 7 \\ 2 \end{pmatrix}; \begin{pmatrix} n \\ 2 \end{pmatrix}$

25.

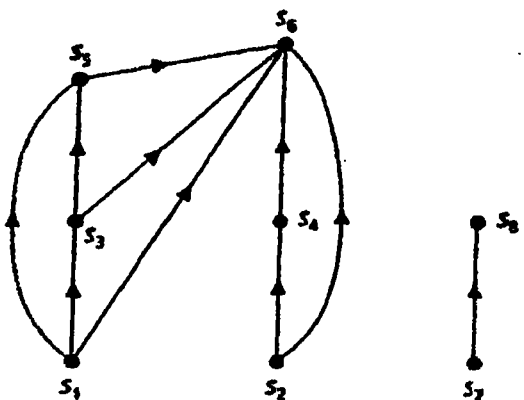

26. (a) Let  $k \in \mathbb{Z}^+$ . Then  $\mathcal{R}^{12k} = \{(1, 1), (2, 2), (3, 3), (4, 4), (5, 5), (6, 6), (7, 7)\}$  and  $\mathcal{R}^{12k+1} = \mathcal{R}$ . The smallest value of  $n > 1$  such that  $\mathcal{R}^n = \mathcal{R}$  is  $n = 13$ . For all multiples of 12 the graph consists of all loops. When  $n = 3$ ,  $(5, 5), (6, 6), (7, 7) \in \mathcal{R}^3$ , and this is the smallest power of  $\mathcal{R}$  that contains at least one loop.

(b) When  $n = 2$ , we find  $(1, 1), (2, 2)$  in  $\mathcal{R}$ . For all  $k \in \mathbb{Z}^+$ ,  $\mathcal{R}^{30k} = \{(x, x) | x \in \mathbb{Z}^+, 1 \leq x \leq 10\}$  and  $\mathcal{R}^{30k+1} = \mathcal{R}$ . Hence  $\mathcal{R}^{31}$  is the smallest power of  $\mathcal{R}$  (for  $n > 1$ ) where  $\mathcal{R}^n = \mathcal{R}$ .

(c) Let  $\mathcal{R}$  be a relation on set  $A$  where  $|A| = m$ . Let  $G$  be the directed graph associated with  $\mathcal{R}$  - each component of  $G$  is a directed cycle  $C_i$  on  $m_i$  vertices, with  $1 \leq i \leq k$ . (Thus  $m_1 + m_2 + \dots + m_k = m$ .) The smallest power of  $\mathcal{R}$  where loops appear is  $\mathcal{R}^t$ , for  $t = \min\{m_i | 1 \leq i \leq k\}$ .

Let  $s = \text{lcm}(m_1, m_2, \dots, m_k)$ . Then  $\mathcal{R}^{rs} =$  the identity (equality) relation on  $A$  and  $\mathcal{R}^{rs+1} = \mathcal{R}$ , for all  $r \in \mathbb{Z}^+$ . The smallest power of  $\mathcal{R}$  that reproduces  $\mathcal{R}$  is  $s + 1$ .

27.  $\binom{n}{2} = 703 \Rightarrow n = 38$

### Section 7.3

1.

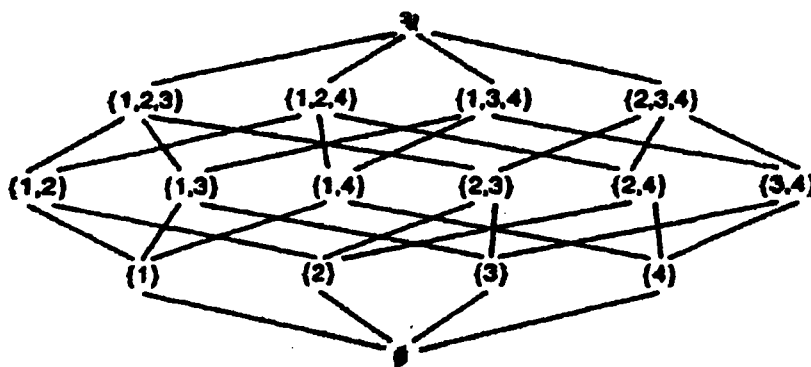

2.

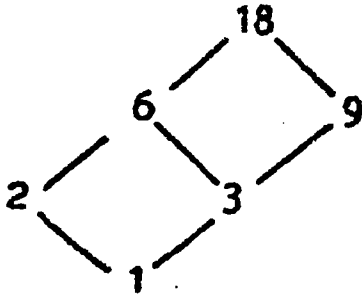

3. For all  $a \in A, b \in B, a\mathcal{R}_1a$  and  $b\mathcal{R}_2b$  so  $(a, b)\mathcal{R}(a, b)$ , and  $\mathcal{R}$  is reflexive. Next  $(a, b)\mathcal{R}(c, d), (c, d)\mathcal{R}(a, b) \implies a\mathcal{R}_1c, c\mathcal{R}_1a$  and  $b\mathcal{R}_2d, d\mathcal{R}_2b \implies a = c, b = d \implies (a, b) = (c, d)$ , so  $\mathcal{R}$  is antisymmetric. Finally,  $(a, b)\mathcal{R}(c, d), (c, d)\mathcal{R}(e, f) \implies a\mathcal{R}_1c, c\mathcal{R}_1e$  and  $b\mathcal{R}_2d, d\mathcal{R}_2f \implies a\mathcal{R}_1e, b\mathcal{R}_2f \implies (a, b)\mathcal{R}(e, f)$ , and  $\mathcal{R}$  is transitive. Consequently,  $\mathcal{R}$  is a partial order.
4. No. Let  $A = B = \{1, 2\}$  with each of  $\mathcal{R}_1, \mathcal{R}_2$  the usual "is less than or equal to" relation. Then  $\mathcal{R}$  is a partial order but it is not a total order for we cannot compare  $(1, 2)$  and  $(2, 1)$ .
5.  $\emptyset < \{1\} < \{2\} < \{3\} < \{1, 2\} < \{1, 3\} < \{2, 3\} < \{1, 2, 3\}$ . (There are other possibilities.)

6. (a)

	(a)	(b)	(c)	(d)	(e)
(a)	1	1	1	1	1
(b)	0	1	0	1	1
(c)	0	0	1	1	1
(d)	0	0	0	1	1
(e)	0	0	0	0	1

$M(\mathcal{R}) = \begin{bmatrix} 1 & 1 & 1 & 1 & 1 \\ 0 & 1 & 0 & 1 & 1 \\ 0 & 0 & 1 & 1 & 1 \\ 0 & 0 & 0 & 1 & 1 \\ 0 & 0 & 0 & 0 & 1 \end{bmatrix}$

(b)

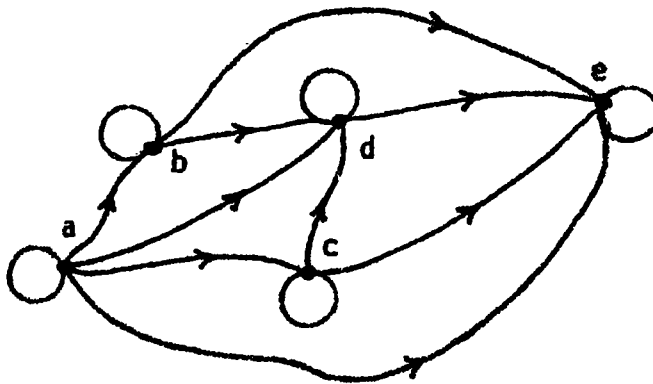

(c)  $a < b < c < d < e$  or  $a < c < b < d < e$

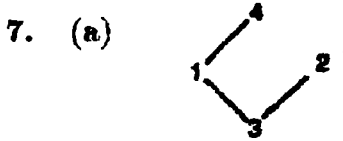

(b)  $3 < 2 < 1 < 4$  or  $3 < 1 < 2 < 4$ .

(c) 2

8. Suppose that  $x, y \in A$  and that both are least elements. Then  $x \mathcal{R} y$  since  $x$  is a least element, and  $y \mathcal{R} x$  since  $y$  is a least element. With  $\mathcal{R}$  antisymmetric we have  $x = y$ .
9. Let  $x, y$  both be greatest lower bounds. Then  $x \mathcal{R} y$  since  $x$  is a lower bound and  $y$  is a greatest lower bound. By similar reasoning  $y \mathcal{R} x$ . Since  $\mathcal{R}$  is antisymmetric,  $x = y$ . [The proof for the *lub* is similar.]
10. Let  $\mathcal{U} = \{1, 2, 3, 4\}$ . Let  $A$  be the collection of all proper subsets of  $\mathcal{U}$ , partially ordered under set inclusion. Then  $\{1, 2, 3\}$ ,  $\{1, 2, 4\}$ ,  $\{1, 3, 4\}$ , and  $\{2, 3, 4\}$  are all maximal elements.
11. Let  $\mathcal{U} = \{1, 2\}$ ,  $A = \mathcal{P}(\mathcal{U})$ , and  $\mathcal{R}$  the inclusion relation. Then  $(A, \mathcal{R})$  is a poset but not a total order. Let  $B = \{\emptyset, \{1\}\}$ . Then  $(B \times B) \cap \mathcal{R}$  is a total order.
12. For all vertices  $x, y \in A$ ,  $x \neq y$ , there is either an edge  $(x, y)$  or an edge  $(y, x)$ , but not both. In addition, if  $(x, y), (y, z)$  are edges in  $G$  then  $(x, z)$  is an edge in  $G$ . Finally, at every vertex of the graph there is a loop.
13.  $n + \binom{n}{2}$
14.  $n + \binom{n}{2}$
15. (a) The  $n$  elements of  $A$  are arranged along a vertical line. For if  $A = \{a_1, a_2, \dots, a_n\}$ , where  $a_1 \mathcal{R} a_2 \mathcal{R} a_3 \mathcal{R} \dots \mathcal{R} a_n$ , then the diagram can be drawn as



(b)  $n!$

16. (a) Let  $a \in A$  with  $a$  minimal. Then for  $x \in A$ ,  $x\mathcal{R}a \implies x = a$ . So if  $M(\mathcal{R})$  is the relation matrix for  $\mathcal{R}$ , the column under ' $a$ ' has all 0's except for the one 1 for the ordered pair  $(a, a)$ .

(b) Let  $b \in A$ , with  $b$  a greatest element. Then the column under ' $b$ ' in  $M(\mathcal{R})$  has all 1's. If  $c \in A$  and  $c$  is a least element, then the row of  $M(\mathcal{R})$  determined by ' $c$ ' has all 1's.

17.

	$lub$	$glb$		$lub$	$glb$		$lub$	$glb$
(a)	$\{1,2\}$	$\emptyset$	(c)	$\{1,2\}$	$\emptyset$	(e)	$\{1,2,3\}$	$\emptyset$
(b)	$\{1,2,3\}$	$\emptyset$	(d)	$\{1,2,3\}$	$\{1\}$			

18. (a) (i) Only one such upper bound -  $\{1,2,3\}$ . (ii) Here the upper bound has the form  $\{1,2,3,x\}$  where  $x \in \mathcal{U}$  and  $4 \leq x \leq 7$ . Hence there are four such upper bounds. (iii) There are  $\binom{4}{2}$  upper bounds of  $B$  that contain five elements from  $\mathcal{U}$ .

(b)  $\binom{4}{0} + \binom{4}{1} + \binom{4}{2} + \binom{4}{3} + \binom{4}{4} = 2^4 = 16$

(c)  $lub B = \{1,2,3\}$

(d) One - namely  $\emptyset$

(e)  $glb B = \emptyset$

19. For each  $a \in \mathbb{Z}$  it follows that  $a\mathcal{R}a$  because  $a - a = 0$ , an even nonnegative integer. Hence  $\mathcal{R}$  is reflexive. If  $a, b, c \in \mathbb{Z}$  with  $a\mathcal{R}b$  and  $b\mathcal{R}c$  then

$$a - b = 2m, \text{ for some } m \in \mathbb{N}$$

$$b - c = 2n, \text{ for some } n \in \mathbb{N},$$

and  $a - c = (a - b) + (b - c) = 2(m + n)$ , where  $m + n \in \mathbb{N}$ . Therefore,  $a\mathcal{R}c$  and  $\mathcal{R}$  is transitive. Finally, suppose that  $a\mathcal{R}b$  and  $b\mathcal{R}a$  for some  $a, b \in \mathbb{Z}$ . Then  $a - b$  and  $b - a$  are both nonnegative integers. Since this can only occur for  $a - b = b - a$ , we find that  $[a\mathcal{R}b \wedge b\mathcal{R}a] \implies a = b$ , so  $\mathcal{R}$  is antisymmetric.

Consequently, the relation  $\mathcal{R}$  is a partial order for  $\mathbb{Z}$ . But it is *not* a total order. For example,  $2, 3 \in \mathbb{Z}$  and we have neither  $2\mathcal{R}3$  nor  $3\mathcal{R}2$ , because neither  $-1$  nor  $1$ , respectively, is a nonnegative even integer.

20. (a) For all  $(a, b) \in A$ ,  $a = a$  and  $b \leq b$ , so  $(a, b)\mathcal{R}(a, b)$  and the relation is reflexive. If  $(a, b), (c, d) \in A$  with  $(a, b)\mathcal{R}(c, d)$  and  $(c, d)\mathcal{R}(a, b)$ , then if  $a \neq c$  we find that

$$(a, b)\mathcal{R}(c, d) \Rightarrow a < c, \text{ and}$$

$$(c, d)\mathcal{R}(a, b) \Rightarrow c < a,$$

and we obtain  $a < a$ . Hence we have  $a = c$ .

And now we find that

$$(a, b)\mathcal{R}(c, d) \Rightarrow b \leq d, \text{ and}$$

$$(c, d)\mathcal{R}(a, b) \Rightarrow d \leq b,$$

so  $b = d$ . Therefore,  $(a, b)\mathcal{R}(c, d)$  and  $(c, d)\mathcal{R}(a, b) \Rightarrow (a, b) = (c, d)$ , so the relation is antisymmetric. Finally, consider  $(a, b), (c, d), (e, f) \in A$  with  $(a, b)\mathcal{R}(c, d)$  and  $(c, d)\mathcal{R}(e, f)$ .

Then

(i)  $a < c$ , or (ii)  $a = c$  and  $b \leq d$ ; and

(i)'  $c < e$ , or (ii)'  $c = e$  and  $d \leq f$ .

Consequently,

(i)''  $a < e$  or (ii)''  $a = e$  and  $b \leq f$  — so,  $(a, b)\mathcal{R}(e, f)$  and the relation is transitive.

The preceding shows that  $\mathcal{R}$  is a partial order on  $A$ .

b) & c) There is only one minimal element — namely,  $(0,0)$ . This is also the least element for this partial order.

The element  $(1,1)$  is the only maximal element for the partial order. It is also the greatest element.

d) This partial order is a total order. We find here that

$$(0,0)\mathcal{R}(0,1)\mathcal{R}(1,0)\mathcal{R}(1,1).$$

21. (a) The reflexive, antisymmetric, and transitive properties are established as in the previous exercise.

(b) & (c) Here the least element (and only minimal element) is  $(0,0)$ . The element  $(2,2)$  is the greatest element (and the only maximal element).

(d) Once again we obtain a total order, for

$$(0,0)\mathcal{R}(0,1)\mathcal{R}(0,2)\mathcal{R}(1,0)\mathcal{R}(1,1)\mathcal{R}(1,2)\mathcal{R}(2,0)\mathcal{R}(2,1)\mathcal{R}(2,2).$$

22. Here  $|X| = n + 1$ ,  $|A| = (n + 1)^2$  and  $|\mathcal{R}| = (n + 1)^2 + \binom{(n+1)^2}{2}$ .

23. (a) False. Let  $\mathcal{U} = \{1, 2\}$ ,  $A = \mathcal{P}(\mathcal{U})$ , and  $\mathcal{R}$  be the inclusion relation. Then  $(A, \mathcal{R})$  is a lattice where for all  $S, T \in A$ ,  $\text{lub}\{S, T\} = S \cup T$  and  $\text{glb}\{S, T\} = S \cap T$ . However,  $\{1\}$  and  $\{2\}$  are not related, so  $(A, \mathcal{R})$  is not a total order.

(b) If  $(A, \mathcal{R})$  is a total order, then for all  $x, y \in A$ ,  $x\mathcal{R}y$  or  $y\mathcal{R}x$ . For  $x\mathcal{R}y$ ,  $\text{lub}\{x, y\} = y$  and  $\text{glb}\{x, y\} = x$ . Consequently,  $(A, \mathcal{R})$  is a lattice.

24. Since  $A$  is finite,  $A$  has a maximal element, by Theorem 7.3. If  $x, y$  ( $x \neq y$ ) are both maximal elements, since  $x, y\mathcal{R}\text{lub}\{x, y\}$ , then  $\text{lub}\{x, y\}$  must equal either  $x$  or  $y$ . Assume  $\text{lub}\{x, y\} = x$ . Then  $y\mathcal{R}x$ , so  $y$  cannot be a maximal element. Hence  $A$  has a unique maximal element  $x$ . Now for each  $a \in A$ ,  $a \neq x$ , if  $\text{lub}\{a, x\} \neq x$ , then we contradict  $x$  being a maximal element. Hence  $a\mathcal{R}x$  for all  $a \in A$ , so  $x$  is the greatest element in  $A$ . [The proof for the least element is similar.]

25. (a)  $a$       (b)  $a$       (c)  $c$       (d)  $e$       (e)  $z$       (f)  $e$       (g)  $v$   
 $(A, \mathcal{R})$  is a lattice with  $z$  the greatest (and only maximal) element and  $a$  the least (and only minimal) element.

26. a) 5    b) and c)  $n + 1$   
d) 10    e) and f)  $n + (n - 1) + \cdots + 2 + 1 = n(n + 1)/2$ .

27. Consider the vertex  $p^a q^b r^c$ ,  $0 \leq a < m$ ,  $0 \leq b < n$ ,  $0 \leq c < k$ . There are  $mnk$  such vertices; each determines three edges — going to the vertices  $p^{a+1} q^b r^c$ ,  $p^a q^{b+1} r^c$ ,  $p^a q^b r^{c+1}$ . This accounts for  $3mnk$  edges.

Now consider the vertex  $p^m q^b r^c$ ,  $0 \leq b < n$ ,  $0 \leq c < k$ . There are  $nk$  of these vertices; each determines two edges — going to the vertices  $p^m q^{b+1} r^c$ ,  $p^m q^b r^{c+1}$ . This accounts for  $2nk$  edges. And similar arguments for the vertices  $p^a q^n r^c$  ( $0 \leq a < m$ ,  $0 \leq c < k$ ) and  $p^a q^b r^k$  ( $0 \leq a < m$ ,  $0 \leq b < n$ ) account for  $2mk$  and  $2mn$  edges, respectively.

Finally, each of the  $k$  vertices  $p^m q^n r^c$ ,  $0 \leq c < k$ , determines one edge (going to  $p^m q^n r^{c+1}$ ) and so these vertices account for  $k$  new edges. Likewise, each of the  $n$  vertices  $p^m q^b r^k$ ,  $0 \leq b < n$ , determines one edge (going to  $p^m q^{b+1} r^k$ ), and so these vertices account for  $n$  new edges. Lastly, each of the  $m$  vertices  $p^a q^n r^k$ ,  $0 \leq a < m$ , determines one edge (going to  $p^{a+1} q^n r^k$ ) and these vertices account for  $m$  new edges.

The preceding results give the total number of edges as  $(m+n+k)+2(mn+mk+nk)+3mnk$ .

28. a)  $24 = 2^3 \cdot 3$ . There are  $4 \cdot 2 = 8$  divisors for this partial order and they can be totally ordered in  $\frac{1}{5} \binom{6}{4} = 14$  ways.  
b)  $75 = 3 \cdot 5^2$ . There are  $2 \cdot 3 = 6$  divisors for this partial order and they can be totally ordered in  $\frac{1}{4} \binom{6}{3} = 5$  ways.  
c)  $1701 = 3^5 \cdot 7$ . Here the 12 divisors can be totally ordered in  $\frac{1}{7} \binom{12}{6} = 132$  ways.

29.  $429 = \left(\frac{1}{8}\right) \binom{14}{7}$  so  $k = 6$ , and there are  $2 \cdot 7 = 14$  positive integer divisors of  $p^6 q$ .

30. For the  $(0, 1)$ -matrix  $E = (e_{ij})_{m \times n}$  we have  $e_{ij} = e_{ij}$ , so  $e_{ij} \leq e_{ij}$ , for all  $1 \leq i \leq m$ ,  $1 \leq j \leq n$ . Consequently,  $E \leq E$  and the "precedes" relation is reflexive.

Now let  $E = (e_{ij})_{m \times n}$ ,  $F = (f_{ij})_{m \times n}$  be  $(0, 1)$ -matrices, with  $E \leq F$  and  $F \leq E$ . Then, for all  $1 \leq i \leq m$ ,  $1 \leq j \leq n$ ,  $e_{ij} \leq f_{ij}$  and  $f_{ij} \leq e_{ij} \Rightarrow e_{ij} = f_{ij}$ , so  $E = F$  – and the “precedes” relation is antisymmetric.

Finally, suppose that  $E = (e_{ij})_{m \times n}$ ,  $F = (f_{ij})_{m \times n}$ , and  $G = (g_{ij})_{m \times n}$  are  $(0, 1)$ -matrices, with  $E \leq F$  and  $F \leq G$ . Then, for all  $1 \leq i \leq m$ ,  $1 \leq j \leq n$ ,  $e_{ij} \leq f_{ij}$  and  $f_{ij} \leq g_{ij} \Rightarrow e_{ij} \leq g_{ij}$ , so  $E \leq G$  – and the “precedes” relation is transitive.

In so much as the “precedes” relation is reflexive, antisymmetric, and transitive, it follows that this relation is a partial order – making  $A$  into a poset.

## Section 7.4

1. (a) Here the collection  $A_1, A_2, A_3$  provides a partition of  $A$ .  
 (b) Although  $A = A_1 \cup A_2 \cup A_3 \cup A_4$ , we have  $A_1 \cap A_2 \neq \emptyset$ , so the collection  $A_1, A_2, A_3, A_4$  does *not* provide a partition for  $A$ .
2. (a) There are three choices for placing 8 — in either  $A_1, A_2$ , or  $A_3$ . Hence there are three partitions of  $A$  for the conditions given.  
 (b) There are two possibilities with  $7 \in A_1$ , and two others with  $8 \in A_1$ . Hence there are four partitions of  $A$  under these conditions.  
 (c) If we place 7,8 in the same cell for a partition we obtain three of the possibilities. If not, there are three choices of cells for 7 and two choices of cells for 8 — and six more partitions that satisfy the stated restrictions. In total — by the rules of sum and product — there are  $3 + (3)(2) = 3 + 6 = 9$  such partitions.
3.  $\mathcal{R} = \{(1, 1), (1, 2), (2, 1), (2, 2), (3, 3), (3, 4), (4, 3), (4, 4), (5, 5)\}$ .
4. (a)  $[1] = \{1, 2\} = [2]; [3] = \{3\}$   
 (b)  $A = \{1, 2\} \cup \{3\} \cup \{4, 5\} \cup \{6\}$ .
5.  $\mathcal{R}$  is not transitive since  $1\mathcal{R}2, 2\mathcal{R}3$  but  $1\not\mathcal{R}3$ .
6. (a) For all  $(x, y) \in A$ , since  $x = x$ , it follows that  $(x, y)\mathcal{R}(x, y)$ , so  $\mathcal{R}$  is reflexive. If  $(x_1, y_1), (x_2, y_2) \in A$  and  $(x_1, y_1)\mathcal{R}(x_2, y_2)$ , then  $x_1 = x_2$ , so  $x_2 = x_1$  and  $(x_2, y_2)\mathcal{R}(x_1, y_1)$ . Hence  $\mathcal{R}$  is symmetric. Finally, let  $(x_1, y_1), (x_2, y_2), (x_3, y_3) \in A$  with  $(x_1, y_1)\mathcal{R}(x_2, y_2)$  and  $(x_2, y_2)\mathcal{R}(x_3, y_3)$ .  $(x_1, y_1)\mathcal{R}(x_2, y_2) \Rightarrow x_1 = x_2; (x_2, y_2)\mathcal{R}(x_3, y_3) \Rightarrow x_2 = x_3$ . With  $x_1 = x_2, x_2 = x_3$ , it follows that  $x_1 = x_3$ , so  $(x_1, y_1)\mathcal{R}(x_3, y_3)$  and  $\mathcal{R}$  is transitive.  
 (b) Each equivalence class consists of the points on a vertical line. The collection of these vertical lines then provides a partition of the real plane.
7. (a) For all  $(x, y) \in A, x + y = x + y \Rightarrow (x, y)\mathcal{R}(x, y)$ .  
 $(x_1, y_1)\mathcal{R}(x_2, y_2) \Rightarrow x_1 + y_1 = x_2 + y_2 \Rightarrow x_2 + y_2 = x_1 + y_1 \Rightarrow$   
 $(x_2, y_2)\mathcal{R}(x_1, y_1)$ .  $(x_1, y_1)\mathcal{R}(x_2, y_2), (x_2, y_2)\mathcal{R}(x_3, y_3) \Rightarrow$

$x_1 + y_1 = x_2 + y_2, x_2 + y_2 = x_3 + y_3$ , so  $x_1 + y_1 = x_3 + y_3$  and  $(x_1, y_1) \mathcal{R}(x_3, y_3)$ . Since  $\mathcal{R}$  is reflexive, symmetric and transitive, it is an equivalence relation.

(b)  $[(1,3)] = \{(1,3), (2,2), (3,1)\};$   
 $[(2,4)] = \{(1,5), (2,4), (3,3), (4,2), (5,1)\}; [(1,1)] = \{(1,1)\}.$

(c)  $A = \{(1,1)\} \cup \{(1,2), (2,1)\} \cup \{(1,3), (2,2), (3,1)\} \cup$   
 $\{(1,4), (2,3), (3,2), (4,1)\} \cup \{(1,5), (2,4), (3,3), (4,2), (5,1)\} \cup$   
 $\{(2,5), (3,4), (4,3), (5,2)\} \cup \{(3,5), (4,4), (5,3)\} \cup \{(4,5), (5,4)\} \cup \{(5,5)\}.$

8. (a) For all  $a \in A, a - a = 3 \cdot 0$ , so  $\mathcal{R}$  is reflexive. For  $a, b \in A, a - b = 3c$ , for some  $c \in \mathbf{Z} \implies b - a = 3(-c)$ , for  $-c \in \mathbf{Z}$ , so  $a \mathcal{R} b \implies b \mathcal{R} a$  and  $\mathcal{R}$  is symmetric. If  $a, b, c \in A$  and  $a \mathcal{R} b, b \mathcal{R} c$ , then  $a - b = 3m, b - c = 3n$ , for some  $m, n \in \mathbf{Z} \implies (a - b) + (b - c) = 3m + 3n \implies a - c = 3(m + n)$ , so  $a \mathcal{R} c$ . Consequently,  $\mathcal{R}$  is transitive.

(b)  $[1] = [4] = [7] = \{1, 4, 7\}; [2] = [5] = \{2, 5\}; [3] = [6] = \{3, 6\}.$   
 $A = \{1, 4, 7\} \cup \{2, 5\} \cup \{3, 6\}.$

9. (a) For all  $(a, b) \in A$  we have  $ab = ab$ , so  $(a, b) \mathcal{R}(a, b)$  and  $\mathcal{R}$  is reflexive. To see that  $\mathcal{R}$  is symmetric, suppose that  $(a, b), (c, d) \in A$  and that  $(a, b) \mathcal{R}(c, d)$ . Then  $(a, b) \mathcal{R}(c, d) \implies ad = bc \implies cb = da \implies (c, d) \mathcal{R}(a, b)$ , so  $\mathcal{R}$  is symmetric. Finally, let  $(a, b), (c, d), (e, f) \in A$  with  $(a, b) \mathcal{R}(c, d)$  and  $(c, d) \mathcal{R}(e, f)$ . Then  $(a, b) \mathcal{R}(c, d) \implies ad = bc$  and  $(c, d) \mathcal{R}(e, f) \implies cf = de$ , so  $adf = bcf = bde$  and since  $d \neq 0$ , we have  $af = be$ . But  $af = be \implies (a, b) \mathcal{R}(e, f)$ , and consequently  $\mathcal{R}$  is transitive.

It follows from the above that  $\mathcal{R}$  is an equivalence relation on  $A$ .

(b)  $[(2, 14)] = \{(2, 14)\}$   
 $[(-3, -9)] = \{(-3, -9), (-1, -3), (4, 12)\}$   
 $[(4, 8)] = \{(-2, -4), (1, 2), (3, 6), (4, 8)\}$

- (c) There are five cells in the partition — in fact,

$$A = [(-4, -20)] \cup [(-3, -9)] \cup [(-2, -4)] \cup [(-1, -11)] \cup [(2, 14)].$$

10. (a) For all  $X \subseteq A, B \cap X = B \cap X$ , so  $X \mathcal{R} X$  and  $\mathcal{R}$  is reflexive. If  $X, Y \subseteq A$ , then  $X \mathcal{R} Y \implies X \cap B = Y \cap B \implies Y \cap B = X \cap B \implies Y \mathcal{R} X$ , so  $\mathcal{R}$  is symmetric. And finally, if  $W, X, Y \subseteq A$  with  $W \mathcal{R} X$  and  $X \mathcal{R} Y$ , then  $W \cap B = X \cap B$  and  $X \cap B = Y \cap B$ . Hence  $W \cap B = Y \cap B$ , so  $W \mathcal{R} Y$  and  $\mathcal{R}$  is transitive. Consequently  $\mathcal{R}$  is an equivalence relation on  $\mathcal{P}(A)$ .

(b)  $\{\emptyset, \{3\}\} \cup \{\{1\}, \{1, 3\}\} \cup \{\{2\}, \{2, 3\}\} \cup \{\{1, 2\}, \{1, 2, 3\}\}$

(c)  $[X] = \{\{1, 3\}, \{1, 3, 4\}, \{1, 3, 5\}, \{1, 3, 4, 5\}\}$

- (d) 8 — one for each subset of  $B$ .

11. (a)  $\binom{1}{2} \binom{6}{3}$  — The factor  $\binom{1}{2}$  is needed because each selection of size 3 should account for only one such equivalence relation, not two. For example, if  $\{a, b, c\}$  is selected we get

the partition  $\{a, b, c\} \cup \{d, e, f\}$  that corresponds with an equivalence relation. But the selection  $\{d, e, f\}$  gives us the same partition and corresponding equivalence relation.

(b)  $\binom{6}{3}[1+3] = 4\binom{6}{3}$  - After selecting 3 of the elements we can partition the remaining 3 in

(i) 1 way into three equivalence classes of size 1; or

(ii) 3 ways into one equivalence class of size 1 and one of size 2.

(c)  $\binom{6}{4}[1+1] = 2\binom{6}{4}$

(d)  $\binom{1}{2}\binom{6}{3} + 4\binom{6}{3} + 2\binom{6}{4} + \binom{6}{5} + \binom{6}{6}$

12.

(a)  $2^{10} = 1024$

(b)  $\sum_{i=1}^5 S(5, i) = 1 + 15 + 25 + 10 + 1 = 52$

(c)  $1024 - 52 = 972$

(d)  $S(5, 2) = 15$

(e)  $\sum_{i=1}^4 S(4, i) = 1 + 7 + 6 + 1 = 15$

(f)  $\sum_{i=1}^3 S(3, i) = 1 + 3 + 1 = 5$

(g)  $\sum_{i=1}^3 S(3, i) = 1 + 3 + 1 = 5$

(h)  $(\sum_{i=1}^3 S(3, i)) - (\sum_{i=1}^2 S(2, i)) = 3$

13. 300

14. (a) Not possible. With  $\mathcal{R}$  reflexive,  $|\mathcal{R}| \geq 7$ .

(b)  $\mathcal{R} = \{(x, x) | x \in \mathbf{Z}, 1 \leq x \leq 7\}$ .

(c) Not possible. With  $\mathcal{R}$  symmetric,  $|\mathcal{R}| - 7$  must be even.

(d)  $\mathcal{R} = \{(x, x) | x \in \mathbf{Z}, 1 \leq x \leq 7\} \cup \{(1, 2), (2, 1)\}$ .

(e)  $\mathcal{R} = \{(x, x) | x \in \mathbf{Z}, 1 \leq x \leq 7\} \cup \{(1, 2), (2, 1)\} \cup \{(3, 4), (4, 3)\}$ .

(f) and (h) Not possible with  $r - 7$  odd.

(g) and (i) Not possible. See the remark at the end of Section 7.4.

15. Let  $\{A_i\}_{i \in I}$  be a partition of a set  $A$ . Define  $\mathcal{R}$  on  $A$  by  $x\mathcal{R}y$  if for some  $i \in I, x, y \in A_i$ . For each  $x \in A, x, x \in A_i$  for some  $i \in I$ , so  $x\mathcal{R}x$  and  $\mathcal{R}$  is reflexive.  $x\mathcal{R}y \implies x, y \in A_i$ , for some  $i \in I \implies y, x \in A_i$ , for some  $i \in I \implies y\mathcal{R}x$ , so  $\mathcal{R}$  is symmetric. If  $x\mathcal{R}y$  and  $y\mathcal{R}z$ , then  $x, y \in A_i$  and  $y, z \in A_j$  for some  $i, j \in I$ . Since  $A_i \cap A_j$  contains  $y$  and  $\{A_i\}_{i \in I}$  is a partition, from  $A_i \cap A_j = \emptyset$  it follows that  $A_i = A_j$ , so  $i = j$ . Hence  $x, z \in A_i$ , so  $x\mathcal{R}z$  and  $\mathcal{R}$  is transitive.

16. Let  $P = \cup_{i \in I} A_i$  be a partition of  $A$ . Then  $E = \cup_{i \in I} (A_i \times A_i)$  is an equivalence relation and  $f(E) = P$ , so  $f$  is onto.

Now let  $E_1, E_2$  be two equivalence relations on  $A$ . If  $E_1 \neq E_2$ , then there exists  $x, y \in A$  where  $(x, y) \in E_1$  and  $(x, y) \notin E_2$ . Hence if  $f(E_1) = P_1 = \cup_{i \in I} A_i$  and  $f(E_2) = P_2 = \cup_{j \in J} A_j$ , then  $(x, y) \in E_1 \implies x, y \in A_i, \exists i \in I$ , while  $(x, y) \notin E_2 \implies \forall j \in J (x \notin A_j \vee y \notin A_j)$ . Consequently,  $P_1 \neq P_2$  and  $f$  is one-to-one.

17. Proof: Since  $\{B_1, B_2, B_3, \dots, B_n\}$  is a partition of  $B$ , we have  $B = B_1 \cup B_2 \cup B_3 \cup \dots \cup B_n$ . Therefore  $A = f^{-1}(B) = f^{-1}(B_1 \cup \dots \cup B_n) = f^{-1}(B_1) \cup \dots \cup f^{-1}(B_n)$  [by generalizing part (b) of Theorem 5.10]. For  $1 \leq i < j \leq n, f^{-1}(B_i) \cap f^{-1}(B_j) = f^{-1}(B_i \cap B_j) = f^{-1}(\emptyset) = \emptyset$ . Consequently,  $\{f^{-1}(B_i) | 1 \leq i \leq n, f^{-1}(B_i) \neq \emptyset\}$  is a partition of  $A$ .

Note: Part (b) of Example 7.55 is a special case of this result.

### Section 7.5

1. (a)  $P_1 : \{s_1, s_4\}, \{s_2, s_3, s_5\}$   
 $(\nu(s_1, 0) = s_4)E_1(\nu(s_4, 0) = s_1)$  but  $(\nu(s_1, 1) = s_1) \not\stackrel{E_1}{=} (\nu(s_4, 1) = s_3)$ , so  $s_1 \not\stackrel{E_1}{=} s_4$ .  
 $(\nu(s_2, 1) = s_3) \stackrel{E_1}{=} (\nu(s_3, 1) = s_4)$  so  $s_2 \stackrel{E_1}{=} s_3$ .  
 $(\nu(s_2, 0) = s_3)E_1(\nu(s_5, 0) = s_3)$  and  $(\nu(s_2, 1) = s_3)E_1(\nu(s_5, 1) = s_3)$  so  $s_2 E_2 s_5$ .  
 Since  $s_2 \stackrel{E_1}{=} s_3$  and  $s_2 E_2 s_5$ , it follows that  $s_3 \stackrel{E_2}{=} s_5$ .  
 Hence  $P_2$  is given by  $P_2 : \{s_1\}, \{s_2, s_5\}, \{s_3\}, \{s_4\}$ .  $(\nu(s_2, x) = s_3)E_2(\nu(s_5, x) = s_3)$  for  $x = 0, 1$ . Hence  $s_2 E_3 s_5$  and  $P_2 = P_3$ .

Consequently, states  $s_2$  and  $s_5$  are equivalent.

(b) States  $s_2$  and  $s_5$  are equivalent.

(c) States  $s_2$  and  $s_7$  are equivalent;  $s_3$  and  $s_4$  are equivalent.

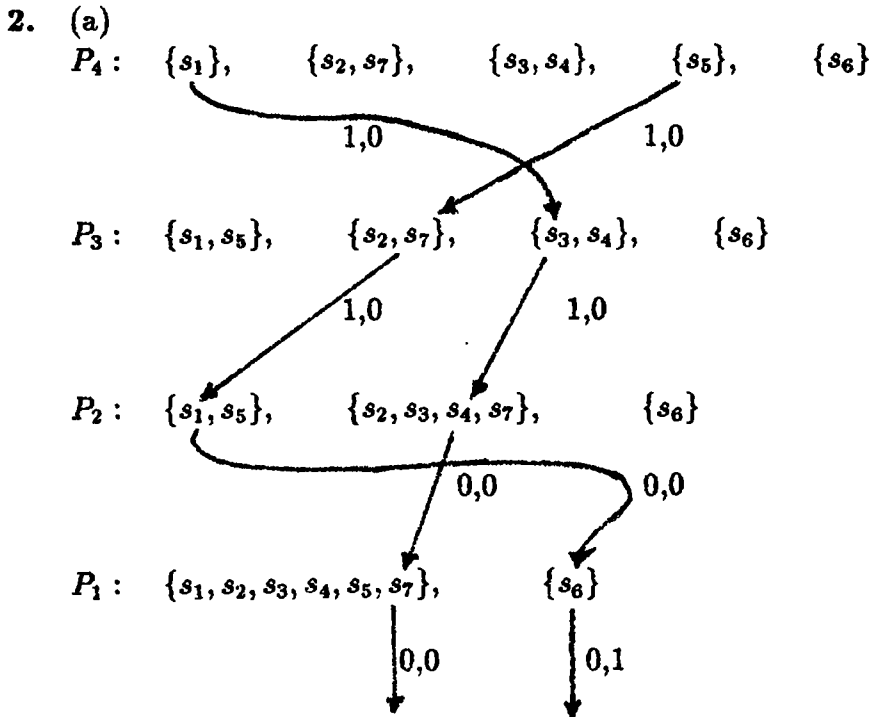

Consequently, 1100 is a distinguishing sequence since  $\omega(s_1, 1100) = 0000 \neq 0001 = \omega(s_5, 1100)$ .

(b) 100

(c) 00

3. (a)  $s_1$  and  $s_7$  are equivalent;  $s_4$  and  $s_5$  are equivalent.

(b) (i) 0000

(ii) 0

(iii) 00

	$\nu$		$\omega$	
$M:$	0	1	0	1
$s_1$	$s_4$	$s_1$	1	0
$s_2$	$s_1$	$s_2$	1	0
$s_3$	$s_6$	$s_1$	1	0
$s_4$	$s_3$	$s_4$	0	0
$s_6$	$s_2$	$s_1$	1	0

### Supplementary Exercises

1. (a) False. Let  $A = \{1, 2\}$ ,  $I = \{1, 2\}$ ,  $\mathcal{R}_1 = \{(1, 1)\}$ ,  $\mathcal{R}_2 = \{(2, 2)\}$ . Then  $\cup_{i \in I} \mathcal{R}_i$  is reflexive but neither  $\mathcal{R}_1$  nor  $\mathcal{R}_2$  is reflexive. Conversely, however, if  $\mathcal{R}_i$  is reflexive for all (actually at least one)  $i \in I$ , then  $\cup_{i \in I} \mathcal{R}_i$  is reflexive.

(b) True.  $\cap_{i \in I} \mathcal{R}_i$  reflexive  $\iff (a, a) \in \cap_{i \in I} \mathcal{R}_i$  for all  $a \in A \iff (a, a) \in \mathcal{R}_i$  for all  $a \in A$  and all  $i \in I \iff \mathcal{R}_i$  is reflexive for all  $i \in I$ .

2. (i) (a) False. Let  $A = \{1, 2\}$ ,  $\mathcal{R}_1 = \{(1, 2)\}$ ,  $\mathcal{R}_2 = \{(2, 1)\}$ . Then  $\mathcal{R}_1 \cup \mathcal{R}_2$  is symmetric although neither  $\mathcal{R}_1$  nor  $\mathcal{R}_2$  is symmetric.

Conversely, however, if each  $\mathcal{R}_i$ ,  $i \in I$ , is symmetric and  $(x, y) \in \cup_{i \in I} \mathcal{R}_i$ , then  $(x, y) \in \mathcal{R}_i$  for some  $i \in I$ . Since  $\mathcal{R}_i$  is symmetric,  $(y, x) \in \mathcal{R}_i$ , so  $(y, x) \in \cup_{i \in I} \mathcal{R}_i$  and  $\cup_{i \in I} \mathcal{R}_i$  is symmetric.

(b) If  $(x, y) \in \cap_{i \in I} \mathcal{R}_i$ , then  $(x, y) \in \mathcal{R}_i$ , for all  $i \in I$ . Since each  $\mathcal{R}_i$  is symmetric,  $(y, x) \in \mathcal{R}_i$ , for all  $i \in I$ , so  $(y, x) \in \cap_{i \in I} \mathcal{R}_i$  and  $\cap_{i \in I} \mathcal{R}_i$  is symmetric.

The converse, however, is false. Let  $A = \{1, 2, 3\}$ , with  $\mathcal{R}_1 = \{(1, 2), (2, 1), (1, 3)\}$  and  $\mathcal{R}_2 = \{(1, 2), (2, 1), (3, 2)\}$ . Then neither  $\mathcal{R}_1$  nor  $\mathcal{R}_2$  is symmetric, but  $\mathcal{R}_1 \cap \mathcal{R}_2 = \{(1, 2), (2, 1)\}$  is symmetric.

(iii) (a) Let  $A = \{1, 2, 3\}$  with  $\mathcal{R}_1 = \{(1, 2)\}$  and  $\mathcal{R}_2 = \{(2, 1)\}$ . Then both  $\mathcal{R}_1, \mathcal{R}_2$  are transitive but  $\mathcal{R}_1 \cup \mathcal{R}_2$  is not transitive.

Conversely, for  $A = \{1, 2, 3\}$  and  $\mathcal{R}_1 = \{(1, 3)\}$ ,  $\mathcal{R}_2 = \{(1, 2), (2, 3)\}$ ,  $\mathcal{R}_1 \cup \mathcal{R}_2 = \{(1, 2), (2, 3), (1, 3)\}$  is transitive although  $\mathcal{R}_2$  is not transitive.

(b) If  $(x, y), (y, z) \in \cap_{i \in I} \mathcal{R}_i$ , then  $(x, y), (y, z) \in \mathcal{R}_i$  for all  $i \in I$ . With each  $\mathcal{R}_i$ ,  $i \in I$ , transitive, it follows that  $(x, z) \in \mathcal{R}_i$ , so  $(x, z) \in \cap_{i \in I} \mathcal{R}_i$  and  $\cap_{i \in I} \mathcal{R}_i$  is transitive.

Conversely, however,  $\{(1, 2), (2, 3)\} = \mathcal{R}_1$  and  $\mathcal{R}_2 = \{(1, 2)\}$  result in the transitive relation  $\mathcal{R}_1 \cap \mathcal{R}_2 = \{(1, 2)\}$  even though  $\mathcal{R}_1$  is not transitive.

(ii) The results for part (ii) follow in a similar manner.

3.  $(a, c) \in \mathcal{R}_2 \circ \mathcal{R}_1 \implies$  for some  $b \in A$ ,  $(a, b) \in \mathcal{R}_2, (b, c) \in \mathcal{R}_1$ . With  $\mathcal{R}_1, \mathcal{R}_2$  symmetric,  $(b, a) \in \mathcal{R}_2, (c, b) \in \mathcal{R}_1$ , so  $(c, a) \in \mathcal{R}_1 \circ \mathcal{R}_2 \subseteq \mathcal{R}_2 \circ \mathcal{R}_1$ .  $(c, a) \in \mathcal{R}_2 \circ \mathcal{R}_1 \implies (c, d) \in \mathcal{R}_2, (d, a) \in \mathcal{R}_1$ , for some  $d \in A$ . Then  $(d, c) \in \mathcal{R}_2, (a, d) \in \mathcal{R}_1$  by symmetry, and  $(a, c) \in$

$\mathcal{R}_1 \circ \mathcal{R}_2$ , so  $\mathcal{R}_2 \circ \mathcal{R}_1 \subseteq \mathcal{R}_1 \circ \mathcal{R}_2$  and the result follows.

4. (a) Reflexive, symmetric.

(b) Equivalence relation. Each equivalence class is of the form  $A_r = \{t \in T \mid \text{the area of } t = r, r \in \mathbf{R}^+\}$ . Then  $T = \cup_{r \in \mathbf{R}^+} A_r$ .

(c) Reflexive, antisymmetric.

(d) Symmetric.

(e) Equivalence relation.  $[(1, 1)] = \{(1, 1), (2, 2), (3, 3), (4, 4)\}$ ;

$[(1, 2)] = \{(1, 2), (2, 1), (2, 3), (3, 2), (3, 4), (4, 3)\}$ ;

$[(1, 3)] = \{(1, 3), (3, 1), (2, 4), (4, 2)\}$ ;  $[(1, 4)] = \{(1, 4), (4, 1)\}$ .

$A = [(1, 1)] \cup [(1, 2)] \cup [(1, 3)] \cup [(1, 4)]$ .

5.  $(c, a) \in (\mathcal{R}_1 \circ \mathcal{R}_2)^c \iff (a, c) \in \mathcal{R}_1 \circ \mathcal{R}_2 \iff (a, b) \in \mathcal{R}_1, (b, c) \in \mathcal{R}_2, \text{ for some } b \in B \iff (c, b) \in \mathcal{R}_2^c, (b, a) \in \mathcal{R}_1^c, \text{ for some } b \in B \iff (c, a) \in \mathcal{R}_2^c \circ \mathcal{R}_1^c$ .

6. (a) If  $P$  is a partition of  $A$  then  $P \leq P$ , so  $\mathcal{R}$  is reflexive. For partitions  $P_i, P_j$  of  $A$  if  $P_i \leq P_j$  and  $P_j \leq P_i$ , then  $P_i = P_j$  and  $\mathcal{R}$  is antisymmetric. Finally, if  $P_i, P_j, P_k$  are partitions of  $A$  and  $P_i \mathcal{R} P_j, P_j \mathcal{R} P_k$ , then  $P_i \leq P_j$  and  $P_j \leq P_k$ , so each cell of  $P_i$  is contained in a cell of  $P_k$  and  $P_i \leq P_k$ . Hence  $\mathcal{R}$  is transitive and is a partial order.

(b)

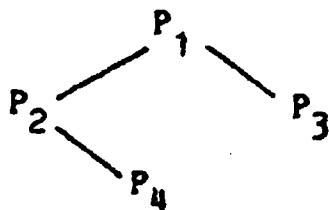

7. Let  $\mathcal{U} = \{1, 2, 3, 4, 5\}$ ,  $A = \mathcal{P}(\mathcal{U}) - \{\mathcal{U}, \emptyset\}$ . Under the inclusion relation  $A$  is a poset with the five minimal elements  $\{x\}, 1 \leq x \leq 5$ , but no least element. Also,  $A$  has five maximal elements - the five subsets of  $\mathcal{U}$  of size 4 - but no greatest element.

8. (b)  $[(1, 1)] = \{(1, 1)\}$ ;  $[(2, 2)] = \{(1, 4), (2, 2), (4, 1)\}$ ;

$[(3, 2)] = \{(1, 6), (2, 3), (3, 2), (6, 1)\}$ ;  $[(4, 3)] = \{(2, 6), (3, 4), (4, 3), (6, 2)\}$ .

9.  $n = 10$

10. (a) For each  $f \in \mathcal{F}$ ,  $|f(n)| \leq 1|f(n)|$  for all  $n \geq 1$ , so  $f \mathcal{R} f$ , and  $\mathcal{R}$  is reflexive. Second, if  $f, g \in \mathcal{F}$ , then  $f \mathcal{R} g \implies (f \in O(g) \text{ and } g \in O(f)) \implies (g \in O(f) \text{ and } f \in O(g)) \implies g \mathcal{R} f$ , so  $\mathcal{R}$  is symmetric. Finally, let  $f, g, h \in \mathcal{F}$  with  $f \mathcal{R} g, g \mathcal{R} f, g \mathcal{R} h$ , and  $h \mathcal{R} g$ . Then there exist  $m_1, m_2 \in \mathbf{R}^+$ , and  $k_1, k_2 \in \mathbf{Z}^+$  so that  $|f(n)| \leq m_1|g(n)|$  for all  $n \geq k_1$ , and  $|g(n)| \leq m_2|h(n)|$  for all  $n \geq k_2$ . Consequently, for all  $n \geq \max\{k_1, k_2\}$  we have  $|f(n)| \leq m_1|g(n)| \leq m_1 m_2|h(n)|$  so  $f \in O(h)$ . And in a similar manner  $h \in O(f)$ . So  $f \mathcal{R} h$  and  $\mathcal{R}$  is transitive.

(b) For each  $f \in \mathcal{F}$ ,  $f$  is dominated by itself, so  $[f] \mathcal{S} [f]$  and  $\mathcal{S}$  is reflexive. Second, if  $[g], [h] \in \mathcal{F}'$  with  $[g] \mathcal{S} [h]$  and  $[h] \mathcal{S} [g]$ , then  $g \mathcal{R} h$  (as in part (a)), and  $[g] = [h]$ . Consequently,  $\mathcal{S}$  is antisymmetric. Finally, if  $[f], [g], [h] \in \mathcal{F}'$  with  $[f] \mathcal{S} [g]$  and  $[g] \mathcal{S} [h]$ , then  $f$  is dominated

by  $g$  and  $g$  is dominated by  $h$ . So, as in part (a),  $f$  is dominated by  $h$  and  $[f]S[h]$ , making  $S$  transitive.

(c) Let  $f, f_1, f_2 \in \mathcal{F}$  with  $f(n) = n$ ,  $f_1(n) = n+3$ , and  $f_2(n) = 2-n$ . Then  $(f_1+f_2)(n) = 5$ , and  $f_1+f_2 \notin [f]$ , because  $f$  is not dominated by  $f_1+f_2$ .

11.

(a)

Adjacency List		Index List	
1	2	1	1
2	3	2	2
3	1	3	3
4	4	4	5
5	5	5	6
6	3	6	8
7	5		

(b)

Adjacency List		Index List	
1	2	1	1
2	3	2	2
3	1	3	3
4	5	4	4
5	4	5	5
		6	6

(c)

Adjacency List		Index List	
1	2	1	1
2	3	2	2
3	1	3	3
4	4	4	6
5	5	5	7
6	1	6	8
7	4		

12.

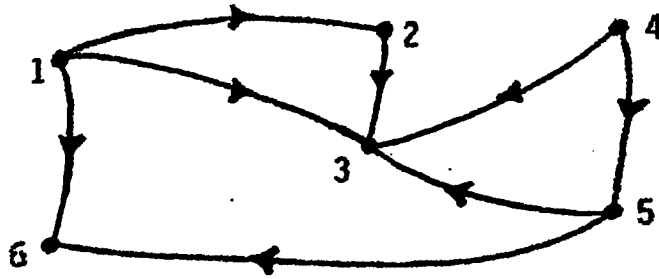

13. (a) For each  $v \in V, v = v$  so  $vRv$ . If  $vRw$  then there is a path from  $v$  to  $w$ . Since the graph  $G$  is undirected, the path from  $v$  to  $w$  is also a path from  $w$  to  $v$ , so  $wRv$  and  $R$  is symmetric. Finally, if  $vRw$  and  $wRx$ , then a subset of the edges in the paths from  $v$  to  $w$  and  $w$  to  $x$  provide a path from  $v$  to  $x$ . Hence  $R$  is transitive and  $R$  is an equivalence relation.
- (b) The cells of the partition are the (connected) components of  $G$ .

14. (a)  $P_1 : \{s_1, s_3, s_7\}, \{s_2, s_4, s_5, s_6, s_8\}$   
 $P_2 : \{s_1, s_3, s_7\}, \{s_2, s_5, s_8\}, \{s_4, s_6\}$   
 $P_3 : \{s_1\}, \{s_3, s_7\}, \{s_2, s_5, s_8\}, \{s_4\}, \{s_6\}$   
 $P_4 = P_3$

M:	$\nu$		$\omega$	
	0	1	0	1
$s_1$	$s_3$	$s_6$	1	0
$s_2$	$s_3$	$s_3$	0	0
$s_3$	$s_3$	$s_2$	1	0
$s_4$	$s_2$	$s_3$	0	0
$s_6$	$s_4$	$s_1$	0	0

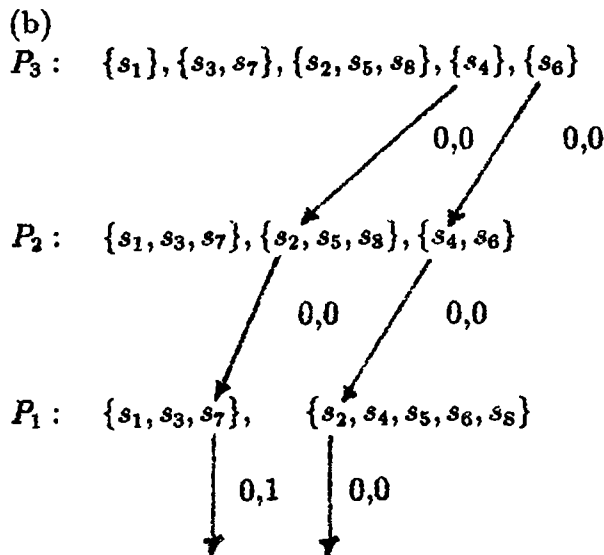

Hence  $\omega(s_4, 000) = 001 \neq 000 = \omega(s_6, 000)$ , so 000 is a distinguishing string for  $s_4$  and  $s_6$ .

15. One possible order is 10, 3, 8, 6, 7, 9, 1, 4, 5, 2, where program 10 is run first and program 2 last.

16. (a) (i)  $n = 2$ :



(ii)  $n = 4$ :



(iii)  $n = 6$ :

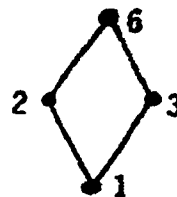

(iv)  $n = 8$ :



(v)  $n = 12$ :

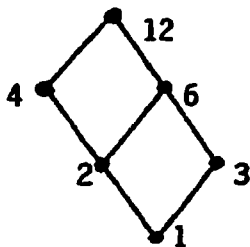

(vi)  $n = 16$ :



(vii)  $n = 24$ :

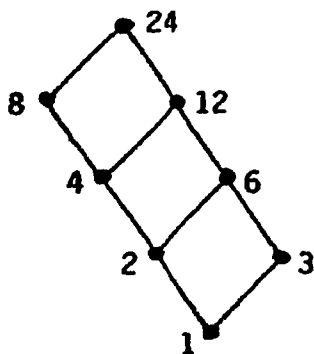

(viii)  $n = 30$ :

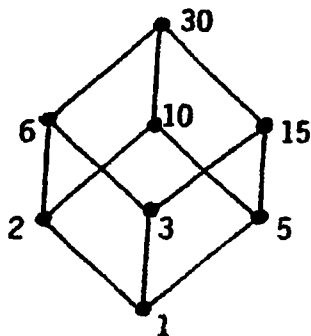

(ix)  $n = 32$ :



(b) For  $2 \leq n \leq 35$ ,  $n$  can be written in one of the following nine forms: (i)  $p$ ; (ii)  $p^2$ ; (iii)  $pq$ ; (iv)  $p^3$ ; (v)  $p^2q$ ; (vi)  $p^4$ ; (vii)  $p^3q$ ; (viii)  $pqr$ ; (ix)  $p^5$ , where  $p, q, r$  denote distinct primes. The Hasse diagrams for these representations are given by the structures in part (a).

For  $n = 36 = 2^2 \cdot 3^2$ , we must introduce a new structure.

(c) The converse is false.  $\tau(24) = 8 = \tau(30)$  but the Hasse diagrams in (vii) and (viii) of part (a) are not the same.

(d) This follows from the definitions of the gcd and lcm and the result of Example 4.45.

17. (b)  $\{(0.3, 0.7)\} = \{(0.3, 0.7)\}$      $\{(0.5, 0)\} = \{(0.5, 0)\}$      $\{(0.4, 1)\} = \{(0.4, 1)\}$

$$[(0, 0.6)] = \{(0, 0.6), (1, 0.6)\} \quad [(1, 0.2)] = \{(0, 0.2), (1, 0.2)\}$$

In general, if  $0 < a < 1$ , then  $[(a, b)] = \{(a, b)\}$ ; otherwise,  $[(0, b)] = \{(0, b), (1, b)\} = [(1, b)]$ .

(c) The lateral surface of a cylinder of height 1 and base radius  $1/2\pi$ .

18. (a) If  $C \subseteq \mathcal{U}$ , then  $0 \leq |C| \leq 3$ . For  $0 \leq k \leq 3$  there are  $\binom{3}{k}$  subsets  $C$  of  $\mathcal{U}$  where  $|C| = k$ ; each such subset  $C$  determines  $2^k$  subsets  $B \subseteq C$ . Hence the relation  $\mathcal{R}$  contains  $\binom{3}{0}2^0 + \binom{3}{1}2^1 + \binom{3}{2}2^2 + \binom{3}{3}2^3 = (1+2)^3 = 3^3 = 27$  ordered pairs.
- (b) For  $\mathcal{U} = \{1, 2, 3, 4\}$  the number of ordered pairs in  $\mathcal{R}$  is  $\binom{4}{0}2^0 + \binom{4}{1}2^1 + \binom{4}{2}2^2 + \binom{4}{3}2^3 + \binom{4}{4}2^4 = (1+2)^4 = 3^4 = 81$ .
- (c) For  $\mathcal{U} = \{1, 2, 3, \dots, n\}$ , where  $n \geq 1$ , there are  $3^n$  ordered pairs in the relation  $\mathcal{R}$ .
19. Since  $|\mathcal{U}| = n$ ,  $|\mathcal{P}(\mathcal{U})| = 2^n$  and so there are  $(2^n)(2^n) = 4^n$  ordered pairs of the form  $(A, B)$  where  $A, B \subseteq \mathcal{U}$ . From Exercise 18 (above) there are  $3^n$  order pairs of the form  $(A, B)$  where  $A \subseteq B$ . [Note: If  $(A, B) \in \mathcal{R}$ , then so is  $(B, A)$ .] Hence there are  $3^n + 3^n - 2^n$  ordered pairs  $(A, B)$  where either  $A \subseteq B$  or  $B \subseteq A$ , or both. We subtract  $2^n$  because we have counted the  $2^n$  ordered pairs  $(A, B)$ , where  $A = B$ , twice. Therefore the number of ordered pairs in this relation is  $4^n - (2 \cdot 3^n - 2^n) = 4^n - 2 \cdot 3^n + 2^n$ .
20. (a) There are  $2^m$  equivalence classes – one for each subset of  $B$ .
- (b)  $2^{n-m}$
21. (a) (i)  $BRARC$ ; (ii)  $BRCRF$   
 $BRARC$  is a maximal chain. There are six such maximal chains.
- (b) Here  $11 \mathcal{R} 385$  is a maximal chain of length 2, while  $2 \mathcal{R} 6 \mathcal{R} 12$  is one of length 3. The length of a longest chain for this poset is 3.
- (c) (i)  $\emptyset \subseteq \{1\} \subseteq \{1, 2\} \subseteq \{1, 2, 3\} \subseteq \mathcal{U}$ ;  
(ii)  $\emptyset \subseteq \{2\} \subseteq \{2, 3\} \subseteq \{1, 2, 3\} \subseteq \mathcal{U}$ .
- There are  $4! = 24$  such maximal chains.
- (d)  $n!$
22. If  $c_1$  is not a minimal element of  $(A, \mathcal{R})$ , then there is an element  $a \in A$  with  $a \mathcal{R} c_1$ . But then this contradicts the maximality of the chain  $(C, \mathcal{R}')$   
The proof for  $c_n$  maximal in  $(A, \mathcal{R})$  is similar.
23. Let  $a_1 \mathcal{R} a_2 \mathcal{R} \dots \mathcal{R} a_{n-1} \mathcal{R} a_n$  be a longest (maximal) chain in  $(A, \mathcal{R})$ . Then  $a_n$  is a maximal element in  $(A, \mathcal{R})$  and  $a_1 \mathcal{R} a_2 \mathcal{R} \dots \mathcal{R} a_{n-1}$  is a maximal chain in  $(B, \mathcal{R}')$ . Hence the length of a longest chain in  $(B, \mathcal{R}')$  is at least  $n - 1$ . If there is a chain  $b_1 \mathcal{R}' b_2 \mathcal{R}' \dots \mathcal{R}' b_n$  in  $(B, \mathcal{R}')$  of length  $n$ , then this is also a chain of length  $n$  in  $(A, \mathcal{R})$ . But then  $b_n$  must be a maximal element of  $(A, \mathcal{R})$ , and this contradicts  $b_n \in B$ .
24. (a)  $\{2, 3, 5\}$ ;  $\{5, 6, 7, 11\}$ ;  $\{2, 3, 5, 7, 11\}$

(b)  $\{\{1,2\},\{3,4\}\}, \{\{1,2,3\}, \{2,3,4\}\}; 4$

(c) Consider the set  $M$  of all maximal elements in  $(A, \mathcal{R})$ . If this set is not an antichain then there are two elements  $a, b \in M$  where  $a\mathcal{R}b$  or  $b\mathcal{R}a$ . Assume, without loss of generality, that  $a\mathcal{R}b$ . If this is so, then  $a$  is *not* a maximal element of  $(A, \mathcal{R})$ . Hence  $(M, (M \times M) \cap \mathcal{R})$  is an antichain in  $(A, \mathcal{R})$ .

The proof for the set of all minimal elements is similar.

25. If  $n = 1$ , then for all  $x, y \in A$ , if  $x \neq y$  then  $x\mathcal{R}y$  and  $y\mathcal{R}x$ . Hence  $(A, \mathcal{R})$  is an antichain, and the result follows.

Now assume the result true for  $n = k \geq 1$ , and let  $(A, \mathcal{R})$  be a poset where the length of a longest chain is  $k + 1$ . If  $M$  is the set of all maximal elements in  $(A, \mathcal{R})$ , then  $M \neq \emptyset$  and  $M$  is an antichain in  $(A, \mathcal{R})$ . Also, by virtue of Exercise 23 above,  $(A - M, \mathcal{R}')$ , for  $\mathcal{R}' = ((A - M) \times (A - M)) \cap \mathcal{R}$ , is a poset with  $k$  the length of a longest chain. So by the induction hypothesis  $A - M = C_1 \cup C_2 \cup \dots \cup C_k$ , a partition into  $k$  antichains. Consequently,  $A = C_1 \cup C_2 \cup \dots \cup C_k \cup M$ , a partition into  $k + 1$  antichains.

26. (a) Since  $96 = 2^5 \cdot 3$ , there are  $\frac{1}{7} \binom{12}{6} = 132$  ways to totally order the partial order of 12 positive integer divisors of 96.  
(b) Here we have  $96 > 32$  and must now totally order the partial order of 10 positive integer divisors of 48. This can be done in  $\frac{1}{6} \binom{10}{5} = 42$  ways.  
(c) Aside from 1 and 3 there are ten other positive integer divisors of 96. The Hasse diagram for the partial order of these ten integers – namely, 2, 4, 6, 8, 12, 16, 24, 32, 48, 96 – is structurally the same as the Hasse diagram for the partial order of positive integer divisors of 48. So as in part (b) the answer is 42 ways.  
(d) Here there are 14 such total orders.
27. (a) There are  $n$  edges – namely,  $(0, 1), (1, 2), (2, 3), \dots, (n - 1, n)$ .  
(b) The number of partitions, as described here, equals the number of compositions of  $n$ . So the answer is  $2^{n-1}$ .  
(c) The number of such partitions is  $2^{3-1} \cdot 2^{5-1} = 64$ , for there are  $2^{3-1}$  compositions of 3 and  $2^{5-1}$  compositions of 5 (= 12 - 7).

**PART 2**

**FURTHER TOPICS**

**IN**

**ENUMERATION**

CHAPTER 8  
THE PRINCIPLE OF INCLUSION AND EXCLUSION

**Section 8.1**

1. Let  $x \in S$  and let  $n$  be the number of conditions (from among  $c_1, c_2, c_3, c_4$ ) satisfied by  $x$ :  
 $(n = 0)$ : Here  $x$  is counted once in  $N(\bar{c}_2\bar{c}_3\bar{c}_4)$  and once in  $N(\bar{c}_1\bar{c}_2\bar{c}_3\bar{c}_4)$ .  
 $(n = 1)$ : If  $x$  satisfies  $c_1$  (and not  $c_2, c_3, c_4$ ), then  $x$  is counted once in  $N(\bar{c}_2\bar{c}_3\bar{c}_4)$  and once in  $N(c_1\bar{c}_2\bar{c}_3\bar{c}_4)$ .

If  $x$  satisfies  $c_i$ , for  $i \neq 1$ , then  $x$  is not counted in any of the three terms in the equation.  
 $(n = 2, 3, 4)$ : If  $x$  satisfies at least two of the four conditions, then  $x$  is not counted in any of the three terms in the equation.

The preceding observations show that the two sides of the given equation count the same elements from  $S$ , and this provides a combinatorial proof for the formula  $N(\bar{c}_2\bar{c}_3\bar{c}_4) = N(c_1\bar{c}_2\bar{c}_3\bar{c}_4) + N(\bar{c}_1\bar{c}_2\bar{c}_3\bar{c}_4)$ .

2. Proof (By the Principle of Mathematical Induction):

If  $t = 1$ , then we have  $\bar{N} = N(\bar{c}_1) =$  the number of elements in  $S$  that do not satisfy condition  $c_1 = N - N(c_1)$ . This is the basis step for the proof.

Now assume the result true for  $k$  conditions, where  $k (\geq 1)$  is fixed but arbitrary, and for any finite set  $S$ . That is,  $N(\bar{c}_1\bar{c}_2\bar{c}_3 \dots \bar{c}_k) = N - [N(c_1) + N(c_2) + N(c_3) + \dots + N(c_k)] + [N(c_1c_2) + N(c_1c_3) + \dots + N(c_1c_k) + N(c_2c_3) + \dots + N(c_2c_k) + \dots + N(c_3c_k) + \dots + N(c_{k-1}c_k)] - [N(c_1c_2c_3) + \dots + N(c_{k-2}c_{k-1}c_k)] + \dots + (-1)^k N(c_1c_2c_3 \dots c_k)$ .

Now consider the case for  $t = k + 1$  conditions. From the induction hypothesis we have  $N(\bar{c}_1\bar{c}_2 \dots \bar{c}_k c_{k+1}) = N(c_{k+1}) - [N(c_1c_{k+1}) + N(c_2c_{k+1}) + N(c_3c_{k+1}) + \dots + N(c_k c_{k+1})] + [N(c_1c_2c_{k+1}) + N(c_1c_3c_{k+1}) + \dots + N(c_1c_k c_{k+1}) + N(c_2c_3c_{k+1}) + \dots + N(c_2c_k c_{k+1}) + \dots + N(c_3c_k c_{k+1}) + \dots + N(c_{k-1}c_k c_{k+1})] - [N(c_1c_2c_3c_{k+1}) + \dots + N(c_{k-2}c_{k-1}c_k c_{k+1})] + \dots + (-1)^k N(c_1c_2c_3 \dots c_k c_{k+1})$ .

Subtracting this last equation from the one given in the induction hypothesis we find that  $N(\bar{c}_1\bar{c}_2\bar{c}_3 \dots \bar{c}_k\bar{c}_{k+1}) = N(\bar{c}_1\bar{c}_2\bar{c}_3 \dots \bar{c}_k) - N(\bar{c}_1\bar{c}_2\bar{c}_3 \dots \bar{c}_k c_{k+1}) = N - [N(c_1) + N(c_2) + \dots + N(c_k)] + [N(c_1c_2) + N(c_1c_3) + \dots + N(c_1c_k) + N(c_2c_3) + \dots + N(c_2c_k) + \dots + N(c_3c_k) + \dots + N(c_{k-1}c_k)] - [N(c_1c_2c_3) + \dots + N(c_{k-2}c_{k-1}c_k)] + \dots + (-1)^k N(c_1c_2c_3 \dots c_k) - N(c_{k+1}) + [N(c_1c_{k+1}) + N(c_2c_{k+1}) + \dots + N(c_k c_{k+1})] - [N(c_1c_2c_{k+1}) + N(c_1c_3c_{k+1}) + \dots + N(c_{k-1}c_k c_{k+1})] + \dots + (-1)^{k+1} N(c_1c_2c_3 \dots c_k c_{k+1}) =$

$$N - [N(c_1) + N(c_2) + \cdots + N(c_k) + N(c_{k+1})] + [N(c_1c_2) + \cdots + N(c_1c_k) + N(c_1c_{k+1}) + \cdots + N(c_{k-1}c_{k+1}) + N(c_kc_{k+1})] - [N(c_1c_2c_3) + \cdots + N(c_{k-2}c_{k-1}c_k) + \cdots + N(c_{k-1}c_kc_{k+1})] + \cdots + (-1)^{k+1}N(c_1c_2c_3 \dots c_kc_{k+1}).$$

So the Principle of Inclusion and Exclusion is true for any given finite set  $S$  and any number  $t$  ( $\geq 1$ ) of conditions - by the Principle of Mathematical Induction.

3.  $N = 100$

$$N(c_1) = 35; N(c_2) = 30; N(c_3) = 30; N(c_4) = 41$$

$$N(c_1c_2) = 9; N(c_1c_3) = 11; N(c_1c_4) = 13; N(c_2c_3) = 10; N(c_2c_4) = 14; N(c_3c_4) = 10.$$

$$N(c_1c_2c_3) = 5; N(c_1c_2c_4) = 6; N(c_1c_3c_4) = 6; N(c_2c_3c_4) = 6$$

$$N(c_1c_2c_3c_4) = 4$$

$$(a) N(\bar{c}_1\bar{c}_2c_3\bar{c}_4) = N(\bar{c}_1\bar{c}_2\bar{c}_4) - N(\bar{c}_1\bar{c}_2\bar{c}_3\bar{c}_4)$$

$$N(\bar{c}_1\bar{c}_2\bar{c}_4) = N - [N(c_1) + N(c_2) + N(c_4)]$$

$$+ [N(c_1c_2) + N(c_1c_4) + N(c_2c_4)] - N(c_1c_2c_4) = 100 - [35 + 30 + 41] + [9 + 13 + 14] - 6 = 100 - 106 + 36 - 6 = 24$$

$$N(\bar{c}_1\bar{c}_2\bar{c}_3\bar{c}_4) = 12 \text{ (as shown in Example 8.3)}$$

$$\text{So } N(\bar{c}_1\bar{c}_2c_3\bar{c}_4) = 24 - 12 = 12$$

Alternately,

$$N(\bar{c}_1\bar{c}_2\bar{c}_4) = N - [N(c_1) + N(c_2) + N(c_4)] + [N(c_1c_2) + N(c_1c_4) + N(c_2c_4)] - N(c_1c_2c_4), \text{ so}$$

$$N(\bar{c}_1\bar{c}_2c_3\bar{c}_4) = N(c_3) - [N(c_1c_3) + N(c_2c_3) + N(c_3c_4)] + [N(c_1c_2c_3) + N(c_1c_3c_4) + N(c_2c_3c_4)] - N(c_1c_2c_3c_4) = 30 - [11 + 10 + 10] + [5 + 6 + 6] - 4 = 30 - 31 + 17 - 4 = 12.$$

$$(b) N(\bar{c}_1\bar{c}_4) = N - [N(c_1) + N(c_4)] + N(c_1c_4), \text{ so } N(\bar{c}_1c_2c_3\bar{c}_4) = N(c_2c_3) - [N(c_1c_2c_3) + N(c_2c_3c_4)] + N(c_1c_2c_3c_4) = 10 - [5 + 6] + 4 = 3.$$

4.  $c_1$ : Staff member brings hot dogs

$c_2$ : Staff member brings fried chicken

$c_3$ : Staff member brings salads

$c_4$ : Staff member brings desserts

$$N = 65$$

$$N(c_1) = 21; N(c_2) = 35; N(c_3) = 28; N(c_4) = 32$$

$$N(c_1c_2) = 13; N(c_1c_3) = 10; N(c_1c_4) = 9; N(c_2c_3) = 12; N(c_2c_4) = 17; N(c_3c_4) = 14$$

$$N(c_1c_2c_3) = 4; N(c_1c_2c_4) = 6; N(c_1c_3c_4) = 5; N(c_2c_3c_4) = 7$$

$$N(c_1c_2c_3c_4) = 2.$$

$$(a) N(\bar{c}_1\bar{c}_2\bar{c}_3\bar{c}_4) = 65 - [21 + 35 + 28 + 32] + [13 + 10 + 9 + 12 + 17 + 14] - [4 + 6 + 5 + 7] + 2 = 65 - 116 + 75 - 22 + 2 = 4.$$

$$(b) N(\bar{c}_2\bar{c}_3\bar{c}_4) = N - [N(c_2) + N(c_3) + N(c_4)] + [N(c_2c_3) + N(c_2c_4) + N(c_3c_4)] - N(c_2c_3c_4), \text{ so } N(\bar{c}_1\bar{c}_2\bar{c}_3\bar{c}_4) = N(c_1) - [N(c_1c_2) + N(c_1c_3) + N(c_1c_4)] + [N(c_1c_2c_3) + N(c_1c_2c_4) + N(c_1c_3c_4)] - N(c_1c_2c_3c_4) = 21 - [13 + 10 + 9] + [4 + 6 + 5] - 2 = 21 - 32 + 15 - 2 = 2.$$

$$(c) N(\bar{c}_1c_2\bar{c}_3\bar{c}_4) = N(c_2) - [N(c_1c_2) + N(c_2c_3) + N(c_2c_4)] + [N(c_1c_2c_3) + N(c_1c_2c_4) + N(c_2c_3c_4)] - N(c_1c_2c_3c_4) = 35 - [13 + 12 + 17] + [4 + 6 + 7] - 2 = 35 - 42 + 17 - 2 = 8$$

$$\begin{aligned}
N(\bar{c}_1\bar{c}_2\bar{c}_3\bar{c}_4) &= N(c_3) - [N(c_1c_3) + N(c_2c_3) + N(c_3c_4)] + [N(c_1c_2c_3) + N(c_1c_3c_4) + N(c_2c_3c_4)] - \\
N(c_1c_2c_3c_4) &= 28 - [10 + 12 + 14] + [4 + 5 + 7] - 2 = 28 - 36 + 16 - 2 = 6. \\
N(\bar{c}_1\bar{c}_2\bar{c}_3c_4) &= N(c_4) - [N(c_1c_4) + N(c_2c_4) + N(c_3c_4)] + [N(c_1c_2c_4) + N(c_1c_3c_4) + N(c_2c_3c_4)] - \\
N(c_1c_2c_3c_4) &= 32 - [9 + 17 + 14] + [6 + 5 + 7] - 2 = 32 - 40 + 18 - 2 = 8.
\end{aligned}$$

So the answer is  $2 + 8 + 6 + 8 = 24$ .

5. (a)  $c_1$ : number  $n$  is divisible by 2  
 $c_2$ : number  $n$  is divisible by 3  
 $c_3$ : number  $n$  is divisible by 5

$$\begin{aligned}
N(c_1) &= \lfloor 2000/2 \rfloor = 1000, \quad N(c_2) = \lfloor 2000/3 \rfloor = 666, \\
N(c_3) &= \lfloor 2000/5 \rfloor = 400, \quad N(c_1c_2) = \lfloor 2000/(2)(3) \rfloor = 333, \\
N(c_2c_3) &= \lfloor 2000/(3)(5) \rfloor = 133, \quad N(c_1c_3) = \lfloor 2000/(2)(5) \rfloor = 200, \\
N(c_1c_2c_3) &= \lfloor 2000/(2)(3)(5) \rfloor = 66. \\
N(\bar{c}_1\bar{c}_2\bar{c}_3) &= 2000 - (1000 + 666 + 400) + (333 + 200 + 133) - 66 = 534
\end{aligned}$$

(b) Let  $c_1, c_2, c_3$  be as in part (a). Let  $c_4$  denote the number  $n$  is divisible by 7. Then  $N(c_4) = 285$ ,  $N(c_1c_4) = 142$ ,  $N(c_2c_4) = 95$ ,  $N(c_3c_4) = 57$ ,  $N(c_1c_2c_4) = 47$ ,  $N(c_1c_3c_4) = 28$ ,  $N(c_2c_3c_4) = 19$ ,  $N(c_1c_2c_3c_4) = 9$ .  $N(\bar{c}_1\bar{c}_2\bar{c}_3\bar{c}_4) = 2000 - (1000 + 666 + 400 + 285) + (333 + 200 + 133 + 142 + 95 + 57) - (66 + 47 + 28 + 19) + 9 = 458$

(c)  $534 - 458 = 76$ .

6.  $x_1 + x_2 + x_3 + x_4 = 19$ .

(a)  $0 \leq x_i, 1 \leq i \leq 4$ .  $\binom{4+19-1}{19} = \binom{22}{19}$

(b) For  $1 \leq i \leq 4$  let  $c_i : x_i \geq 8$ .

$$N(c_i) : x_1 + x_2 + x_3 + x_4 = 11 : \binom{4+11-1}{11} = \binom{14}{11}, 1 \leq i \leq 4$$

$$N(c_i c_j) : x_1 + x_2 + x_3 + x_4 = 3 : \binom{4+3-1}{3} = \binom{6}{3}, 1 \leq i < j \leq 4$$

$$N(\bar{c}_1\bar{c}_2\bar{c}_3\bar{c}_4) = N - S_1 + S_2 = \binom{22}{19} - 4\binom{14}{11} + 6\binom{6}{3}$$

(c) The number of solutions for  $x_1 + x_2 + x_3 + x_4 = 19$  where  $0 \leq x_1 \leq 5, 0 \leq x_2 \leq 6, 3 \leq x_3 \leq 7, 3 \leq x_4 \leq 8$  equals the number of solutions for  $x_1 + x_2 + x_3 + x_4 = 13$  with  $0 \leq x_1 \leq 5, 0 \leq x_2 \leq 6, 0 \leq x_3 \leq 4, 0 \leq x_4 \leq 5$ . Define the conditions  $c_i, 1 \leq i \leq 4$ , as follows:  $c_1 : x_1 \geq 6; c_2 : x_2 \geq 7; c_3 : x_3 \geq 5; c_4 : x_4 \geq 6$ .

$$N = \binom{4+13-1}{13} = \binom{16}{13}$$

$$N(c_1), N(c_4) : x_1 + x_2 + x_3 + x_4 = 7 : \binom{4+7-1}{7} = \binom{10}{7}$$

$$N(c_2) : x_1 + x_2 + x_3 + x_4 = 6 : \binom{4+6-1}{6} = \binom{9}{6}$$

$$N(c_3) : x_1 + x_2 + x_3 + x_4 = 8 : \binom{4+8-1}{8} = \binom{11}{8}$$

$$N(c_1c_2) = 1$$

$$N(c_1c_3) : x_1 + x_2 + x_3 + x_4 = 2 : \binom{4+2-1}{2} = \binom{5}{2}$$

$$N(c_1c_4) : x_1 + x_2 + x_3 + x_4 = 1 : \binom{4+1-1}{1} = \binom{4}{1}$$

$$N(c_2c_3) = \binom{4}{1}, N(c_2c_4) = 1, N(c_3c_4) = \binom{5}{2}$$

$$N(\bar{c}_1\bar{c}_2\bar{c}_3\bar{c}_4) = \binom{16}{13} - [2\binom{10}{7} + \binom{9}{6} + \binom{11}{8}] + 2[1 + \binom{4}{1} + \binom{5}{2}].$$

7. Let  $c_1$  denote the condition where an arrangement of these 11 letters contains two occurrences of the consecutive pair IN. Define similar conditions  $c_2, c_3, c_4, c_5$ , and  $c_6$ , for the consecutive pairs NI, IO, OI, NO, and ON, respectively. Then

$$N = S_0 = 11!/(2!)^3;$$

$$N(c_1) = 9!/(2!)^2, S_1 = \binom{6}{1}[9!/(2!)^2];$$

$$N(c_1c_2) = N(c_1c_3) = N(c_1c_6) = N(c_2c_4) = N(c_2c_5) = N(c_3c_4) = N(c_3c_5) = N(c_4c_6) = N(c_5c_6) = 0, N(c_1c_4) = 7!/2!, \text{ and } S_2 = (6)[7!/2!]; \text{ and}$$

$$S_3 = S_4 = S_5 = S_6 = 0.$$

Consequently, the number of arrangements under the given restrictions is  $N(\bar{c}_1\bar{c}_2\bar{c}_3\bar{c}_4\bar{c}_5\bar{c}_6) = S_0 - S_1 + S_2 = [11!/(2!)^3] - \binom{6}{1}[9!/(2!)^2] + (6)[7!/2!] = 4,989,600 - 544,320 + 15,120 = 4,460,400.$

8. The number of integer solutions for  $x_1 + x_2 + x_3 + x_4 = 19, -5 \leq x_1 \leq 10, 1 \leq i \leq 4$ , equals the number of integer solutions for  $y_1 + y_2 + y_3 + y_4 = 39, 0 \leq y_i \leq 15.$

For  $1 \leq i \leq 4$ , let  $c_i : y_i \geq 16.$

$$N(c_i), 1 \leq i \leq 4 : y_1 + y_2 + y_3 + y_4 = 23 : \binom{4+23-1}{23} = \binom{26}{23}$$

$$N(c_i c_j), 1 \leq i < j \leq 4 : y_1 + y_2 + y_3 + y_4 = 7 : \binom{4+7-1}{7} = \binom{10}{7}$$

$$N(\bar{c}_1\bar{c}_2\bar{c}_3\bar{c}_4) = \binom{42}{39} - \binom{4}{1}\binom{26}{23} + \binom{4}{2}\binom{10}{7}$$

9. Let  $x$  be written (in base 10) as  $x_1x_2\dots x_7$ . Then the answer to the problem is the number of nonnegative integer solutions to  $x_1 + x_2 + \dots + x_7 = 31, 0 \leq x_i \leq 9$  for  $1 \leq i \leq 7.$

If  $1 \leq j \leq 7$ , let  $c_j$  denote the condition that  $x_1, x_2, \dots, x_7$  is an integer solution of  $x_1 + x_2 + \dots + x_7 = 31, 0 \leq x_i, 1 \leq i \leq 7$ , but  $x_j > 9$  (or  $x_j \geq 10$ ).

$N(c_1)$  is the number of integer solutions for  $y_1 + x_2 + x_3 + \dots + x_7 = 21, 0 \leq y_1, 0 \leq x_i$  for  $2 \leq i \leq 7$ . Here  $N(c_1) = \binom{27}{21}$  and  $S_1 = \binom{7}{1}\binom{27}{21}.$

$N(c_1c_2)$  is the number of integer solutions for  $y_1 + y_2 + x_3 + \dots + x_7 = 11, 0 \leq y_1, y_2, 0 \leq x_i$  for  $3 \leq i \leq 7$ . One finds  $N(c_1c_2) = \binom{17}{11}$  and  $S_2 = \binom{7}{2}\binom{17}{11}.$

In a similar way we obtain  $S_3 = \binom{7}{3}\binom{7}{1}$  and  $S_4 = S_5 = S_6 = S_7 = 0.$  Since  $N = S_0 = \binom{37}{31}$ , we have  $N(\bar{c}_1\bar{c}_2\dots\bar{c}_7) = \binom{37}{31} - \binom{7}{1}\binom{27}{21} + \binom{7}{2}\binom{17}{11} - \binom{7}{3}\binom{7}{1}.$

10. Here we are working with units of 5 credits. So we are seeking the number of credit assignments where each question receives at least 2, but not more than 5, units (of 5 credits). Hence the answer is the number of (nonnegative) integer solutions to  $z_1 + z_2 +$

$z_3 + \dots + z_{12} = 16$  (units of 5 credits) where  $0 \leq z_i \leq 3$  for all  $1 \leq i \leq 12$ . We find the answer to be  $\binom{12+16-1}{16} - \binom{12}{1} \binom{12+12-1}{12} + \binom{12}{2} \binom{12+8-1}{8} - \binom{12}{3} \binom{12+4-1}{4} + \binom{12}{4} \binom{12+0-1}{0} = \binom{27}{16} - \binom{12}{1} \binom{23}{12} + \binom{12}{2} \binom{19}{8} - \binom{12}{3} \binom{15}{4} + \binom{12}{4} \binom{11}{0}$ .

11. For each distribution of the 15 plants there are  $15!$  arrangements. Consequently, in order to answer this question we need to know the number of positive integer solutions for  $x_1 + x_2 + x_3 + x_4 + x_5 = 15$ , where  $1 \leq x_i \leq 4$  for all  $1 \leq i \leq 5$ .

This is equal to the number of nonnegative integer solutions for

$y_1 + y_2 + y_3 + y_4 + y_5 = 10$ , where  $0 \leq y_i \leq 3$  for all  $1 \leq i \leq 5$ . [Here  $y_i + 1 = x_i$  for all  $1 \leq i \leq 5$ .]

For  $1 \leq i \leq 5$  let  $c_i$  denote the condition that  $y_1 + y_2 + y_3 + y_4 + y_5 = 10$  where  $y_i \geq 4$  (or  $y_i > 3$ ) and  $y_j \geq 0$  for  $1 \leq j \leq 5$  and  $j \neq i$ . Then  $N(c_i)$  is the number of nonnegative integer solutions for

$z_1 + z_2 + z_3 + z_4 + z_5 = 6$ . [Here  $z_1 + 4 = y_1$ , and  $z_i = y_i$  for all  $2 \leq i \leq 5$ .] This is  $\binom{5+6-1}{6} = \binom{10}{6}$ , and so  $S_1 = \binom{5}{1} \binom{10}{6}$ .

If  $1 \leq i < j \leq 5$ ,  $N(c_i c_j)$  is the number of nonnegative integer solutions for

$w_1 + w_2 + w_3 + w_4 + w_5 = 2$ . [Here  $w_i + 4 = y_i$ ,  $w_j + 4 = y_j$  and  $w_k = y_k$  for all  $1 \leq k \leq 5$ ,  $k \neq i, j$ .]

This is  $\binom{5+2-1}{2} = \binom{6}{2}$ , and so  $S_2 = \binom{5}{2} \binom{6}{2}$ .

Similar calculations show us that  $S_3 = S_4 = S_5 = 0$ , and so  $N(\bar{c}_1 \bar{c}_2 \bar{c}_3 \bar{c}_4 \bar{c}_5) = S_0 - S_1 + S_2 = \binom{5+10-1}{10} - \binom{5}{1} \binom{10}{6} + \binom{5}{2} \binom{6}{2} = \binom{14}{10} - \binom{5}{1} \binom{10}{6} + \binom{5}{2} \binom{6}{2}$ .

Consequently, Flo can arrange these 25 plants, according to the restrictions given, in  $(15!)[\binom{14}{10} - \binom{5}{1} \binom{10}{6} + \binom{5}{2} \binom{6}{2}]$  ways.

12. The answer is the number of integer solutions for  $x_1 + x_2 + x_3 + x_4 = 9$ ,  $0 \leq x_i \leq 3$ ,  $1 \leq i \leq 4$ . For  $1 \leq i \leq 4$  let  $c_i$  denote that  $x_1, x_2, x_3, x_4$  is a solution with  $x_i \geq 4$ . Then  $N(\bar{c}_1 \bar{c}_2 \bar{c}_3 \bar{c}_4) = \binom{12}{9} - \binom{4}{1} \binom{8}{5} + \binom{4}{2} \binom{4}{1}$ .

13. Let  $c_1$  denote that the arrangement contains the pattern *spin*. Likewise, let  $c_2, c_3, c_4$  denote this for the patterns *game*, *path*, and *net*, respectively.  $N(\bar{c}_1 \bar{c}_2 \bar{c}_3 \bar{c}_4) = 26! - [3(23!) + 24!] - (20! + 21!)$

14. Let  $a, b, c, d, e, f$  denote the six villages. For  $1 \leq i \leq 6$ , let  $c_i$  be the condition that a system of two-way roads isolates village  $a, b, c, d, e, f$ , respectively.

$N(c_1) = 2^{10}$ ,  $S_1 = \binom{6}{1} 2^{10}$ ;  $N(c_1 c_2) = 2^6$ ,  $S_2 = \binom{6}{2} 2^6$ ;  $N(c_1 c_2 c_3) = 2^3$ ,  $S_3 = \binom{6}{3} 2^3$ ;

$N(c_1 c_2 c_3 c_4) = 2^1$ ,  $S_4 = \binom{6}{4} 2^1$ ;  $N(c_1 c_2 c_3 c_4 c_5) = 2^0$ ,  $S_5 = \binom{6}{5} 2^0$ ;  $S_6 = 1$ .

$N(\bar{c}_1 \bar{c}_2 \bar{c}_3 \bar{c}_4 \bar{c}_5 \bar{c}_6) = 2^{15} - \binom{6}{1} 2^{10} + \binom{6}{2} 2^6 - \binom{6}{3} 2^3 + \binom{6}{4} 2^1 - \binom{6}{5} 2^0 + \binom{6}{6} (1)$ .

15.  $[6^8 - \binom{6}{1} 5^8 + \binom{6}{2} 4^8 - \binom{6}{3} 3^8 + \binom{6}{4} 2^8 - \binom{6}{5} 1^8] / 6^8$ .

16.  $10^9 - \binom{3}{1} (9^9) + \binom{3}{2} (8^9) - \binom{3}{3} (7^9)$ .

17. Let  $c_1$ : the three  $x$ 's are together;  $c_2$ : the three  $y$ 's are together; and  $c_3$ : the three  $z$ 's are together.

$$\begin{aligned}
N &= 9! / [(3!)^3] & N(c_1) &= N(c_2) = N(c_3) = 7! / [(3!)^2] \\
N(c_i c_j) &= (5!) / (3!), & 1 \leq i < j \leq 3 & & N(c_1 c_2 c_3) &= 3! \\
N(\bar{c}_1 \bar{c}_2 \bar{c}_3) &= 9! / [(3!)^3] - 3[7! / [(3!)^2]] + 3(5! / 3!) - 3!
\end{aligned}$$

18. Here we need the number of integer solutions for

$$x_1 + x_2 + x_3 + x_4 = 50,$$

where  $1 \leq x_i \leq 20$  for  $i = 1, 2, 3, 4$ .

This is the same as the number of integer solutions for

$$y_1 + y_2 + y_3 + y_4 = 46, \quad (*)$$

where  $0 \leq y_i \leq 19$  for  $i = 1, 2, 3, 4$ .

Let  $S$  be the set of integer solutions for equation (\*) where  $0 \leq y_i$  for  $1 \leq i \leq 4$ . Then  $N = S_0 = |S| = \binom{4+46-1}{46} = \binom{49}{46}$ . So define conditions  $c_1, c_2, c_3, c_4$  on the elements of  $S$  as follows:

$c_i : (y_1, y_2, y_3, y_4) \in S$  but  $y_i > 19$  ( $\geq 20$ ),  $i = 1, 2, 3, 4$ . Then

$$N(c_i) = \binom{4+26-1}{26} = \binom{29}{26}, \quad 1 \leq i \leq 4;$$

$$N(c_i c_j) = \binom{4+6-1}{6} = \binom{9}{6}, \quad 1 \leq i < j \leq 4;$$

$N(c_i c_j c_k) = 0$ ,  $1 \leq i < j < k \leq 4$ ; and  $N(c_1 c_2 c_3 c_4) = 0$ . Consequently,

$$\begin{aligned}
N(\bar{c}_1 \bar{c}_2 \bar{c}_3 \bar{c}_4) &= S_0 - S_1 + S_2 - S_3 + S_4 = \binom{49}{46} - \binom{4}{1} \binom{29}{26} + \binom{4}{2} \binom{9}{6} \\
&= 18424 - (4)(3654) + (6)(84) = 4312.
\end{aligned}$$

So the probability the selection includes at least one boy from each of the four troops is  $4312 / \binom{49}{46} = 4312 / 18424 \doteq 0.234$ .

19. Here we need to know the number of integer solutions for

$$x_1 + x_2 + x_3 + x_4 + x_5 = 20,$$

where  $1 \leq x_i \leq 6$  for  $1 \leq i \leq 5$ .

This is equal to the number of integer solutions for

$$y_1 + y_2 + y_3 + y_4 + y_5 = 15,$$

with  $0 \leq y_i \leq 5$  for  $1 \leq i \leq 5$ .

If  $1 \leq i \leq 5$  then let  $c_i$  denote the condition that  $y_1, y_2, y_3, y_4, y_5$  is a solution for  $y_1 + y_2 + y_3 + y_4 + y_5 = 15$ , where  $0 \leq y_j$  for  $1 \leq j \leq 5$  and  $j \neq i$ , but  $y_i \geq 6$ . Then the number of integer solutions for

$$y_1 + y_2 + y_3 + y_4 + y_5 = 15,$$

where  $0 \leq y_i \leq 5$  for  $1 \leq i \leq 5$ , is  $N(\bar{c}_1 \bar{c}_2 \bar{c}_3 \bar{c}_4 \bar{c}_5)$ .

$N$ : Here  $N$  counts the number of nonnegative integer solutions for  $y_1 + y_2 + y_3 + y_4 + y_5 = 15$ . This number is  $\binom{5+15-1}{15} = \binom{19}{15}$ . [Hence  $S_0 = \binom{19}{15}$ .]

$N(c_1)$ : To determine  $N(c_1)$  we need to find the number of nonnegative integer solutions for

$$z_1 + z_2 + z_3 + z_4 + z_5 = 9,$$

where  $z_i = y_i$  for  $i \neq 1$ , and  $y_1 = z_1 + 6$ . Consequently,  $N(c_1) = \binom{5+9-1}{9} = \binom{13}{9}$ , and  $S_1 = \binom{5}{1} \binom{13}{9}$ .

$N(c_1 c_2)$ : Now we need to count the number of nonnegative integer solutions for

$$w_1 + w_2 + w_3 + w_4 + w_5 = 3,$$

where  $w_i = y_i$ , for  $i = 3, 4, 5$ ;  $y_1 = w_1 + 6$ , and  $y_2 = w_2 + 6$ . This number is  $\binom{5+3-1}{3} = \binom{7}{3}$ , and, as a result, we have  $S_2 = \binom{5}{2} \binom{7}{3}$ .

Since  $S_3 = S_4 = S_5 = 0$ , it follows that  $N(\bar{c}_1 \bar{c}_2 \bar{c}_3 \bar{c}_4 \bar{c}_5) = S_0 - S_1 + S_2 = \binom{19}{15} - \binom{5}{1} \binom{13}{9} + \binom{5}{2} \binom{7}{3} = 3876 - (5)(715) + (10)(35) = 3876 - 3575 + 350 = 651$ .

The sample space here is  $S = \{(x_1, x_2, x_3, x_4, x_5) | 1 \leq x_i \leq 6, \text{ for } 1 \leq i \leq 5\}$ . And since  $|S| = 6^5 = 7776$ , it follows that the probability that the sum of Zachary's five rolls is 20 equals  $651/7776 \doteq 0.08372$ .

20. For  $1 \leq i \leq 7$ , let  $c_i$  denote the situation where the  $i$ -th friend was at lunch with Sharon. Then  $N(\bar{c}_1 \bar{c}_2 \dots \bar{c}_7) = 84 - \binom{7}{1}(35) + \binom{7}{2}(16) - \binom{7}{3}(8) + \binom{7}{4}(4) - \binom{7}{5}(2) + \binom{7}{6}(1) - \binom{7}{7}(0) = 0$ . Consequently, Sharon always had company at lunch.

21. (a) 32 (b) 96 (c) 3200

22. (a)  $5186 = (2)(2593)$ , and  $\phi(5186) = (5186)(1/2)(2592/2593) = 2592$ .  
 (b)  $5187 = (3)(7)(13)(19)$ , so  $\phi(5187) = (5187)(2/3)(6/7)(12/13)(18/19) = (2)(6)(12)(18) = 2592$ .  
 (c)  $5188 = (2^2)(1297)$ , and  $\phi(5188) = (5188)(1/2)(1296/1297) = 2592$ .  
 Hence  $\phi(5186) = \phi(5187) = \phi(5188)$ .

23. (a)  $2^{n-1}$  (b)  $2^{n-1}(p-1)$

24.  $\phi(n)$  odd  $\implies n = 2$ .

25. (a)  $\phi(6000) = \phi(2^4 \cdot 3 \cdot 5^3) = 6000(1 - (1/2))(1 - (1/3))(1 - (1/5)) = 1600$ .  
 (b)  $6000 - 1600 - 1$  (for 6000) = 4399.

26. Proof:  $\phi(n^m) = (n^m) \prod_{p|n^m} (1 - \frac{1}{p})$ . But for every prime  $p$  it follows from Lemma 4.3 that if  $p|n^m$  then  $p|n$ . Therefore,

$$\phi(n^m) = (n^m) \prod_{p|n^m} (1 - \frac{1}{p}) = (n^{m-1}) [n \prod_{p|n} (1 - \frac{1}{p})] = n^{m-1} \phi(n).$$

27.  $\phi(17) = \phi(32) = \phi(48) = 16$ .

28. For  $\phi(n)$  to be a power of 2 we must have one of the following:

(1)  $n = 2^k$ , for  $k \geq 1$ ;

- (2)  $n = p_1 p_2 \cdots p_t$ , where  $t \geq 1$  and each prime  $p_i$  has the form  $2^{k_i} + 1$ , for  $1 \leq i \leq t$ ; or  
 (3)  $n = 2^k p_1 p_2 \cdots p_t$ , where  $k \geq 1$ ,  $t \geq 1$ , and each prime  $p_i$  has the form  $2^{k_i} + 1$ , for  $1 \leq i \leq t$ .

29. If 4 divides  $\phi(n)$  then one of the following must hold:

- (1)  $n$  is divisible by 8;  
 (2)  $n$  is divisible by two (or more) distinct odd primes;  
 (3)  $n$  is divisible by an odd prime  $p$  (such as 5, 13, and 17) where 4 divides  $p - 1$ ; and  
 (4)  $n$  is divisible by 4 (and not 8) and at least one odd prime.

30. For  $1 \leq i \leq 5$  let condition  $c_i$  denote the situation where the seating arrangement has family  $i$  seated all together. Then the answer to this problem is  $N(\bar{c}_1 \bar{c}_2 \bar{c}_3 \bar{c}_4 \bar{c}_5)$ .

Here  $S_0$  is the number of ways one can arrange 15 distinct objects around a circular table. This is  $(15 - 1)! = 14!$

$N(c_1) = 6(13 - 1)! = 6(12!)$ , for there are  $(13 - 1)! = 12!$  ways to arrange 13 distinct objects [family 1 (considered as one object) and the other 12 people] and 6 ways to seat the three members of family 1 so that they are side by side. Consequently,  $S_1 = \binom{5}{1} 6(12!)$ . Similar reasoning leads us to

$$\begin{aligned} N(c_1 c_2) &= 6^2(10!) & S_2 &= \binom{5}{2} 6^2(10!) & N(c_1 c_2 c_3) &= 6^3(8!) & S_3 &= \binom{5}{3} 6^3(8!) \\ N(c_1 c_2 c_3 c_4) &= 6^4(6!) & S_4 &= \binom{5}{4} 6^4(6!) & N(c_1 c_2 c_3 c_4 c_5) &= 6^5(4!) & S_5 &= \binom{5}{5} 6^5(4!). \end{aligned}$$

Therefore,  $N(\bar{c}_1 \bar{c}_2 \bar{c}_3 \bar{c}_4 \bar{c}_5) = S_0 - S_1 + S_2 - S_3 + S_4 - S_5 = \sum_{i=0}^5 (-1)^i \binom{5}{i} 6^i (14 - 2i)! = 87,178,291,200 - 14,370,048,000 + 1,306,368,000 - 87,091,200 + 4,665,600 - 186,624 = 74,031,998,976$ .

## Section 8.2

1.  $E_0 = 768$ ;  $E_1 = 205$ ;  $E_2 = 40$ ;  $E_3 = 10$ ;  $E_4 = 0$ ;  $E_5 = 1$ .

$$\sum_{i=0}^5 E_i = 1024 = N.$$

2. (a) Let  $c_1$  denote the condition that the two A's are together in an arrangement of ARRANGEMENT. Conditions  $c_2, c_3, c_4$  are defined similarly for the two E's, N's, and R's, respectively.

$$N = (11!)/[(2!)^4] = 2494800$$

$$\text{For } 1 \leq i \leq 4, N(c_i) = (10!)/[(2!)^3] = 453600.$$

$$\text{For } 1 \leq i < j \leq 4, N(c_i c_j) = (9!)/[(2!)^2] = 90720.$$

$$N(c_i c_j c_k) = (8!)/(2!) = 20160, \quad 1 \leq i < j < k \leq 4.$$

$$N(c_1 c_2 c_3 c_4) = 7! = 5040$$

$$S_1 = \binom{4}{1} (453600) = 1814400$$

$$S_2 = \binom{4}{2} (90720) = 544320$$

$$S_3 = \binom{4}{3}(20160) = 80640$$

$$S_4 = \binom{4}{4}(5040) = 5040$$

$$(i) E_2 = S_2 - \binom{3}{1}S_3 + \binom{4}{2}S_4 = 544320 - (3)(80640) + (6)(5040) = 332640$$

$$(ii) L_2 = S_2 - \binom{2}{1}S_3 + \binom{3}{1}S_4 = 398160$$

$$(b) (i) E_3 = S_3 - \binom{4}{1}S_4 = 60480 \quad (ii) L_3 = S_3 - \binom{3}{2}S_4 = 65520$$

3. Let  $c_1$  denote the presence of consecutive E's in the arrangement. Likewise,  $c_2, c_3, c_4$ , and  $c_5$  are defined for consecutive N's, O's, R's, and S's, respectively.

$$(a) N = (14!)/(2!)^5$$

$$N(c_1) = (13!)/(2!)^4; S_1 = \binom{5}{1}[(13!)/(2!)^4]$$

$$N(c_1c_2) = (12!)/(2!)^3; S_2 = \binom{5}{2}[(12!)/(2!)^3]$$

$$N(c_1c_2c_3) = (11!)/(2!)^2; S_3 = \binom{5}{3}[(11!)/(2!)^2]$$

$$N(c_1c_2c_3c_4) = 10!/2!; S_4 = \binom{5}{4}(10!/2!)$$

$$N(c_1c_2c_3c_4c_5) = 9! = S_5$$

$$N(\bar{c}_1\bar{c}_2\bar{c}_3\bar{c}_4\bar{c}_5) = 1,286,046,720$$

$$(b) E_2 = S_2 - \binom{3}{1}S_3 + \binom{4}{2}S_4 - \binom{5}{3}S_5 = 350,179,200$$

$$(c) L_3 = S_3 - \binom{3}{2}S_4 + \binom{4}{2}S_5 = 74,753,280$$

4. For  $1 \leq i \leq 7$  let  $c_i$  denote the condition that  $i$  is not in the range of  $f$ . Then the number of functions  $f: A \rightarrow B$  where  $|f(A)| = 4$  is  $E_3 = S_3 - \binom{4}{1}S_4 + \binom{5}{2}S_5 - \binom{6}{3}S_6 + \binom{7}{4}S_7 = \binom{7}{3}4^{10} - \binom{4}{1}\binom{7}{4}3^{10} + \binom{5}{2}\binom{7}{5}2^{10} - \binom{6}{3}\binom{7}{6}1^{10} + \binom{7}{4}\binom{7}{7}0^{10} = 28648200$ .

Note: Using Stirling numbers of the second kind the result is  $\binom{7}{4}4!S(10,4) = 28648200$ .

$$L_3 = S_3 - \binom{3}{2}S_4 + \binom{4}{2}S_5 - \binom{5}{2}S_6 + \binom{6}{2}S_7 = \binom{7}{3}4^{10} - \binom{3}{2}\binom{7}{4}3^{10} + \binom{4}{2}\binom{7}{5}2^{10} - \binom{5}{2}\binom{7}{6}1^{10}$$

5. Here  $A = \{1, 2, 3, \dots, 10\}$ ,  $B = \{1, 2, 3, 4\}$ . Using the ideas in the first part (of Exercise 4) for  $|f(A)| = 2$  we find that  $E_2 = 6132$ . For  $|f(A)| \leq 2$  we find that  $L_2 = 6136$ .
6. For  $1 \leq i \leq 10$  let  $c_i$  denote a replacement where card  $i$  is placed in its correct place.

$$N(c_1c_2c_3c_4) = 6!; S_4 = \binom{10}{4}(6!)$$

In like manner,  $S_i = \binom{10}{i}(i!)$  for  $5 \leq i \leq 10$

$$E_4 = S_4 - \binom{5}{1}S_5 + \binom{6}{2}S_6 - \binom{7}{3}S_7 + \binom{8}{4}S_8 - \binom{9}{5}S_9 + \binom{10}{6}S_{10}$$

$$L_4 = S_4 - \binom{4}{3}S_5 + \binom{5}{3}S_6 - \binom{6}{3}S_7 + \binom{7}{3}S_8 - \binom{8}{3}S_9 + \binom{9}{3}S_{10}$$

7. For  $1 \leq i \leq 4$ , let  $c_i$  denote a void in ( $i = 1$ ) clubs, ( $i = 2$ ) diamonds, ( $i = 3$ ) hearts, and ( $i = 4$ ) spades.

$$N(c_i) = \binom{39}{13}, 1 \leq i \leq 4; N(c_i c_j) = \binom{26}{13}, 1 \leq i < j \leq 4; N(c_i c_j c_k) = \binom{13}{13}, 1 \leq i < j < k \leq 4; N(c_1 c_2 c_3 c_4) = 0.$$

$$N(\bar{c}_1\bar{c}_2\bar{c}_3\bar{c}_4) = \binom{52}{13} - \binom{4}{1}\binom{39}{13} + \binom{4}{2}\binom{26}{13} - \binom{4}{3}\binom{13}{13}$$

The probability that the 13 cards include at least one card from each suit is  $N(\bar{c}_1\bar{c}_2\bar{c}_3\bar{c}_4)/\binom{52}{13}$ .

(b)  $E_1 = S_1 - \binom{2}{1}S_2 + \binom{3}{2}S_3 - \binom{4}{3}S_4 = \binom{4}{1}\binom{39}{13} - 2\binom{4}{2}\binom{26}{13} + 3\binom{4}{3}\binom{13}{13} - 0$ . The probability of exactly one void is  $E_1/\binom{52}{13}$ .

(c)  $E_2 = S_2 - \binom{3}{1}S_3 = \binom{4}{2}\binom{26}{13} - 3\binom{4}{3}\binom{13}{13}$ . The probability of exactly two voids is  $E_2/\binom{52}{13}$ .

8. (b)  $E_{t-1} = S_{t-1} - tS_t$ ;  $L_{t-1} = L_t + E_{t-1}$

(c)  $L_{t-1} = L_t + E_{t-1} = S_t + S_{t-1} - tS_t = S_{t-1} - (t-1)S_t = S_{t-1} - \binom{t-1}{t-2}S_t$

(d)  $L_m = L_{m+1} + E_m$

(e)  $L_t = S_t$

$$L_{t-1} = S_{t-1} - \binom{t-1}{t-2}S_t$$

Assume  $L_{k+1} = S_{k+1} - \binom{k+1}{k}S_{k+2} + \binom{k+2}{k}S_{k+3} - \dots + (-1)^{t-k-1}\binom{t-1}{k}S_t$

$$L_k = L_{k+1} + E_k = [S_{k+1} - \binom{k+1}{k}S_{k+2} + \binom{k+2}{k}S_{k+3} - \dots +$$

$$(-1)^{t-k-1}\binom{t-1}{k}S_t] + [S_k - \binom{k+1}{1}S_{k+1} + \binom{k+2}{2}S_{k+2} - \dots + (-1)^{t-k}\binom{t}{t-k}S_t]$$

For  $1 \leq r \leq t-k$ , the coefficient of  $S_{k+r}$  is  $(-1)^{r-1}\binom{k+r-1}{k} + (-1)^r\binom{k+r}{r} = (-1)^{r-1}[(k+r-1)!/(k!(r-1)!) - (k+r)!/(k!r!)] = (-1)^{r-1}[r(k+r+1)! - (k+r)!]/(k!r!) = (-1)^{r-1}[k+r-1](-k)!/(k!r!) = (-1)^r\binom{k+r-1}{k-1}$ .

Consequently,  $L_k = S_k - \binom{k}{k-1}S_{k+1} + \binom{k+1}{k-1}S_{k+2} - \dots + (-1)^{t-k}\binom{t-1}{k-1}S_t$ .

### Section 8.3

1. For  $1 \leq i \leq 5$  let  $c_i$  be the condition that  $2i$  is in position  $2i$ .

$$N = 10!; N(c_i) = 9!, 1 \leq i \leq 5; N(c_i c_j) = 8!, 1 \leq i < j \leq 5; \dots; N(c_1 c_2 c_3 c_4 c_5) = 5!$$

$$N(\bar{c}_1 \bar{c}_2 \bar{c}_3 \bar{c}_4 \bar{c}_5) = 10! - \binom{5}{1}9! + \binom{5}{2}8! - \binom{5}{3}7! + \binom{5}{4}6! - \binom{5}{5}5!$$

2. (a) There are only two derangements with this property: 23154 and 31254.

(b) Here there are four such derangements:

(i) 231546

(ii) 231645

(iii) 312546

(iv) 312645

3. The number of derangements for 1,2,3,4,5 is  $5![1 - 1 + (1/2!) - (1/3!) + (1/4!) - (1/5!)] = 5![(1/2!) - (1/3!) + (1/4!) - (1/5!)] = (5)(4)(3) - (5)(4) + 5 - 1 = 60 - 20 + 5 - 1 = 44$ .

4. There are  $7! = 5040$  permutations of 1,2,3,4,5,6,7. Among these there are  $7![1 - 1 + (1/2!) - (1/3!) + (1/4!) - (1/5!) + (1/6!) - (1/7!)] = 1854$  derangements. Consequently, we have  $5040 - 1854 = 3186$  permutations of 1,2,3,4,5,6,7 that are not derangements.

5. (a)  $7! - d_7$  ( $d_7 \doteq (7!)e^{-1}$ );

(b)  $d_{26} \doteq (26!)e^{-1}$

6. (a) There are  $(d_4)^2 = 9^2 = 81$  such derangements.  
 (b) In this case we get  $(4!)^2 = 24^2 = 576$  derangements.
7. Let  $n = 5 + m$ . Then  $11,660 = d_5 \cdot d_m = 44(d_m)$ , and so  $d_m = 265 = d_6$ . Consequently,  $n = 11$ .
8. (a)  $(4!)d_4 \doteq (4!)^2 e^{-1}$       (b) and (c)  $(2)(3^2)(6)/[(4!)^2 e^{-1}]$
9.  $(10!)d_{10} \doteq (10!)^2(e^{-1})$
10. (a) (i)  $d_n/n!$       (ii)  $n(d_{n-1})/n!$       (iii)  $1 - (d_n/n!)$       (iv)  $[\binom{n}{r}d_{n-r}]/n!$   
 (b) (i)  $e^{-1}$       (ii)  $e^{-1}$       (iii)  $1 - e^{-1}$       (iv)  $(1/r!)e^{-1}$
11. (a)  $(d_{10})^2$   
 (b) For  $1 \leq i \leq 10$  let  $c_i$  denote that woman  $i$  gets back both of her possessions.  
 $N = (10!)^2$ ;  $N(c_i) = (9!)^2$ ,  $1 \leq i \leq 10$ ;  $N(c_i c_j) = (8!)^2$ ,  $1 \leq i < j \leq 10$ ; etc.  
 $N(\bar{c}_1 \bar{c}_2 \dots \bar{c}_{10}) = (10!)^2 - \binom{10}{1}(9!)^2 + \binom{10}{2}(8!)^2 - \dots + (-1)^{10} \binom{10}{0}(0!)^2$ .

12. (a)  $(12!)d_{12}$       (b)  $(12!)\binom{12}{6}d_6$

13. For each  $n \in \mathbf{Z}^+$ ,  $n!$  counts the total number of permutations of  $1, 2, 3, \dots, n$ . Each such permutation will have  $k$  elements that are deranged (that is, there are  $k$  elements  $x_1, x_2, \dots, x_k$  in  $\{1, 2, 3, \dots, n\}$  where  $x_1$  is *not* in position  $x_1$ ,  $x_2$  is *not* in position  $x_2$ , ..., and  $x_k$  is *not* in position  $x_k$ ) and  $n - k$  elements are fixed (that is, the  $n - k$  elements  $y_1, y_2, \dots, y_{n-k}$  in  $\{1, 2, 3, \dots, n\} - \{x_1, x_2, \dots, x_k\}$  are such that  $y_1$  is in position  $y_1$ ,  $y_2$  is in position  $y_2$ , ..., and  $y_{n-k}$  is in position  $y_{n-k}$ ). The  $n - k$  fixed elements can be chosen in  $\binom{n}{n-k}$  ways and the remaining  $k$  elements can then be permuted (that is, deranged) in  $d_k$  ways. Hence there are  $\binom{n}{n-k}d_k = \binom{n}{k}d_k$  permutations of  $1, 2, 3, \dots, n$  with  $n - k$  fixed elements (and  $k$  deranged elements). As  $k$  varies from 0 to  $n$  we count all of the  $n!$  permutations of  $1, 2, 3, \dots, n$  according to the number  $k$  of deranged elements.

Consequently,

$$n! = \binom{n}{0}d_0 + \binom{n}{1}d_1 + \binom{n}{2}d_2 + \dots + \binom{n}{n}d_n = \sum_{k=0}^n \binom{n}{k}d_k.$$

14. (a) For  $1 \leq i \leq n - 1$  let  $c_i$  denote the occurrence of the pattern  $i(i + 1)$  in the linear arrangement

$$N(c_i) = (n - 1)!, \quad 1 \leq i \leq n - 1$$

$$N(c_i c_j) = (n - 2)!, \quad 1 \leq i < j \leq n - 1$$

$$N(c_i c_j c_k) = (n - 3)!, \quad 1 \leq i < j < k \leq n - 1, \dots,$$

$$N(c_1 c_2 \dots c_{n-1}) = (n - (n - 1))!$$

$$N(\bar{c}_1 \bar{c}_2 \dots \bar{c}_{n-1}) = n! - \binom{n-1}{1}(n-1)! + \binom{n-1}{2}(n-2)! - \binom{n-1}{3}(n-3)! + \dots + (-1)^k \binom{n-1}{k}(n-k)! + \dots + (-1)^{n-1} \binom{n-1}{n-1}(n-(n-1))!$$

$$(b) \quad d_n + d_{n-1} = [n! - \binom{n}{1}(n-1)! + \binom{n}{2}(n-2)! - \dots + (-1)^n \binom{n}{n}(n-n)!] + [(n-1)! - \binom{n-1}{1}(n-2)! + \binom{n-1}{2}(n-3)! - \dots + (-1)^{n-1} \binom{n-1}{n-1}((n-1)-(n-1))!]$$

The coefficient of  $(n-k)!$  in  $d_n + d_{n-1}$  is  $(-1)^k \binom{n}{k} + (-1)^{k-1} \binom{n-1}{k-1} = (-1)^{k-1} [((n-1)! / [(k-1)!(n-k)!]) - [n! / [k!(n-k)!]]] = (-1)^{k-1} [(k(n-1)! - n!] / [k!(n-k)!]] = (-1)^{k-1} (n-1)! [(k-n) / [k!(n-k)!]] = (-1)^k (n-1)! / [k!(n-k-1)!] = (-1)^k \binom{n-1}{k}.$

$$15. \quad \binom{n}{0}(n-1)! - \binom{n}{1}(n-2)! + \binom{n}{2}(n-3)! - \dots + (-1)^{n-1} \binom{n}{n-1}(0!) + (-1)^n \binom{n}{n}$$

$$16. \quad (a) \quad (11,088)/(10!) \doteq 0.003 \qquad (b) \quad (13,264)/(10!) \doteq 0.004$$

### Sections 8.4 and 8.5

- These results follow by counting the possible locations for the desired numbers of rooks on each chessboard.
- Consider a chessboard made up of 10 squares arranged in a diagonal so that in each row and column there is only one square.
- (a)  $\binom{8}{0} + \binom{8}{1}8x + \binom{8}{2}(8 \cdot 7)x^2 + \binom{8}{3}(8 \cdot 7 \cdot 6)x^3 + \binom{8}{4}(8 \cdot 7 \cdot 6 \cdot 5)x^4 + \dots + \binom{8}{8}(8!)x^8 = \sum_{i=0}^8 \binom{8}{i}P(8, i)x^i.$  (b)  $\sum_{i=0}^n \binom{n}{i}P(n, i)x^i$
- $r(C_1, x) = 1 + 4x + 3x^2 = r(C_2, x)$
- (a) (i)  $(1 + 2x)^3$  (ii)  $1 + 8x + 14x^2 + 4x^3$   
(iii)  $1 + 9x + 25x^2 + 21x^3$  (iv)  $1 + 8x + 16x^2 + 7x^3$   
(b) If the board  $C$  consists of  $n$  steps, and each step has  $k$  blocks, then  $r(C, x) = (1 + kx)^n.$
- (a) Select the  $k$  row positions in  $\binom{m}{k}$  ways. As we go from row 1 to row 2 to ... to row  $m$ , for the first row containing a rook there are  $n$  column choices. For the second such row there are  $n-1$  column choices, ..., and for the row containing the  $k$ -th rook there are  $n-k+1$  column choices. Hence we can arrange the  $k$  identical nontaking rooks on  $C$  in  $\binom{m}{k}(n)(n-1)\dots(n-k+1) = (k!)\binom{m}{k}\binom{n}{k}$  ways.  
(b)  $r(C, x) = 1 + (mn)x + \binom{m}{2}(n)(n-1)x^2 + \binom{m}{3}(n)(n-1)(n-2)x^3 + \dots + \binom{m}{m}(n)(n-1)(n-2)\dots(n-m+1)x^m = \binom{m}{0} + \binom{m}{1}nx + \binom{m}{2}(n)(n-1)x^2 + \binom{m}{3}(n)(n-1)(n-2)x^3 + \dots + \binom{m}{m}(n)(n-1)(n-2)\dots(n-m+1)x^m = \sum_{i=0}^m \binom{m}{i}(n)(n-1)(n-2)\dots(n-i+1)x^i = \sum_{i=0}^m \binom{m}{i} \frac{n!}{(n-i)!} x^i.$

7.

	Java	C++	VHDL	Perl	SQL
(1) Jeanne					
(2) Charles					
(3) Todd					
(4) Paul					
(5) Sandra					

$$r(C, x) = (1 + 4x + 3x^2)(1 + 4x + 2x^2) = 1 + 8x + 21x^2 + 20x^3 + 6x^4$$

For  $1 \leq i \leq 5$  let  $c_i$  be the condition that an assignment is made with person (i) assigned to a language he or she wishes to avoid.

$$N(\bar{c}_1 \bar{c}_2 \bar{c}_3 \bar{c}_4 \bar{c}_5) = 5! - 8(4!) + 21(3!) - 20(2!) + 6(1!) = 20.$$

8. The factor  $(6!)$  is needed because we are counting ordered sequences.

9. (a) 20                      (b) 3/10

10.

	1	5	2	4	6	3
1						
5						
3						
4						
2						
6						

$$r(C, x) = (1 + 4x + 2x^2) \cdot (1 + 3x + x^2) \cdot (1 + x) = 1 + 8x + 22x^2 + 25x^3 + 12x^4 + 2x^5.$$

For  $1 \leq i \leq 6$ , let  $c_i$  denote the condition where, having rolled the dice six times, all six values occur on both the red die and green die, but  $i$  on the red die is paired with one of the forbidden numbers on the green die.

$$N(\bar{c}_1 \bar{c}_2 \dots \bar{c}_6) = [6! - 8(5!) + 22(4!) - 25(3!) + 12(2!) - 2(1!) + 0(0!)] = 160.$$

The probability that every value came up on both the red die and the green die is  $(6!)(160)/[(28)^6] \doteq 0.00024$ .

11.

	M <sub>1</sub>	M <sub>3</sub>	M <sub>6</sub>	M <sub>2</sub>	M <sub>4</sub>	M <sub>5</sub>
W <sub>1</sub>						
W <sub>3</sub>						
W <sub>2</sub>						
W <sub>4</sub>						

$$r(C, x) = (1 + 5x + 4x^2)(1 + 4x + 3x^2) = 1 + 9x + 27x^2 + 31x^3 + 12x^4.$$

For  $1 \leq i \leq 4$ , let  $c_i$  denote the condition where each of the four women has been matched with one of the six men but woman  $i$  is paired with an incompatible partner. Then

$$N(\bar{c}_1 \bar{c}_2 \bar{c}_3 \bar{c}_4) = (6 \cdot 5 \cdot 4 \cdot 3) - 9(5 \cdot 4 \cdot 3) + 27(4 \cdot 3) - 31(3) + 12 = 63.$$

12. Consider the chessboard  $C$  of shaded squares.

	u	v	w	x	y	z
1		■	■			
2	■					
3				■		
4		■		■	■	
5						

Here  $r(C, x) = 1 + 8x + 20x^2 + 17x^3 + 4x^4$ . For any one-to-one function  $f : A \rightarrow B$ , let  $c_1, c_2, c_3, c_4$  denote the conditions:

$$c_1 : f(1) = v \text{ or } w$$

$$c_3 : f(3) = x$$

$$c_2 : f(2) = u \text{ or } w$$

$$c_4 : f(4) = v, x, \text{ or } y$$

The answer to this problem is  $N(\bar{c}_1\bar{c}_2\bar{c}_3\bar{c}_4) = 6! - 8(5!) + 20(4!) - 17(3!) + 4(2!) = 146$ . So there are 146 one-to-one functions  $f : A \rightarrow B$  where

$$f(1) \neq v, w$$

$$f(3) \neq x$$

$$f(2) \neq u, w$$

$$f(4) \neq v, x, y.$$

### Supplementary Exercises

1. We need only consider the divisors 2, 3, and 5. Let  $c_1$  denote divisibility by 2,  $c_2$  divisibility by 3, and  $c_3$  divisibility by 5.

$$N = 500; N(c_1) = \lfloor 500/2 \rfloor = 250; N(c_2) = \lfloor 500/3 \rfloor = 166; N(c_3) = \lfloor 500/5 \rfloor = 100; N(c_1c_2) = \lfloor 500/6 \rfloor = 83; N(c_1c_3) = \lfloor 500/10 \rfloor = 50; N(c_2c_3) = \lfloor 500/15 \rfloor = 33; N(c_1c_2c_3) = \lfloor 500/30 \rfloor = 16.$$

$$N(\bar{c}_1\bar{c}_2\bar{c}_3) = 500 - (250 + 166 + 100) + (83 + 50 + 33) - 16 = 134.$$

2. Let  $n = n_1n_2n_3n_4n_5n_6$ , where  $0 \leq n_i \leq 9$  for  $1 \leq i \leq 6$ . We want  $n_1 + n_2 + n_3 + n_4 + n_5 + n_6 \leq 37$ . Hence the answer to this problem is the number of nonnegative integer solutions for

$$n_1 + n_2 + n_3 + n_4 + n_5 + n_6 + n_7 = 37,$$

where  $0 \leq n_i \leq 9$  for  $1 \leq i \leq 6$ , and  $0 \leq n_7 (\leq 37)$ .

For  $1 \leq i \leq 6$  define the condition  $c_i$  as follows:  $n_1, n_2, n_3, n_4, n_5, n_6, n_7$  is a nonnegative integer solution for

$$n_1 + n_2 + \dots + n_7 = 37$$

but  $n_i > 9$  (or  $n_i \geq 10$ ).

$$S_0 = N = \binom{7+37-1}{37} = \binom{43}{37}$$

$N(c_1)$  is the number of nonnegative integer solutions for  $x_1 + x_2 + x_3 + \dots + x_7 = 27$  — here  $x_1 + 10 = n_1$ , and  $x_i = n_i$  for  $2 \leq i \leq 7$ . So  $N(c_1) = \binom{7+27-1}{27} = \binom{33}{27}$  and  $S_1 = \binom{6}{1} \binom{33}{27}$ .

$N(c_1c_2)$  is the number of nonnegative integer solutions for  $y_1 + y_2 + y_3 + \dots + y_7 = 17$  — here  $y_1 + 10 = n_1$ ,  $y_2 + 10 = n_2$ , and  $y_i = n_i$  for  $3 \leq i \leq 7$ . This is  $\binom{7+17-1}{17} = \binom{23}{17}$ , and so  $S_2 = \binom{6}{2} \binom{23}{17}$ .

$N(c_1c_2c_3)$  counts the number of nonnegative integer solutions for  $z_1 + z_2 + z_3 + \dots + z_7 = 7$ , where  $z_i + 10 = n_i$  for  $1 \leq i \leq 3$ , and  $z_i = n_i$  for  $4 \leq i \leq 7$ . So  $N(c_1c_2c_3) = \binom{7+7-1}{7} = \binom{13}{7}$  and  $S_3 = \binom{6}{3} \binom{13}{7}$ .

Since  $S_4 = S_5 = S_6 = 0$ , the answer to this problem is

$$N(\bar{c}_1\bar{c}_2\bar{c}_3\dots\bar{c}_6) = S_0 - S_1 + S_2 - S_3 + S_4 - S_5 + S_6 = \binom{43}{37} - \binom{6}{1} \binom{33}{27} + \binom{6}{2} \binom{23}{17} - \binom{6}{3} \binom{13}{7} = 930, 931.$$

3. For each distribution of the 24 balls (among the four shelves) there are  $(24!)/(6!)^4$  possible arrangements. Hence we need to know in how many ways the boys can distribute the balls for the given restrictions. This is the number of integer solutions for

$$x_1 + x_2 + x_3 + x_4 = 24,$$

where  $2 \leq x_i \leq 7$  for all  $1 \leq i \leq 4$ .

This equals the number of integer solutions for

$$y_1 + y_2 + y_3 + y_4 = 16,$$

where  $0 \leq y_i \leq 5$  for all  $1 \leq i \leq 4$ . [Here  $y_i + 2 = x_i$  for each  $1 \leq i \leq 4$ .]

For  $1 \leq i \leq 4$  define  $c_i$  to be the condition that  $y_1, y_2, y_3, y_4$  is a solution of

$$y_1 + y_2 + y_3 + y_4 = 16,$$

where  $y_i > 5$  (or  $y_i \geq 6$ ) and  $y_j \geq 0$  for all  $1 \leq j \leq 4$ ,  $j \neq i$ . Then, for example,  $N(c_1)$  is the number of nonnegative integer solutions for

$$w_1 + w_2 + w_3 + w_4 = 10.$$

[Here  $w_1 + 6 = y_1$  and  $w_i = y_i$  for  $i = 2, 3, 4$ .] So  $N(c_1) = \binom{4+10-1}{10} = \binom{13}{10}$  and  $S_1 = \binom{4}{1} \binom{13}{10}$ .

Similar arguments show us that  $N(c_1c_2) = \binom{4+4-1}{4} = \binom{7}{4}$  and  $S_2 = \binom{4}{2} \binom{7}{4}$ ; and  $S_3 = S_4 = 0$ .

Therefore the number of distributions for the given restrictions is

$$N(\bar{c}_1\bar{c}_2\bar{c}_3\bar{c}_4) = \binom{19}{16} - \binom{4}{1} \binom{13}{10} + \binom{4}{2} \binom{7}{4},$$

and Joseph and Jeffrey can arrange the 24 balls in

$$[(24!)/(6!)^4] \left[ \binom{19}{16} - \binom{4}{1} \binom{13}{10} + \binom{4}{2} \binom{7}{4} \right]$$

ways.

4. Here  $S = \{1, 2, 3, \dots, 1000\}$  and  $N = S_0 = 1000$ . We define the conditions  $c_1, c_2, c_3$  on the elements of  $S$  as follows:

- $c_1$ :  $n \in S$  and  $n$  is a perfect square;  
 $c_2$ :  $n \in S$  and  $n$  is a perfect cube; and  
 $c_3$ :  $n \in S$  and  $n$  is a perfect fourth power.

Then  $N(c_1) = 31$ ,  $N(c_2) = 10$ ,  $N(c_3) = 5$ ,  
 $N(c_1c_2) = 3$ ,  $N(c_1c_3) = N(c_2c_3) = 1$ , and  
 $N(c_1c_2c_3) = 1$ . Consequently,  
 $N(\bar{c}_1\bar{c}_2\bar{c}_3) = S_0 - S_1 + S_2 - S_3 =$   
 $1000 - [31 + 10 + 5] + [3 + 5 + 1] - 1 = 1000 - 46 + 9 - 1 = 962$ .

5. Let  $c_i$  denote the occurrence of the pattern  $i(i+1)$  for  $1 \leq i \leq 7$ .

The occurrence of the pattern 81 is denoted by  $c_8$ .

For  $1 \leq i \leq 8$ ,  $N(c_i) = 7!$ ;  $N(c_i c_j) = 6!$ ,  $1 \leq i < j \leq 8$ ; etc.

$$N(\bar{c}_1\bar{c}_2 \dots \bar{c}_8) = 8! - \binom{8}{1}7! + \binom{8}{2}6! - \binom{8}{3}5! + \dots + (-1)^7 \binom{8}{7}1! = 14832.$$

6. (a) Label the walls of the room (clockwise) as 1,2,3,4, and 5. Let  $c_1$  denote that walls 1,2 have the same color. Condition  $c_2$  denotes that walls 2,3 have the same color. In a similar way we define conditions  $c_3$  and  $c_4$ , while  $c_5$  denotes that walls 5,1 have the same color.

$$N = k^5; N(c_i) = k^4, 1 \leq i \leq 5; N(c_i c_j) = k^3, 1 \leq i < j \leq 5;$$

$$N(c_i c_j c_\ell) = k^2, 1 \leq i < j < \ell \leq 5;$$

$$N(c_i c_j c_\ell c_m) = k, 1 \leq i < j < \ell < m \leq 5; \text{ and } N(c_1 c_2 c_3 c_4 c_5) = k.$$

$$\text{So } N(\bar{c}_1\bar{c}_2\bar{c}_3\bar{c}_4\bar{c}_5) = k^5 - \binom{5}{1}k^4 + \binom{5}{2}k^3 - \binom{5}{3}k^2 + \binom{5}{4}k - \binom{5}{5}k.$$

(b) For  $k = 1, 2$  this result is 0. For  $k = 3$  the result is 30.

7. For  $1 \leq i \leq 10$ , let  $c_i$  denote the condition where student  $i$  occupies the same chair before and after the break. Then the answer to this exercise is  $N(\bar{c}_1\bar{c}_2\bar{c}_3 \dots \bar{c}_{10}) = S_0 - S_1 + S_2 - S_3 + \dots + S_{10}$ .

$$\text{Here } S_0 = \binom{14}{10}10! = (14)(13)(12) \dots (5).$$

$N(c_1) = \binom{13}{9}9! = (13)(12) \dots (5)$ , and by symmetry  $N(c_i) = N(c_1)$  for  $2 \leq i \leq 10$ . So  
 $S_1 = \binom{10}{1} \binom{13}{9}9!$

$$N(c_1 c_2) = \binom{12}{8}8! \text{ and } S_2 = \binom{10}{2} \binom{12}{8}8!$$

In general for  $0 \leq k \leq 10$ ,

$$S_k = \binom{10}{k} \binom{14-k}{10-k} (10-k)!$$

$$\text{and } N(\bar{c}_1 \bar{c}_2 \bar{c}_3 \dots \bar{c}_{10}) = \sum_{k=0}^{10} (-1)^k S_k = \sum_{k=0}^{10} (-1)^k \binom{10}{k} \binom{14-k}{10-k} (10-k)! = 1,764,651,461.$$

$$8. \quad E_m = S_m - \binom{m+1}{m} S_{m+1} + \binom{m+2}{m} S_{m+2} - \dots + (-1)^{i-m} \binom{i}{m} S_i - \dots + (-1)^{n-m} \binom{n}{m} S_n.$$

$S_i = \binom{n}{i} \binom{s}{r} \binom{s-r}{r} \binom{s-2r}{r} \dots \binom{s-(i-1)r}{r} (n-i)^{s-ir}$ , where  $\binom{n}{i}$  is for the selection of the  $i$  containers (from the  $n$  possible distinct containers), each of which will contain exactly  $r$  elements. The product  $\binom{s}{r} \binom{s-r}{r} \dots \binom{s-(i-1)r}{r}$  is for the selection of  $r$  distinct objects for each of the  $i$  distinct containers. Finally,  $(n-i)^{s-ir}$  appears because for each of the remaining  $s-ir$  objects there are  $n-i$  containers to select from.

$$\begin{aligned} \binom{s}{r} \binom{s-r}{r} \binom{s-2r}{r} \dots \binom{s-(i-1)r}{r} &= \frac{s!}{(s-ir)!(r!)^i} \\ (-1)^{i-m} \binom{i}{m} S_i &= (-1)^{i-m} \binom{i}{m} \binom{n}{i} \frac{s!}{(s-ir)!(r!)^i} (n-i)^{s-ir} \\ &= (-1)^{i-m} \frac{i!}{m!(i-m)!} \frac{n!}{i!(n-i)!} \frac{s!}{(s-ir)!(r!)^i} (n-i)^{s-ir} \\ &= (-1)^{-m} \frac{n!s!}{m!} [(-1)^i (n-i)^{s-ir}] / [(i-m)!(n-i)!(s-ir)!(r!)^i] \end{aligned}$$

$$\text{and } E_m = (-1)^m \frac{n!s!}{m!} \sum_{i=m}^n (-1)^i \frac{(n-i)^{s-ir}}{(i-m)!(n-i)!(s-ir)!(r!)^i}$$

$$9. \quad \text{The total number of arrangements is } T = (13!)/[(2!)^5].$$

$$(a) \quad S_3 = \binom{5}{3} [(10!)/(2!)^2]$$

$$S_4 = \binom{5}{4} [(9!)/(2!)]$$

$$S_5 = \binom{5}{5} (8!)$$

$$E_3 = [S_3 - \binom{4}{1} S_4 + \binom{5}{2} S_5] / T$$

$$(b) \quad E_4 = [S_4 - \binom{5}{1} S_5] \quad E_5 = S_5$$

$$\text{The answer is } [T - (E_4 + E_5)] / T.$$

10. Let  $c_i$  denote that the arrangement contains a consecutive quadruple of ( $i=1$ )  $w$ 's; ( $i=2$ )  $x$ 's; ( $i=3$ )  $y$ 's; and ( $i=4$ )  $z$ 's.

$$N = 16!/(4!)^4; \quad N(c_i) = 13!/(4!)^3, \quad 1 \leq i \leq 4; \quad N(c_i c_j) = 10!/(4!)^2, \quad 1 \leq i < j \leq 4; \quad N(c_i c_j c_k) = 7!/(4!), \quad 1 \leq i < j < k \leq 4; \quad N(c_1 c_2 c_3 c_4) = 4!$$

$$N(\bar{c}_1 \bar{c}_2 \bar{c}_3 \bar{c}_4) = [16!/(4!)^4] - \binom{4}{1} [13!/(4!)^3] + \binom{4}{2} [10!/(4!)^2] - \binom{4}{3} (7!/4!) + \binom{4}{4} (4!)$$

$$11. \quad (a) \quad \binom{n-m}{r-m} = \binom{n-m}{n-r}$$

(b) Let  $A = \{x_1, x_2, \dots, x_m, y_{m+1}, \dots, y_n\}$ . For  $1 \leq i \leq m$  let  $c_i$  denote that  $r$  elements are selected from  $A$  with  $r \geq m$  and  $x_i$  is not in the selection.

$$N = \binom{n}{r}; \quad N(c_i) = \binom{n-1}{r}, \quad 1 \leq i \leq m; \quad S_1 = \binom{m}{1} \binom{n-1}{r}$$

$$N(c_i c_j) = \binom{n-2}{r}, 1 \leq i < j \leq m; S_2 = \binom{m}{2} \binom{n-2}{r}, \text{ etc.}$$

$$\binom{n-m}{n-r} = N(\bar{c}_1 \bar{c}_2 \dots \bar{c}_m) = \sum_{i=0}^m (-1)^i \binom{m}{i} \binom{n-i}{r}.$$

12. (a) Define conditions  $c_i, 1 \leq i \leq 5$ , as follows:

$c_1$ : a and b have the same color.

$c_2$ : b and c have the same color.

$c_3$ : b and e have the same color.

$c_4$ : c and e have the same color.

$c_5$ : c and d have the same color.

$$N = \lambda^5; N(c_i) = \lambda^4, 1 \leq i \leq 5; N(c_i c_j) = \lambda^3, 1 \leq i < j \leq 5;$$

$$N(c_2 c_3 c_4) = \lambda^3, N(c_i c_j c_k) = \lambda^2 \text{ for all other } 1 \leq i < j < k \leq 5;$$

$$N(c_1 c_2 c_3 c_4) = N(c_2 c_3 c_4 c_5) = \lambda^2, N(c_1 c_2 c_3 c_5) = N(c_1 c_2 c_4 c_5) =$$

$$N(c_1 c_3 c_4 c_5) = \lambda; N(c_1 c_2 c_3 c_4 c_5) = \lambda.$$

$$N(\bar{c}_1 \bar{c}_2 \bar{c}_3 \bar{c}_4 \bar{c}_5) = \lambda^5 - 5\lambda^4 + 10\lambda^3 - (\lambda^3 + 9\lambda^2) + (2\lambda^2 + 3\lambda) - \lambda = \lambda^5 - 5\lambda^4 + 9\lambda^3 - 7\lambda^2 + 2\lambda.$$

For  $\lambda = 1, 2$ , this result is 0. When  $\lambda = 3$  the result is positive and so the chromatic number is 3.

(b) Draw a graph with a vertex for each room. If two rooms share a common doorway draw an edge connecting their corresponding vertices.

The result is the graph in part (a) and the answer is  $6^5 - 5(6^4) + 9(6^3) - 7(6^2) + 2(6) = 3000$ .

13. Consider the derangements of the symbols L, A, P<sub>1</sub>, T, O, P<sub>2</sub>. There are  $d_6$  such arrangements.

Of these there are

(i)  $d_4$  arrangements where P<sub>2</sub> is in position 3 and P<sub>1</sub> is in position 6;

(ii)  $d_5$  arrangements where P<sub>1</sub> is in position 6 and P<sub>2</sub> is not in position 3; and,

(iii)  $d_5$  arrangements where P<sub>2</sub> is in position 3 and P<sub>1</sub> is not in position 6.

There are  $d_6 - 2d_5 - d_4$  such arrangements of L, A, P<sub>1</sub>, T, O, P<sub>2</sub>. Hence there are  $(1/2)[d_6 - 2d_5 - d_4] = (1/2)[265 - 2(44) - 9] = 84$  ways to arrange the letters in LAPTOP so that none of L, A, T, O is in its original position and P is not in the third or sixth position. [Why the 1/2? Because we do not distinguish arrangements such as P<sub>1</sub> L A P<sub>2</sub> T O and P<sub>2</sub> L A P<sub>1</sub> T O.]

14. Proof: Let  $n = qm$  where  $q$  is prime and  $m > 1$ . Then  $\phi(n) = n \prod_{p \text{ prime}}^{p|n} (1 - (1/p)) \leq n(1 - (1/q))$ . Consequently,  $n - 1 = \phi(n) \leq n - (n/q)$ , or  $1 \geq n/q = m > 1$  — a contradiction!

15.

$$(a) S_1 = \{1, 5, 7, 11, 13, 17\}$$

$$S_3 = \{3, 15\}$$

$$S_9 = \{9\}$$

$$S_2 = \{2, 4, 8, 10, 14, 16\}$$

$$S_6 = \{6, 12\}$$

$$S_{18} = \{18\}$$

$$\begin{array}{lll} \text{(b)} & |S_1| = 6 = \phi(18) & |S_3| = 2 = \phi(6) & |S_9| = 1 = \phi(2) \\ & |S_2| = 6 = \phi(9) & |S_6| = 2 = \phi(3) & |S_{18}| = 1 = \phi(1) \end{array}$$

16. (a) Let  $k \in \mathbf{Z}^+, 1 \leq k \leq m$ . Then  $\gcd(k, m) = d \leq m$ , for some  $d \in D_m$ . If  $k \in S_{d_1}, S_{d_2}$  then  $d_1 = \gcd(k, m) = d_2$ . So the collection  $S_d, d \in D_m$ , provides a partition of  $\{1, 2, 3, 4, \dots, m-1, m\}$ .

(b) Recall that  $\gcd(n, m) = d$  if and only if  $\gcd(n/d, m/d) = 1$ , so  $|S_d| = |\{n|0 < n \leq m \text{ and } \gcd(n, m) = d\}| = |\{n|0 < n/d \leq m/d \text{ and } \gcd(n/d, m/d) = 1\}| = \phi(m/d)$ .

17. Proof:

(a) If  $n$  is even then by the Fundamental Theorem of Arithmetic (Theorem 4.11) we may write  $n = 2^k m$ , where  $k \geq 1$  and  $m$  is odd. Then  $2n = 2^{k+1} m$  and  $\phi(2n) = (2^{k+1})(1 - \frac{1}{2})\phi(m) = 2^k \phi(m) = 2(2^k)(\frac{1}{2})\phi(m) = 2[2^k(1 - \frac{1}{2})\phi(m)] = 2[\phi(2^k m)] = 2\phi(n)$ .

(b) When  $n$  is odd we find that  $\phi(2n) = (2n)(1 - \frac{1}{2}) \prod_{p|n} (1 - \frac{1}{p})$ , where the product is taken over all (odd) primes dividing  $n$ . (If  $n = 1$  then  $\prod_{p|n} (1 - \frac{1}{p})$  is 1.) But  $(2n)(1 - \frac{1}{2}) \prod_{p|n} (1 - \frac{1}{p}) =$

$$n \prod_{p|n} (1 - \frac{1}{p}) = \phi(n).$$

18. Proof:

Let  $a = p_1^{m_1} p_2^{m_2} \dots p_t^{m_t}$  and  $b = p_1^{n_1} p_2^{n_2} \dots p_t^{n_t}$ , where  $p_1, p_2, \dots, p_t$  are distinct primes, and  $m_1, m_2, \dots, m_t, n_1, n_2, \dots, n_t \in \mathbf{N}$ . Then  $c = \gcd(a, b) = p_1^{\min\{m_1, n_1\}} p_2^{\min\{m_2, n_2\}} \dots p_t^{\min\{m_t, n_t\}}$ .

So  $\phi(ab)\phi(c) =$

$$[p_1^{m_1+n_1} p_2^{m_2+n_2} \dots p_t^{m_t+n_t} (1 - \frac{1}{p_1})(1 - \frac{1}{p_2}) \dots (1 - \frac{1}{p_t})] \prod_{\substack{1 \leq i \leq t \\ \min\{m_i, n_i\} \neq 0}} p_i^{\min\{m_i, n_i\}} (1 - \frac{1}{p_i}) \text{ and}$$

$$\phi(a)\phi(b)c = \left[ \prod_{\substack{1 \leq i \leq t \\ m_i \neq 0}} p_i^{m_i} (1 - \frac{1}{p_i}) \right] \left[ \prod_{\substack{1 \leq i \leq t \\ n_i \neq 0}} p_i^{n_i} (1 - \frac{1}{p_i}) \right] \left[ \prod_{1 \leq i \leq t} p_i^{\min\{m_i, n_i\}} \right].$$

For  $1 \leq i \leq t$  we shall verify that we get the same factors involving the prime  $p_i$  for both  $\phi(ab)\phi(c)$  and  $\phi(a)\phi(b)c$ . This will then establish that  $\phi(ab)\phi(c) = \phi(a)\phi(b)c$ . We consider the following cases:

(1)  $\min\{m_i, n_i\} = 0$ : Say  $0 = m_i < n_i$ . (The same type of argument applies if  $0 = n_i < m_i$ .) Then in  $\phi(ab)\phi(c)$  we find  $p_i^{n_i} (1 - \frac{1}{p_i})$ , and in  $\phi(a)\phi(b)c$  the term is also  $p_i^{n_i} (1 - \frac{1}{p_i})$ .

(2)  $\min\{m_i, n_i\} = m_i > 0$ : (The same type of argument applies if  $0 < n_i \leq m_i$ .) Here we find the term  $p_i^{m_i+n_i} (1 - \frac{1}{p_i}) p_i^{m_i} (1 - \frac{1}{p_i})$  in  $\phi(ab)\phi(c)$ , while the corresponding term in  $\phi(a)\phi(b)c$  is  $p_i^{m_i} (1 - \frac{1}{p_i}) p_i^{n_i} (1 - \frac{1}{p_i}) p_i^{m_i} = p_i^{m_i+n_i} (1 - \frac{1}{p_i}) p_i^{m_i} (1 - \frac{1}{p_i})$ .

19. a)  $d_4(12!)^4$   
b)  $\binom{4}{1}d_3(12!)^4$   
c)  $d_4(d_{12})^4$

CHAPTER 9  
GENERATING FUNCTIONS

**Section 9.1**

1. The number of integer solutions for the given equations is the coefficient of
  - (a)  $x^{20}$  in  $(1 + x + x^2 + \dots + x^7)^4$ .
  - (b)  $x^{20}$  in  $(1 + x + x^2 + \dots + x^{20})^2(1 + x^2 + x^4 + \dots + x^{20})^2$  or  $(1 + x + x^2 + \dots)^2(1 + x^2 + x^4 + \dots)^2$ .
  - (c)  $x^{30}$  in  $(x^2 + x^3 + x^4)(x^3 + x^4 + \dots + x^8)^4$ .
  - (d)  $x^{30}$  in  $(1 + x + x^2 + \dots + x^{30})^3(1 + x^2 + x^4 + \dots + x^{30})$ .  
 $(x + x^3 + x^5 + \dots + x^{29})$  or  
 $(1 + x + x^2 + \dots)^3(1 + x^2 + x^4 + \dots)(x + x^3 + x^5 + \dots)$ .
  
2.
  - (a)  $(1 + x + x^2 + \dots + x^{35})^5$  or  $(1 + x + x^2 + \dots)^5$
  - (b)  $(x + x^2 + \dots + x^{35})^5$  or  $x^5(1 + x + x^2 + \dots)^5$
  - (c)  $(x^2 + x^3 + \dots + x^{35})^5$  or  $x^{10}(1 + x + x^2 + \dots)^5$
  - (d)  $(1 + x + x^2 + \dots + x^{35})^4(x^{10} + x^{11} + \dots + x^{35})$  or  $(1 + x + x^2 + \dots)^4(x^{10} + x^{11} + x^{12} + \dots)$
  - (e)  $(x^{10} + x^{11} + \dots + x^{25})^2(1 + x + x^2 + \dots + x^{15})^3$  or  $(x^{10} + x^{11} + \dots)^2(1 + x + x^2 + \dots)^3$
  
3.
  - (a) The generating function is either  $(1 + x + x^2 + x^3 + \dots + x^{10})^6$  or  $(1 + x + x^2 + x^3 + \dots)^6$ .  
 [The number of ways to select 10 candy bars is the coefficient of  $x^{10}$  in either case.]
  - (b) The generating function is either  $(1 + x + x^2 + x^3 + \dots + x^r)^n$  or  $(1 + x + x^2 + x^3 + \dots)^n$ .  
 [The number of selections of  $r$  objects is the coefficient of  $x^r$  in either case.]
  
4.
  - (a) The first factor counts the pennies; the nickels are counted by the second factor.
  - (b)  $f(x) = (1 + x + x^2 + \dots)(1 + x^5 + x^{10} + \dots)(1 + x^{10} + x^{20} + \dots)$
  
5.  $c_1 + c_2 + c_3 + c_4 = 20$ ,  $-3 \leq c_1, c_2$ ,  $-5 \leq c_3 \leq 5$ ,  $0 \leq c_4$   
 $(3 + c_1) + (3 + c_2) + (5 + c_3) + c_4 = 31$   
 $x_1 + x_2 + x_3 + x_4 = 31$ ,  $0 \leq x_1, x_2, x_4$ ,  $0 \leq x_3 \leq 10$ .  
 Consequently, the answer is the coefficient of  $x^{31}$  in the generating function  
 $(1 + x + x^2 + \dots)^3(1 + x + x^2 + \dots + x^{10})$ .
  
6.
  - (a)  $(1 + ax)(1 + bx)(1 + cx) \cdots (1 + rx)(1 + sx)(1 + tx)$
  - (b)  $(1 + ax + a^2x^2 + a^3x^3)(1 + bx + b^2x^2 + b^3x^3) \cdots (1 + tx + t^2x^2 + t^3x^3)$ .

## Section 9.2

1. (a)  $(1+x)^6$  (b)  $8(1+x)^7$  (c)  $(1+x)^{-1}$   
 (d)  $6x^3/(1+x)$  (e)  $(1-x^2)^{-1}$  (f)  $x^2/(1-ax)$
2. (a)  $-27, 54, -36, 8, 0, 0, 0, \dots$  (b)  $0, 0, 0, 0, 1, 1, 1, 1, \dots$   
 (c)  $f(x) = x^3/(1-x^2) = x^3[1+x^2+x^4+x^6+\dots] = x^3 + x^5 + x^7 + x^9 + \dots$ , so  $f(x)$  generates the sequence  $0, 0, 0, 1, 0, 1, 0, 1, 0, 1, \dots$   
 (d)  $f(x) = 1/(1+3x) = 1 + (-3x) + (-3x)^2 + (-3x)^3 + \dots$ , so  $f(x)$  generates the sequence  $1, -3, 3^2, -3^3, \dots$   
 (e)  $f(x) = 1/(3-x) = (1/3)[1/(1-(x/3))] = (1/3)[1 + (x/3) + (x/3)^2 + (x/3)^3 + \dots]$ , so  $f(x)$  generates the sequence  $1/3, (1/3)^2, (1/3)^3, (1/3)^4, \dots$   
 (f)  $f(x) = 1/(1-x) + 3x^7 - 11 = (1+x+x^2+x^3+\dots) + 3x^7 - 11$ , so  $f(x)$  generates the sequence  $a_0, a_1, a_2, \dots$ , where  $a_0 = -10$ ,  $a_7 = 4$ , and  $a_i = 1$  for all  $i \neq 0, 7$ .
3. (a)  $g(x) = f(x) - a_3x^3 + 3x^3$   
 (b)  $g(x) = f(x) - a_3x^3 + 3x^3 - a_7x^7 + 7x^7$   
 (c)  $g(x) = 2f(x) - 2a_1x + x - 2a_3x^3 + 3x^3$   
 (d)  $g(x) = 2f(x) + [5/(1-x)] + (1 - 2a_1 - 5)x + (3 - 2a_3 - 5)x^3 + (7 - 2a_7 - 5)x^7$
4.  $\binom{15}{5}(3^5)(2^{10})$
5. (a)  $\binom{-15}{7}(-1)^7 = (-1)^7 \binom{15+7-1}{7}(-1)^7 = \binom{21}{7}$   
 (b)  $\binom{-n}{7}(-1)^7 = (-1)^7 \binom{n+7-1}{7}(-1)^7 = \binom{n+6}{7}$
6.  $\binom{-6}{8}(-1)^8 = (-1)^8 \binom{6+8-1}{8}(-1)^8 = \binom{13}{8}$
7.  $\binom{-5}{10}(-1)^{10} - \binom{5}{1}\binom{-5}{5}(-1)^5 + \binom{5}{2}\binom{-5}{0} = \binom{14}{10} - \binom{5}{1}\binom{9}{5} + \binom{5}{2}$
8. (a)  $\binom{n}{7} + \binom{n}{8} + \binom{n}{5}$  (b)  $\binom{n}{8} + \binom{n}{7} + \binom{n}{6}$   
 (c)  $\binom{n}{r} + \binom{n}{r-1} + \binom{n}{r-2}$
9. (a) 0 (b)  $\binom{-3}{12}(-1)^{12} - 5\binom{-3}{14}(-1)^{14} = \binom{14}{12} - 5\binom{16}{14}$   
 (c)  $\binom{-4}{16}(-1)^{16} + \binom{4}{1}\binom{-4}{14}(-1)^{14} + \binom{4}{2}\binom{-4}{13}(-1)^{13} + \binom{4}{3}\binom{-4}{12}(-1)^{12} + \binom{4}{4}\binom{-4}{11}(-1)^{11} =$   
 $\binom{18}{16} + \binom{4}{1}\binom{17}{14} + \binom{4}{2}\binom{16}{13} + \binom{4}{3}\binom{15}{12} + \binom{14}{11}$
10. (a)  $(x^3 + x^4 + \dots)^4 = x^{12}(1+x+x^2+\dots)^4 = x^{12}(1-x)^{-4}$ . The coefficient of  $x^{12}$  in  $(1-x)^{-4}$  is  $\binom{-4}{12}(-1)^{12} = (-1)^{12} \binom{4+12-1}{12}(-1)^{12} = \binom{15}{12}$ .  
 (b)  $(x^3 + x^4 + \dots + x^9)^4 = x^{12}(1+x+x^2+\dots+x^6)^4$ . The coefficient of  $x^{12}$  in  $[(1-x)^7/(1-x)]^4 = (1-x^7)^4(1-x)^{-4} = [1-4x^7+\dots+x^{28}][\binom{-4}{0}+\dots+\binom{-4}{5}(-x)^5+\dots+\binom{-4}{12}(-x)^{12}+\dots]$

is  $(-4)\binom{-4}{5}(-1)^5 + \binom{-4}{12}(-1)^{12} = (4)(-1)^5\binom{8}{5} + \binom{15}{12} = \binom{15}{12} - 4\binom{8}{5}$ .

11. Consider each package of 25 envelopes as one unit. Then the answer to the problem is the coefficient of  $x^{120}$  in  $(x^6 + x^7 + \dots + x^{39} + x^{40})^4 = x^{24}(1 + x + \dots + x^{34})^4$ . This is the same as the coefficient of  $x^{96}$  in  $[(1 - x^{35})/(1 - x)]^4 = (1 - x^{35})^4(1 - x)^{-4} = [1 - 4x^{35} + 6x^{70} - \dots + x^{140}][\binom{-4}{0} + \dots + \binom{-4}{26}(-x)^{26} + \dots + \binom{-4}{61}(-x)^{61} + \dots + \binom{-4}{96}(-x)^{96} + \dots]$ .

Consequently the answer is  $\binom{-4}{96}(-1)^{96} - 4\binom{-4}{61}(-1)^{61} + 6\binom{-4}{26}(-1)^{26} = \binom{99}{96} - 4\binom{64}{61} + 6\binom{29}{26}$ .

12. (a) The coefficient of  $x^{24}$  in  $(x^2 + x^3 + \dots)^5 = x^{10}(1 + x + x^2 + \dots)^5 = x^{10}(1 - x)^{-5} = x^{10}[\binom{-5}{0} + \binom{-5}{1}(-x) + \binom{-5}{2}(-x)^2 + \dots]$  is  $\binom{-5}{14}(-1)^{14} = (-1)^{14}\binom{5+14-1}{14}(-1)^{14} = \binom{18}{14}$ . This is the number of ways to distribute the 24 bottles of one type of soft drink among the surveyors so that each gets at least two bottles. Since there are two types, the two cases can be distributed according to the given restrictions in  $\binom{18}{14}^2$  ways.

(b) The coefficient of  $x^{24}$  in  $(x^3 + x^4 + \dots)^5$  is  $\binom{13}{9}$  and the answer is  $\binom{16}{14}\binom{13}{9}$ .

13.  $(x + x^2 + x^3 + x^4 + x^5 + x^6)^{12} = x^{12}[(1 - x^6)/(1 - x)]^{12} = x^{12}((1 - x)^6)^{12}[\binom{-12}{0} + \binom{-12}{1}(-x) + \binom{-12}{2}(-x)^2 + \dots]$ . The numerator of the answer is the coefficient of  $x^{18}$  in  $(1 - x^6)^{12}[\binom{12}{0} + \binom{12}{1}(-x) + \dots] = [1 - \binom{12}{1}x^6 + \binom{12}{2}x^{12} - \binom{12}{3}x^{18} + \dots + x^{72}][\binom{-12}{0} + \binom{-12}{1}(-x) + \dots]$  and this equals  $\binom{-12}{18}(-1)^{18} - \binom{12}{1}\binom{-12}{12}(-1)^{12} + \binom{12}{2}\binom{-12}{6}(-1)^6 - \binom{12}{3}\binom{-12}{0} = \binom{29}{18} - \binom{12}{1}\binom{23}{12} + \binom{12}{2}\binom{17}{6} - \binom{12}{3}$ . The final answer is obtained by dividing the last result by  $6^{12}$ , the size of the sample space.

14.  $(x^2 + x^3 + x^4 + x^5)^8(x^5 + x^{10})^2 = x^{26}(1 + x + x^2 + x^3)^8(1 + x^5)^2$ , so we need the coefficient of  $x^{14}$  in  $[(1 - x^4)/(1 - x)]^8(1 + 2x^5 + x^{10}) = (1 - x^4)^8(1 - x)^{-8}(1 + 2x^5 + x^{10}) = [1 + \binom{8}{1}(-x^4) + \binom{8}{2}(-x^4)^2 + \dots + (-x^4)^8][\binom{-8}{0} + \binom{-8}{1}(-x) + \binom{-8}{2}(-x)^2 + \dots](1 + 2x^5 + x^{10})$ .

This coefficient is  $[\binom{-8}{14}(-1)^{14} + 2\binom{-8}{9}(-1)^9 + \binom{-8}{4}(-1)^4] - \binom{8}{1}[\binom{-8}{10}(-1)^{10} + 2\binom{-8}{5}(-1)^5 + \binom{-8}{0}] + \binom{8}{2}[\binom{-8}{6}(-1)^6 + 2\binom{-8}{1}(-1)] - \binom{8}{3}[\binom{-8}{2}(-1)^2] = [(\binom{21}{14}) + 2(\binom{16}{9}) + (\binom{11}{4})] - \binom{8}{1}[(\binom{17}{10}) + 2(\binom{12}{5}) + \binom{7}{0}] + \binom{8}{2}[(\binom{13}{6}) + 2(\binom{8}{1})] - \binom{8}{3}\binom{9}{2}$ . This result is then divided by  $(4^8)(2^2)$ , the size of the sample space, in order to determine the probability.

15. Here we need the coefficient of  $x^n$  in  $(1 + x + x^2 + x^3 + \dots)^2(1 + x^2 + x^4 + \dots) = (1/(1 - x))^2(1/(1 - x^2)) = (1/(1 - x))^3(1/(1 + x))$ .

Using a partial fraction decomposition,  $\frac{1}{1+x} \cdot \frac{1}{(1-x)^3} = \frac{(1/8)}{(1+x)} + \frac{(1/8)}{(1-x)} + \frac{(1/4)}{(1-x)^2} + \frac{(1/2)}{(1-x)^3}$ ,

where the coefficient of  $x^n$  is  $(-1)^n(1/8) + (1/8) + (1/4)\binom{-2}{n}(-1)^n + (1/2)\binom{-3}{n}(-1)^n = (1/8)[1 + (-1)^n] + (1/4)\binom{n+1}{n} + (1/2)\binom{n+2}{n}$ .

16. For the hamburgers we need the coefficient of  $x^{12}$  in  $(x + x^2 + \dots)(x^2 + x^3 + \dots)^3 =$

$x^7/(1-x)^4$ . This is the coefficient of  $x^5$  in  $(1-x)^{-4}$ , i.e.,  $\binom{-4}{5}(-1)^5 = \binom{8}{5}$ .

For the hot dogs we need the coefficient of  $x^{16}$  in  $(x^3+x^4+\dots)(1+x+x^2+\dots+x^5)^3 = x^3(1/(1-x))((1-x^6)/(1-x))^3$ . This is the coefficient of  $x^{13}$  in  $(1-x^6)^3(1-x)^{-4} = [1 - \binom{3}{1}x^6 + \binom{3}{2}x^{12} - x^{18}][\binom{-4}{0} + \binom{-4}{1}(-x) + \dots]$ , i.e.,  $\binom{-4}{13}(-1)^{13} - \binom{3}{1}\binom{-4}{7}(-1)^7 + \binom{3}{2}\binom{-4}{1}(-1) = \binom{16}{13} - \binom{3}{1}\binom{10}{7} + \binom{3}{2}\binom{4}{1}$ .

By the rule of product the total number of distributions for the prescribed conditions is  $\binom{8}{5}[\binom{16}{13} - \binom{3}{1}\binom{10}{7} + \binom{3}{2}\binom{4}{1}]$ .

$$17. (1-x-x^2-x^3-x^4-x^5-x^6)^{-1} = [1-(x+x^2+x^3+x^4+x^5+x^6)]^{-1} \\ = 1 + \underbrace{(x+x^2+\dots+x^6)}_{\text{one roll}} + \underbrace{(x+x^2+\dots+x^6)^2}_{\text{two rolls}} + \underbrace{(x+x^2+\dots+x^6)^3}_{\text{three rolls}} + \dots,$$

where the 1 takes care of the case where the die is not rolled.

$$18. (1-4x)^{-1/2} = [\binom{-1/2}{0} + \binom{-1/2}{1}(-4x) + \binom{-1/2}{2}(-4x)^2 + \dots]. \text{ The coefficient of } x^n \text{ is } \\ \binom{-1/2}{n}(-4)^n =$$

$$\frac{((-1/2)-n+1)((-1/2)-n+2)\cdots((-1/2)-1)(-1/2)}{n!}(-4)^n =$$

$$\frac{(1+2n-2)(1+2n-4)\cdots(1+2)(1)}{n!}(2)^n =$$

$$\frac{(2n-1)(2n-3)\cdots(5)(3)(1)}{n!}(2)^n =$$

$$\frac{[(2n-1)(2n-3)\cdots(5)(3)(1)](2^n)(n!)}{n!n!} = \frac{(2n)!}{n!n!} = \binom{2n}{n}.$$

19. (a) There are  $2^{8-1} = 2^7$  compositions of 8 and  $2^{\lfloor 8/2 \rfloor} = 2^4$  palindromes of 8. Assuming each composition of 8 has the same probability of being generated, the probability a palindrome of 8 is generated is  $2^4/2^7 = 1/8$ .

(b) Assuming each composition of  $n$  has the same probability of being generated, the probability a palindrome of  $n$  is generated is  $2^{\lfloor n/2 \rfloor}/2^{n-1} = 2^{\lfloor n/2 \rfloor - n + 1} = 2^{1 - \lceil n/2 \rceil}$ .

20. (a) If a palindrome of 11 starts with 1, then that palindrome ends in 1. Upon removing '1+' from the start and '+1' from the end of the palindrome, we find a palindrome of 9. And there are  $2^{\lfloor 9/2 \rfloor} = 2^4 = 16$  palindromes of 9.

Similar arguments tells us that there are  $2^{\lfloor 7/2 \rfloor} = 8$  palindromes of 11 that start with 2,  $2^{\lfloor 5/2 \rfloor} = 4$  palindromes of 11 that start with 3, and  $2^{\lfloor 3/2 \rfloor} = 2$  palindromes of 11 that start with 4.

(b) For the palindromes of 12, we find that  $2^{\lfloor 10/2 \rfloor} = 32$  start with 1,  $2^{\lfloor 8/2 \rfloor} = 16$  start with 2,  $2^{\lfloor 6/2 \rfloor} = 8$  start with 3, and  $2^{\lfloor 4/2 \rfloor} = 4$  start with 4.

21. The number of palindromes of  $n$  that start (and end) with  $t$  is the number of palindromes of  $n - 2t$ . This is  $2^{\lfloor (n-2t)/2 \rfloor}$ .

22. Suppose a palindrome of  $n$  has an even number, say  $2k$ , of summands. Let  $s$  be the sum of the last  $k$  summands. Then  $n = 2s$ , contradicting  $n$  odd.

23. Let  $n = 2k$ . The palindromes of  $n$  with an even number of summands have a plus sign at the center and their number is the number of compositions of  $k$  - namely,  $2^{k-1} = 2^{(n/2)-1}$ . Since there are  $2^{n/2}$  palindromes in total, the number with an odd number of summands is  $2^{n/2} - 2^{(n/2)-1} = 2^{n/2}(1 - \frac{1}{2}) = 2^{n/2}(\frac{1}{2}) = 2^{(n/2)-1}$ .

24. (a) The number of palindromes of 10, where all summands are even, equals the number of palindromes of 5, which is  $2^{\lfloor 5/2 \rfloor} = 4$ .

(b)  $2^{\lfloor 6/2 \rfloor} = 8$

(c)  $2^{\lfloor n/4 \rfloor}$

25. (a)  $Pr(Y = y) = (\frac{5}{6})^{y-1}(\frac{1}{6})$ ,  $y = 1, 2, 3, \dots$

(b) and (c) Using the general formulas at the end of Example 9.18, with  $p = \frac{1}{6}$  and  $q = 1 - p = \frac{5}{6}$ , it follows that

$E(Y) = \frac{1}{p} = \frac{1}{(1/6)} = 6$ , and

$\sigma_Y = \sqrt{\text{Var}(Y)} = \sqrt{q/p^2} = \sqrt{(\frac{5}{6})/(1/6)^2} = \sqrt{(\frac{5}{6})(36)} = \sqrt{30} \doteq 5.477226$ .

26. Here we want  $\sum_{i=1}^{\infty} Pr(Y = 2i)$ .

$\sum_{i=1}^{\infty} Pr(Y = 2i) = \sum_{i=1}^{\infty} (\frac{5}{6})^{2i-1}(\frac{1}{6}) = (\frac{1}{6}) \sum_{i=1}^{\infty} (\frac{5}{6})^{2i-1} = (\frac{1}{6})[(\frac{5}{6}) + (\frac{5}{6})^3 + (\frac{5}{6})^5 + \dots] = (\frac{1}{6})(\frac{5}{6})[1 + (\frac{5}{6})^2 + (\frac{5}{6})^4 + \dots] = (\frac{5}{36})\frac{1}{1-(\frac{5}{6})^2} = (\frac{5}{36})\frac{1}{1-(\frac{25}{36})} = (\frac{5}{36})(\frac{36}{11}) = \frac{5}{11}$ .

27. Let the discrete random variable  $Y$  count the number of tosses Leroy makes until he gets the first tail. Then  $Pr(Y = y) = (\frac{2}{3})^{y-1}(\frac{1}{3})$ ,  $y = 1, 2, 3, \dots$

Here we are interested in  $Pr(Y = 1) + Pr(Y = 3) + Pr(Y = 5) + \dots = (\frac{1}{3}) + (\frac{2}{3})^2(\frac{1}{3}) + (\frac{2}{3})^4(\frac{1}{3}) + \dots = (\frac{1}{3})[1 + (\frac{2}{3})^2 + (\frac{2}{3})^4 + \dots] = (\frac{1}{3})\frac{1}{1-(\frac{2}{3})^2} = (\frac{1}{3})\frac{1}{5/9} = (\frac{1}{3})(\frac{9}{5}) = \frac{3}{5}$ .

28. Since  $E(Y) = \frac{7}{3} = \frac{1}{p}$ , the probability of success for each Bernoulli trial is  $p = \frac{3}{7}$ .

(a)  $Pr(Y = 3) = \frac{4^2}{7}(\frac{3}{7}) = \frac{48}{343} \doteq 0.139942$ .

(b)  $Pr(Y = 1) = (\frac{3}{7})$  and  $Pr(Y = 2) = (\frac{4}{7})(\frac{3}{7}) = \frac{12}{49}$ , so  $Pr(Y \geq 3) = 1 - (\frac{3}{7}) - (\frac{12}{49}) = \frac{49-21-12}{49} = \frac{16}{49} \doteq 0.326531$ .

Alternately,  $Pr(Y \geq 3) = (\frac{4}{7})^2(\frac{3}{7}) + (\frac{4}{7})^3(\frac{3}{7}) + (\frac{4}{7})^4(\frac{3}{7}) + \dots = (\frac{4}{7})^2(\frac{3}{7})[1 + (\frac{4}{7}) + (\frac{4}{7})^2 + \dots] = (\frac{4}{7})^2(\frac{3}{7})\frac{1}{1-(\frac{4}{7})} = (\frac{4}{7})^2(\frac{3}{7})\frac{1}{(31/7)} = (\frac{4}{7})^2 = \frac{16}{49}$

(c)  $Pr(Y \geq 5) = \sum_{y=5}^{\infty} (\frac{4}{7})^{y-1}(\frac{3}{7}) = [(\frac{4}{7})^4(\frac{3}{7}) + (\frac{4}{7})^5(\frac{3}{7}) + (\frac{4}{7})^6(\frac{3}{7}) + \dots] = (\frac{4}{7})^4(\frac{3}{7})[1 + (\frac{4}{7}) + (\frac{4}{7})^2 + \dots] = (\frac{4}{7})^4(\frac{3}{7})\frac{1}{1-(\frac{4}{7})} = (\frac{4}{7})^4 = \frac{256}{2401} \doteq 0.106622$ .

$$(d) \Pr(Y \geq 5|Y \geq 3) = \frac{\Pr(Y \geq 5 \text{ and } Y \geq 3)}{\Pr(Y \geq 3)} = \Pr(Y \geq 5)/\Pr(Y \geq 3) = \left(\frac{4}{7}\right)^4 / \left(\frac{4}{7}\right)^2 = \left(\frac{4}{7}\right)^2.$$

$$(e) \Pr(Y \geq 6|Y \geq 4) = \left(\frac{4}{7}\right)^5 / \left(\frac{4}{7}\right)^3 = \left(\frac{4}{7}\right)^2.$$

$$(f) \text{Var}(Y) = q/p^2, \text{ where } q = 1 - p = \frac{4}{7}. \text{ So } \text{Var}(Y) = \left(\frac{4}{7}\right) / \left(\frac{3}{7}\right)^2 = \left(\frac{4}{7}\right) / \left(\frac{9}{49}\right) = \left(\frac{4}{7}\right) \left(\frac{49}{9}\right) = \frac{28}{9}. \text{ Consequently, } \sigma_Y = \sqrt{28/9} \doteq 1.763834.$$

29. (a) The differences are  $3 - 1, 6 - 3, 8 - 6, 15 - 8,$  and  $15 - 15$  - that is 2, 3, 2, 7, and 0, where  $2 + 3 + 2 + 7 + 0 = 14$ .

$$(b) \{3, 5, 8, 15\}$$

$$(c) \{1 + a, 1 + a + b, 1 + a + b + c, 1 + a + b + c + d\}$$

30. Using the ideas developed in Example 9.17, we consider one such subset:  $1 \leq 1 < 3 < 6 < 10 < 15 < 30 < 42 \leq 50$ . This subset determines the differences 0, 2, 3, 4, 5, 15, 12, 8, which sum to 49.

A second such subset is  $1 \leq 7 < 9 < 15 < 21 < 32 < 43 < 50 \leq 50$ , which provides the differences 6, 2, 6, 6, 11, 11, 7, 0, which also sum to 49.

These observations suggest a one-to-one correspondence between the subsets and the integer solutions of  $c_1 + c_2 + c_3 + \dots + c_8 = 49$  where  $c_1, c_8 \geq 0$  and  $c_i \geq 2$  for  $2 \leq i \leq 7$ . The number of these solutions is the coefficient of  $x^{49}$  in the generating function  $(1 + x + x^2 + \dots)(x^2 + x^3 + \dots)^6(1 + x + x^2 \dots) = [1/(1-x)^2][x^{12}/(1-x)^6] = x^{12}/(1-x)^8$ .

The answer then is the coefficient of  $x^{37}$  in  $(1-x)^{-8}$  and this is  $\binom{-8}{37}(-1)^{37} = (-1)^{37} \binom{8+37-1}{37}(-1)^{37} = \binom{44}{37}$ .

$$31. c_k = \sum_{i=0}^k i(k-i)^2 = \sum_{i=0}^k i(k^2 - 2ki + i^2) = k^2 \sum_{i=0}^k i - 2k \sum_{i=0}^k i^2 + \sum_{i=0}^k i^3 = k^2[k(k+1)/2] - 2k[k(k+1)(2k+1)/6] + [(k^2)(k+1)^2/4] = (k^4 + k^3)/2 - (k^2)(k+1)(2k+1)/3 + (k^2)(k+1)^2/4 = (1/12)[6k^4 + 6k^3 - 4k^2(2k^2 + 3k + 1) + 3k^2(k^2 + 2k + 1)] = (1/12)[k^4 - k^2] = (1/12)(k^2)(k^2 - 1).$$

$$32. (a) (i) c_0 = a_1 b_0 = 1; c_1 = a_0 b_1 + a_1 b_0 = 2; c_2 = a_0 b_2 + a_1 b_1 + a_2 b_0 = 3; c_3 = a_0 b_3 + a_1 b_2 + a_2 b_1 + a_3 b_0 = 4.$$

$$(ii) c_0 = 1; c_1 = 3; c_2 = 7; c_3 = 15$$

$$(iii) c_0 = 1; c_1 = 2; c_2 = 3; c_3 = 4$$

$$(b) (i) c_n = n + 1$$

$$(ii) c_n = 1 + 2 + 2^2 + \dots + 2^n = 2^{n+1} - 1$$

$$(iii) c_0 = 1; c_1 = 2; c_2 = 3; c_n = 4, n \geq 3.$$

$$33. (a) (1 + x + x^2 + x^3 + x^4)(0 + x + 2x^2 + 3x^3 + \dots) = \sum_{i=0}^{\infty} c_i x^i \text{ where } c_0 = 0, c_1 = 1,$$

$c_2 = 1 + 2 = 3$ ,  $c_3 = 1 + 2 + 3 = 6$ ,  $c_4 = 1 + 2 + 3 + 4 = 10$ , and  
 $c_n = n + (n - 1) + (n - 2) + (n - 3) + (n - 4) = 5n - 10$  for all  $n \geq 5$ .

(b)  $(1 - x + x^2 - x^3 + \dots)(1 - x + x^2 - x^3 + \dots) = \frac{1}{(1+x)^2} = (1+x)^{-2}$ , the generating function for the sequence  $\binom{-2}{0}$ ,  $\binom{-2}{1}$ ,  $\binom{-2}{2}$ ,  $\binom{-2}{3}$ ,  $\dots$ . Hence the convolution of the given pair of sequences is  $c_0, c_1, c_2, \dots$ , where  
 $c_n = \binom{-2}{n} = (-1)^n \binom{2+n-1}{n} = (-1)^n \binom{n+1}{n} = (-1)^n (n+1)$ ,  $n \in \mathbf{N}$ .  
 [This is the alternating sequence  $1, -2, 3, -4, 5, -6, 7, \dots$ ]

### Section 9.3

1.  $7; 6+1; 5+2; 5+1+1; 4+3; 4+2+1; 4+1+1+1; 3+3+1; 3+2+2; 3+2+1+1; 3+1+1+1+1; 2+2+2+1; 2+2+1+1+1; 2+1+1+1+1+1; 1+1+1+1+1+1+1$

2. (a)  $f(x) = [1/(1-x^2)][1/(1-x^4)][1/(1-x^6)] \dots = \prod_{i=1}^{\infty} [1/(1-x^{2i})]$

(b)  $g(x) = (1+x^2)(1+x^4)(1+x^6) \dots = \prod_{i=1}^{\infty} (1+x^{2i})$

(c)  $h(x) = (1+x)(1+x^3)(1+x^5) \dots = \prod_{i=1}^{\infty} (1+x^{2i-1})$

3. The number of partitions of 6 into 1's, 2's, and 3's is 7.

4. (a)  $[1/(1-t^2)][1/(1-t^3)][1/(1-t^5)][1/(1-t^7)]$

(b)  $[1/(1-t^2)][t^{12}/(1-t^3)][t^{20}/(1-t^5)][t^{35}/(1-t^7)]$

5. (a) and (b)  $(1+x^2+x^4+x^6+\dots)(1+x^4+x^8+\dots)(1+x^6+x^{12}+\dots) \dots$   
 $= \prod_{i=1}^{\infty} \frac{1}{1-x^{2i}}$

6. (a)  $f(x) = (1+x+x^2+\dots+x^5)(1+x^2+x^4+\dots+x^{10}) \dots =$   
 $\prod_{i=1}^{\infty} (1+x^i+x^{2i}+\dots+x^{5i}) = \prod_{i=1}^{\infty} [(1-x^{6i})/(1-x^i)]$

(b)  $\prod_{i=1}^{12} (1+x^i+x^{2i}+\dots+x^{5i}) = \prod_{i=1}^{12} [(1-x^{6i})/(1-x^i)]$

7. Let  $f(x)$  be the generating function for the number of partitions of  $n$  where no summand appears more than twice. Let  $g(x)$  be the generating function for the number of partitions of  $n$  where no summand is divisible by 3.

$$g(x) = \frac{1}{1-x} \cdot \frac{1}{1-x^2} \cdot \frac{1}{1-x^3} \cdot \frac{1}{1-x^5} \cdot \frac{1}{1-x^7} \dots$$

$$f(x) = (1+x+x^2)(1+x^2+x^4)(1+x^3+x^6)(1+x^4+x^8) \dots$$

$$= \frac{1-x^3}{1-x} \cdot \frac{1-x^6}{1-x^2} \cdot \frac{1-x^9}{1-x^3} \cdot \frac{1-x^{12}}{1-x^4} \dots = g(x).$$

8. Let  $f(x)$  be the generating function for the number of partitions of  $n$  where no summand is divisible by 4;  $g(x)$  is the generating function for the number of partitions of  $n$  where no even summand is repeated (odd summands may be repeated).

$$f(x) = \frac{1}{1-x} \cdot \frac{1}{1-x^2} \cdot \frac{1}{1-x^3} \cdot \frac{1}{1-x^5} \cdot \frac{1}{1-x^7} \cdot \frac{1}{1-x^9} \dots$$

$$\begin{aligned}
g(x) &= \frac{1}{1-x} \cdot (1+x^2) \cdot \frac{1}{1-x^3} \cdot (1+x^4) \cdot \frac{1}{1-x^5} \cdot (1+x^6) \cdots \\
&= \frac{1}{1-x} \cdot \frac{1-x^4}{1-x^2} \cdot \frac{1}{1-x^3} \cdot \frac{1-x^8}{1-x^4} \cdot \frac{1}{1-x^5} \cdot \frac{1-x^{12}}{1-x^6} \cdot \frac{1}{1-x^7} \cdot \frac{1-x^{16}}{1-x^8} \cdots \\
&= \frac{1}{1-x} \cdot \frac{1}{1-x^2} \cdot \frac{1}{1-x^3} \cdot \frac{1}{1-x^5} \cdot \frac{1}{1-x^6} \cdot \frac{1}{1-x^7} \cdot \frac{1}{1-x^9} \cdots = f(x)
\end{aligned}$$

9. This result follows from the one-to-one correspondence between the Ferrers graphs with summands (rows) not exceeding  $m$  and the transpose graphs (also Ferrers graphs) that have  $m$  summands (rows).
10. Consider the Ferrers graph for a partition of  $2n$  into  $n$  summands (rows). Remove the first column of dots and the result is a Ferrers graph for a partition of  $n$ . This correspondence is one-to-one, from which the result follows.

### Section 9.4

1. (a)  $e^{-x}$       (b)  $e^{2x}$       (c)  $e^{-ax}$   
 (d)  $e^{a^2x}$       (e)  $ae^{a^2x}$       (f)  $xe^{2x}$
2. (a)  $f(x) = 3e^{3x} = 3 \sum_{i=0}^{\infty} \frac{(3x)^i}{i!}$ , so  $f(x)$  is the exponential generating function for the sequence  $3, 3^2, 3^3, \dots$   
 (b)  $f(x) = 6e^{5x} - 3e^{2x} = 6 \sum_{i=0}^{\infty} \frac{(5x)^i}{i!} - 3 \sum_{i=0}^{\infty} \frac{(2x)^i}{i!}$ , so  $f(x)$  is the exponential generating function for the sequence  $3, 24, 138, \dots, 6(5^n) - 3(2^n), \dots$   
 (c)  $1, 1, 3, 1, 1, 1, \dots$   
 (d)  $1, 9, 14, -10, 2^4, 2^5, 2^6, \dots$   
 (e)  $f(x) = 1 + x + x^2 + x^3 + \dots = \sum_{i=0}^{\infty} i! \left(\frac{x}{i!}\right)$ , so  $f(x)$  is the exponential generating function for the sequence  $0!, 1!, 2!, 3!, \dots$   
 (f)  $f(x) = 3[1 + 2x + (2x)^2 + (2x)^3 + \dots] + \sum_{i=0}^{\infty} \frac{x^i}{i!}$ , so  $f(x)$  is the exponential generating function for the sequence  $4, 7, 25, 145, \dots, (3n!)2^n + 1, \dots$
3. (a)  $g(x) = f(x) + [3 - a_3](x^3/3!)$   
 (b)  $g(x) = f(x) + [-1 - a_3](x^3/3!) = e^{5x} - (126x^3)/3!$   
 (c)  $g(x) = 2f(x) + [2 - 2a_1](x^1/1!) + [4 - 2a_2](x^2/2!)$   
 (d)  $g(x) = 2f(x) + 3e^x + [2 - 2a_1 - 3](x^1/1!) + [4 - 2a_2 - 3](x^2/2!) + [8 - 2a_3 - 3](x^3/3!)$
4. (a)  $(x + (x^2/2!) + (x^3/3!) + \dots)^4 = (e^x - 1)^4 = e^{4x} - \binom{4}{1}e^{3x} + \binom{4}{2}e^{2x} - \binom{4}{3}e^x + \binom{4}{4}$ . The coefficient of  $x^{12}/12!$  in  $(e^x - 1)^4$  is  $4^{12} - \binom{4}{1}3^{12} + \binom{4}{2}2^{12} - \binom{4}{3}1^{12}$ .  
 (b) How many onto functions are there from  $A = \{1, 2, 3, \dots, 12\}$  to  $B = \{\text{red, white, blue, black}\}$ ?  
 (c)  $f(x) = (1 + x + (x^2/2!) + \dots)^2(1 + (x^2/2!) + (x^4/4!) + \dots)^2 = e^{2x}[(e^x + e^{-x})/2]^2 =$

$$(1/4)(e^{2x})(e^{2x} + 2 + e^{-2x}) = (1/4)(e^{4x} + 2e^{2x} + 1).$$

Here the coefficient of  $x^{12}/(12!)$  is  $(1/4)[4^{12} + 2(2^{12})]$  and this counts the number of signals where the number of blue flags is even and the number of black flags is even.

$g(x) = (1 + x + (x^2/2!) + \dots)^2(x + (x^3/3!) + \dots)^2 = e^{2x}[(e^x - e^{-x})/2]^2 = (1/4)(e^{4x} - 2e^{2x} + 1)$ . The coefficient of  $x^{12}/(12!)$  in  $g(x)$  is  $(1/4)[4^{12} - 2(2^{12})]$ , and this counts the signals where the numbers of blue and black flags are both odd.

Consequently, the number of signals where the total number of blue and black flags is even is  $(1/4)[4^{12} + 2(2^{12})] + (1/4)[4^{12} - 2(2^{12})] = (1/2)(4^{12})$ .

5. We find that

$$\begin{aligned} \frac{1}{1-x} &= 1 + x + x^2 + x^3 + \dots \\ &= (0!) \frac{x^0}{0!} + (1!) \frac{x^1}{1!} + (2!) \frac{x^2}{2!} + (3!) \frac{x^3}{3!} + \dots, \end{aligned}$$

so  $1/(1-x)$  is the exponential generating function for the sequence  $0!, 1!, 2!, 3!, \dots$

6. (a) (i)  $(1+x)^2(1+x+(x^2/2!))^2$

(ii)  $(1+x)(1+x+(x^2/2!))(1+x+(x^2/2!)+(x^3/3!)+(x^4/4!))^2$

(iii)  $(1+x)^3(1+x+(x^2/2!))^4$

(b)  $(1+x) \cdot (1+x+(x^2/2!)) \cdot (1+x+(x^2/2!)+(x^3/3!)+(x^4/4!)) \cdot ((x^2/2!)+(x^3/3!)+(x^4/4!))$ .

7. The answer is the coefficient of  $\frac{x^{25}}{25!}$  in  $(\frac{x^3}{3!} + \frac{x^4}{4!} + \dots + \frac{x^{10}}{10!})^4$ .

8.  $h(x) = f(x)g(x) = c_0 + c_1x + c_2(x^2/2!) + c_3(x^3/3!) + \dots$ , where

$$c_n(x^n/n!) = \sum_{i=0}^n (a_i x^i/i!)(b_{n-i} x^{n-i}/(n-i)!) =$$

$$[\sum_{i=0}^n (a_i b_{n-i})/(i!(n-i)!)] x^n =$$

$$[\sum_{i=0}^n n!/(i!(n-i)!)] a_i b_{n-i} (x^n/n!) = [\sum_{i=0}^n \binom{n}{i} a_i b_{n-i}] (x^n/n!)$$

9. (a)  $(1/2)[3^{20} + 1]/(3^{20})$

(b)  $(1/4)[3^{20} + 3]/(3^{20})$

(c)  $(1/2)[3^{20} - 1]/(3^{20})$

(d)  $(1/2)[3^{20} - 1]/(3^{20})$

(e)  $(1/2)[3^{20} + 1]/(3^{20})$

10. (a)  $f(x) = (x + (x^3/3!) + (x^5/5!) + \dots) \cdot (x + (x^2/2!) + (x^3/3!) + \dots) \cdot (e^x)(e^x) =$

$$(1/2)(e^x - 1)^2(e^{2x}) = (1/2)(e^x - 1)(e^{3x} - e^x) = (1/2)(e^{4x} - e^{3x} - e^{2x} + e^x).$$

The answer is the coefficient of  $x^{20}/(20!)$  in  $f(x)$  which is  $(1/2)[4^{20} - 3^{20} - 2^{20} + 1]$ .

(b)  $g(x) = (1 + x + (x^3/3!) + (x^4/4!) + \dots)^4 = (e^x - (x^2/2))^4 = e^{4x} - \binom{4}{1} e^{3x}(x^2/2) + \binom{4}{2} e^{2x}(x^2/2)^2 - \binom{4}{3} e^x(x^2/2)^3 + (x^2/2)^4$ . The coefficient of  $x^{20}/(20!)$  in  $g(x)$  is  $4^{20} - \binom{4}{1}(1/2)(3^{18})(20)(19) + \binom{4}{2}(1/4)(2^{16})(20)(19)(18)(17) - \binom{4}{3}(1/8)(1^{14})(20)(19)(18)(17)(16)(15)$

(c)  $h(x) = (1 + x + (x^3/3!) + (x^4/4!) + \dots)^4 = (e^x - (x^2/2))^4 = e^{4x} - \binom{4}{1} e^{3x}(x^3/6) +$

$\binom{4}{2}e^{2x}(x^3/6)^2 - \binom{4}{3}e^x(x^3/6)^3 + (x^3/6)^4$ . The coefficient of  $x^{20}/(20!)$  in  $h(x)$  is  $4^{20} - \binom{4}{1}(1/6)(3^{17})(20)(19)(18) + \binom{4}{2}(1/6)^2(2^{14})(20)(19)(18)(17)(16)(15) - \binom{4}{3}(1/6)^3[(20!)/(11!)]$ .

(d) The coefficient of  $x^{20}/(20!)$  in  $(e^x)^3(1 + (x^2/2!)) = e^{3x} + e^{3x}(x^2/2!)$  is  $3^{20} + (1/2)(3^{18})(20)(19)$ .

## Section 9.5

- (a)  $1 + x + x^2$  is the generating function for the sequence 1, 1, 1, 0, 0, ..., so  $(1 + x + x^2)/(1 - x)$  is the generating function for the sequence 1, 1 + 1, 1 + 1 + 1, 1 + 1 + 1 + 0, ... - that is, the sequence 1, 2, 3, 3, ...

(b)  $1 + x + x^2 + x^3$  is the generating function for the sequence 1, 1, 1, 1, 0, 0, ..., so  $(1 + x + x^2 + x^3)/(1 - x)$  is the generating function for the sequence 1, 1 + 1, 1 + 1 + 1, 1 + 1 + 1 + 1, 1 + 1 + 1 + 1 + 0, 1 + 1 + 1 + 1 + 0 + 0, ... - that is, the sequence 1, 2, 3, 4, 4, 4, ...

(c)  $1 + 2x$  is the generating function for the sequence 1, 2, 0, 0, 0, ..., so  $(1 + 2x)/(1 - x)$  is the generating function for the sequence 1, 1 + 2, 1 + 2 + 0, 1 + 2 + 0 + 0, ... - that is, the sequence 1, 3, 3, 3, ... Consequently,  $(1/(1 - x))[(1 + 2x)/(1 - x)] = (1 + 2x)/(1 - x)^2$  is the generating function for the sequence 1, 1 + 3, 1 + 3 + 3, 1 + 3 + 3 + 3, ... - that is, the sequence 1, 4, 7, 10, ...
- (a) (i)  $x$                       (ii)  $x/(1 - x)$                       (iii)  $x/(1 - x)^2$                       (iv)  $x/(1 - x)^3$

$\sum_{k=1}^n k =$  the coefficient of  $x^n$  in  $x/(1 - x)^3$   
 $=$  the coefficient of  $x^n$  in  $x(1 - x)^{-3}$   
 (b)  $=$  the coefficient of  $x^{n-1}$  in  $(1 - x)^{-3}$   
 $= \binom{-3}{n-1}(-1)^{n-1} = (-1)^{n-1} \binom{3+(n-1)-1}{(n-1)}(-1)^{n-1}$   
 $= \binom{n+1}{n-1} = \frac{1}{2}(n+1)(n)$
- $f(x) = [x(1+x)]/(1-x)^3$  generates  $0^2, 1^2, 2^2, 3^2, \dots$ ;  $[x(1+x)]/(1-x)^3 = 0^2 + 1^2x + 2^2 \cdot x^2 + 3^2 \cdot x^3 + \dots$ ;  $(d/dx)[(x+x^2)/(1-x)^3] = 1^3 + 2^3 \cdot x + 3^3 \cdot x^2 + \dots$ ;  $x(d/dx)[(x+x^2)/(1-x)^3] = 0^3 + 1^3x + 2^3 \cdot x^2 + 3^3 \cdot x^3 + \dots$ ;  $(d/dx)[(x+x^2)/(1-x)^3] = (x^2 + 4x + 1)/(1-x)^4$ , so  $x(x^2 + 4x + 1)/(1-x)^5$  generates  $0^3, 0^3 + 1^3, 0^3 + 1^3 + 2^3, \dots$ , and the coefficient of  $x^n$  is  $\sum_{i=0}^n i^3$ .

$(x^3 + 4x^2 + x)(1-x)^{-5} = (x^3 + 4x^2 + x)[\binom{-5}{0} + \binom{-5}{1}(-x) + \binom{-5}{2}(-x)^2 + \dots]$ . Here the coefficient of  $x^n$  is  $\binom{-5}{n-3}(-1)^{n-3} + 4\binom{-5}{n-2}(-1)^{n-2} + \binom{-5}{n-1}(-1)^{n-1} = \binom{n+1}{n-3} + 4\binom{n+2}{n-2} + \binom{n+3}{n-1} = (1/4!)[(n+1)(n)(n-1)(n-2) + 4(n+2)(n+1)(n)(n-1) + (n+3)(n+2)(n+1)(n)] = [(n+1)(n)/4!](6n^2 + 6n) = (1/4)(n+1)(n)(n^2 + n) = [(n+1)(n)/2]^2$ .
- The function  $(1+x)f(x)$  generates the sequence  $a_0, a_0 + a_1, a_1 + a_2, a_2 + a_3, \dots$ . For the sequence  $a_0, a_0 + a_1, a_0 + a_1 + a_2, a_1 + a_2 + a_3, a_2 + a_3 + a_4, \dots$ , the generating function is

$$(1 + x + x^2)f(x).$$

5.  $(1-x)f(x) = (1-x)(a_0 + a_1x + a_2x^2 + a_3x^3 + \dots) = a_0 + (a_1 - a_0)x + (a_2 - a_1)x^2 + (a_3 - a_2)x^3 + \dots$ , so  $(1-x)f(x)$  is the generating function for the sequence  $a_0, a_1 - a_0, a_2 - a_1, a_3 - a_2, \dots$ .
6.  $[f(x) - f(1)]/(x-1) = (1/(x-1))[(a_0 - a_0) + (a_1x - a_1) + (a_2x^2 - a_2) + \dots]$ . For  $n \geq 0$ ,  $(a_nx^n - a_n)/(x-1) = a_n(x^n - 1)/(x-1) = a_n(x^{n-1} + x^{n-2} + \dots + x^2 + x + 1)$ , so  $[f(x) - f(1)]/(x-1) = a_1 + a_2(x+1) + a_3(x^2+x+1) + a_4(x^3+x^2+x+1) + \dots$ . Hence the coefficient of  $x^n$ , for  $n \geq 0$ , is  $\sum_{i=n+1}^{\infty} a_i$ .
7. Since  $e^x$  is the generating function for  $1, 1, 1/2!, 1/3!, \dots$ , it follows that  $e^x/(1-x)$  generates the sequence  $a_0, a_1, a_2, \dots$ , where  $a_n = \sum_{i=0}^n (1/i!)$ .
8. (a)  $\frac{1}{1-x} = 1 + x + x^2 + x^3 + \dots$  is the generating function for the sequence  $1, 1, 1, 1, \dots$ . Applying the summation operator, we then learn that  $(\frac{1}{1-x})^2$  is the generating function for the sequence  $1, 1+1, 1+1+1, 1+1+1+1, \dots$  - that is, the sequence  $1, 2, 3, 4, \dots$ . Consequently,  $x/(1-x)^2$  is the generating function for  $0, 1, 2, 3, 4, \dots$  and  $x/(1-x)^3$  the generating function for  $0, 0+1, 0+1+2, 0+1+2+3, 0+1+2+3+4, \dots$  - that is, the sequence  $0, 1, 3, 6, 10, \dots$  (where  $1, 3, 6, 10, \dots$  are the triangular numbers).  
 (b) The sum of the first  $n$  triangular numbers is the coefficient of  $x^n$  in the generating function  $x/(1-x)^4 = x(1-x)^{-4} = x[\binom{-4}{0} + \binom{-4}{1}(-x) + \binom{-4}{2}(-x)^2 + \dots]$ . So the answer is the coefficient of  $x^{n-1}$  in  $(1-x)^{-4}$  and this is  $\binom{-4}{n-1}(-1)^{n-1} = (-1)^{n-1} \binom{4+(n-1)-1}{n-1} (-1)^{n-1} = \binom{n+2}{n-1} = (1/6)n(n+1)(n+2)$ , as we learned in Example 4.5.

### Supplementary Exercises

1. (a)  $6/(1-x) + 1/(1-x)^2$  (b)  $1/(1-ax)$   
 (c)  $1/[1-(1+a)x]$  (d)  $1/(1-x) + 1/(1-ax)$
2. Let  $f(x) = (x^5 + x^6 + x^{11} + x^{14} + x^{17})^{10} = x^{50}(1 + x^3 + x^6 + x^9 + x^{12})^{10}$ . The coefficient of  $x^{83}$  in  $f(x)$  equals the coefficient of  $x^{33}$  in  $((1-x^{15})/(1-x^3))^{10} = (1-x^{15})^{10}(1-x^3)^{-10} = [1 - \binom{10}{1}x^{15} + \binom{10}{2}x^{30} - \dots + x^{150}] \cdot [\binom{-10}{0} + \binom{-10}{1}(-x^3) + \binom{-10}{2}(-x^3)^2 + \dots]$ . This coefficient is  $\binom{-10}{11}(-1)^{11} - \binom{10}{1} \binom{-10}{6}(-1)^6 + \binom{10}{2} \binom{-10}{1}(-1)^1 = \binom{20}{11} - \binom{10}{1} \binom{15}{6} + \binom{10}{2} \binom{10}{1}$ .
3. The generating function for each type of bullet is  $(x^2 + x^3 + \dots + x^7)^4 = x^8(1 + x + x^2 + \dots + x^5)^4$ . The coefficient of  $x^{12}$  in  $(1-x^6)^4(1-x)^{-4} = [1 - \binom{4}{1}x^6 + \binom{4}{2}x^{12} - \dots][\binom{-4}{0} + \binom{-4}{1}(-x) + \binom{-4}{2}(-x)^2 + \dots]$  is  $\binom{-4}{12}(-1)^{12} - \binom{4}{1} \binom{-4}{6}(-1)^6 + \binom{4}{2} \binom{-4}{0} = \binom{15}{12} - \binom{4}{1} \binom{9}{6} + \binom{4}{2}$ . By the rule of product the answer is  $[\binom{15}{12} - \binom{4}{1} \binom{9}{6} + \binom{4}{2}]^2$ .
4.  $f(x) = (1 + x + x^3 + x^5 + \dots)(1 + x^2 + x^6 + x^{10} + \dots) \dots = \prod_{i=1}^{\infty} (1 + x^i + x^{3i} + x^{5i} + \dots)$

5. Let  $f(x)$  be the generating function for the number of partitions of  $n$  where no even summand is repeated (although an odd summand may be repeated);  $g(x)$  is the generating function for the number of partitions of  $n$  in which no summand occurs more than three times. Then  $g(x) = (1+x+x^2+x^3)(1+x^2+x^4+x^6)(1+x^3+x^6+x^9)\dots = [(1+x)(1+x^2)][(1+x^2)(1+x^4)][(1+x^3)(1+x^6)]\dots = [(1-x^2)/(1-x)](1+x^2)[(1-x^4)/(1-x^2)](1+x^4)[(1-x^6)/(1-x^3)](1+x^6)\dots = [1/(1-x)](1+x^2)[1/(1-x^3)](1+x^4)[1/(1-x^5)](1+x^6)\dots = (1+x+x^2+x^3+\dots)(1+x^2)(1+x^3+x^6+x^9+\dots)(1+x^4)(1+x^5+x^{10}+x^{15}+\dots)(1+x^6)\dots = f(x).$

6. This result is the coefficient of  $x^{10}/(10!)$  in  $(1+(x^2/2!)+(x^3/3!)+\dots)^4 = (e^x - x)^4 = e^{4x} - \binom{4}{1}xe^{3x} + \binom{4}{2}x^2e^{2x} - \binom{4}{3}x^3e^x + \binom{4}{4}x^4$ . This coefficient is  $4^{10} - \binom{4}{1}(10)(3^9) + \binom{4}{2}(10)(9)(2^8) -$

$$\binom{4}{3}(10)(9)(8).$$

7. (a)  $(1-2x)^{-5/2} = 1 + \sum_{r=1}^{\infty} \frac{(-5/2)((-5/2)-1)((-5/2)-2)\dots((-5/2)-r+1)}{r!}(-2x)^r$   
 $= 1 + \sum_{r=1}^{\infty} \frac{5(7)(9)\dots(3+2r)}{r!}x^r$ , so  $g(x)$  is the exponential generating function for 1, 5, 5(7), 5(7)(9), ...

$$(b) (1-ax)^b = 1 + \sum_{r=1}^{\infty} \frac{b(b-1)(b-2)\dots(b-r+1)}{r!}(-ax)^r = 1 - abx + b(b-1)a^2x^2/2! + \dots$$

Consequently, by comparing coefficients of like powers of  $x$ , we have  $-ab = 7, b(b-1)a^2 = 7 \cdot 11$  and  $a = 4, b = -7/4$ .

8. For each partition of  $n$ , place a row of  $n+k$  dots above the top row in its Ferrers graph and the result is a Ferrers graph for a partition of  $2n+k$  where  $n+k$  is the largest summand. This one-to-one correspondence yields  $P_1 = P_2$ . Taking the transpose of a Ferrers graph for a partition in  $P_2$  yields the Ferrers graph for a partition in  $P_3$ , and vice versa. The result now follows from these two observations.

9. For each  $n \in \mathbb{Z}^+$ ,  $(1+x)^n = \binom{n}{0} + \binom{n}{1}x + \binom{n}{2}x^2 + \binom{n}{3}x^3 + \dots + \binom{n}{n}x^n$ . Taking the derivative of both sides we find that

$$n(1+x)^{n-1} = \binom{n}{1} + 2\binom{n}{2}x + 3\binom{n}{3}x^2 + \dots + n\binom{n}{n}x^{n-1}.$$

When  $x = 1$  we obtain

$$n(1+1)^{n-1} = n(2^{n-1}) = \binom{n}{1} + 2\binom{n}{2} + 3\binom{n}{3} + \dots + n\binom{n}{n}.$$

10.  $f(x) = (1+x)(1+x^2+x^4)(1+x^3+x^6+x^9)\dots(1+x^k+x^{2k}+x^{3k}+\dots+x^{k^2})\dots = \prod_{k=1}^{\infty} (\sum_{i=0}^{k^2} x^i)$

11. (a) The coefficient of  $x^{20}$  in  $(x + x^2 + \dots)^{12} = x^{12}(1 + x + x^2 + \dots)^{12}$  is the coefficient of  $x^8$  in  $(1 + x + x^2 + \dots)^{12} = (1 - x)^{-12}$ , and this is  $\binom{-12}{8}(-1)^8 = (-1)^8 \binom{12+8-1}{8}(-1)^8 = \binom{19}{8}$ .

(b) The coefficient of  $x^{10}$  in  $(x + x^2 + \dots)^6 = x^6(1 + x + x^2 + \dots)^6$  is  $\binom{-6}{4}(-1)^4 = \binom{9}{4}$ . The probability for this type of distribution is  $\binom{9}{4} \binom{9}{4} / \binom{19}{8}$ .

12. Fix  $m$ ,  $0 \leq m \leq n$ . The  $m$  objects can be arranged in  $(k)(k+1)\cdots(k+m-1)$  ways. Since there are  $\binom{n}{m}$  ways to select  $m$  of these objects, there are  $\binom{n}{m}(k)(k+1)\cdots(k+m-1)$  ways to select  $m$  of the  $n$  objects and place them in the containers as prescribed.

$e^x/(1-x)^k = [1 + x + (x^2/2!) + (x^3/3!) + \dots] \cdot [\binom{-k}{0} + \binom{-k}{1}(-x) + \binom{-k}{2}(-x)^2 + \dots]$ . The coefficient of  $x^n/n!$  in  $e^x(1-x)^{-k}$  is  $\binom{-k}{0} + \binom{-k}{1}(-1)(n) + \binom{-k}{2}(-1)^2(n)(n-1) + \dots + \binom{-k}{n-1}(-1)^{n-1}(n!/1!) + \binom{-k}{n}(-1)^n(n!/0!) = \sum_{m=0}^n \binom{-k}{m}(-1)^m \frac{n!}{(n-m)!} = \sum_{m=0}^n \binom{m+k-1}{m} \frac{n!}{(n-m)!}$ , and  $\sum_{m=0}^n \binom{n}{m}(k)(k+1)\cdots(k+m-1) = \sum_{m=0}^n \frac{n!}{m!(n-m)!} \frac{(m+k-1)!}{(k-1)!} = \sum_{m=0}^n \frac{(m+k-1)!}{m!(k-1)!} \frac{n!}{(n-m)!} = \sum_{m=0}^n \binom{m+k-1}{m} \frac{n!}{(n-m)!}$ .

13. (a) We start with  $a + (d-a)x$ , the generating function for the sequence  $a, d-a, 0, 0, 0, \dots$ . Then  $[a + (d-a)x]/(1-x)$  is the generating function for the sequence  $a, a + (d-a), a + (d-a) + 0, a + (d-a) + 0 + 0, \dots$  - that is, the sequence  $a, d, d, d, \dots$ . Consequently,  $[a + (d-a)x]/(1-x)^2$  generates the sequence  $a, a + d, a + d + d, a + d + d + d, \dots$  - that is, the sequence  $a, a + d, a + 2d, a + 3d, \dots$ . [Note: Part (c) of Exercise 1 for Section 9.5 is a special case of this result: Let  $a = 1, d = 3$ .]

(b) Here we need the coefficient of  $x^{n-1}$  in  $(1/(1-x))[a + (d-a)x]/(1-x)^2 = [a + (d-a)x]/(1-x)^3 = [a + (d-a)x](1-x)^{-3}$ . This coefficient is  $a \binom{-3}{n-1}(-1)^{n-1} + (d-a) \binom{-3}{n-2}(-1)^{n-2} = a(-1)^{n-1} \binom{3+(n-1)-1}{n-1}(-1)^{n-1} + (d-a)(-1)^{n-2} \binom{3+(n-2)-1}{n-2}(-1)^{n-2} = a \binom{n+1}{n-1} + (d-a) \binom{n-2}{n-2} = a(\frac{1}{2})(n+1)(n) + (d-a)(\frac{1}{2})(n)(n-1) = a(\frac{1}{2})(n)[(n+1) - (n-1)] + d(\frac{1}{2})(n)(n-1) = na + (\frac{1}{2})(n)(n-1)d$ .

[The reader may wish to compare this with the result for the first Supplementary Exercise in Chapter 4.]

14. (a) For  $n \in \mathbf{N}$ ,  $a_n = |\sum^n| = 2^n$ , and the generating function for  $2^0, 2^1, 2^2, 2^3, \dots$ , is  $f(x) = 1 + 2x + 4x^2 + 8x^3 + \dots = 1 + (2x) + (2x)^2 + (2x)^3 + \dots = \frac{1}{1-2x}$ .

(b) When  $|\sum| = k$ , for  $k$  a fixed positive integer, we have  $a_n = k^n$  and the generating function is  $g(x) = 1 + kx + k^2x^2 + \dots = 1 + (kx) + (kx)^2 + \dots = \frac{1}{1-kx}$ .

15. (a)  $x^n f(x)$

(b)  $[f(x) - (a_0 + a_1x + a_2x^2 + \dots + a_{n-1}x^{n-1})]/x^n$

16. (a)  $1 = \sum_{x=0}^{\infty} k(\frac{1}{4})^x = k[1 + \frac{1}{4} + (\frac{1}{4})^2 + \dots] = k[\frac{1}{1-(1/4)}] = k[1/(3/4)] = (4/3)k$ , so  $k = 3/4$ .

$$(b) \Pr(X = 3) = (3/4)(1/4)^3 = 3/256$$

$$\Pr(X \leq 3) = \sum_{x=0}^3 \Pr(X = x) = (3/4)[1 + (1/4) + (1/4)^2 + (1/4)^3] = (3/4)(85/64) = 255/256$$

$$\Pr(X > 3) = 1 - \Pr(X \leq 3) = 1 - (255/256) = 1/256$$

$$[\text{Alternately, } \Pr(X > 3) = \Pr(X \geq 4) = \sum_{x=4}^{\infty} \Pr(X = x) = (3/4)[(1/4)^4 + (1/4)^5 + (1/4)^6 + \dots]$$

$$= (3/4)(1/4)^4[1 + (1/4) + (1/4)^2 + \dots] = (3/4)(1/4)^4[\frac{1}{1-(1/4)}] = (1/4)^4 = 1/256.]$$

$$\Pr(X \geq 2) = \sum_{x=2}^{\infty} \Pr(X = x) = \sum_{x=2}^{\infty} (3/4)(1/4)^x$$

$$= (3/4)(1/4)^2[1 + (1/4) + (1/4)^2 + \dots] = (3/64)[\frac{1}{1-(1/4)}] = (1/4)^2 = 1/16.$$

$$(c) \text{ For } n \in \mathbf{Z}^+, \Pr(X \geq n) = \sum_{x=n}^{\infty} \Pr(X = x) = \sum_{x=n}^{\infty} (3/4)(1/4)^x =$$

$$(3/4)(1/4)^n \sum_{i=0}^{\infty} (1/4)^i = (1/4)^n.$$

$$\text{Consequently, } \Pr(x \geq 4 | X \geq 2) = \frac{\Pr(X \geq 4 \text{ and } X \geq 2)}{\Pr(X \geq 2)} = \Pr(X \geq 4) / \Pr(X \geq 2) =$$

$$(1/4)^4 / (1/4)^2 = (1/4)^2. \text{ Likewise } \Pr(X \geq 104 | X \geq 102) = (1/4)^2.$$

17. For  $k \in \mathbf{Z}^+$ ,  $k$  fixed, we find that  $\Pr(Y \geq k) = \sum_{y=k}^{\infty} q^{y-1} p$  (where  $q = 1 - p$ )  
 $= q^{k-1} p + q^k p + q^{k+1} p + \dots = q^{k-1} p [1 + q + q^2 + \dots]$   
 $= q^{k-1} p \frac{1}{(1-q)} = q^{k-1} p (\frac{1}{p}) = q^{k-1}$ . Consequently,  $\Pr(Y \geq m | Y \geq n) = \Pr(Y \geq m \text{ and } Y \geq n) / \Pr(Y \geq n) = \Pr(Y \geq m) / \Pr(Y \geq n) = q^{m-1} / q^{n-1} = q^{m-n}$ . [This property is the reason why a geometric random variable is said to be *memoryless*. In fact, the geometric random variable is the only discrete random variable with this property.]
18. (a) The car travels the first mile in one hour, the second mile in  $1/2$  hour, the third mile in  $1/4$  [=  $(1/2)^2$ ] hour, and the fourth mile in  $1/8$  [=  $(1/2)^3$ ] hour. Consequently, the average velocity for the first four miles is  $4 / [1 + (1/2) + (1/2)^2 + (1/2)^3] = 4 / [1 - (1/2)^4] / [1 - (1/2)] = 4 / [2(15/16)] = 32/15 = 2\frac{2}{15}$  miles per hour.
- (b) The average velocity for the first  $n$  miles is  $n / [1 + (1/2) + (1/2)^2 + \dots + (1/2)^{n-1}] = n / [1 - (1/2)^n] / [1 - (1/2)] = n / [2((2^n - 1)/2^n)] = n(2^{n-1}) / [2^n - 1]$  miles per hour.
- (c) For  $n = 19$  the average velocity is  $4980736/524287 \doteq 9.500018120$  miles per hour. For  $n = 20$  the average velocity is  $2097152/209715 \doteq 10.00000954$  miles per hour. Hence the smallest value of  $n$  for which the average velocity for the first  $n$  miles exceeds 10 miles per hour is  $n = 20$ .

CHAPTER 10  
RECURRENCE RELATIONS

**Section 10.1**

1. (a)  $a_n = 5a_{n-1}, n \geq 1, a_0 = 2$  (c)  $a_n = (2/5)a_{n-1}, n \geq 1, a_0 = 7$   
 (b)  $a_n = -3a_{n-1}, n \geq 1, a_0 = 6$
2. (a)  $a_{n+1} = 1.5a_n, a_n = (1.5)^n a_0, n \geq 0.$   
 (b)  $4a_n = 5a_{n-1}, a_n = (1.25)^n a_0, n \geq 0.$   
 (c)  $3a_{n+1} = 4a_n, 3a_1 = 15 = 4a_0, a_0 = 15/4, \text{ so}$   
 $a_n = (4/3)^n a_0 = (4/3)^n (15/4) = 5(4/3)^{n-1}, n \geq 0.$   
 (d)  $a_n = (3/2)a_{n-1}, a_n = (3/2)^n a_0, 81 = a_4 = (3/2)^4 a_0 \text{ so } a_0 = 16 \text{ and } a_n =$   
 $(16)(3/2)^n, n \geq 0.$
3.  $a_{n+1} - da_n = 0, n \geq 0, \text{ so } a_n = d^n a_0. 153/49 = a_3 = d^3 a_0, 1377/2401 = a_5 = d^5 a_0 \implies$   
 $a_5/a_3 = d^2 = 9/49 \text{ and } d = \pm 3/7.$
4.  $a_{n+1} = a_n + 2.5a_n, n \geq 0.$   
 $a_n = (3.5)^n a_0 = (3.5)^n (1000). \text{ For } n = 12, a_n = (3.5)^{12} (1000) \doteq 3,379,220,508.$
5.  $P_n = 100(1 + 0.015)^n, P_0 = 100$   
 $200 = 100(1.015)^n \implies 2 = (1.015)^n$   
 $(1.015)^{46} \doteq 1.9835 \text{ and } (1.015)^{47} \doteq 2.0133.$   
 Hence Laura must wait  $(47)(3) = 141$  months for her money to double.
6.  $P_n = P_0(1.02)^n$   
 $7218.27 = P_0(1.02)^{60}, \text{ so } P_0 = (7218.27)(1.02)^{-60} = \$2200.00$
7. (a)  $19 + 18 + 17 + \dots + 10 = 145$   
 (b)  $9 + 8 + 7 + \dots + 1 = 45$
8. (a) Suppose that for  $i = k$ , where  $1 \leq k \leq n - 2$ , no interchanges result (for the first time) in the execution of the inner for loop. Up to this point the number of executions that have been made is  $(n-1) + (n-2) + \dots + (n-k)$ . If we continue and execute the inner for loop for  $k+1 \leq i \leq n-1$ , then we make  $[n - (k+1)] + [n - (k+2)] + \dots + 3 + 2 + 1 = (1/2)(n-k-1)(n-k)$  unnecessary comparisons. [Note:  $(n-1) + (n-2) + \dots + (n-k) = kn - (1+2+3+\dots+k) = kn - (1/2)(k)(k+1)$  and  $(1/2)(n-1)(n) - [kn - (1/2)(k)(k+1)] = (1/2)(n-k-1)(n-k)$ ]

(b) The input for the following procedure is an array  $A$  of  $n$  real numbers. The output is the reordered array  $A$  with  $A[1] \leq A[2] \leq \dots \leq A[n]$ .

```

Procedure BubbleSort2(var A: array; n: integer);
Var
    Switch: boolean; {The value of Switch is true if}
                    {an interchange actually takes place.}
    ij: integer;
    temp: real;
Begin
    Switch := true;
    While Switch do
        Begin
            Switch := false;
            For i := 1 to n-1 do
                For j := n downto i+1 do
                    If A[j] < A[j-1] then
                        Begin
                            temp := A[j-1];
                            A[j-1] := A[j];
                            A[j] := temp;
                            Switch := true
                        End {if}
                    End {while}
        End. {procedure}

```

(c) The best case occurs when the array  $A$  is already in nondecreasing order. When this happens the procedure is only processed for  $i := 1$  and  $j := n$  down to 2. This results in  $n - 1$  comparisons so the best-case complexity is  $O(n)$ .

The worst case occurs when a Switch is made for all  $i := 1$  to  $n - 1$ . This results (as in Example 10.5) in  $(n^2 - n)/2$  comparisons, so the worst-case complexity is  $O(n^2)$ .

9. (a) 21345 (b) 52143, 52134, 25134  
(c) 25134, 21534, 21354, 21345

10. (a) 1,2,3 3,1,2  
1,3,2 3,2,1  
(b) 1,2,3,4 4,1,2,3  
1,2,4,3 4,1,3,2  
1,4,2,3 4,3,1,2  
1,4,3,2 4,3,2,1

(c) The value of  $p_1$  is either 1 or 5.

(d) Let  $p_1, p_2, p_3, \dots, p_n$  be an orderly permutation of  $1, 2, 3, \dots, n$ . Then  $p_1$  is either 1 or  $n$ . If  $p_1 = 1$ , then  $p_2 - 1, p_3 - 1, \dots, p_n - 1$  is an orderly permutation of  $1, 2, 3, \dots, n - 1$ . For  $p_1 = n$  we find that  $p_2, p_3, \dots, p_n$  is an orderly permutation of  $1, 2, 3, \dots, n - 1$ . Since these two cases are exhaustive and have nothing in common we may write

$$a_n = 2a_{n-1}, \quad n \geq 3, \quad a_2 = 2.$$

Hence,  $a_3 = 2a_2 = 2 \cdot 2 = 2^2,$

$$a_4 = 2a_3 = 2 \cdot 2^2 = 2^3,$$

and, in general,

$$a_n = 2^{n-1}, \quad n \geq 2.$$

## Section 10.2

1. (a)  $a_n = 5a_{n-1} + 6a_{n-2}, \quad n \geq 2, \quad a_0 = 1, \quad a_1 = 3.$

Let  $a_n = cr^n, \quad c, r \neq 0$ . Then the characteristic equation is  $r^2 - 5r - 6 = 0 = (r - 6)(r + 1)$ , so  $r = -1, 6$  are the characteristic roots.

$$a_n = A(-1)^n + B(6)^n$$

$$1 = a_0 = A + B$$

$$3 = a_1 = -A + 6B, \text{ so } B = 4/7 \text{ and } A = 3/7.$$

$$a_n = (3/7)(-1)^n + (4/7)(6)^n, \quad n \geq 0.$$

(b)  $a_n = 4(1/2)^n - 2(5)^n, \quad n \geq 0.$

(c)  $a_{n+2} + a_n = 0, \quad n \geq 0, \quad a_0 = 0, \quad a_1 = 3.$

With  $a_n = cr^n, \quad c, r \neq 0$ , the characteristic equation  $r^2 + 1 = 0$  yields the characteristic roots  $\pm i$ . Hence  $a_n = A(i)^n + B(-i)^n = A(\cos(\pi/2) + i \sin(\pi/2))^n + B(\cos(\pi/2) + i \sin(-\pi/2))^n = C \cos(n\pi/2) + D \sin(n\pi/2)$ .

$$0 = a_0 = C, \quad 3 = a_1 = D \sin(\pi/2) = D, \text{ so } a_n = 3 \sin(n\pi/2), \quad n \geq 0.$$

(d)  $a_n - 6a_{n-1} + 9a_{n-2} = 0, \quad n \geq 2, \quad a_0 = 5, \quad a_1 = 12.$

Let  $a_n = cr^n, \quad c, r \neq 0$ . Then  $r^2 - 6r + 9 = 0 = (r - 3)^2$ , so the characteristic roots are  $3, 3$  and  $a_n = A(3^n) + Bn(3^n)$ .

$$5 = a_0 = A; \quad 12 = a_1 = 3A + 3B = 15 + 3B, \quad B = -1.$$

$$a_n = 5(3^n) - n(3^n) = (5 - n)(3^n), \quad n \geq 0.$$

(e)  $a_n + 2a_{n-1} + 2a_{n-2} = 0, \quad n \geq 2, \quad a_0 = 1, \quad a_1 = 3.$

$$r^2 + 2r + 2 = 0, \quad r = -1 \pm i$$

$$(-1 + i) = \sqrt{2}(\cos(3\pi/4) + i \sin(3\pi/4))$$

$$(-1 - i) = \sqrt{2}(\cos(5\pi/4) + i \sin(5\pi/4)) =$$

$$\sqrt{2}(\cos(-3\pi/4) + i \sin(-3\pi/4)) = \sqrt{2}(\cos(3\pi/4) - i \sin(3\pi/4))$$

$$a_n = (\sqrt{2})^n \{A \cos(3\pi n/4) + B \sin(3\pi n/4)\}$$

$$1 = a_0 = A$$

$$3 = a_1 = \sqrt{2}[\cos(3\pi/4) + B \sin(3\pi/4)] =$$

$$\sqrt{2}[(-1/\sqrt{2}) + B(1/\sqrt{2})], \text{ so } 3 = -1 + B, B = 4$$

$$a_n = (\sqrt{2})^n [\cos(3\pi n/4) + 4 \sin(3\pi n/4)], n \geq 0$$

2. (a) Example 10.14:  $a_n = 10a_{n-1} + 29a_{n-2}, n \geq 2, a_1 = 10, a_2 = 100.$

$$r^2 - 10r - 29 = 0, r = 5 \pm 6\sqrt{6}.$$

$$a_n = A(5 + 6\sqrt{6})^n + B(5 - 6\sqrt{6})^n$$

$$a_2 = 100 = 10a_1 + 29a_0 = 100 + 29a_0, \text{ so } a_0 = 0$$

$$0 = a_0 = A + B, \text{ so } B = -A.$$

$$a_n = A[(5 + 6\sqrt{6})^n - (5 - 6\sqrt{6})^n]$$

$$10 = a_1 = A[5 + 6\sqrt{6} - 5 + 6\sqrt{6}] = 12\sqrt{6}A, A = 5/6\sqrt{6}.$$

$$a_n = (5/6\sqrt{6})[(5 + 6\sqrt{6})^n - (5 - 6\sqrt{6})^n], n \geq 0.$$

Example 10.23:  $a_n = c_1(2^n) + c_2n(2^n), n \geq 0, a_0 = 1, a_1 = 3.$

$$a_0 = 1 = c_1; a_1 = 3 = 2 + c_2(2), c_2 = 1/2.$$

$$a_n = (2^n)[1 + (n/2)], n \geq 0.$$

- (b) Example 10.16:  $a_n = a_{n-1} + a_{n-2}, n \geq 2, a_0 = 1, a_1 = 2.$

$$r^2 - r - 1 = 0, r = (1 \pm \sqrt{5})/2.$$

$$a_0 = 1 = A + B$$

$$a_1 = 2 = A[(1 + \sqrt{5})/2] + B[(1 - \sqrt{5})/2]$$

$$4 = A(1 + \sqrt{5}) + B(1 - \sqrt{5}) = (A + B) + \sqrt{5}(A - B) = 1 + \sqrt{5}(A - B), \text{ so } 3 = \sqrt{5}(A - B)$$

$$\text{and } A - B = 3/\sqrt{5}.$$

$$2A = (A + B) + (A - B) = 1 + 3/\sqrt{5} = (3 + \sqrt{5})/\sqrt{5}, A = (3 + \sqrt{5})/2\sqrt{5}; B = 1 - A = (\sqrt{5} - 3)/2\sqrt{5},$$

$$a_n = [(\sqrt{5} + 3)/2\sqrt{5}][(1 + \sqrt{5})/2]^n + [(\sqrt{5} - 3)/2\sqrt{5}][(1 - \sqrt{5})/2]^n, n \geq 0$$

3. ( $n = 0$ ):  $a_2 + ba_1 + ca_0 = 0 = 4 + b(1) + c(0), \text{ so } b = -4.$

$$(n = 1): a_3 - 4a_2 + ca_1 = 0 = 37 - 4(4) + c, \text{ so } c = -21.$$

$$a_{n+2} - 4a_{n+1} - 21a_n = 0$$

$$r^2 - 4r - 21 = 0 = (r - 7)(r + 3), r = 7, -3$$

$$a_n = A(7)^n + B(-3)^n$$

$$0 = a_0 = A + B \implies B = -A$$

$$1 = a_1 = 7A - 3B = 10A, \text{ so } A = 1/10, B = -1/10 \text{ and } a_n = (1/10)[(7)^n - (-3)^n], n \geq 0.$$

4.  $a_n = a_{n-1} + a_{n-2}, n \geq 2, a_0 = a_1 = 1$

$$r^2 - r - 1 = 0, r = (1 \pm \sqrt{5})/2$$

$$a_n = A((1 + \sqrt{5})/2)^n + B((1 - \sqrt{5})/2)^n$$

$$a_0 = a_1 = 1 \implies A = (1 + \sqrt{5})/2\sqrt{5}, B = (\sqrt{5} - 1)/2\sqrt{5}$$

$$a_n = (1/\sqrt{5})[((1 + \sqrt{5})/2)^{n+1} - ((1 - \sqrt{5})/2)^{n+1}]$$

5. For all three parts, let  $a_n, n \geq 0$ , count the number of ways to fill the  $n$  spaces under the condition(s) specified.

(a) Here  $a_0 = 1$  and  $a_1 = 2$ . For  $n \geq 2$ , consider the  $n$ th space. If this space is occupied by a motorcycle - in one of two ways, then we have  $2a_{n-1}$  of the ways to fill the  $n$  spaces.

Further, there are  $a_{n-2}$  ways to fill the  $n$  spaces when a compact car occupies positions  $n-1$  and  $n$ . These two cases are exhaustive and have nothing in common, so

$$a_n = 2a_{n-1} + a_{n-2}, \quad n \geq 2, \quad a_0 = 1, \quad a_1 = 2.$$

Let  $a_n = cr^n$ ,  $c \neq 0$ ,  $r \neq 0$ . Upon substitution we have  $r^2 - 2r - 1 = 0$ , so  $r = 1 \pm \sqrt{2}$  and  $a_n = c_1(1 + \sqrt{2})^n + c_2(1 - \sqrt{2})^n$ ,  $n \geq 0$ . From  $1 = a_0 = c_1 + c_2$  and  $2 = a_1 = c_1(1 + \sqrt{2}) + c_2(1 - \sqrt{2})$ , we have  $c_1 = \frac{2+\sqrt{2}}{4}$  and  $c_2 = \frac{2-\sqrt{2}}{4}$ . So  $a_n = ((\sqrt{2} + 2)/4)(1 + \sqrt{2})^n + ((2 - \sqrt{2})/4)(1 - \sqrt{2})^n = (1/2\sqrt{2})[(1 + \sqrt{2})^{n+1} - (1 - \sqrt{2})^{n+1}]$ ,  $n \geq 0$ .

(b) Here  $a_0 = 1$  and  $a_1 = 1$ . For  $n \geq 2$ , consider the  $n$ th space. This space can be occupied by a motorcycle in one way and accounts for  $a_{n-1}$  of the  $a_n$  ways to fill the  $n$  spaces. If a compact car occupies the  $(n-1)$ st and  $n$ th spaces, then we have the remaining  $3a_{n-2}$  ways to fill  $n$  spaces. So here  $a_n = a_{n-1} + 3a_{n-2}$ ,  $n \geq 2$ ,  $a_0 = 1$ ,  $a_1 = 1$ .

Let  $a_n = cr^n$ ,  $c \neq 0$ ,  $r \neq 0$ . Upon substitution we have  $r^2 - r - 3 = 0$ , so  $r = (1 \pm \sqrt{13})/2$ , and  $a_n = c_1[(1 + \sqrt{13})/2]^n + c_2[(1 - \sqrt{13})/2]^n$ ,  $n \geq 0$ . From  $1 = a_0 = c_1 + c_2$  and  $1 = a_1 = c_1[(1 + \sqrt{13})/2] + c_2[(1 - \sqrt{13})/2]$ , we find that  $c_1 = [(1 + \sqrt{13})/2\sqrt{13}]$  and  $c_2 = [(-1 + \sqrt{13})/2\sqrt{13}]$ . So  $a_n = (1/\sqrt{13})[(1 + \sqrt{13})/2]^{n+1} - (1/\sqrt{13})[(1 - \sqrt{13})/2]^{n+1}$ ,  $n \geq 0$ .

(c) Comparable to parts (a) and (b), here we have  $a_n = 2a_{n-1} + 3a_{n-2}$ ,  $n \geq 2$ ,  $a_0 = 1$ ,  $a_1 = 2$ . Substituting  $a_n = cr^n$ ,  $c \neq 0$ ,  $r \neq 0$ , into the recurrence relation, we find that  $r^2 - 2r - 3 = 0$  so  $(r-3)(r+1) = 0$  and  $r = 3$ ,  $r = -1$ . Consequently,  $a_n = c_1(3^n) + c_2(-1)^n$ ,  $n \geq 0$ . From  $1 = a_0 = c_1 + c_2$  and  $2 = a_1 = 3c_1 - c_2$ , we learn that  $c_1 = 3/4$  and  $c_2 = 1/4$ . Therefore,  $a_n = (3/4)(3^n) + (1/4)(-1)^n$ ,  $n \geq 0$ .

6. For all three parts, let  $b_n$ ,  $n \geq 0$ , count the number of ways to fill the  $n$  spaces under the condition(s) specified - including the condition allowing empty spaces.

(a) Here  $b_0 = 1$ ,  $b_1 = 3$ , and  $b_n = 3b_{n-1} + b_{n-2}$ ,  $n \geq 2$ . This recurrence relation leads us to the characteristic equation  $r^2 - 3r - 1 = 0$ , and the characteristic roots  $r = (3 \pm \sqrt{13})/2$ . Consequently,  $b_n = c_1[(3 + \sqrt{13})/2]^n + c_2[(3 - \sqrt{13})/2]^n$ ,  $n \geq 0$ . From  $1 = b_0 = c_1 + c_2$  and  $3 = b_1 = c_1[(3 + \sqrt{13})/2] + c_2[(3 - \sqrt{13})/2]$ , we find that  $c_1 = (3 + \sqrt{13})/2\sqrt{13}$  and  $c_2 = (-3 + \sqrt{13})/2\sqrt{13}$ . So  $b_n = (1/\sqrt{13})[(3 + \sqrt{13})/2]^{n+1} - (1/\sqrt{13})[(3 - \sqrt{13})/2]^{n+1}$ ,  $n \geq 0$ .

(b) For this part we have  $b_n = 2b_{n-1} + 3b_{n-2}$ ,  $n \geq 0$ ,  $b_0 = 1$ ,  $b_1 = 2$ . Here the characteristic equation is  $r^2 - 2r - 3 = 0$  and the characteristic roots are  $r = 3$ ,  $r = -1$ . Therefore,  $b_n = c_1(3^n) + c_2(-1)^n$ ,  $n \geq 0$ . From  $1 = b_0 = c_1 + c_2$  and  $2 = b_1 = 3c_1 - c_2$ , we find that  $c_1 = 3/4$ ,  $c_2 = 1/4$ . So  $b_n = (3/4)(3^n) + (1/4)(-1)^n$ ,  $n \geq 0$ .

(c) Here  $b_0 = 1$ ,  $b_1 = 3$ , and  $b_n = 3b_{n-1} + 3b_{n-2}$ ,  $n \geq 2$ . The characteristic equation  $r^2 = 3r + 3$  gives us the characteristic roots  $r = (3 \pm \sqrt{21})/2$ . So  $b_n = c_1[(3 + \sqrt{21})/2]^n + c_2[(3 - \sqrt{21})/2]^n$ ,  $n \geq 0$ . From  $1 = b_0 = c_1 + c_2$  and  $3 = b_1 = c_1[(3 + \sqrt{21})/2] + c_2[(3 - \sqrt{21})/2]$ , we have  $c_1 = [(3 + \sqrt{21})/2\sqrt{21}]$  and  $c_2 = [(-3 + \sqrt{21})/2\sqrt{21}]$ . Consequently,  $b_n = (1/\sqrt{21})[(3 + \sqrt{21})/2]^{n+1} - ((3 - \sqrt{21})/2)^{n+1}$ ,  $n \geq 0$ .

7. (a)

$$\begin{aligned} F_1 &= F_2 - F_0 \\ F_3 &= F_4 - F_2 \\ F_5 &= F_6 - F_4 \\ \dots & \quad \dots \quad \dots \\ F_{2n-1} &= F_{2n} - F_{2n-2} \end{aligned}$$

Conjecture: For all  $n \in \mathbf{Z}^+$ ,  $F_1 + F_3 + F_5 + \dots + F_{2n-1} = F_{2n} - F_0 = F_{2n}$ .

Proof: (By the Principle of Mathematical Induction).

For  $n = 1$  we have  $F_1 = F_2$ , and this is true since  $F_1 = 1 = F_2$ . Consequently, the result is true in this first case (and this establishes the basis step for the proof).

Next we assume the result true for  $n = k$  ( $\geq 1$ ) – that is, we assume

$$F_1 + F_3 + F_5 + \dots + F_{2k-1} = F_{2k}.$$

When  $n = k + 1$  we then find that

$$F_1 + F_3 + F_5 + \dots + F_{2k-1} + F_{2(k+1)-1} =$$

$$(F_1 + F_3 + F_5 + \dots + F_{2k-1}) + F_{2k+1} = F_{2k} + F_{2k+1} = F_{2k+2} = F_{2(k+1)}.$$

Therefore the truth for  $n = k$  implies the truth at  $n = k + 1$ , so by the Principle of Mathematical Induction it follows that for all  $n \in \mathbf{Z}^+$

$$F_1 + F_3 + F_5 + \dots + F_{2n-1} = F_{2n}.$$

(b)

$$\begin{aligned} F_2 &= F_3 - F_1 \\ F_4 &= F_5 - F_3 \\ F_6 &= F_7 - F_5 \\ \dots & \quad \dots \quad \dots \\ F_{2n} &= F_{2n+1} - F_{2n-1} \end{aligned}$$

Conjecture: For all  $n \in \mathbf{N}$ ,  $F_2 + F_4 + \dots + F_{2n} = F_0 + F_2 + F_4 + \dots + F_{2n} = F_{2n+1} - F_1 = F_{2n+1} - 1$ .

Proof: (By the Principle of Mathematical Induction)

When  $n = 0$  we find that  $0 = F_0 = F_1 - F_1 = 0$ , so the result is true for this initial case, and this provides the basis step for the proof.

Assuming the result true for  $n = k$  ( $\geq 0$ ) we have  $\sum_{i=0}^k F_{2i} = F_{2k+1} - 1$ . Then when  $n = k + 1$

it follows that  $\sum_{i=0}^{k+1} F_{2i} = \sum_{i=0}^k F_{2i} + F_{2(k+1)} = F_{2k+1} - 1 + F_{2k+2} = (F_{2k+2} + F_{2k+1}) - 1 = F_{2k+3} - 1 = F_{2(k+1)+1} - 1$ . Consequently we see how the truth of the result for  $n = k$  implies the truth of the result for  $n = k + 1$ . Therefore it follows that for all  $n \in \mathbf{N}$ .

$$F_0 + F_2 + F_4 + \dots + F_{2n} = F_{2n+1} - 1,$$

by the Principle of Mathematical Induction.

$$\begin{aligned}
 8. \quad (a) \quad \lim_{n \rightarrow \infty} \frac{F_{n+1}}{F_n} &= \lim_{n \rightarrow \infty} \frac{(1/\sqrt{5})\left[\left(\frac{1+\sqrt{5}}{2}\right)^{n+1} - \left(\frac{1-\sqrt{5}}{2}\right)^{n+1}\right]}{(1/\sqrt{5})\left[\left(\frac{1+\sqrt{5}}{2}\right)^n - \left(\frac{1-\sqrt{5}}{2}\right)^n\right]} \\
 &= \lim_{n \rightarrow \infty} \frac{\left[\left(\frac{1+\sqrt{5}}{2}\right)^{n+1} - \left(\frac{1-\sqrt{5}}{2}\right)^{n+1}\right]}{\left[\left(\frac{1+\sqrt{5}}{2}\right)^n - \left(\frac{1-\sqrt{5}}{2}\right)^n\right]} \\
 &= \lim_{n \rightarrow \infty} \frac{\alpha^{n+1} - \beta^{n+1}}{\alpha^n - \beta^n} \quad (\text{where } \alpha = \frac{1+\sqrt{5}}{2}, \beta = \frac{1-\sqrt{5}}{2}) \\
 &= \lim_{n \rightarrow \infty} \frac{1 - \left(\frac{\beta}{\alpha}\right)^{n+1}}{\left(\frac{1}{\alpha}\right) - \left(\frac{\beta}{\alpha}\right)\left(\frac{\beta}{\alpha}\right)^n}
 \end{aligned}$$

Since  $|\beta| < 1$  and  $|\alpha| > 1$ , it follows that  $|\frac{\beta}{\alpha}| < 1$  and  $|\frac{\beta}{\alpha}|^n \rightarrow 0$  as  $n \rightarrow \infty$ .

Consequently,  $\lim_{n \rightarrow \infty} \frac{F_{n+1}}{F_n} = \frac{1}{\left(\frac{1}{\alpha}\right)} = \alpha = \frac{1+\sqrt{5}}{2}$ .

$$(b) \quad (i) \quad AC/AX = \sin AXC / \sin ACX = \sin 108^\circ / \sin 36^\circ = 2 \sin 36^\circ \cos 36^\circ / \sin 36^\circ = 2 \cos 36^\circ$$

$$(ii) \quad \cos 18^\circ = \sin 72^\circ = 2 \sin 36^\circ \cos 36^\circ =$$

$$2(2 \sin 18^\circ \cos 18^\circ)(1 - 2 \sin^2 18^\circ) \implies 1 =$$

$$4 \sin 18^\circ (1 - 2 \sin^2 18^\circ) = 4 \sin 18^\circ - 8 \sin^3 18^\circ.$$

$$0 = 8 \sin^3 18^\circ - 4 \sin 18^\circ + 1, \text{ so } \sin 18^\circ \text{ is a root of } 8x^3 - 4x + 1 = 0.$$

$$8x^3 - 4x + 1 = (2x - 1)(4x^2 + 2x - 1) = 0.$$

$$\text{The roots of } 4x^2 + 2x - 1 = 0 \text{ are } (-1 \pm \sqrt{5})/4.$$

$$\text{Since } 0 < \sin 18^\circ < \sin 30^\circ = 1/2, \sin 18^\circ = (-1 + \sqrt{5})/4.$$

$$(c) \quad (1/2)(AC/AX) = \cos 36^\circ = 1 - 2 \sin^2 18^\circ = 1 - 2\left[(-1 + \sqrt{5})/4\right]^2 = (1 + \sqrt{5})/4.$$

$$AC/AX = 2(1 + \sqrt{5})/4 = (1 + \sqrt{5})/2.$$

$$9. \quad a_n = a_{n-1} + a_{n-2}, \quad n \geq 0, \quad a_0 = a_1 = 1$$

(Append '+1') (Append '+2')

$$a_n = A\left[\left(\frac{1+\sqrt{5}}{2}\right)^n + B\left[\left(\frac{1-\sqrt{5}}{2}\right)^n\right]\right]$$

$$1 = a_0 = A + B; \quad 1 = a_1 = A\left(\frac{1+\sqrt{5}}{2}\right) + B\left(\frac{1-\sqrt{5}}{2}\right) \text{ or}$$

$$2 = (A + B) + \sqrt{5}(A - B) = 1 + \sqrt{5}(A - B) \text{ and } A - B = 1/\sqrt{5}.$$

$$1 = A + B, \quad 1/\sqrt{5} = A - B \implies A = (1 + \sqrt{5})/2\sqrt{5}, \quad B = (\sqrt{5} - 1)/2\sqrt{5} \text{ and } a_n = (1/\sqrt{5})\left[\left(\frac{1+\sqrt{5}}{2}\right)^{n+1} - \left(\frac{1-\sqrt{5}}{2}\right)^{n+1}\right], \quad n \geq 0.$$

10. Here  $a_1 = 1$  and  $a_2 = 1$ . For  $n \geq 3$ ,  $a_n = a_{n-1} + a_{n-2}$ , because the strings counted by  $a_n$  either end in 1 (and there are  $a_{n-1}$  such strings) or they end in 00 (and there are  $a_{n-2}$  such strings).

Consequently,  $a_n = F_n$ , the  $n$ th Fibonacci number, for  $n \geq 1$ .

11. a) The solution here is similar to that for part (b) of Example 10.16. For  $n = 1$ , there are two strings - namely, 0 and 1. When  $n = 2$ , we find three such strings: 00, 10, 01. For  $n \geq 3$ , we can build the required strings of length  $n$  (1) by appending '0' to each of the  $a_{n-1}$  strings of length  $n - 1$ ; or (2) by appending '01' to each of the  $a_{n-2}$  strings of length

$n - 2$ . These two cases have nothing in common and cover all possibilities, so

$$a_n = a_{n-1} + a_{n-2}, \quad n \geq 3, a_1 = 2, a_2 = 3.$$

We find that  $a_n = F_{n+2} = (\alpha^{n+2} - \beta^{n+2})/(\alpha - \beta)$  where  $\alpha = (1 + \sqrt{5})/2$  and  $\beta = (1 - \sqrt{5})/2$ .  
 b) Here  $b_1 = 1$  since 0 is the only string of length 1 that satisfies both conditions. For  $n = 2$ , there are three strings: 00, 10, and 01 - so  $b_2 = 3$ . For  $n \geq 3$ , consider the bit in the  $n$ th position of such a binary string of length  $n$ .

- (1) If the  $n$ th bit is a 0, then there are  $a_{n-1}$  possibilities for the remaining  $n - 1$  bits.
- (2) If the  $n$ th bit is a 1, then the  $(n - 1)$ st and 1st bits are 0, and so there are  $a_{n-3}$  possibilities for the remaining  $n - 3$  bits.

Hence  $b_n = a_{n-1} + a_{n-3} = F_{n+1} + F_{n-1}$ , from part (a). So

$$b_n = (F_n + F_{n-1}) + (F_{n-2} + F_{n-3}) = (F_n + F_{n-2}) + (F_{n-1} + F_{n-3}) = b_{n-1} + b_{n-2}.$$

The characteristic equation  $x^2 - x - 1 = 0$  has characteristic roots  $\alpha = (1 + \sqrt{5})/2$  and  $\beta = (1 - \sqrt{5})/2$ , so  $b_n = c_1\alpha^n + c_2\beta^n$ . From  $1 = b_1 = c_1\alpha + c_2\beta$  and  $3 = b_2 = c_1\alpha^2 + c_2\beta^2$  we learn that  $c_1 = c_2 = 1$ . Hence  $b_n = \alpha^n + \beta^n = L_n$ , the  $n$ th Lucas number. [Recall that in Example 4.20 we showed that  $L_n = F_{n+1} + F_{n-1}$ .]

12. Let  $a_n$  count the number of ways to arrange  $n$  such chips with no consecutive blue chips. Let  $b_n$  equal the number of arrangements counted in  $a_n$  that end in blue;  $c_n = a_n - b_n$ .

Then  $a_{n+1} = 3b_n + 4c_n = 3(b_n + c_n) + c_n = 3a_n + 3a_{n-1}$ .

Hence  $a_{n+1} - 3a_n - 3a_{n-1} = 0$ ,  $n \geq 1$ ,  $a_0 = 1$ ,  $a_1 = 4$ . This recurrence relation has characteristic roots  $r = (3 \pm \sqrt{21})/2$  and  $a_n = A((3 + \sqrt{21})/2)^n + B((3 - \sqrt{21})/2)^n$ .

$a_0 = 1$ ,  $a_1 = 4 \implies A = (5 + \sqrt{21})/2\sqrt{21}$ ,  $B = (\sqrt{21} - 5)/2\sqrt{21}$  and

$$a_n = [(5 + \sqrt{21})/(2\sqrt{21})][(3 + \sqrt{21})/2]^n - [(5 - \sqrt{21})/(2\sqrt{21})][(3 - \sqrt{21})/2]^n, \quad n \geq 0.$$

13. For  $n \geq 0$ , let  $a_n$  count the number of words of length  $n$  in  $\Sigma^*$  where there are no consecutive alphabetic characters. Let  $a_n^{(1)}$  count those words that end with a numeric character, while  $a_n^{(2)}$  counts those that end with an alphabetic character. Then  $a_n = a_n^{(1)} + a_n^{(2)}$ .

$$\begin{aligned} \text{For } n \geq 1, \quad a_{n+1} &= 11a_n^{(1)} + 4a_n^{(2)} \\ &= \{4a_n^{(1)} + 4a_n^{(2)}\} + 7a_n^{(1)} \\ &= 4a_n + 7a_n^{(1)} \\ &= 4a_n + 7(4a_{n-1}) \\ &= 4a_n + 28a_{n-1}, \end{aligned}$$

and  $a_0 = 1$ ,  $a_1 = 11$ .

Now let  $a_n = cr^n$ , where  $c, r \neq 0$  and  $n \geq 0$ . Then the resulting characteristic equation is

$$r^2 - 4r - 28 = 0,$$

where  $r = (4 \pm \sqrt{128})/2 = 2 \pm 4\sqrt{2}$ .

Hence  $a_n = A[2 + 4\sqrt{2}]^n + B[2 - 4\sqrt{2}]^n$ ,  $n \geq 0$ .

$$\begin{aligned} 1 = a_0 &\Rightarrow 1 = A + B, \quad \text{and} \\ 11 = a_1 &\Rightarrow 11 = A[2 + 4\sqrt{2}] + B[2 - 4\sqrt{2}] \\ &= A[2 + 4\sqrt{2}] + (1 - A)[2 - 4\sqrt{2}] \\ &= [2 - 4\sqrt{2}] + A[2 + 4\sqrt{2} - 2 + 4\sqrt{2}] \\ &= [2 - 4\sqrt{2}] + 8\sqrt{2}A, \end{aligned}$$

so  $A = (9 + 4\sqrt{2})/(8\sqrt{2}) = (8 + 9\sqrt{2})/16$ , and  $B = 1 - A = (8 - 9\sqrt{2})/16$ .

Consequently,

$$a_n = [(8 + 9\sqrt{2})/16][2 + 4\sqrt{2}]^n + [(8 - 9\sqrt{2})/16][2 - 4\sqrt{2}]^n, \quad n \geq 0.$$

14. Using the ideas developed in the prior exercise we find that  $7k = 63$ , or  $k = 9$ .
15. Here we find that  
 $a_0 = 1$ ,  $a_1 = 2$ ,  $a_2 = 2$ ,  $a_3 = 2^2$ ,  $a_4 = 2^3$ ,  $a_5 = 2^5$ ,  $a_6 = 2^8$ ,  
 and, in general,  $a_n = 2^{F_n}$ , where  $F_n$  is the  $n$ th Fibonacci number for  $n \geq 0$ .
16.  $a_1 = 0$ ,  $a_2 = 1$ ,  $a_3 = 1$ . For  $n \geq 4$ , let  $n = x_1 + x_2 + \dots + x_t$ , where  $x_i \geq 2$  for  $1 \leq i \leq t$ , and  $1 \leq t \leq \lfloor n/2 \rfloor$ . If  $x_1 = 2$ , then  $x_2 + \dots + x_t$  is counted in  $a_{n-2}$ . If  $x_1 \neq 2$ , then  $x_1 > 2$  and  $(x_1 - 1) + x_2 + \dots + x_t$  is counted in  $a_{n-1}$ . Hence  $a_n = a_{n-1} + a_{n-2}$ ,  $n \geq 3$ , and  $a_n = F_{n-1}$ , the  $(n-1)$ -st Fibonacci number.
17. (a) From the previous exercise the number of compositions of  $n+3$  with no 1s as summands is  $F_{n+2}$ .  
 (b) (i) The number that start with 2 is the number of compositions of  $n+1$  with no 1s as summands. This is  $F_n$ .  
 (ii)  $F_{n-1}$   
 (iii) The number that start with  $k$ , for  $2 \leq k \leq n+1$ , is the number of compositions of  $(n+3) - k$  with no 1s as summands. This is  $F_{(n+3)-k-1} = F_{n-k+2}$ ,  $2 \leq k \leq n+1$ .  
 (c) If the composition starts with  $n+2$  then there is only one remaining summand - namely, 1. But here we are not allowed to use 1 as a summand, so there are no such compositions that start with  $n+2$ .

The one-summand composition ' $n+3$ ' is the only composition here that starts (and ends) with  $n+3$ .

(d) These results provide a combinatorial proof that

$$\begin{aligned} F_{n+2} &= \sum_{k=2}^{n+1} F_{n-k+2} + 1 = (F_n + F_{n-1} + \dots + F_2 + F_1) + 1, \text{ or} \\ F_{n+2} - 1 &= \sum_{i=1}^n F_i = \sum_{i=0}^n F_i, \text{ since } F_0 = 0. \end{aligned}$$

18. From  $x^2 - 1 = x$  we have  $x^2 - x - 1 = 0$ , so  $x = (1 \pm \sqrt{5})/2$ . Consequently, the points of intersection are  $((1 + \sqrt{5})/2, (1 + \sqrt{5})/2) = (\alpha, \alpha)$  and  $((1 - \sqrt{5})/2, (1 - \sqrt{5})/2) = (\beta, \beta)$ .

19. From  $1 + \frac{1}{x} = x$  we learn that  $x + 1 = x^2$ , or  $x^2 - x - 1 = 0$ . So  $x = (1 \pm \sqrt{5})/2$  and the points of intersection are  $((1 + \sqrt{5})/2, (1 + \sqrt{5})/2) = (\alpha, \alpha)$  and  $((1 - \sqrt{5})/2, (1 - \sqrt{5})/2) = (\beta, \beta)$ .

20. (a)  $\alpha^2 = [(1 + \sqrt{5})/2]^2 = (1 + 2\sqrt{5} + 5)/4 = (6 + 2\sqrt{5})/4 = (3 + \sqrt{5})/2 = [(1 + \sqrt{5})/2] + (2/2) = \alpha + 1$ .

(b) Proof: (By Mathematical Induction) For  $n = 1$ , we have  $\alpha^n = \alpha^1 = \alpha = \alpha \cdot 1 + 0 = \alpha F_1 + F_0 = \alpha F_n + F_{n-1}$ , so the result is true in this case. This establishes the basis step. Now we assume for an arbitrary (but fixed) positive integer  $k$  that  $\alpha^k = \alpha F_k + F_{k-1}$ . This is our inductive step. Considering  $n = k + 1$ , at this time, we find that

$$\begin{aligned} \alpha^{k+1} &= \alpha(\alpha^k) = \alpha[\alpha F_k + F_{k-1}] \quad (\text{by the inductive step}) \\ &= \alpha^2 F_k + \alpha F_{k-1} \\ &= (\alpha + 1)F_k + \alpha F_{k-1} \quad [\text{by part (a)}] \\ &= \alpha(F_k + F_{k-1}) + F_k \\ &= \alpha F_{k+1} + F_k. \end{aligned}$$

Since the given result is true for  $n = 1$  and the truth for  $n = k + 1$  follows from that for  $n = k$ , it follows by the Principle of Mathematical Induction that  $\alpha^n = \alpha F_n + F_{n-1}$  for all  $n \in \mathbb{Z}^+$ .

21. Proof (By the Alternative Form of the Principle of Mathematical Induction):

$$(a) \quad F_3 = 2 = (1 + \sqrt{9})/2 > (1 + \sqrt{5})/2 = \alpha = \alpha^{3-2},$$

$$F_4 = 3 = (3 + \sqrt{9})/2 > (3 + \sqrt{5})/2 = \alpha^2 = \alpha^{4-2},$$

so the result is true for these first two cases (where  $n = 3, 4$ ). This establishes the basis step. Assuming the truth of the statement for  $n = 3, 4, 5, \dots, k (\geq 4)$ , where  $k$  is a fixed (but arbitrary) integer, we continue now with  $n = k + 1$ :

$$\begin{aligned} F_{k+1} &= F_k + F_{k-1} \\ &> \alpha^{k-2} + \alpha^{(k-1)-2} \\ &= \alpha^{k-2} + \alpha^{k-3} = \alpha^{k-3}(\alpha + 1) \\ &= \alpha^{k-3} \cdot \alpha^2 = \alpha^{k-1} = \alpha^{(k+1)-2} \end{aligned}$$

Consequently,  $F_n > \alpha^{n-2}$  for all  $n \geq 3$  - by the Alternative Form of the Principle of Mathematical Induction.

$$(b) \quad F_3 = 2 = (3 + \sqrt{1})/2 < (3 + \sqrt{5})/2 = \alpha^2 = \alpha^{3-1},$$

$$F_4 = 3 = 2 + 1 < 2 + \sqrt{5} = \alpha^3 = \alpha^{4-1},$$

so this result is true for these first two cases (where  $n = 3, 4$ ). This establishes the basis step. Assuming the truth of the statement for  $n = 3, 4, 5, \dots, k (\geq 4)$ , where  $k$  is a fixed (but arbitrary) integer, we continue now with  $n = k + 1$ :

$$\begin{aligned} F_{k+1} &= F_k + F_{k-1} \\ &< \alpha^{k-1} + \alpha^{(k-1)-1} \\ &= \alpha^{k-1} + \alpha^{k-2} = \alpha^{k-2}(\alpha + 1) \\ &= \alpha^{k-2} \cdot \alpha^2 = \alpha^k = \alpha^{(k+1)-1} \end{aligned}$$

Consequently,  $F_n < \alpha^{n-1}$  for all  $n \geq 3$  - by the Alternative Form of the Principle of Mathematical Induction.

22. (a) Since  $a_{n+1} = 2a_n$  we have  $a_n = c(2^n)$ ,  $n \geq 1$ . Then  $a_1 = 2 \Rightarrow 2c = 2 \Rightarrow c = 1$ , so  $a_n = 2^n$ . Consequently, for  $n$  even, the number of palindromes of  $n$  is counted by  $a_{n/2} = 2^{n/2} = 2^{\lfloor n/2 \rfloor}$ .

(b) Here  $b_{n+1} = 2b_n$ ,  $n \geq 1$ ,  $b_1 = 1$ . So  $b_n = d(2^n)$ ,  $n \geq 1$  and  $b_1 = 1 \Rightarrow 2d = 1 \Rightarrow d = 1/2$ , so  $b_n = 2^{n-1}$ . Hence, for  $n$  odd, the number of palindromes of  $n$  is counted by  $b_{(n+1)/2} = 2^{\lfloor (n+1)/2 \rfloor - 1} = 2^{(n-1)/2} = 2^{\lfloor n/2 \rfloor}$ .

23. Here we shall use auxiliary variables. For  $n \geq 1$ , let  $a_n^{(0)}$  count the number of ternary strings of length  $n$  where there are no consecutive 1s and no consecutive 2s and the  $n$ th symbol is 0. We define  $a_n^{(1)}$  and  $a_n^{(2)}$  analogously. Then

$$\begin{aligned} a_n &= a_n^{(0)} + a_n^{(1)} + a_n^{(2)} \\ &= a_{n-1} + [a_{n-1} - a_{n-1}^{(1)}] + [a_{n-1} - a_{n-1}^{(2)}] \\ &= 2a_{n-1} + [a_{n-1} - a_{n-1}^{(1)} - a_{n-1}^{(2)}] \\ &= 2a_{n-1} + a_{n-1}^{(0)} = 2a_{n-1} + a_{n-2} \end{aligned}$$

Letting  $a_n = cr^n$ ,  $c \neq 0$ ,  $r \neq 0$ , we find that  $r^2 - 2r - 1 = 0$ , so the characteristic roots are  $1 \pm \sqrt{2}$ . Consequently,  $a_n = c_1(1 + \sqrt{2})^n + c_2(1 - \sqrt{2})^n$ . Here  $a_1 = 3$ , for the three one-symbol ternary strings 0, 1, and 2. Since we cannot use the two-symbol ternary strings 11 and 22, we have  $a_2 = 3^2 - 2 = 7$ . Extending the recurrence relation so that we can use  $n = 0$ , we have  $a_2 = 2a_1 + a_0$  so  $a_0 = a_2 - 2a_1 = 7 - 2 \cdot 3 = 1$ . With

$$\begin{aligned} 1 = a_0 &= c_1 + c_2, \text{ and} \\ 3 = a_1 &= c_1(1 + \sqrt{2}) + c_2(1 - \sqrt{2}) \\ &= (c_1 + c_2) + \sqrt{2}(c_1 - c_2), \end{aligned}$$

we now have  $1 = c_1 + c_2$  and  $\sqrt{2} = c_1 - c_2$ , so  $c_1 = (1 + \sqrt{2})/2$  and  $c_2 = (1 - \sqrt{2})/2$ . Consequently,

$$a_n = (1/2)(1 + \sqrt{2})^{n+1} + (1/2)(1 - \sqrt{2})^{n+1}, \quad n \geq 0.$$

24. Here  $a_1 = 1$ , for the case of one vertical domino, and  $a_2 = 3$  - use (i) one square tile ; or (ii) two horizontal dominoes; or (iii) two vertical dominoes. For  $n \geq 3$  consider the  $n$ th column of the chessboard. This column can be covered by

- (1) one vertical domino - this accounts for  $a_{n-1}$  of the tilings of the  $2 \times n$  chessboard;
- (2) the right squares of two horizontal dominoes placed in the four squares for the  $(n-1)$ st and  $n$ th columns of the chessboard - this accounts for  $a_{n-2}$  of the tilings; and
- (3) the right column of a square tile placed on the four squares for the  $(n-1)$ st and  $n$ th columns of the chessboard - this also accounts for  $a_{n-2}$  of the tilings.

These three cases account for all the possible tilings and no two cases have anything in common so

$$a_n = a_{n-1} + 2a_{n-2}, \quad n \geq 3, a_1 = 1, a_2 = 3.$$

Here the characteristic equation is  $x^2 - x - 2 = 0$  which gives  $x = 2$ ,  $x = -1$  as the characteristic roots. Consequently,  $a_n = c_1(-1)^n + c_2(2)^n$ ,  $n \geq 1$ . From  $1 = a_1 = c_1(-1) +$

$c_2(2)$  and  $3 = a_2 = c_1(-1)^2 + c_2(2)^2$  we learn that  $c_1 = 1/3$ ,  $c_2 = 2/3$ . So  $a_n = (1/3)[2^{n+1} + (-1)^n]$ ,  $n \geq 1$ . [The sequence 1, 3, 5, 11, 21, ..., described here, is known as the *Jacobsthal* sequence.]

25. Let  $a_n$  count the number of ways one can tile a  $2 \times n$  chessboard using these colored dominoes and square tiles. Here  $a_1 = 4$ ,  $a_2 = 4^2 + 4^2 + 5 = 37$ , and, for  $n \geq 3$ ,  $a_n = 4a_{n-1} + 16a_{n-2} + 5a_{n-3} = 4a_{n-1} + 21a_{n-2}$ . The characteristic equation is  $x^2 - 4x - 21 = 0$  and this gives  $x = 7$ ,  $x = -3$  as the characteristic roots. Consequently,  $a_n = c_1(7)^n + c_2(-3)^n$ ,  $n \geq 1$ .

Here  $a_0 = (1/21)(a_2 - 4a_1) = 1$  can be introduced to simplify the calculations for  $c_1, c_2$ . From  $1 = a_0 = c_1 + c_2$  and  $4 = 7c_1 - 3c_2$  we learn that  $c_1 = 7/10$ ,  $c_2 = 3/10$ , so  $a_n = (7/10)(7)^n + (3/10)(-3)^n$ ,  $n \geq 0$ .

When  $n = 10$  we find that the  $2 \times 10$  chessboard can be tiled in  $(7/10)(7)^{10} + (3/10)(-3)^{10} = 197,750,389$  ways.

26. Here  $a_1 = 1$  (for the string 0) and  $a_2 = 3$  (for the strings 00, 01 and 11). For  $n \geq 3$ , there are three cases to consider:

- (1) The  $n$ th symbol is 0: There are  $a_{n-1}$  such strings.
- (2) The  $(n-1)$ st and  $n$ th symbols are 0, 1, respectively: There are  $a_{n-2}$  such strings.
- (3) The  $(n-1)$ st and  $n$ th symbols are both 1: Here there are also  $a_{n-2}$  strings.

These three cases include all possibilities and no two cases have anything in common. Consequently,

$$a_n = a_{n-1} + 2a_{n-2}, \quad a_1 = 1, \quad a_2 = 3.$$

The characteristic equation,  $r^2 - r - 2 = 0$ , yields the characteristic roots 2 and  $-1$ , so  $a_n = c_1(2)^n + c_2(-1)^n$ . From  $1 = a_1 = 2c_1 - c_2$  and  $3 = a_2 = 4c_1 + c_2$ , we learn that  $c_1 = 2/3$  and  $c_2 = 1/3$ . So

$$a_n = (2/3)(2)^n + (1/3)(-1)^n, \quad n \geq 1.$$

[So here we find another occurrence of the Jacobsthal numbers.]

27. There is  $a_1 = 1$  string of length 1 (namely, 0) in  $A^*$ , and  $a_2 = 2$  strings of length 2 (namely, 00 and 01) and  $a_3 = 5$  strings of length 3 (namely, 000, 001, 010, 011 and 111). For  $n \geq 4$  we consider the entry from  $A$  at the (right) end of the string.

- (1) 0: there are  $a_{n-1}$  strings.
- (2) 01: there are  $a_{n-2}$  strings.
- (3) 011, 111: there are  $a_{n-3}$  strings in each of these two cases.

Consequently,

$$a_n = a_{n-1} + a_{n-2} + 2a_{n-3}, \quad n \geq 4, \quad a_1 = 1, \quad a_2 = 2, \quad a_3 = 5.$$

From the characteristic equation  $r^3 - r^2 - r - 2 = 0$ , we find that  $(r-2)(r^2+r+1) = 0$  and the characteristic roots are 2 and  $(-1 \pm i\sqrt{3})/2$ . Since  $(-1+i\sqrt{3})/2 = \cos 120^\circ + i \sin 120^\circ =$

$\cos(\frac{2\pi}{3}) + i \sin(\frac{2\pi}{3})$ , we have

$$a_n = c_1(2)^n + c_2 \cos \frac{2n\pi}{3} + c_3 \sin \frac{2n\pi}{3}, \quad n \geq 1.$$

From

$$1 = a_1 = 2c_1 - c_2/2 + c_3(\sqrt{3}/2)$$

$$2 = a_2 = 4c_1 - c_2/2 - c_3(\sqrt{3}/2)$$

$$5 = a_3 = 8c_1 + c_2,$$

we learn that  $c_1 = 4/7$ ,  $c_2 = 3/7$ , and  $c_3 = \sqrt{3}/21$ , so

$$a_n = (4/7)(2)^n + (3/7)\cos(2n\pi/3) + (\sqrt{3}/21)\sin(2n\pi/3), \quad n \geq 1.$$

[Note that  $a_n$  also counts the number of ways one can tile a  $1 \times n$  chessboard using  $1 \times 1$  square tiles of one color,  $1 \times 2$  rectangular tiles of one color, and  $1 \times 3$  rectangular tiles that come in *two* colors.]

28. Here  $a_1 = 1$  (for 0),  $a_2 = 2$  (for 00,01),  $a_3 = 4$  (for 000, 001, 010, 011),  $a_4 = 9$  (for 0000, 0001, 0010, 0100, 0011, 0110, 0111, 1111, 0101), and for  $n \geq 5$

$$a_n = a_{n-1} + a_{n-2} + a_{n-3} + 2a_{n-4}.$$

The characteristic equation  $r^4 - r^3 - r^2 - r - 2 = 0$  tells us that  $(r-2)(r+1)(r^2+1) = 0$ , so the characteristic roots are 2,  $-1$ ,  $\pm i$ . Consequently,

$$a_n = c_1(2)^n + c_2(-1)^n + c_3 \cos(n\pi/2) + c_4 \sin(n\pi/2), \quad n \geq 1.$$

From

$$1 = a_1 = 2c_1 - c_2 + c_4$$

$$2 = a_2 = 4c_1 + c_2 - c_3$$

$$4 = a_3 = 8c_1 - c_2 - c_4$$

$$9 = a_4 = 16c_1 + c_2 + c_3$$

we learn that  $c_1 = 8/15$ ,  $c_2 = 1/6$ ,  $c_3 = 3/10$ , and  $c_4 = 1/10$ , so  $a_n = (8/15)(2)^n + (1/6)(-1)^n + (3/10)\cos(n\pi/2) + (1/10)\sin(n\pi/2)$ ,  $n \geq 1$ .

[Note that  $a_n$  also counts the number of ways one can tile a  $1 \times n$  chessboard using red  $1 \times 1$  square tiles, white  $1 \times 2$  rectangular tiles, blue  $1 \times 3$  rectangular tiles, black  $1 \times 4$  rectangular tiles and green  $1 \times 4$  rectangular tiles.]

29.  $x_{n+2} - x_{n+1} = 2(x_{n+1} - x_n)$ ,  $n \geq 0$ ,  $x_0 = 1$ , and  $x_1 = 5$ .

$$x_{n+2} - 3x_{n+1} + 2x_n = 0$$

For  $n \geq 0$ , let  $x_n = cr^n$ , where  $c, r \neq 0$ . Then we get the characteristic equation  $r^2 - 3r + 2 = 0 = (r-2)(r-1)$ , so  $x_n = A(2^n) + B(1^n) = A(2^n) + B$ .

$$x_0 = 1 = A + B$$

$$x_1 = 5 = 2A + B$$

Hence  $4 = A$ ,  $B = -3$ , and  $x_n = 4(2^n) - 3 = 2^{n+2} - 3$ , for  $n \geq 0$ .

30. Expanding by row 1,  $D_n = 2D_{n-1} - D$ , where  $D$  is an  $(n-1)$  by  $(n-1)$  determinant whose value, upon expansion by its first column, is  $D_{n-2}$ . Hence  $D_n = 2D_{n-1} - D_{n-2}$ . This recurrence relation determines the characteristic roots  $r = 1, 1$  so the value of  $D_n = A(1)^n + Bn(1)^n = A + Bn$ .

$$D_1 = |2| = 2 \quad D_2 = \begin{vmatrix} 2 & 1 \\ 1 & 2 \end{vmatrix} = 4 - 1 = 3$$

$$2 = D_1 = A + B; 3 = D_2 = A + 2B \implies B = A = 1 \text{ and } D_n = 1 + n, n \geq 1.$$

31. Let  $b_n = a_n^2$ ,  $b_0 = 16$ ,  $b_1 = 169$ .

This yields the linear relation  $b_{n+2} - 5b_{n+1} + 4b_n = 0$  with characteristic roots  $r = 4, 1$ , so  $b_n = A(1)^n + B(4)^n$ .

$$b_0 = 16, b_1 = 169 \implies A = -35, B = 51 \text{ and } b_n = 51(4)^n - 35. \text{ Hence } a_n = \sqrt{51(4)^n - 35}, n \geq 0.$$

32.  $a_n = c_1 + c_2(7)^n$ ,  $n \geq 0$ , is the solution of  $a_{n+2} + ba_{n+1} + ca_n = 0$ , so  $r^2 + br + c = 0$  is the characteristic equation and  $(r-1)(r-7) = (r^2 - 8r + 7) = r^2 + br + c$ . Consequently,  $b = -8$  and  $c = 7$ .

33. Since  $\gcd(F_1, F_0) = 1 = \gcd(F_2, F_1)$ , consider  $n \geq 2$ . Then

$$F_3 = F_2 + F_1 (= 1)$$

$$F_4 = F_3 + F_2$$

$$F_5 = F_4 + F_3$$

⋮

$$F_{n+1} = F_n + F_{n-1}.$$

Reversing the order of these equations we have the steps in the Euclidean Algorithm for computing the gcd of  $F_{n+1}$  and  $F_n$ , for  $n \geq 2$ . Since the last nonzero remainder is  $F_1 = 1$ , it follows that  $\gcd(F_{n+1}, F_n) = 1$  for all  $n \geq 2$ .

- 34.

Program Fibonacci (input, output);

Var

    number: integer; {the input}

    i: integer; {i is a counter}

    current: integer;

    Fibonacci: array [1..100] of integer;

Begin

    Write ('This program is designed to determine if ');

    Write ('a given nonnegative integer is a ');

    Writeln ('Fibonacci number.');

    Writeln ('What nonnegative integer n do you wish to test?');

    Write ('n= ');

```

Readln (number);
If number < 0 then
    Writeln ('Your input is not appropriate.')
Else if number = 0 then
    Writeln ('Your number is the 0-th Fibonacci number.')
Else if number = 1 then
    Writeln ('Your number is the 1-st Fibonacci number.')
Else {number ≥ 2}
    Begin
        Fibonacci [1] := 1;
        Fibonacci [2] := 1;
        current := 1;
        i := 3;
        While number > current do
            Begin
                Fibonacci [i] := Fibonacci [i-1] + Fibonacci [i-2];
                current := Fibonacci [i];
                If number < current then
                    Writeln ('Your number is not a Fibonacci number.')
                Else if number = current then
                    Writeln ('Your number is the ', i:0, '-th Fibonacci number.')
                Else i := i + 1 {number > count}
            End {while}
        End {else}
    End.

```

### Section 10.3

1. (a)  $a_{n+1} - a_n = 2n + 3, n \geq 0, a_0 = 1$

$$a_1 = a_0 + 0 + 3$$

$$a_2 = a_1 + 2 + 3 = a_0 + 2 + 2(3)$$

$$a_3 = a_2 + 2(2) + 3 = a_0 + 2 + 2(2) + 3(3)$$

$$a_4 = a_3 + 2(3) + 3 = a_0 + [2 + 2(2) + 2(3)] + 4(3)$$

⋮

$$a_n = a_0 + 2[1 + 2 + 3 + \dots + (n-1)] + n(3) = 1 + 2[n(n-1)/2] + 3n = 1 + n(n-1) + 3n = n^2 + 2n + 1 = (n+1)^2, n \geq 0.$$

(b)  $a_n = 3 + n(n-1)^2, n \geq 0$

(c)  $a_{n+1} - 2a_n = 5, n \geq 0, a_0 = 1$

$$a_1 = 2a_0 + 5 = 2 + 5$$

$$a_2 = 2a_1 + 5 = 2^2 + 2 \cdot 5 + 5$$

$$a_3 = 2a_2 + 5 = 2^3 + (2^2 + 2 + 1)5$$

$$a_n = 2^n + 5(1 + 2 + 2^2 + \dots + 2^{n-1}) = 2^n + 5(2^n - 1) = 6(2^n) - 5, n \geq 0.$$

$$(d) a_n = 2^n + n(2^{n-1}), n \geq 0.$$

$$2. a_n = \sum_{i=0}^n i^2.$$

$$a_{n+1} = a_n + (n+1)^2, n \geq 0, a_0 = 0.$$

$$a_{n+1} - a_n = (n+1)^2 = n^2 + 2n + 1$$

$$a_n^{(h)} = A, a_n^{(p)} = Bn + Cn^2 + Dn^3$$

$$B(n+1) + C(n+1)^2 + D(n+1)^3 = Bn + Cn^2 + Dn^3 + n^2 + 2n + 1 \implies$$

$$Bn + B + Cn^2 + 2Cn + C + Dn^3 + 3Dn^2 + 3Dn + D = Bn + Cn^2 + Dn^3 + n^2 + 2n + 1.$$

By comparing coefficients on like powers of  $n$  we find that  $C + 3D = C + 1$ , so  $D = 1/3$ .

Also  $B + 2C + 3D = B + 2$ , so  $C = 1/2$ . Finally,  $B + C + D = 1 \implies B = 1/6$ .

So  $a_n = A + (1/6)n + (1/2)n^2 + (1/3)n^3$ . With  $a_0 = 0$ , it follows that  $A = 0$  and

$$a_n = (1/6)(n)[1 + 3n + 2n^2] = (1/6)(n)(n+1)(2n+1), n \geq 0.$$

3. (a) Let  $a_n$  = the number of regions determined by the  $n$  lines under the conditions specified. When the  $n$ -th line is drawn there are  $n - 1$  points of intersection and  $n$  segments are formed on the line. Each of these segments divides a region into two regions and this increases the number of previously existing regions, namely  $a_{n-1}$ , by  $n$ .

$$a_n = a_{n-1} + n, n \geq 1, a_0 = 1.$$

$$a_n^{(h)} = A, a_n^{(p)} = Bn + Cn^2$$

$$Bn + Cn^2 = B(n-1) + C(n-1)^2 + n$$

$$Bn + Cn^2 - Bn + B - Cn^2 + 2Cn - C = n.$$

By comparing the coefficients on like powers of  $n$  we have  $B = C = 1/2$  and  $a_n = A + (1/2)n + (1/2)n^2$ .

$$1 = a_0 = A \text{ so } a_n = 1 + (1/2)(n)(n+1), n \geq 0.$$

(b) Let  $b_n$  = the number of infinite regions that result for  $n$  such lines. When the  $n$ th line is drawn it is divided into  $n$  segments. The first and  $n$ th segments each create a new infinite region. Hence  $b_n = b_{n-1} + 2, n \geq 2, b_1 = 2$ . The solution of this recurrence relation is  $b_n = 2n, n \geq 1, b_0 = 1$ .

4. Let  $p_n$  be the value of the account  $n$  months after January 1 of the year the account is started.

$$p_0 = 1000$$

$$p_1 = 1000 + (.005)(1000) + 200 = (1.005)p_0 + 200$$

$$p_{n+1} = (1.005)p_n + 200, 0 \leq n \leq 46$$

$$p_{48} = (1.005)p_{47}$$

$$p_{n+1} - 1.005p_n = 200, 0 \leq n \leq 46$$

$$p_n^{(h)} = A(1.005)^n, p_n^{(p)} = C$$

$$C - 1.005C = 200 \implies C = -40,000$$

$$p_0 = A(1.005)^0 - 40,000 = 1000, \text{ so } A = 41,000$$

$$p_n = (41,000)(1.005)^n - 40,000$$

$$p_{47} = (41,000)(1.005)^{47} - 40,000 = \$11,830.90$$

$$p_{48} = (1.005)p_{47} = \$11,890.05$$

5. (a)  $a_{n+2} + 3a_{n+1} + 2a_n = 3^n$ ,  $n \geq 0$ ,  $a_0 = 0$ ,  $a_1 = 1$ .  
 With  $a_n = cr^n$ ,  $c, r \neq 0$ , the characteristic equation  $r^2 + 3r + 2 = 0 = (r + 2)(r + 1)$  yields the characteristic roots  $r = -1, -2$ .  
 Hence  $a_n^{(h)} = A(-1)^n + B(-2)^n$ , while  $a_n^{(p)} = C(3)^n$ .  
 $C(3)^{n+2} + 3C(3)^{n+1} + 2C(3)^n = 3^n \implies 9C + 9C + 2C = 1 \implies C = 1/20$ .  
 $a_n = A(-1)^n + B(-2)^n + (1/20)(3)^n$   
 $0 = a_0 = A + B + (1/20)$   
 $1 = a_1 = -A - 2B + (3/20)$   
 Hence  $1 = a_0 + a_1 = -B + (4/20)$  and  $B = -4/5$ . Then  $A = -B - (1/20) = 3/4$ .  
 $a_n = (3/4)(-1)^n + (-4/5)(-2)^n + (1/20)(3)^n$ ,  $n \geq 0$
- (b)  $a_n = (2/9)(-2)^n - (5/6)(n)(-2)^n + (7/9)$ ,  $n \geq 0$
6.  $a_{n+2} - 6a_{n+1} + 9a_n = 3(2)^n + 7(3)^n$ ,  $n \geq 0$ ,  $a_0 = 1$ ,  $a_1 = 4$ .  
 $a_n^{(h)} = A(3)^n + Bn(3)^n$        $a_n^{(p)} = C(2)^n + Dn^2(3)^n$ .  
 Substituting  $a_n^{(p)}$  into the given recurrence relation, by comparison of coefficients we find that  $C = 3$ ,  $D = 7/18$ .  
 $a_n = A(3)^n + Bn(3)^n + 3(2)^n + (7/18)n^2(3)^n$   
 $1 = a_0, 4 = a_1 \implies A = -1, B = 17/18$ , so  
 $a_n = (-2)(3)^n + (17/18)n(3)^n + (7/18)n^2(3)^n + 3(2)^n$ ,  $n \geq 0$ .
7. Here the characteristic equation is  $r^3 - 3r^2 + 3r - 1 = 0 = (r - 1)^3$ , so  $r = 1, 1, 1$  and  $a_n^{(h)} = A + Bn + Cn^2$ ,  $a_n^{(p)} = Dn^3 + En^4$ .  
 $D(n+3)^3 + E(n+3)^4 - 3D(n+2)^3 - 3E(n+2)^4 + 3D(n+1)^3 + 3E(n+1)^4 - Dn^3 - En^4 = 3 + 5n \implies D = -3/4, E = 5/24$ .  
 $a_n = A + Bn + Cn^2 - (3/4)n^3 + (5/24)n^4$ ,  $n \geq 0$ .
8.  $a_{n+1} = 3a_n + 3^n$ ,  $a_0 = 1$ ,  $a_1 = 4$ . The term  $3^n$  accounts for the sequences of length  $n$  that end in 3;  $3a_n$  accounts for those sequences of length  $n$  that end in 0, 1, or 2.  
 $a_n^{(h)} = A3^n$ ,  $a_n^{(p)} = Bn3^n$   
 $B(n+1)3^{n+1} = 3(Bn3^n) + 3^n \implies 3B(n+1) = 3Bn + 1 \implies 3B = 1 \implies B = 1/3$   
 $a_n = A \cdot 3^n + n \cdot 3^{n-1}$   
 $1 = a_0 = A$ , so  $a_n = 3^n + n3^{n-1}$ ,  $n \geq 0$ .
9. From Example 10.29,  $P = (Si)[1 - (1+i)^{-T}]^{-1}$ , where  $P$  is the payment,  $S$  is the loan (\$2500),  $T$  is the number of payments (24) and  $i$  is the interest rate per month (1%).
- $$P = (2500)(0.01)[1 - (1.01)^{-24}]^{-1} = \$117.68.$$

10.  $a_{n+2} + b_1 a_{n+1} + b_2 a_n = b_3 n + b_4$   
 $a_n = c_1 2^n + c_2 3^n + n - 7$   
 $r^2 + b_1 r + b_2 = (r - 2)(r - 3) = r^2 - 5r + 6 \implies b_1 = -5, b_2 = 6$

$$a_n^{(p)} = n - 7$$

$$[(n+2) - 7] - 5[(n+1) - 7] + 6(n-7) = b_3n + b_4 \implies b_3 = 2, b_4 = -17.$$

11. (a) Let  $a_n^2 = b_n, n \geq 0$

$$b_{n+2} - 5b_{n+1} + 6b_n = 7n$$

$$b_n^{(h)} = A(3^n) + B(2^n), b_n^{(p)} = Cn + D$$

$$C(n+2) + D - 5[C(n+1) + D] + 6(Cn + D) = 7n \implies C = 7/2, D = 21/4$$

$$b_n = A(3^n) + B(2^n) + (7n/2) + (21/4)$$

$$b_0 = a_0^2 = 1, b_1 = a_1^2 = 1$$

$$1 = b_0 = A + B + 21/4$$

$$1 = b_1 = 3A + 2B + 7/2 + 21/4$$

$$3A + 2B = -31/3$$

$$2A + 2B = -34/4$$

$$A = 3/4, B = -5$$

$$a_n = [(3/4)(3^n) - 5(2^n) + (7n/2) + (21/4)]^{1/2}, n \geq 0$$

(b)  $a_n^2 - 2a_{n-1} = 0, n \geq 1, a_0 = 2$

$$a_n^2 = 2a_{n-1}$$

$$\log_2 a_n^2 = \log_2(2a_{n-1}) = \log_2 2 + \log_2 a_{n-1}$$

$$2 \log_2 a_n = 1 + \log_2 a_{n-1}$$

$$\text{Let } b_n = \log_2 a_n.$$

The solution of the recurrence relation  $2b_n = 1 + b_{n-1}$  is  $b_n = A(1/2)^n + 1$ .

$$b_0 = \log_2 a_0 = \log_2 2 = 1, \text{ so } 1 = b_0 = A + 1 \text{ and } A = 0.$$

Consequently,  $b_n = 1, n \geq 0$ , and  $a_n = 2, n \geq 0$ .

12. Consider the  $n$ th symbol for the strings counted by  $a_n$ . For  $n \geq 2$ , we consider two cases:

(1) If this symbol is 0, 2, or 3, then the preceding  $n-1$  symbols provide a string of length  $n-1$  counted by  $a_{n-1}$ .

(2) If this symbol is 1, then the preceding  $n-1$  symbols contain an even number of 1s - there are  $4^{n-1} - a_{n-1}$  such strings of length  $n-1$ .

Since these two cases are exhaustive and have nothing in common we have

$$a_n = 3a_{n-1} + (4^{n-1} - a_{n-1}) = 2a_{n-1} + 4^{n-1}, \quad n \geq 2.$$

Here  $a_n = a_n^{(h)} + a_n^{(p)}$ , where  $a_n^{(p)} = A(4^{n-1})$  and  $a_n^{(h)} = c(2^n)$ .

Substituting  $a_n^{(p)}$  into the above recurrence relation for  $a_n$  we find that  $A(4^{n-1}) = 2A(4^{n-2}) + 4^{n-1}$ , so  $4A = 2A + 4$  and  $A = 2$ .

There is only one string of length 1 where there is an odd number of 1s - namely, the string 1. So

$$a_1 = 1 = c(2) + 2(4^0), \quad \text{and } c = -1/2.$$

Consequently,  $a_n = (-1/2)(2^n) + 2(4^{n-1}), n \geq 1$ .

We can check this result by using an exponential generating function. Here  $a_n$  is the coefficient of  $x^n/n!$  in  $e^x \left( \frac{e^x - e^{-x}}{2} \right) (e^x)^2 = \frac{1}{2} e^{4x} - \frac{1}{2} e^{2x}$ . Hence  $a_n = (\frac{1}{2})(4^n) - \frac{1}{2}(2^n), n \geq 1$ .

13. (a) Consider the  $2^n$  binary strings of length  $n$ . Half of these strings ( $2^{n-1}$ ) end in 0 and the other half ( $2^{n-1}$ ) in 1. For the  $2^{n-1}$  binary strings of length  $(n-1)$ , there are  $t_{n-1}$  runs. When we append 0 to each of these strings we get  $t_{n-1} + (\frac{1}{2})(2^{n-1})$  runs, where the additional  $(\frac{1}{2})(2^{n-1})$  runs arise when we append 0 to the  $(\frac{1}{2})(2^{n-1})$  strings of length  $(n-1)$  that end in 1. Upon appending 1 to each of the  $2^{n-1}$  binary strings of length  $n-1$ , we get the remaining  $t_{n-1} + (\frac{1}{2})(2^{n-1})$  runs. Consequently we find that

$$t_n = 2t_{n-1} + 2^{n-1}, \quad n \geq 2, \quad t_1 = 2.$$

Here  $t_n^{(h)} = c(2^n)$ , so  $t_n^{(p)} = An(2^n)$ . Substituting  $t_n^{(p)}$  into the recurrence relation we have

$$\begin{aligned} An(2^n) &= 2A(n-1)2^{n-1} + 2^{n-1} \\ &= An(2^n) - A(2^n) + 2^{n-1} \end{aligned}$$

By comparison of coefficients for  $2^n$  and  $n2^n$  we learn that  $A = \frac{1}{2}$ . Consequently,  $t_n = t_n^{(h)} + t_n^{(p)} = c(2^n) + n(2^{n-1})$ , and  $2 = t_1 = c(2) + 1 \Rightarrow c = \frac{1}{2}$ , so  $t_n = (\frac{1}{2})(2^n) + n(2^{n-1}) = (n+1)(2^{n-1})$ ,  $n \geq 1$ .

(b) Here there are  $4^n$  quaternary strings of length  $n$  and  $4^{n-1}$  of these end in each of the one symbol suffices 0, 1, 2, and 3. In this case

$$t_n = 4[t_{n-1} + (\frac{3}{4})4^{n-1}] = 4t_{n-1} + 3(4^{n-1}), \quad n \geq 2, \quad t_1 = 4.$$

Comparable to the solution for part (a), here  $t_n^{(h)} = c(4^n)$  and  $t_n^{(p)} = An(4^n)$ . So  $An4^n = 4A(n-1)4^{n-1} + (3)(4^{n-1}) = An4^n - A(4^n) + (\frac{3}{4})4^n$ , and  $A = \frac{3}{4}$ . Consequently,  $t_n = c(4^n) + (\frac{3}{4})n4^n$  and  $4 = t_1 = 4c + (\frac{3}{4})(4) \Rightarrow c = \frac{1}{4}$ , so  $t_n = (\frac{1}{4})4^n + (\frac{3}{4})n4^n = 4^{n-1}(1+3n)$ ,  $n \geq 1$ .

(c) For an alphabet  $\Sigma$ , where  $|\Sigma| = r \geq 1$ , there are  $r^n$  strings of length  $n$  and these  $r^n$  strings determine a total of  $r^{n-1}[1 + (r-1)n]$  runs. [Note: This formula includes the case where  $r = 1$ .]

14. (a)  $s_{n+1} = s_n + t_{n+1} = s_n + (n+1)(n+2)/2$

$$s_{n+1} - s_n = (1/2)(n^2 + 3n + 2)$$

$$s_n = s_n^{(h)} + s_n^{(p)}$$

$$s_{n+1}^{(h)} - s_n^{(h)} = 0, \text{ so } s_n^{(h)} = A(1^n) = A$$

$$s_n^{(p)} = n(Bn^2 + Cn + D) = Bn^3 + Cn^2 + Dn$$

$$B(n+1)^3 + C(n+1)^2 + D(n+1) - Bn^3 - Cn^2 - Dn = (1/2)(n^2 + 3n + 2) \implies$$

$$B = 1/6, \quad C = 1/2, \quad D = 1/3$$

$$s_n = A + (1/6)n^3 + (1/2)n^2 + (1/3)n$$

$$\text{Since } s_1 = t_1 = 1, \quad 1 = A + (1/6) + (1/2) + (1/3) \implies A = 0, \text{ and } s_n = (1/6)(n)(n+1)(n+2).$$

- (b) (i)  $s_{10,000,000}$  atoms.

(ii)  $s_{99,999} - s_{10,000} \doteq 1.665 \times 10^{14}$  atoms.

15.

Program Towers\_of\_Hanoi (input, output);

Var

number: integer; {number = number of disks}

Procedure Move\_The\_Disks (n: integer; start, inter, finish; char);

{This procedure will move n disks from the *start* peg to the *finish* peg using inter as the *intermediary* peg.}

Begin

If n=1 then

Writeln ('Move disk from ', start, ' to ', finish, '.')

Else

Begin

Move\_The\_Disks (n-1, start, finish, inter);

Move\_The\_Disks (1, start, ' ', finish);

Move\_The\_Disks (n-1, inter, start, finish)

End {else}

End; {procedure}

Begin {main program}

Write ('How many disks are there? ');

Readln (number);

If number < 1 then

Writeln ('Your input is not appropriate.')

Else

Move\_The\_Disks (number, '1','2','3')

End.

## Section 10.4

1. (a)  $a_{n+1} - a_n = 3^n \quad n \geq 0, a_0 = 1$

Let  $f(x) = \sum_{n=0}^{\infty} a_n x^n$ .

$$\sum_{n=0}^{\infty} a_{n+1} x^{n+1} - \sum_{n=0}^{\infty} a_n x^{n+1} = \sum_{n=0}^{\infty} 3^n x^{n+1}$$

$$[f(x) - a_0] - x f(x) = x \sum_{n=0}^{\infty} (3x)^n = x/(1 - 3x)$$

$$f(x) - 1 - x f(x) = x/(1 - 3x)$$

$$f(x) = 1/(1 - x) + x/((1 - x)(1 - 3x)) = 1/(1 - x) + (-1/2)/(1 - x) + (1/2)/(1 - 3x) = (1/2)/(1 - x) + (1/2)(1 - 3x), \text{ and } a_n = (1/2)[1 + 3^n], n \geq 0.$$

- (b)  $a_n = 1 + [n(n - 1)(2n - 1)/6], n \geq 0.$

- (c)  $a_{n+2} - 3a_{n+1} + 2a_n = 0, n \geq 0, a_0 = 1, a_1 = 6$

$$\sum_{n=0}^{\infty} a_{n+2} x^{n+2} - 3 \sum_{n=0}^{\infty} a_{n+1} x^{n+2} + 2 \sum_{n=0}^{\infty} a_n x^{n+2} = 0$$

$$\sum_{n=0}^{\infty} a_{n+2}x^{n+2} - 3x \sum_{n=0}^{\infty} a_{n+1}x^{n+1} + 2x^2 \sum_{n=0}^{\infty} a_n x^n = 0$$

Let  $f(x) = \sum_{n=0}^{\infty} a_n x^n$ . Then

$(f(x) - 1 - 6x) - 3x(f(x) - 1) + 2x^2 f(x) = 0$ , and  $f(x)(1 - 3x + 2x^2) = 1 + 6x - 3x = 1 + 3x$ .  
Consequently,

$$f(x) = \frac{1 + 3x}{(1 - 2x)(1 - x)} = \frac{5}{(1 - 2x)} + \frac{(-4)}{(1 - x)} = 5 \sum_{n=0}^{\infty} (2x)^n - 4 \sum_{n=0}^{\infty} x^n,$$

and  $a_n = 5(2^n) - 4$ ,  $n \geq 0$ .

(d)  $a_{n+2} - 2a_{n+1} + a_n = 2^n$ ,  $n \geq 0$ ,  $a_0 = 1$ ,  $a_1 = 2$

$$\sum_{n=0}^{\infty} a_{n+2}x^{n+2} - 2 \sum_{n=0}^{\infty} a_{n+1}x^{n+2} + \sum_{n=0}^{\infty} a_n x^{n+2} = \sum_{n=0}^{\infty} 2^n x^{n+2}$$

Let  $f(x) = \sum_{n=0}^{\infty} a_n x^n$ . Then

$$[f(x) - a_0 - a_1x] - 2x[f(x) - a_0] + x^2 f(x) = x^2 \sum_{n=0}^{\infty} (2x)^n$$

$$f(x) - 1 - 2x - 2xf(x) + 2x + x^2 f(x) = x^2/(1 - 2x)$$

$$(x^2 - 2x + 1)f(x) = 1 + x^2/(1 - 2x) \implies f(x) = 1/(1 - x)^2 +$$

$$x^2/((1 - 2x)(1 - x)^2) = (1 - 2x + x^2)/((1 - x)^2(1 - 2x)) = 1/(1 - 2x) = 1 + 2x + (2x)^2 + \dots,$$

so  $a_n = 2^n$ ,  $n \geq 0$ .

2.  $a(n, r) = a(n - 1, r - 1) + a(n - 1, r)$ ,  $r \geq 1$ .

$$\sum_{r=1}^{\infty} a(n, r)x^r = \sum_{r=1}^{\infty} a(n - 1, r - 1)x^r + \sum_{r=1}^{\infty} a(n - 1, r)x^r$$

$$a(n, 0) = 1, n \geq 0; a(0, r) = 0, r > 0.$$

$$\text{Let } f_n = \sum_{r=0}^{\infty} a(n, r)x^r.$$

$$f_n - a(n, 0) = x f_{n-1} + f_{n-1} - a(n - 1, 0)$$

$$f_n = (1 + x)f_{n-1} \text{ and } f_n = (1 + x)^n f_0$$

$$f_0 = \sum_{r=0}^{\infty} a(0, r)x^r = a(0, 0) + a(0, 1)x + a(0, 2)x^2 + \dots = a(0, 0) = 1, \text{ so } f_n = (1 + x)^n$$

generates  $a(n, r)$ ,  $r \geq 0$ .

3. (a)  $a_{n+1} = -2a_n - 4b_n$

$$b_{n+1} = 4a_n + 6b_n$$

$$n \geq 0, a_0 = 1, b_0 = 0.$$

Let  $f(x) = \sum_{n=0}^{\infty} a_n x^n$ ,  $g(x) = \sum_{n=0}^{\infty} b_n x^n$ .

$$\sum_{n=0}^{\infty} a_{n+1}x^{n+1} = -2 \sum_{n=0}^{\infty} a_n x^{n+1} - 4 \sum_{n=0}^{\infty} b_n x^{n+1}$$

$$\sum_{n=0}^{\infty} b_{n+1}x^{n+1} = 4 \sum_{n=0}^{\infty} a_n x^{n+1} + 6 \sum_{n=0}^{\infty} b_n x^{n+1}$$

$$f(x) - a_0 = -2xf(x) - 4xg(x)$$

$$g(x) - b_0 = 4xf(x) + 6xg(x)$$

$$f(x)(1 + 2x) + 4xg(x) = 1$$

$$f(x)(-4x) + (1 - 6x)g(x) = 0$$

$$f(x) = \frac{\begin{vmatrix} 1 & 4 \\ 0 & (1-6x) \end{vmatrix}}{\begin{vmatrix} (1+2x) & 4x \\ -4x & (1-6x) \end{vmatrix}} = (1-6x)/(1-2x)^2 =$$

$$(1-6x)(1-2x)^{-2} = (1-6x)\left[\binom{-2}{0} + \binom{-2}{1}(-2x) + \binom{-2}{2}(-2x)^2 + \dots\right]$$

$$a_n = \binom{-2}{n}(-2)^n - 6\binom{-2}{n-1}(-2)^{n-1} = 2^n(1-2n), \quad n \geq 0$$

$$f(x)(-4x) + (1-6x)g(x) = 0 \implies g(x) = (4x)f(x)(1-6x)^{-1} \implies g(x) = 4x(1-2x)^{-2} \text{ and } b_n = 4\binom{-2}{n-1}(-2)^{n-1} = n(2^{n+1}), \quad n \geq 0.$$

$$(b) \quad a_n = (-3/4) + (1/2)(n+1) + (1/4)(3^n), \quad n \geq 0$$

$$b_n = (3/4) + (1/2)(n+1) - (1/4)(3^n), \quad n \geq 0$$

### Section 10.5

$$1. \quad b_4 = b_0b_3 + b_1b_2 + b_2b_1 + b_3b_0 = 2(5+2) = 14$$

$$b_n = \left\{ \frac{(2n)!}{(n+1)!(n!)} \right\}, \quad b_4 = 8!/(5!4!) = 14$$

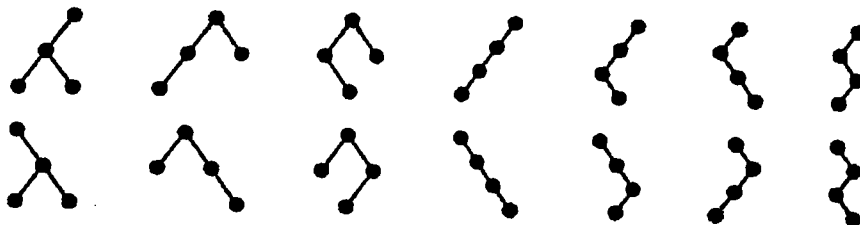

$$2. \quad (1/2)(1/(2n+1))\binom{2n+2}{n+1} = (1/2)(1/(2n+1))\left[\frac{(2n+2)(2n+1)(2n)!}{(n+1)!(n+1)!}\right]$$

$$= (1/2)\left[\frac{(2n+2)}{(n+1)^2}\right]\left[\frac{(2n)!}{(n!)^2}\right] = (1/(n+1))\binom{2n}{n}$$

$$3. \quad \binom{2n-1}{n} - \binom{2n-1}{n-2} = \left[\frac{(2n-1)!}{n!(n-1)!}\right] - \left[\frac{(2n-1)!}{(n-2)!(n+1)!}\right] =$$

$$\left[\frac{(2n-1)!(n+1)}{(n+1)!(n-1)!}\right] - \left[\frac{(2n-1)!(n-1)}{(n-1)!(n+1)!}\right] = \left[\frac{(2n-1)!}{(n+1)!(n-1)!}\right] [(n+1) - (n-1)] =$$

$$\frac{(2n-1)!(2)}{(n+1)!(n-1)!} = \frac{(2n-1)!(2n)}{(n+1)!n!} = \frac{(2n)!}{(n+1)(n!)(n!)} = \frac{1}{(n+1)} \binom{2n}{n}$$

4. (a) No (b) Yes (c) No (d) Yes

5.

(a)  $(1/9) \binom{16}{8}$  (b)  $[(1/4) \binom{6}{3}]^2$   
(c)  $[(1/6) \binom{10}{5}] [(1/3) \binom{4}{2}]$  (d)  $(1/6) \binom{10}{5}$

6. (a)  $t_{n+1}$ : For  $n \geq 2$ , let  $v_1, v_2, \dots, v_{n+1}$  be the vertices of a convex  $(n+1)$ -gon. In each partition of this polygon into triangles, with no diagonals intersecting, the side  $v_1 v_{n+1}$  is part of one of these triangles. The triangle is given by  $v_1 v_i v_{n+1}$ ,  $2 \leq i \leq n$ . For each  $2 \leq i \leq n$ , once the triangle  $v_1 v_i v_{n+1}$  is drawn, we consider the resulting polygon on  $v_1, v_2, \dots, v_i$  and the other polygon on  $v_i, v_{i+1}, \dots, v_{n+1}$ . The former polygon can be partitioned into triangles, with no intersecting diagonals, in  $t_i$  ways; the latter polygon in  $t_{n+1-i+1} = t_{n+2-i}$  ways. This results in a total of  $t_i \cdot t_{n+2-i}$  triangular partitions with no overlapping diagonals. As  $i$  varies from 2 to  $n$  we have  $t_{n+1} = t_2 t_n + t_3 t_{n-1} + \dots + t_{n-1} t_3 + t_n t_2 = \sum_{i=2}^n t_i t_{n+2-i}$ .

(b) From Example 10.36,  $t_n = b_{n-2}$ ,  $n \geq 2$ . With  $b_n = (2n)! / [(n+1)!n!]$  we have  $t_n = (2n-4)! / [(n-1)!(n-2)!]$ ,  $n \geq 2$ .

7. (a)

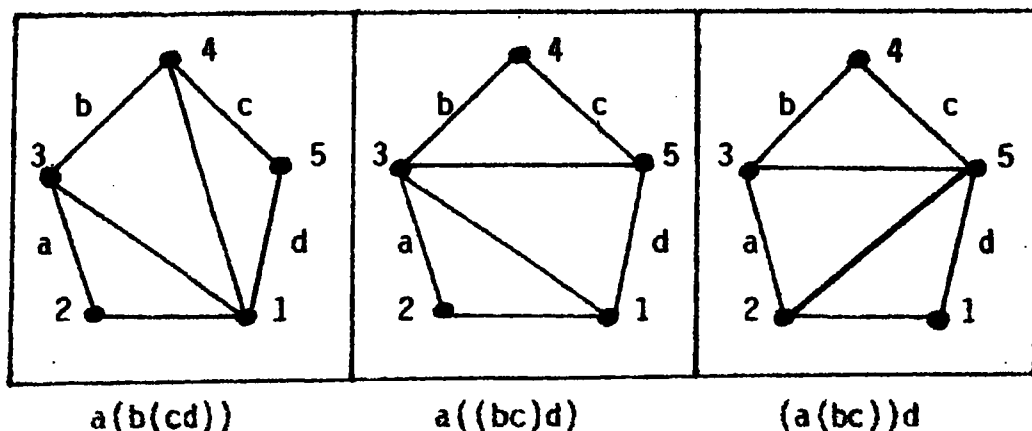

- (b) (iii)  $((ab)c)d$ e (iv)  $(ab)(c(de))$

8. (a)  $b_{n+1} = \left(\frac{1}{n+2}\right) \binom{2n+2}{n+1} = \left(\frac{1}{n+2}\right) \left[ \frac{(2n+2)!}{(n+1)!(n+1)!} \right] =$

$$\frac{(2n+2)(2n+1)(2n)!}{(n+2)(n+1)^2(n!)^2} = \frac{2(2n+1)}{(n+2)} \cdot \frac{(2n)!}{(n+1)(n!)^2} = \frac{2(2n+1)}{(n+2)} \left[ \frac{1}{n+1} \binom{2n}{n} \right]$$

$$= \frac{2(2n+1)}{(n+2)} b_n.$$

9. In Fig. 10.23 note how vertex 1 is always paired with an even numbered vertex. This must be the case for each  $n \geq 0$ , otherwise we end up with intersecting chords.

For each  $n \geq 1$ , let  $1 \leq k \leq n$ , so that  $2 \leq 2k \leq 2n$ . Drawing the chord connecting vertex 1 with vertex  $2k$ , we divide the circumference of the circle into two segments – one containing the vertices  $2, 3, \dots, 2k-1$ , and the other containing the vertices  $2k+1, 2k+2, \dots, 2n$ . These vertices can be connected by nonintersecting chords in  $a_{k-1}a_{n-k}$  ways, so

$$a_n = a_0 a_{n-1} + a_1 a_{n-2} + a_2 a_{n-3} + \dots + a_{n-2} a_1 + a_{n-1} a_0.$$

Since  $a_0 = 1, a_1 = 1, a_2 = 2$ , and  $a_3 = 5$ , we find that  $a_n = b_n$ , the  $n$ th Catalan number.

10. Consider, for example, the second mountain range in Fig. 10.24. This path is made up from the moves N S N N S S. Replace each 'N' by a '1' and each 'S' by a '0' to get 1 0 1 1 0 0 – a sequence of three 1's and three 0's, where the number of 0's never exceeds the number of 1's as the sequence is read from left to right. We know that the number of such sequences is  $5 (= b_3)$ . In general, for  $n \in \mathbb{N}$ , there are  $b_n$  such sequences and, consequently,  $b_n$  such mountain ranges. [Note: the above argument could also be established by replacing 'N' by 'push' and 'S' by 'pop', setting up a one-to-one correspondence between the mountain ranges and the permutations obtained with the stack.]

11.

(a)	$x$	$f_1(x)$	$f_2(x)$	$f_3(x)$	$f_4(x)$	$f_5(x)$
	1	1	3	2	2	1
	2	2	3	2	3	3
	3	3	3	3	3	3

(b) The functions in part (a) correspond with the following paths from  $(0, 0)$  to  $(3, 3)$ .

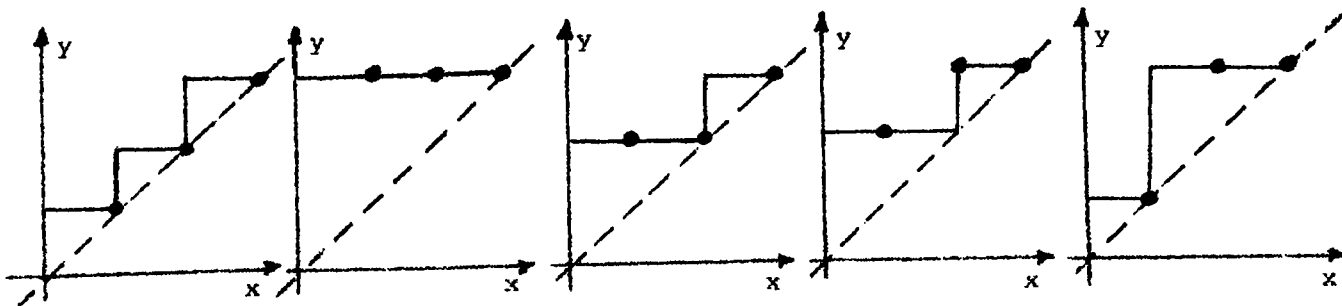

(c) The mountain ranges in Fig. 10.24 of the text.

(d) For  $n \in \mathbb{Z}^+$ , the number of monotone increasing functions  $f : \{1, 2, 3, \dots, n\} \rightarrow \{1, 2, 3, \dots, n\}$  where  $f(i) \geq i$  for all  $1 \leq i \leq n$ , is  $b_n = (1/(n+1)) \binom{2n}{n}$ , the  $n$ -th Catalan number. This follows from Exercise 3 in Section 1.5. There is a one-to-one correspondence between the paths described in that exercise and the functions being dealt with here.

12.

(a)	$x$	$g_1(x)$	$g_2(x)$	$g_3(x)$	$g_4(x)$	$g_5(x)$
	1	1	1	1	1	1
	2	2	1	2	1	1
	3	3	1	2	2	3

(b) For  $1 \leq i \leq 5$ ,  $f_i$  [in part (a) of the previous exercise] corresponds with  $g_i$ . We demonstrate the correspondence for  $i = 1, 2$ , and 4.

( $i = 1$ )		( $i = 2$ )		( $i = 4$ )				
$x$	$f_1(x)$	$g_1(x)$	$x$	$f_2(x)$	$g_2(x)$	$x$	$f_4(x)$	$g_4(x)$
1	1	1	1	3	1	1	2	1
2	2	2	2	3	1	2	3	1
3	3	3	3	3	1	3	3	2

Consider the column for any  $f_i$ . In that column replace each entry  $k$  by  $3 - (k - 1)$ : so 1's and 3's are interchanged while 2's remain as 2's. Then reverse the order of this new column. The result is the column for  $g_i$ . [In order to generalize this to the case where the domain and codomain are  $\{1, 2, 3, \dots, n\}$ ,  $n \in \mathbb{Z}^+$ , we write down two columns — one for  $1, 2, 3, \dots, n$  and another listing  $f_i(1), f_i(2), f_i(3), \dots, f_i(n)$ . Each entry  $k$  [in the column for  $f_i$ ] is replaced by  $n - (k - 1)$ . Then the order of the column is reversed, giving us the image under the corresponding function  $g_i$ .

(c) For  $n \in \mathbb{Z}^+$ , the number of monotone increasing functions  $g : \{1, 2, 3, \dots, n\} \rightarrow \{1, 2, 3, \dots, n\}$ , where  $g(i) \leq i$  for all  $1 \leq i \leq n$ , is  $(1/(n + 1))\binom{2n}{n} = b_n$ , the  $n$ -th Catalan number.

13. For  $n \in \mathbb{N}$ , let  $a_n$  count the number of these arrangements for a row of  $n$  contiguous pennies. Here  $a_0 = 1$ ,  $a_1 = 1$ ,  $a_2 = 2$ , and  $a_3 = 5$ . For the general situation, let  $n \in \mathbb{N}$  and consider a contiguous row of  $n + 1$  pennies. These  $n + 1$  pennies provide  $n$  possible locations for placing a penny on the second level. There are two cases to consider:

(1) The first location (as the second level is scanned from left to right) that is empty is at position  $i$ , where  $1 \leq i \leq n$ . So there are  $i - 1$  pennies (above the first  $i$  pennies in the bottom contiguous row) in the positions to the left of position  $i$ . These  $i - 1$  contiguous pennies provide  $a_{i-1}$  possible arrangements. The  $n - [(i - 1) + 1] = n - i$  positions (on the second level) to the right of position  $i$  are determined by a row of  $n - i + 1$  contiguous pennies at the bottom level and these  $n - i + 1$  contiguous pennies provide  $a_{n-i+1}$  arrangements. As  $i$  goes from 1 to  $n$  we get a total of

$$\sum_{i=1}^n a_{i-1} a_{n-i+1} = a_0 a_n + a_1 a_{n-1} + a_2 a_{n-2} + \dots + a_{n-1} a_1 \text{ arrangements.}$$

(2) The only situation not covered in case 1 occurs when there is no empty position on the second level. So we have a row of  $n + 1$  contiguous pennies on the bottom level and  $n$  contiguous pennies on the second level — and above these  $2n + 1$  pennies there are  $a_n (= a_n a_0)$  possible arrangements.

From cases (1) and (2) we have  $a_{n+1} = a_0 a_n + a_1 a_{n-1} + a_2 a_{n-2} + \dots + a_{n-1} a_1 + a_n a_0$ ,  $a_0 = 1$ , so  $a_n = b_n = (1/(n + 1))\binom{2n}{n}$ , the  $n$ th Catalan numbers.

14. (a)  $s_2 = 6$   
 (b)  $s_2 = \binom{4}{0}b_2 + \binom{3}{1}b_1 + \binom{2}{2}b_0$   
 (c)  $s_3 = \binom{6}{0}b_3 + \binom{5}{1}b_2 + \binom{4}{2}b_1 + \binom{3}{3}b_0 = 22$ .  
 (d) Consider those paths from  $(0,0)$  to  $(n,n)$  where there are  $r$  diagonal moves, for  $0 \leq r \leq n$ . How can one generate such a path? It must contain  $(n-r)$   $R$ 's and  $(n-r)$   $U$ 's and these  $2(n-r)$  letters provide 1 (location at the start)  $+2(n-r)-1$  [locations between the  $(n-r)$   $R$ 's and  $(n-r)$   $U$ 's]  $+1$  (location at the end)  $= 2(n-r)+1$  locations in total, for inserting the  $r$   $D$ 's. Further, these  $2(n-r)+1$  locations are selected with repetitions allowed. So there are  $\binom{2(n-r)+1+r-1}{r}b_{n-r} = \binom{2n-r}{r}b_{n-r}$  paths with  $r$   $D$ 's,  $n-r$   $R$ 's, and  $n-r$   $U$ 's (with the path never crossing the line  $y=x$ ). Summing over  $r$  we have  $s_n = \sum_{r=0}^n \binom{2n-r}{r}b_{n-r}$ .

15.

(a) 1 3 2, 2 3 1:  $E_3 = 2$

(b) 1 3 2 5 4	3 4 1 5 2
1 4 2 5 3	3 4 2 5 1
1 4 3 5 2	3 5 1 4 2
1 5 2 4 3	3 5 2 4 1
1 5 3 4 2	

2 3 1 5 4	4 5 1 3 2
2 4 1 5 3	4 5 2 3 1
2 4 3 5 1	
2 5 1 4 3	
2 5 3 4 1	$E_5 = 16$

(c) For each rise/fall permutation,  $n$  cannot be in the first position (unless  $n=1$ );  $n$  is the second component of a rise in such a permutation. Consequently,  $n$  must be at position 2 or 4 ... or  $2\lfloor n/2 \rfloor$ .

(d) Consider the location of  $n$  in a rise/fall permutation  $x_1x_2x_3 \dots x_{n-1}x_n$  of  $1, 2, 3, \dots, n$ . The number  $n$  is in position  $2i$  for some  $1 \leq i \leq \lfloor n/2 \rfloor$ . Here there are  $2i-1$  numbers that precede  $n$ . These can be selected in  $\binom{n-1}{2i-1}$  ways and give rise to  $E_{2i-1}$  rise/fall permutations. The  $(n-1)-(2i-1) = n-2i$  numbers that follow  $n$  give rise to  $E_{n-2i}$  rise/fall permutations. Consequently,  $E_n = \sum_{i=1}^{\lfloor n/2 \rfloor} \binom{n-1}{2i-1} E_{2i-1} E_{n-2i}$ ,  $n \geq 2$ .

(e) Comparable to part (c), here we realize that for  $n \geq 2$ , 1 is at the end of the permutation or is the first component of a rise in such a permutation. Therefore, 1 must be at position 1 or 3 or ... or  $2\lfloor (n-1)/2 \rfloor + 1$ .

(f) As in part (d) look now for 1 in a rise/fall permutation of  $1, 2, 3, \dots, n$ . We find 1 is in position  $2i+1$  for some  $0 \leq i \leq \lfloor (n-1)/2 \rfloor$ . Here there are  $2i$  numbers that precede 1. These can be selected in  $\binom{n-1}{2i}$  ways and give rise to  $E_{2i}$  rise/fall permutations. The

remaining  $(n-1) - 2i = n - 2i - 1$  numbers that follow 1 give rise to  $E_{n-2i-1}$  rise/fall permutations. Therefore,  $E_n = \sum_{i=0}^{\lfloor (n-1)/2 \rfloor} \binom{n-1}{2i} E_{2i} E_{n-2i-1}$ ,  $n \geq 1$ .

(g) From parts (d) and (f) we have:

$$(d) E_n = \binom{n-1}{1} E_1 E_{n-2} + \binom{n-1}{3} E_3 E_{n-4} + \cdots + \binom{n-1}{2\lfloor n/2 \rfloor - 1} E_{2\lfloor n/2 \rfloor - 1} E_{n-2\lfloor n/2 \rfloor}$$

$$(f) E_n = \binom{n-1}{0} E_0 E_{n-1} + \binom{n-1}{2} E_2 E_{n-3} + \cdots + \binom{n-1}{2\lfloor (n-1)/2 \rfloor} E_{2\lfloor (n-1)/2 \rfloor} E_{n-2\lfloor (n-1)/2 \rfloor - 1}$$

Adding these equations we find that  $2E_n = \sum_{i=0}^{n-1} \binom{n-1}{i} E_i E_{n-i-1}$  or  $E_n =$

$$(1/2) \sum_{i=0}^{n-1} \binom{n-1}{i} E_i E_{n-i-1}.$$

$$E_6 = (1/2) \sum_{i=0}^5 \binom{5}{i} E_i E_{5-i}$$

$$= (1/2) \left[ \binom{5}{0} E_0 E_5 + \binom{5}{1} E_1 E_4 + \binom{5}{2} E_2 E_3 + \binom{5}{3} E_3 E_2 + \binom{5}{4} E_4 E_1 + \binom{5}{5} E_5 E_0 \right]$$

$$= (1/2) [1 \cdot 1 \cdot 16 + 5 \cdot 1 \cdot 5 + 10 \cdot 1 \cdot 2 + 10 \cdot 2 \cdot 1 + 5 \cdot 5 \cdot 1 + 1 \cdot 16 \cdot 1]$$

$$(h) = (1/2) [16 + 25 + 20 + 20 + 25 + 16] = 61$$

$$E_7 = (1/2) \sum_{i=0}^6 \binom{6}{i} E_i E_{6-i}$$

$$= (1/2) [1 \cdot 1 \cdot 61 + 6 \cdot 1 \cdot 16 + 15 \cdot 1 \cdot 5 + 20 \cdot 2 \cdot 2 + 15 \cdot 5 \cdot 1 + 6 \cdot 16 \cdot 1 + 1 \cdot 61 \cdot 1]$$

$$= 272$$

(i) Consider the Maclaurin series expansions

$$\sec x = 1 + x^2/2! + 5x^4/4! + 61x^6/6! + \cdots \text{ and}$$

$$\tan x = x + 2x^3/3! + 16x^5/5! + 272x^7/7! + \cdots$$

One finds that  $\sec x + \tan x$  is the exponential generating function of the sequence 1, 1, 1, 2, 5, 16, 61, 272, ... - namely, the sequence of Euler numbers.

## Section 10.6

1. (a)  $f(n) = (5/3)(4n^{\log_3 4} - 1)$  and  $f \in O(n^{\log_3 4})$  for  $n \in \{3^i | i \in \mathbb{N}\}$

(b)  $f(n) = 7(\log_5 n + 1)$  and  $f \in O(\log_5 n)$  for  $n \in \{5^i | i \in \mathbb{N}\}$

2. As in the proof of Theorem 10.1 we find that  $f(n) = a^k f(1) + c[1 + a + a^2 + \cdots + a^{k-1}] = a^k d + c[1 + a + a^2 + \cdots + a^{k-1}]$ .

(a) For  $a = 1$ ,  $f(n) = d + ck = d + c \log_b n$ , since  $n = b^k$ .

(b) For  $a > 1$ ,  $f(n) = a^k d + c[(a^k - 1)/(a - 1)]$

$$n = b^k \implies k = \log_b n$$

$$a^k = a^{\log_b n} = n^x \implies \log_b (a^{\log_b n}) = \log_b n^x \implies (\log_b n)(\log_b a) = x(\log_b n) \implies x = \log_b a.$$

So for  $a > 1$ ,  $f(n) = dn^{\log_b a} + (c/(a-1))[n^{\log_b a} - 1]$ .

3. (a)  $f \in O(\log_b n)$  on  $\{b^k | k \in \mathbb{N}\}$

(b)  $f \in O(n^{\log_b a})$  on  $\{b^k | k \in \mathbb{N}\}$

4. (a)  $d = 0$ ,  $a = 2$ ,  $b = 5$ ,  $c = 3$

$$f(n) = 3\lceil n^{\log_5 2} - 1 \rceil$$

$$f \in O(n^{\log_5 2})$$

$$(b) \quad d = 1, a = 1, b = 2, c = 2$$

$$f(n) = 1 + 2 \log_5 n$$

$$f \in O(\log_5 n)$$

$$5. \quad (a) \quad f(1) = 0$$

$$f(n) = 2f(n/2) + 1$$

From Exercise 2(b),  $f(n) = n - 1$ .

(b) The equation  $f(n) = f(n/2) + (n/2)$  arises as follows: There are  $(n/2)$  matches played in the first round. Then there are  $(n/2)$  players remaining, so we need  $f(n/2)$  additional matches to determine the winner.

$$6. \quad (i) \quad \text{Corollary 10.1: From Theorem 10.1}$$

(1)  $f(n) = c(\log_b n + 1)$  for  $n = 1, b, b^2, \dots$ , when  $a = 1$ . Hence  $f \in O(\log_b n)$  on  $S = \{b^k | k \in \mathbf{N}\}$ .

(2)  $f(n) = \lceil c/(a-1) \rceil [an^{\log_b a} - 1]$  for  $n = 1, b, b^2, \dots$ , when  $a \geq 2$ . Therefore  $f \in O(n^{\log_b a})$  on  $S = \{b^k | k \in \mathbf{N}\}$ .

(ii) Theorem 10.2(b): Since  $f \in O(g)$  on  $S$ , and  $g \in O(n \log n)$ , it follows that  $f \in O(n \log n)$  on  $S$ . So by Definition 10.1 we know that there exist constants  $m \in \mathbf{R}^+$  and  $s \in \mathbf{Z}^+$  such that  $f(n) = |f(n)| \leq m|n \log n| = mn \log n$  for all  $n \in S$  where  $n \geq s$ . We need to find constants  $M \in \mathbf{R}^+$  and  $s_1 \in \mathbf{Z}^+$  so that  $f(n) \leq Mn \log n$  for all  $n \geq s_1$  - not just those  $n \in S$ .

Choose  $t \in \mathbf{Z}^+$  so that  $s < b^k < t < b^{k+1}$  (and  $\log s \geq 1$ ). Since  $f$  is monotone increasing and positive,

$$\begin{aligned} f(t) \leq f(b^{k+1}) &\leq m b^{k+1} \log(b^{k+1}) \\ &= m b^{k+1} [\log b^k + \log b] \\ &= m b^{k+1} \log b^k + m b^{k+1} \log b \\ &= m b [b^k (\log b^k + \log b)] \\ &< m b [b^k \log b^k (1 + \log b)] \\ &= m b (1 + \log b) (b^k \log b^k) \\ &< m b (1 + \log b) t \log t \end{aligned}$$

So with  $M = m b (1 + \log b)$ , and  $s_1 = b^k + 1$ , we find that for all  $t \in \mathbf{Z}^+$ , if  $t \geq s_1$  then  $f(t) < M(t \log t)$  (so  $f(t) \leq M(t \log t)$ , and  $f \in O(n \log n)$ ).

$$7. \quad O(1)$$

8. (a) Here  $f(1) = 0, f(2) = 1, f(3) = 3, f(4) = 4$ , so  $f(1) \leq f(2) \leq f(3) \leq f(4)$ . To show that  $f$  is monotone increasing we shall use the Alternative Form of the Principle of Mathematical Induction. We assume that for all  $i, j \in \{1, 2, 3, \dots, n\}$ ,  $j > i \implies f(j) \geq f(i)$ . Now we consider the case for  $n+1$ , where  $n \geq 4$ .

(Case 1:  $n+1$  is odd) Here we write  $n+1 = 2k+1$  and have  $f(n+1) = f(k+1) + f(k) + 2 \geq$

$f(k) + f(k) + 2 = f(2k) = f(n)$ , since  $k, k+1 < n$ , and by the induction hypothesis  $f(k+1) \geq f(k)$ .

(Case 2:  $n+1$  is even) Now we write  $n+1 = 2r$ , where  $r \in \mathbb{Z}^+$  (and  $r \geq 3$ ). Then  $f(n+1) = f(2r) = f(r) + f(r) + 2f(r) + f(r-1) + 2 = f(2r-1) = f(n)$ , because  $f(r) \geq f(r-1)$  by the induction hypothesis.

Therefore  $f$  is a monotone increasing function.

(b) From part (a), Example 10.48, and Theorem 10.2 (c) it follows that  $f \in O(n)$  for all  $n \in \mathbb{Z}^+$ .

9. (a)

$$\begin{aligned} f(n) &\leq af(n/b) + cn \\ af(n/b) &\leq a^2f(n/b^2) + ac(n/b) \\ a^2f(n/b^2) &\leq a^3f(n/b^3) + a^2c(n/b^2) \\ a^3f(n/b^3) &\leq a^4f(n/b^4) + a^3c(n/b^3) \\ &\vdots \\ a^{k-1}f(n/b^{k-1}) &\leq a^k f(n/b^k) + a^{k-1}c(n/b^{k-1}) \end{aligned}$$

Hence  $f(n) \leq a^k f(n/b^k) + cn[1 + (a/b) + (a/b)^2 + \dots + (a/b)^{k-1}] = a^k f(1) + cn[1 + (a/b) + (a/b)^2 + \dots + (a/b)^{k-1}]$ , since  $n = b^k$ . Since  $f(1) \leq c$  and  $(n/b^k) = 1$ , we have  $f(n) \leq cn[1 + (a/b) + (a/b)^2 + \dots + (a/b)^{k-1} + (a/b)^k] = (cn) \sum_{i=0}^k (a/b)^i$ .

(b) When  $a = b$ ,  $f(n) \leq (cn) \sum_{i=0}^k 1^i = (cn)(k+1)$ , where  $n = b^k$ , or  $k = \log_b n$ . Hence  $f(n) \leq (cn)(\log_b n + 1)$  so  $f \in O(n \log_b n) = O(n \log n)$ , for any base greater than 1.

$$\begin{aligned} \text{(c) For } a \neq b, cn \sum_{i=0}^k (a/b)^i &= cn \left[ \frac{1 - (a/b)^{k+1}}{1 - (a/b)} \right] \\ &= (c)(b^k) \left[ \frac{1 - (a/b)^{k+1}}{1 - (a/b)} \right] = c \left[ \frac{b^k - (a^{k+1}/b)}{1 - (a/b)} \right] = c \left[ \frac{b^{k+1} - a^{k+1}}{b - a} \right] = \\ &= c \left[ \frac{a^{k+1} - b^{k+1}}{a - b} \right]. \end{aligned}$$

(d) From part (c),  $f(n) \leq (c/(a-b))[a^{k+1} - b^{k+1}] = (ca/(a-b))a^k - (cb/(a-b))b^k$ . But  $a^k = a^{\log_b n} = n^{\log_b a}$  and  $b^k = n$ , so  $f(n) \leq (ca/(a-b))n^{\log_b a} - (cb/(a-b))n$ .

(i) When  $a < b$ , then  $\log_b a < 1$ , and  $f \in O(n)$  on  $\mathbb{Z}^+$ .

(ii) When  $a > b$ , then  $\log_b a > 1$ , and  $f \in O(n^{\log_b a})$  on  $\mathbb{Z}^+$ .

10. (a)  $a = 9, b = 3, n^{\log_b a} = n^{\log_3 9} = n^2$

$$h(n) = n \in O(n^{\log_3 9 - \epsilon}) \text{ for } \epsilon = 1.$$

So by case (i) for the Master Theorem we have  $f \in \Theta(n^2)$ .

$$(b) a = 2, b = 2, n^{\log_b a} = n^{\log_2 2} = n^1 = n$$

$$h(n) = 1 \in O(n^{\log_2 2 - \epsilon}) \text{ for } \epsilon = 1.$$

By case (i) for the Master Theorem it follows that  $f \in \Theta(n)$ .

$$(c) a = 1, b = 3/2, n^{\log_b a} = n^{\log_{3/2} 1} = n^0 = 1.$$

$$h(n) = 1 \in \Theta(n^{\log_{3/2} 1})$$

Here case (ii) for the Master Theorem applies and we find that  $f \in \Theta(n^{\log_b a} \log_2 n) = \Theta(\log_2 n)$ .

$$(d) a = 2, b = 3, n^{\log_b a} = n^{\log_3 2} \doteq n^{0.631}$$

$$h(n) = n \in \Omega(n^{\log_3 2 + \epsilon}) \text{ where } \epsilon \doteq 0.369.$$

Further, for all sufficiently large  $n$ ,  $a h(n/b) = 2h(n/3) = 2(n/3) = (2/3)n \leq (3/4)n = c h(n)$ , for  $0 < c = 3/4 < 1$ . Thus, case (iii) of the Master Theorem tells us that  $f \in \Theta(n)$ .

$$(e) a = 4, b = 2, n^{\log_b a} = n^{\log_2 4} = n^2$$

$$h(n) = n^2 \in \Theta(n^{\log_2 4})$$

From case (ii) of the Master Theorem we have  $f \in \Theta(n^{\log_2 4} \log_2 n) = \Theta(n^2 \log_2 n)$ .

### Supplementary Exercises

$$1. \binom{n}{k+1} = \frac{n!}{(k+1)!(n-k-1)!} = \frac{(n-k)}{(k+1)} \frac{n!}{k!(n-k)!} = \left(\frac{n-k}{k+1}\right) \binom{n}{k}$$

2. (a) Consider the element  $n+1$  in  $S = \{1, 2, 3, \dots, n, n+1\}$ . For each partition of  $S$  we consider the size of the subset containing  $n+1$ . If the size is 1, then  $n+1$  is by itself and there are  $B_n$  partitions where this happens. If the size is 2, there are  $\binom{n}{1} = n$  ways this can occur, and  $B_{n-1}$  ways to partition the other  $n-1$  integers. This results in  $\binom{n}{1} B_{n-1}$  partitions of  $S$ . In general, if  $n+1$  is in a subset of size  $i+1$ ,  $0 \leq i \leq n$ , there are  $\binom{n}{i}$  ways this can occur with  $\binom{n}{i} B_{n-i}$  resulting partitions of  $S$ . By the rule of sum  $B_{n+1} = \sum_{i=0}^n \binom{n}{i} B_{n-i} = \sum_{i=0}^n \binom{n}{n-i} B_{n-i} = \sum_{i=0}^n \binom{n}{i} B_i$ .

$$(b) \text{ For } n \geq 0, B_n = \sum_{i=0}^n S(n, i). \{S(0, 0) = 1\}.$$

3. There are two cases to consider. Case 1: (1 is a summand) - Here there are  $p(n-1, k-1)$  ways to partition  $n-1$  into exactly  $k-1$  summands. Case 2: (1 is not a summand) - Here each summand  $s_1, s_2, \dots, s_k > 1$ . For  $1 \leq i \leq k$ , let  $t_i = s_i - 1 \geq 1$ . Then  $t_1, t_2, \dots, t_k$  provide a partition of  $n-k$  into exactly  $k$  summands. These cases are exhaustive and disjoint, so by the rule of sum  $p(n, k) = p(n-1, k-1) + p(n-k, k)$ .

4. Here  $a_1 = 1$  and  $a_2 = 1$ .

For  $n \geq 3$  write  $n = x_1 + x_2 + \dots + x_t$ , where each  $x_i$ , for  $1 \leq i \leq t$ , is an odd positive integer (and  $1 \leq t \leq n$ , for  $n$  odd;  $2 \leq t \leq n$ , for  $n$  even). If  $x_1 = 1$ , then  $n-1 = x_2 + \dots + x_t$  and this summation is counted in  $a_{n-1}$ . If  $x_1 \neq 1$ , then

$x_1 \geq 3$  and  $n-2 = (x_1 - 2) + x_2 + \dots + x_i$ , a summation counted in  $a_{n-2}$ . Consequently,  $a_n = a_{n-1} + a_{n-2}$  for all  $n \geq 3$ , and  $a_n = F_n$ , the  $n$ th Fibonacci number, for  $n \geq 1$ .

5. (a)

$$A^2 = \begin{bmatrix} 2 & 1 \\ 1 & 1 \end{bmatrix} = \begin{bmatrix} F_3 & F_2 \\ F_2 & F_1 \end{bmatrix}, \quad A^3 = \begin{bmatrix} 3 & 2 \\ 2 & 1 \end{bmatrix} = \begin{bmatrix} F_4 & F_3 \\ F_3 & F_2 \end{bmatrix},$$

$$A^4 = \begin{bmatrix} 5 & 3 \\ 3 & 2 \end{bmatrix} = \begin{bmatrix} F_5 & F_4 \\ F_4 & F_3 \end{bmatrix}.$$

(b) Conjecture: For  $n \in \mathbb{Z}^+$ ,  $A^n = \begin{bmatrix} F_{n+1} & F_n \\ F_n & F_{n-1} \end{bmatrix}$ ,

where  $F_n$  denotes the  $n$ th Fibonacci number.

Proof: For  $n = 1$ ,  $A = A^1 = \begin{bmatrix} 1 & 1 \\ 1 & 0 \end{bmatrix} = \begin{bmatrix} F_2 & F_1 \\ F_1 & F_0 \end{bmatrix}$ , so the result is true in

this first case. Assume the result true for  $n = k \geq 1$ , i.e.,

$$A^k = \begin{bmatrix} F_{k+1} & F_k \\ F_k & F_{k-1} \end{bmatrix}. \quad \text{For } n = k+1, A^n = A^{k+1} = A^k \cdot A = \begin{bmatrix} F_{k+1} & F_k \\ F_k & F_{k-1} \end{bmatrix} \begin{bmatrix} 1 & 1 \\ 1 & 0 \end{bmatrix}$$

$$= \begin{bmatrix} F_{k+1} + F_k & F_{k+1} \\ F_k + F_{k-1} & F_k \end{bmatrix} = \begin{bmatrix} F_{k+2} & F_{k+1} \\ F_{k+1} & F_k \end{bmatrix}.$$

Consequently, the result is true for all  $n \in \mathbb{Z}^+$  by the Principle of Mathematical Induction.

6. (a)  $M = \begin{bmatrix} 1 & 1 \\ 1 & 2 \end{bmatrix}$ ,  $M^2 = \begin{bmatrix} 2 & 3 \\ 3 & 5 \end{bmatrix}$ ,  $M^3 = \begin{bmatrix} 5 & 8 \\ 8 & 13 \end{bmatrix}$ ,  $M^4 = \begin{bmatrix} 13 & 21 \\ 21 & 34 \end{bmatrix}$ .

(b)  $M = \begin{bmatrix} 1 & 1 \\ 1 & 2 \end{bmatrix} = \begin{bmatrix} F_1 & F_2 \\ F_2 & F_3 \end{bmatrix}$        $M^2 = \begin{bmatrix} 2 & 3 \\ 3 & 5 \end{bmatrix} = \begin{bmatrix} F_3 & F_4 \\ F_4 & F_5 \end{bmatrix}$

$$M^3 = \begin{bmatrix} 5 & 8 \\ 8 & 13 \end{bmatrix} = \begin{bmatrix} F_5 & F_6 \\ F_6 & F_7 \end{bmatrix} \quad M^4 = \begin{bmatrix} 13 & 21 \\ 21 & 34 \end{bmatrix} = \begin{bmatrix} F_7 & F_8 \\ F_8 & F_9 \end{bmatrix}$$

We claim that for  $n \in \mathbb{Z}^+$ ,  $M^n = \begin{bmatrix} F_{2n-1} & F_{2n} \\ F_{2n} & F_{2n+1} \end{bmatrix}$ .

Proof: We see that the claim is true for  $n = 1$  (as well as, 2, 3, and 4). Assume the result true for  $k(\geq 1)$  and consider what happens when  $n = k + 1$ .

$$M^n = \begin{bmatrix} 1 & 1 \\ 1 & 2 \end{bmatrix}^{k+1} = \begin{bmatrix} 1 & 1 \\ 1 & 2 \end{bmatrix} \begin{bmatrix} 1 & 1 \\ 1 & 2 \end{bmatrix}^k = \begin{bmatrix} 1 & 1 \\ 1 & 2 \end{bmatrix} \begin{bmatrix} F_{2k-1} & F_{2k} \\ F_{2k} & F_{2k+1} \end{bmatrix}$$

$$\begin{aligned}
&= \begin{bmatrix} F_{2k-1} + F_{2k} & F_{2k} + F_{2k+1} \\ F_{2k-1} + 2F_{2k} & F_{2k} + 2F_{2k+1} \end{bmatrix} \\
&= \begin{bmatrix} F_{2k+1} & F_{2k+2} \\ (F_{2k-1} + F_{2k}) + F_{2k} & (F_{2k} + F_{2k+1}) + F_{2k+1} \end{bmatrix} \\
&= \begin{bmatrix} F_{2k+1} & F_{2k+2} \\ F_{2k+1} + F_{2k} & F_{2k+2} + F_{2k+1} \end{bmatrix} = \begin{bmatrix} F_{2k+1} & F_{2k+2} \\ F_{2k+2} & F_{2k+3} \end{bmatrix} \\
&= \begin{bmatrix} F_{2n-1} & F_{2n} \\ F_{2n} & F_{2n+1} \end{bmatrix}.
\end{aligned}$$

It follows from the Principle of Mathematical Induction that  $M^n = \begin{bmatrix} F_{2n-1} & F_{2n} \\ F_{2n} & F_{2n+1} \end{bmatrix}$  for all  $n \geq 1$ .

7. From  $x^2 - 1 = 1 + \frac{1}{x}$  we find that  $x^3 - x = x + 1$ , or  $x^3 - 2x - 1 = 0$ . Since  $(-1)^3 - 2(-1) - 1 = -1 + 2 - 1 = 0$ , it follows that  $-1$  is a root of  $x^3 - 2x - 1$ . Consequently,  $x - (-1) = x + 1$  is a factor and we have  $x^3 - 2x - 1 = (x + 1)(x^2 - x - 1)$ . So the roots of  $x^3 - 2x - 1$  are  $-1, (1 + \sqrt{5})/2$ , and  $(1 - \sqrt{5})/2$ .

For  $x = -1, y = (-1)^2 - 1 = 0$ .

For  $x = (1 + \sqrt{5})/2, y = [(1 + \sqrt{5})/2]^2 - 1 = (1/4)(6 + 2\sqrt{5}) - 1 = [(3 + \sqrt{5})/2] - 1 = (1 + \sqrt{5})/2$ .

For  $x = (1 - \sqrt{5})/2, y = [(1 - \sqrt{5})/2]^2 - 1 = (1/4)(6 - 2\sqrt{5}) - 1 = [(3 - \sqrt{5})/2] - 1 = (1 - \sqrt{5})/2$ .

So the points of intersection are  $(-1, 0), ((1 + \sqrt{5})/2, (1 + \sqrt{5})/2) = (\alpha, \alpha)$ , and  $((1 - \sqrt{5})/2, (1 - \sqrt{5})/2) = (\beta, \beta)$ .

8. (a)  $\alpha^2 = (1 + \sqrt{5})^2/4 = (6 + 2\sqrt{5})/4 = (3 + \sqrt{5})/2$

$$\alpha + 1 = (1 + \sqrt{5})/2 + 1 = (3 + \sqrt{5})/2$$

$$\beta^2 = (1 - \sqrt{5})^2/4 = (6 - 2\sqrt{5})/4 = (3 - \sqrt{5})/2$$

$$\beta + 1 = (1 - \sqrt{5})/2 + 1 = (3 - \sqrt{5})/2$$

$$(b) \sum_{k=0}^n \binom{n}{k} F_k = \sum_{k=0}^n \binom{n}{k} (\alpha^k - \beta^k) / (\alpha - \beta)$$

$$= [1/(\alpha - \beta)] [\sum_{k=0}^n \binom{n}{k} \alpha^k - \sum_{k=0}^n \binom{n}{k} \beta^k]$$

$$= [1/(\alpha - \beta)] [(1 + \alpha)^n - (1 + \beta)^n] = [1/(\alpha - \beta)] [(\alpha^2)^n - (\beta^2)^n]$$

$$= (\alpha^{2n} - \beta^{2n}) / (\alpha - \beta) = F_{2n}$$

$$(c) \alpha^3 = \alpha(\alpha^2) = [(1 + \sqrt{5})/2][(3 + \sqrt{5})/2] = (8 + 4\sqrt{5})/4 = 2 + \sqrt{5}$$

$$1 + 2\alpha = 1 + 2[(1 + \sqrt{5})/2] = 2 + \sqrt{5}$$

$$\beta^3 = \beta(\beta^2) = [(1 - \sqrt{5})/2][(3 - \sqrt{5})/2] = (8 - 4\sqrt{5})/4 = 2 - \sqrt{5}$$

$$1 + 2\beta = 1 + 2[(1 - \sqrt{5})/2] = 2 - \sqrt{5}$$

$$(d) \sum_{k=0}^n \binom{n}{k} 2^k F_k = \sum_{k=0}^n \binom{n}{k} 2^k (\alpha^k - \beta^k) / (\alpha - \beta)$$

$$\begin{aligned}
&= [1/(\alpha - \beta)][\sum_{k=0}^n \binom{n}{k} 2^k \alpha^k - \sum_{k=0}^n \binom{n}{k} 2^k \beta^k] \\
&= [1/(\alpha - \beta)][\sum_{k=0}^n \binom{n}{k} (2\alpha)^k - \sum_{k=0}^n \binom{n}{k} (2\beta)^k] \\
&= [1/(\alpha - \beta)][(1 + 2\alpha)^n - (1 + 2\beta)^n] = [1/(\alpha - \beta)][\alpha^{3n} - \beta^{3n}] = (\alpha^{3n} - \beta^{3n})/(\alpha - \beta) = F_{3n}.
\end{aligned}$$

9. (a) Since  $\alpha^2 = \alpha + 1$ , it follows that  $\alpha^2 + 1 = 2 + \alpha$  and  $(2 + \alpha)^2 = 4 + 4\alpha + \alpha^2 = 4(1 + \alpha) + \alpha^2 = 5\alpha^2$ .  
(b) Since  $\beta^2 = \beta + 1$  we find that  $\beta^2 + 1 = \beta + 2$  and  $(2 + \beta)^2 = 4 + 4\beta + \beta^2 = 4(1 + \beta) + \beta^2 = 5\beta^2$ .

$$\begin{aligned}
(c) \quad \sum_{k=0}^{2n} \binom{2n}{k} F_{2k+m} &= \sum_{k=0}^{2n} \binom{2n}{k} \left[ \frac{\alpha^{2k+m} - \beta^{2k+m}}{\alpha - \beta} \right] \\
&= (1/(\alpha - \beta)) \left[ \sum_{k=0}^{2n} \binom{2n}{k} (\alpha^2)^k \alpha^m - \sum_{k=0}^{2n} \binom{2n}{k} (\beta^2)^k \beta^m \right] \\
&= (1/(\alpha - \beta)) [\alpha^m (1 + \alpha^2)^{2n} - \beta^m (1 + \beta^2)^{2n}] \\
&= (1/(\alpha - \beta)) [\alpha^m (2 + \alpha)^{2n} - \beta^m (2 + \beta)^{2n}] \\
&= (1/(\alpha - \beta)) [\alpha^m ((2 + \alpha)^2)^n - \beta^m ((2 + \beta)^2)^n] \\
&= (1/(\alpha - \beta)) [\alpha^m (5\alpha^2)^n - \beta^m (5\beta^2)^n] \\
&= 5^n (1/(\alpha - \beta)) [\alpha^{2n+m} - \beta^{2n+m}] = 5^n F_{2n+m}.
\end{aligned}$$

10. (a) Let  $p_0 = \$4000$ , the price first set by Renu, and let  $p_1 = \$3000$ , the first offer made by Narmada. For  $n \geq 0$ , we have

$$p_{n+2} = (1/2)(p_{n+1} + p_n).$$

This gives us the characteristic equation  $2x^2 - x - 1 = 0$ ; the characteristic roots are 1 and  $-1/2$ . So

$$p_n = A(1)^n + B(-1/2)^n, \quad n \geq 0.$$

From  $p_0 = 4000$ ,  $p_1 = 3000$  it follows that  $A = 10,000/3$ ,  $B = 2000/3$ .

Narmada's fifth offer occurs for  $n = 9 (= 2 \cdot 5 - 1)$  and  $p_9 = \$3332.03$ . Her 10th offer occurs for  $n = 19$  and  $p_{19} = \$3333.33$ . For  $k \geq 1$ , her  $k$ th offer occurs when  $n = 2k - 1$  and  $p_n = (10,000/3) + (2000/3)(-1/2)^{2k-1}$ .

(b) As  $n$  increases the term  $(-1/2)^n$  decreases to 0, so  $p(n)$  approaches  $\$10,000/3 = \$3333.33$ .

(c) Here  $p_n = A(1)^n + B(-1/2)^n$ ,  $n \geq 0$ , with  $p_0 = \$4000$ . As  $n$  increases  $p_n$  approaches  $A = \$3200$ . So  $4000 = p_0 = 3200 + B$ , and  $B = 800$ .

With  $p_n = 3200 + 800(-1/2)^n$  we find the solution  $p_1 = 3200 + 800(-1/2) = \$2800$ .

11. Consider the case where  $n$  is even. (The argument for  $n$  odd is similar.) For the fence  $\mathcal{F}_n = \{a_1, a_2, \dots, a_n\}$ , there are  $c_{n-1}$  order-preserving functions  $f : \mathcal{F}_n \rightarrow \{1, 2\}$  where  $f(a_n) = 2$ . [Note that  $(\{1, 2\}, \leq)$  is the same partial order as  $\mathcal{F}_2$ .] When such a function satisfies  $f(a_n) = 1$ , then we must have  $f(a_{n-1}) = 1$ , and there are  $c_{n-2}$  of these order-preserving functions. Consequently, since these two cases have nothing in common and cover all possibilities, we find that

$$c_n = c_{n-1} + c_{n-2}, \quad c_1 = 2, \quad c_2 = 3.$$

So  $c_n = F_{n+2}$ , the  $(n+2)$ nd Fibonacci number.

12. This combinatorial identity follows by observing that  $F_{n+2}$  and  $\sum_{k=0}^m \binom{n-k+1}{k}$ , for  $m = \lfloor (n+1)/2 \rfloor$ , each count the number of subsets of  $\{1, 2, 3, \dots, n\}$  that contain no consecutive integers.
13. (a) For  $n \geq 1$ , let  $a_n$  count the number of ways one can tile a  $1 \times n$  chessboard using the  $1 \times 1$  white tiles and  $1 \times 2$  blue tiles. Then  $a_1 = 1$  and  $a_2 = 2$ .

For  $n \geq 3$ , consider the  $n$ th square (at the right end) of the  $1 \times n$  chessboard. Two situations are possible here:

- (1) This square is covered by a  $1 \times 1$  white tile, so the preceding  $n-1$  squares (of the  $1 \times n$  chessboard) can be covered in  $a_{n-1}$  ways;
- (2) This square and the preceding  $((n-1)$ st) square are both covered by a  $1 \times 2$  blue tile, so the preceding  $n-2$  squares (of the  $1 \times n$  chessboard) can be covered in  $a_{n-2}$  ways. These two situations cover all possibilities and are disjoint, so we have

$$a_n = a_{n-1} + a_{n-2}, \quad n \geq 3, \quad a_1 = 1, \quad a_2 = 2.$$

Consequently,  $a_n = F_{n+1}$ , the  $(n+1)$ st Fibonacci number.

(b) (i) There is only  $1 = \binom{n}{0} = \binom{n-0}{n-2-0}$  way to tile the  $1 \times n$  chessboard using all white squares.

(ii) Consider the equation  $x_1 + x_2 + \dots + x_{n-1} = n-1$ , where  $x_i = 1$  for  $1 \leq i \leq n-1$ . We can select one of the  $x_i$ , where  $1 \leq i \leq n-1$ , in  $\binom{n-1}{1} = \binom{n-1}{n-2} = \binom{n-1}{n-2-1}$  ways. Increase the value of this  $x_i$  to 2 and we have

$$x_1 + x_2 + \dots + x_{n-1} = n.$$

In terms of our tilings we have  $i-1$  white tiles, then the one blue tile, and then  $n-i-1$  white tiles on the right of the blue tile - for a total of  $(i-1) + 1 + (n-i-1) = n-1$  tiles.

(iii) There are  $\binom{n-2}{2} = \binom{n-2}{n-4} = \binom{n-2}{n-2-2}$  tilings where we have exactly two blue tiles and  $n-4$  white ones.

(iv) Likewise we have  $\binom{n-3}{3} = \binom{n-3}{n-6} = \binom{n-3}{n-2-3}$  tilings that use 3 blue tiles and  $n-6$  white ones.

(v) For  $0 \leq k \leq \lfloor n/2 \rfloor$ , there are  $\binom{n-k}{k} = \binom{n-k}{n-2k}$  tilings with  $k$  blue tiles and  $n-2k$  white ones.

(c)  $F_{n+1} = \sum_{k=0}^{\lfloor n/2 \rfloor} \binom{n-k}{k} = \sum_{k=0}^{\lfloor n/2 \rfloor} \binom{n-k}{n-2k}$ . [Compare this result with the formula presented in the previous exercise.]

14.  $c^2 = 1 + \sqrt{1 + \sqrt{1 + \sqrt{1 + \sqrt{1 + \dots}}}} = 1 + c$ . So  $c^2 - c - 1 = 0$  and  $c = \alpha$  or  $c = \beta$ . Since  $c > 0$  it follows that  $c = \alpha = (1 + \sqrt{5})/2$ .

15. (a) For each derangement, 1 is placed in position  $i$ ,  $2 \leq i \leq n$ . Two things then occur.  
 Case 1: ( $i$  is in position 1) – Here the other  $n - 2$  integers are deranged in  $d_{n-2}$  ways. With  $n - 1$  choices for  $i$  this results in  $(n - 1)d_{n-2}$  such derangements.  
 Case 2: ( $i$  is not in position 1 (or position  $i$ )). Here we consider 1 as the new natural position for  $i$ , so there are  $n - 1$  elements to derange. With  $n - 1$  choices for  $i$  we have  $(n - 1)d_{n-1}$  derangements. Since the two cases are exhaustive and disjoint, the result follows from the rule of sum.

(b)  $d_0 = 1$                       (c)  $d_n - nd_{n-1} = d_{n-2} - (n - 2)d_{n-3}$

(d)  $d_n - nd_{n-1} = (-1)^i [d_{n-i} - (n - i)d_{n-i-1}]$

Let  $i = n - 2$ .

$d_n - nd_{n-1} = (-1)^{n-2} [d_2 - 2d_1] = (-1)^{n-2} = (-1)^n$

(e)  $d_n - nd_{n-1} = (-1)^n$

$(d_n - nd_{n-1})(x^n/n!) = (-1)^n(x^n/n!)$

$\sum_{n=2}^{\infty} (d_n - nd_{n-1})(x^n/n!) = \sum_{n=2}^{\infty} (-x)^n/n! = e^{-x} - 1 + x$

$\sum_{n=2}^{\infty} d_n x^n/n! - x \sum_{n=2}^{\infty} d_{n-1} x^{n-1}/(n-1)! = e^{-x} - 1 + x$

$[f(x) - d_1 x - d_0] - x[f(x) - d_0] = e^{-x} - 1 + x$

$f(x) - 1 - x f(x) + x = e^{-x} - 1 + x$  and  $f(x) = e^{-x}/(1 - x)$

16. Drawing the  $(n + 1)$ st oval,  $n \geq 0$ , we get  $2n$  new points of intersection which split the perimeter of this oval into  $2n$  segments. Each segment takes an existing region and divides it into two regions. So

$a_{n+1} = a_n + 2n$ ,  $n \geq 1$ ,  $a_1 = 2$ .

$a_n^{(k)} = A$ ,  $a_n^{(p)} = n(Bn + C)$

$(n + 1)[B(n + 1) + C] = n(Bn + C) + 2n \implies B(n^2 + 2n + 1) + Cn + C = Bn^2 + Cn + 2n \implies$

$2B + C = C + 2$ ,  $B + C = 0 \implies B = 1$ ,  $C = -1$ , so  $a_n = A + n^2 - n$ .  $2 = a_1 = A \implies$

$a_n = n^2 - n + 2 = 2\{n(n - 1)/2\} + 2$ .

17. (a)  $a_n = \binom{2n}{n}$

(b)  $(r + sx)^t = r^t(1 + (s/r)x)^t = r^t[\binom{t}{0} + \binom{t}{1}(s/r)x + \binom{t}{2}(s/r)^2x^2 + \dots] = a_0 + a_1x + a_2x^2 + \dots = 1 + 2x + 6x^2 + \dots$

$r^t = 1 \implies r = 1$

$\binom{t}{1}s = 2 = ts$ ,  $\binom{t}{2}s^2 = 6 = s^2[t(t - 1)/2] = s(t - 1) = 2 - s$ , so  $s = -4$ ,  $t = -1/2$ , and

$(1 - 4x)^{-1/2}$  generates  $\binom{2n}{n}$ ,  $n \geq 0$ .

(c) Let a coin be tossed  $2n$  times with the sequence of H's and T's counted in  $a_n$ . For  $1 \leq i \leq n$ , there is a smallest  $i$  where the number of H's equals the number of T's for the first time after  $2i$  tosses. This sequence of  $2i$  tosses is counted in  $b_i$ ; the given sequence of  $2n$  tosses is counted in  $a_{n-i}b_i$ . Since  $b_0 = 0$ , as  $i$  varies from 0 to  $n$ ,  
 $a_n = \sum_{i=0}^n a_i b_{n-i}$ .

(d) Let  $g(x) = \sum_{n=0}^{\infty} b_n x^n$ ,  $f(x) = \sum_{n=0}^{\infty} a_n x^n = (1-4x)^{-1/2}$ .

$$\sum_{n=1}^{\infty} a_n x^n = \sum_{n=1}^{\infty} (a_0 b_n + a_1 b_{n-1} + \dots + a_n b_0) x^n \implies f(x) - a_0 = f(x)g(x) \text{ or } g(x) = 1 - [1/f(x)] = 1 - (1-4x)^{1/2}.$$

$$(1-4x)^{1/2} = \left[ \binom{1/2}{0} + \binom{1/2}{1}(-4x) + \binom{1/2}{2}(-4x)^2 + \dots \right]$$

The coefficient of  $x^n$  in  $(1-4x)^{1/2}$  is  $\binom{1/2}{n}(-4)^n =$

$$\frac{(1/2)((1/2)-1)((1/2)-2)\cdots((1/2)-n+1)}{n!}(-4)^n = \frac{(-1)(1)(3)(5)\cdots(2n-3)}{n!}(2^n) =$$

$$\frac{(-1)(1)(3)\cdots(2n-3)(2)(4)\cdots(2n-2)(2n)}{n!n!} = \frac{(-1)}{(2n-1)} \frac{(2n)!}{n!n!} = [-1/(2n-1)] \binom{2n}{n}.$$

Consequently, the coefficient of  $x^n$  in  $g(x)$  is  $b_n = [1/(2n-1)] \binom{2n}{n}$ ,  $n \geq 1$ ,  $b_0 = 0$ .

18.  $|\beta| = \left| \frac{1-\sqrt{5}}{2} \right| = \frac{\sqrt{5}-1}{2} < 1$ , so  $\sum_{k=0}^{\infty} \beta^k = \frac{1}{1-\beta} = \frac{1}{1-(\frac{1-\sqrt{5}}{2})} = \frac{1}{\frac{1+\sqrt{5}}{2}} = \frac{2}{1+\sqrt{5}} \cdot \frac{1-\sqrt{5}}{1-\sqrt{5}} = \frac{2-2\sqrt{5}}{1-5} = \frac{-1+\sqrt{5}}{2} = -(\frac{1-\sqrt{5}}{2}) = -\beta$ .

Since  $\alpha + \beta = (\frac{1+\sqrt{5}}{2}) + (\frac{1-\sqrt{5}}{2}) = 1$ , it follows that  $\alpha - 1 = -\beta$ .

$$\sum_{k=0}^{\infty} |\beta|^k = \sum_{k=0}^{\infty} \left( \frac{\sqrt{5}-1}{2} \right)^k = \frac{1}{1-(\frac{\sqrt{5}-1}{2})} = \frac{1}{(\frac{3-\sqrt{5}}{2})} = \frac{2}{3-\sqrt{5}} \cdot \frac{3+\sqrt{5}}{3+\sqrt{5}} = \frac{6+2\sqrt{5}}{9-5} = \frac{6+2\sqrt{5}}{4} = \left(\frac{1}{2}\right)(3+\sqrt{5}),$$

$$\text{and } \alpha^2 = \left(\frac{1+\sqrt{5}}{2}\right)^2 = \left(\frac{6+2\sqrt{5}}{4}\right) = \left(\frac{1}{2}\right)(3+\sqrt{5}).$$

19. For  $x, y, z \in \mathbf{R}$ ,

$$f(f(x, y), z) = f(a+bxy+c(x+y), z) = a+b[(a+bxy+c(x+y))z] + c[(a+bxy+c(x+y))+z] \\ = a + ac + c^2x + bcxy + b^2xyz + bcxz + c^2y + bcyz + abz + cz, \text{ and}$$

$$f(x, f(y, z)) = f(x, a+byz+c(y+z)) \\ = a + b[x(a+byz+c(y+z))] + c[x+(a+byz+c(y+z))] \\ = a + ac + abx + cx + c^2y + c^2z + b^2xyz + bcxy + bcxz + bcyz.$$

$f$  associative  $\implies f(f(x, y), z) = f(x, f(y, z)) \implies c^2x + (ab+c)z = abx + cx + c^2z$ . With  $ab = 1$  it follows that

$$c^2x + z + cz = x + c^2z + cx, \text{ or } (c^2 - c - 1)x = (c^2 - c - 1)z.$$

Since  $x, z$  are arbitrary, we have  $c^2 - c - 1 = 0$ . Consequently,  $c = \alpha$  or  $c = \beta$ .

20. (a)  $\alpha - \beta = \left(\frac{1}{2}\right)(1 + \sqrt{5}) - \left(\frac{1}{2}\right)(1 - \sqrt{5}) = \sqrt{5}$

$$\alpha^2 - \alpha^{-2} = \left(\frac{1+\sqrt{5}}{2}\right)^2 - \left(\frac{2}{1+\sqrt{5}}\right)^2 = \frac{6+2\sqrt{5}}{4} - \frac{4}{6+2\sqrt{5}} = \frac{3+\sqrt{5}}{2} - \frac{2}{3+\sqrt{5}} \cdot \frac{3-\sqrt{5}}{3-\sqrt{5}} = \frac{3+\sqrt{5}}{2} - \frac{6-2\sqrt{5}}{4} = \left(\frac{1}{2}\right)(3 + \sqrt{5} - 3 + \sqrt{5}) = \sqrt{5}.$$

$$\beta^{-2} - \beta^2 = \left(\frac{2}{1-\sqrt{5}}\right)^2 - \left(\frac{1-\sqrt{5}}{2}\right)^2 = \frac{4}{6-2\sqrt{5}} - \frac{6-2\sqrt{5}}{4} = \frac{2}{3-\sqrt{5}} \cdot \frac{3+\sqrt{5}}{3+\sqrt{5}} - \frac{3-\sqrt{5}}{2} = \frac{6+2\sqrt{5}}{4} - \frac{3-\sqrt{5}}{2} = \left(\frac{1}{2}\right)(3 + \sqrt{5} - 3 + \sqrt{5}) = \sqrt{5}.$$

(b) Using the Binet form we have

$$\begin{aligned} F_{n+1}^2 - F_{n-1}^2 &= \left(\frac{\alpha^{n+1} - \beta^{n+1}}{\alpha - \beta}\right)^2 - \left(\frac{\alpha^{n-1} - \beta^{n-1}}{\alpha - \beta}\right)^2 \\ &= \frac{\alpha^{2n+2} + \beta^{2n+2} - 2(\alpha\beta)^{n+1} - \alpha^{2n-2} - \beta^{2n-2} + 2(\alpha\beta)^{n-1}}{(\alpha - \beta)^2} \\ &= \frac{\alpha^{2n}(\alpha^2 - \alpha^{-2}) - \beta^{2n}(\beta^{-2} - \beta^2)}{(\alpha - \beta)^2} \quad (\text{since } \alpha\beta = -1) \\ &= (\alpha^{2n} - \beta^{2n})/(\alpha - \beta) \quad [\text{from the results in part (a)}] = F_{2n}. \end{aligned}$$

(c) Here the base angles are  $60^\circ$  and the altitude is  $(1/2)(\sqrt{3})F_n$ . Consequently, the area of  $T$  is  $(1/2)(\sqrt{3}/2)F_n[F_{n-1} + F_{n+1}] = (\sqrt{3}/4)F_n[F_{n-1} + F_{n+1}]$ .

Returning to part (b) we find that  $F_{2n} = F_{n+1}^2 - F_{n-1}^2 = (F_{n+1} - F_{n-1})(F_{n+1} + F_{n-1}) = F_n F_{n+1} + F_n F_{n-1}$ . Consequently, the area of  $T = (\sqrt{3}/4)F_{2n}$ .

21. Since  $A \cap B = \emptyset$ ,  $Pr(\mathcal{S}) = Pr(A \cup B) = Pr(A) + Pr(B)$ . Consequently, we have  $1 = p + p^2$ , so  $p^2 + p - 1 = 0$  and  $p = (-1 \pm \sqrt{5})/2$ . Since  $(-1 - \sqrt{5})/2 < 0$  it follows that  $p = (-1 + \sqrt{5})/2 = -\beta$ .
22. The probability that Sandra wins is  $p + (1-p)(1-p)^2 p + (1-p)(1-p)^2(1-p)(1-p)^2 p + \dots = p[1 + (1-p)^3 + (1-p)^6 + (1-p)^9 + \dots] = p[1/[1 - (1-p)^3]]$ .

For the game to be fair we must have  $1/2 = p[1/[1 - (1-p)^3]]$ , so

$$\begin{aligned} p &= (1/2)[1 - (1-p)^3] \\ 2p &= [1 - (1-p)^3] = 1 - (1 - 3p + 3p^2 - p^3) \\ 2p &= 3p - 3p^2 + p^3, \text{ and} \\ 0 &= p^3 - 3p^2 + p = p(p^2 - 3p + 1). \end{aligned}$$

Since  $p > 0$ , it follows that  $p^2 - 3p + 1 = 0$ , or  $p = (3 \pm \sqrt{5})/2$ . Since  $p < 1$ , we find that

$$p = (3 - \sqrt{5})/2 = [(1 - \sqrt{5})/2]^2 = \beta^2.$$

23. Here  $a_1 = 1$  (for the string 0) and  $a_2 = 2$  (for the strings 00, 11). For  $n \geq 3$ , consider the  $n$ th bit of a binary string (of length  $n$ ) where there is no run of 1's of odd length.
- (i) If this bit is 0 then the preceding  $n - 1$  bits can arise in  $a_{n-1}$  ways; and
- (ii) If this bit is 1, then the  $(n - 1)$ st bit must also be 1 and the preceding  $n - 2$  bits can arise in  $a_{n-2}$  ways.

Since the situations in (i) and (ii) have nothing in common and cover all cases we have

$$a_n = a_{n-1} + a_{n-2}, \quad n \geq 3, a_1 = 1, a_2 = 2.$$

Here  $a_n = F_{n+1}$ ,  $n \geq 1$ , and so we have another instance where the Fibonacci numbers arise.

24. Here  $x_0 = a$ ,  $x_1 = b$ ,  $x_2 = x_1x_0 = ba$ ,  $x_3 = x_2x_1 = b^2a$ ,  $x_4 = x_3x_2 = b^3a^2$ , and  $x_5 = x_4x_3 = b^5a^3$ . These results suggest that  $x_0 = a$  and, for  $n \geq 1$ ,  $x_n = b^{F_n}a^{F_{n-1}}$ , where  $F_n$  denotes the  $n$ th Fibonacci number (for  $n \geq 1$ ). To establish this in general we proceed by mathematical induction. The result is true for  $n = 0$ , as well as for  $n = 1, 2, 3, 4, 5$ .

Assume the result true for  $n = 0, 1, 2, \dots, k-1, k$ , where  $k$  is a fixed (but arbitrary) positive integer. Hence  $x_{k-1} = b^{F_{k-1}}a^{F_{k-2}}$  and  $x_k = b^{F_k}a^{F_{k-1}}$ , so  $x_{k+1} = x_kx_{k-1} = (b^{F_k}a^{F_{k-1}})(b^{F_{k-1}}a^{F_{k-2}}) = b^{F_k+F_{k-1}}a^{F_{k-1}+F_{k-2}} = b^{F_{k+1}}a^{F_k}$ , by the recursive definition of the Fibonacci numbers. Consequently, by the alternative form of the Principle of Mathematical Induction the result is true for ( $n = 0$  and) all  $n \geq 1$ .

(Second Solution). For  $n \geq 0$  let  $y_n = \log x_n$ . Then  $y_0 = \log a$ ,  $y_1 = \log b$ , and  $y_n = y_{n+1} + y_{n-2}$ ,  $n \geq 2$ . So  $y_n = c_1\alpha^n + c_2\beta^n$ , where  $\alpha = (1 + \sqrt{5})/2$  and  $\beta = (1 - \sqrt{5})/2$ .

$$\log a = c_1 + c_2, \log b = c_1\alpha + c_2\beta \Rightarrow$$

$$c_2 = (-1/\sqrt{5})\log b + [(1 + \sqrt{5})/2\sqrt{5}]\log a,$$

$$c_1 = (1/\sqrt{5})\log b + [(-1 + \sqrt{5})/2\sqrt{5}]\log a,$$

where the base for the log function is 10 (although any positive real number, other than 1, may be used here for the base).

Consequently,

$$\begin{aligned} y_n &= c_1\alpha^n + c_2\beta^n \\ &= [(1/\sqrt{5})\log b + [(-1 + \sqrt{5})/2\sqrt{5}]\log a]\alpha^n \\ &\quad + [(-1/\sqrt{5})\log b + [(1 + \sqrt{5})/2\sqrt{5}]\log a]\beta^n, \quad \text{so} \\ x_n &= 10^{c_1\alpha^n + c_2\beta^n} \\ &= 10^{[(1/\sqrt{5})\log b + [(-1 + \sqrt{5})/2\sqrt{5}]\log a]\alpha^n} \\ &\quad \cdot 10^{[(-1/\sqrt{5})\log b + [(1 + \sqrt{5})/2\sqrt{5}]\log a]\beta^n} \\ &= a^{[(1 + \sqrt{5})/2\sqrt{5}]\alpha^n + [(-1 + \sqrt{5})/2\sqrt{5}]\beta^n} b^{(\alpha^n - \beta^n)/\sqrt{5}} \\ &= a^{(\alpha^{n-1} - \beta^{n-1})/\sqrt{5}} b^{(\alpha^n - \beta^n)/\sqrt{5}} \\ &= a^{F_{n-1}} b^{F_n}, \end{aligned}$$

since  $F_n = (\alpha^n - \beta^n)/(\alpha - \beta) = (\alpha^n - \beta^n)/\sqrt{5}$ .

- (a)  $(n = 0) F_1^2 - F_0F_1 - F_0^2 = 1^2 - 0 \cdot 1 - 0^2 = 1$   
 $(n = 1) F_2^2 - F_1F_2 - F_1^2 = 1^2 - 1 \cdot 1 - 1^2 = -1$   
 25.  $(n = 2) F_3^2 - F_2F_3 - F_2^2 = 2^2 - 1 \cdot 2 - 1^2 = 1$   
 $(n = 3) F_4^2 - F_3F_4 - F_3^2 = 3^2 - 2 \cdot 3 - 2^2 = -1$   
 (b) Conjecture: For  $n \geq 0$ ,

$$F_{n+1}^2 - F_nF_{n+1} - F_n^2 = \begin{cases} 1, & n \text{ even} \\ -1, & n \text{ odd} \end{cases}$$

(c) Proof: The result is true for  $n = 0, 1, 2, 3$ , by the calculations in part (a). Assume the result true for  $n = k (\geq 3)$ . There are two cases to consider - namely,  $k$  even and

$k$  odd. We shall establish the result for  $k$  even, the proof for  $k$  odd being similar. Our induction hypothesis tells us that  $F_{k+1}^2 - F_k F_{k+1} - F_k^2 = 1$ . When  $n = k + 1 (\geq 4)$  we find that  $F_{k+2}^2 - F_{k+1} F_{k+2} - F_{k+1}^2 = (F_{k+1} + F_k)^2 - F_{k+1}(F_{k+1} + F_k) - F_{k+1}^2 = F_{k+1}^2 + 2F_{k+1}F_k + F_k^2 - F_{k+1}^2 - F_{k+1}F_k - F_{k+1}^2 = F_{k+1}F_k + F_k^2 - F_{k+1}^2 = -[F_{k+1}^2 - F_k F_{k+1} - F_k^2] = -1$ . The result follows for all  $n \in \mathbb{N}$ , by the Principle of Mathematical Induction.

26. The answer is the number of subsets of  $\{1, 2, 3, \dots, n\}$  which contain no consecutive entries. We learned in Section 10.2 that this is  $F_{n+2}$ , the  $(n + 2)$ nd Fibonacci number.

27. (a)  $r(C_1, x) = 1 + x$                        $r(C_4, x) = 1 + 4x + 3x^2$   
 $r(C_2, x) = 1 + 2x$                        $r(C_5, x) = 1 + 5x + 6x^2 + x^3$   
 $r(C_3, x) = 1 + 3x + x^2$                        $r(C_6, x) = 1 + 6x + 10x^2 + 4x^3$

In general, for  $n \geq 3$ ,  $r(C_n, x) = r(C_{n-1}, x) + xr(C_{n-2}, x)$ .

(b)  $r(C_1, 1) = 2$                        $r(C_3, 1) = 5$                        $r(C_5, 1) = 13$   
 $r(C_2, 1) = 3$                        $r(C_4, 1) = 8$                        $r(C_6, 1) = 21$

[Note: For  $1 \leq i \leq n$ , if one "straightens out" the chessboard  $C_i$  in Fig. 10.28, the result is a  $1 \times i$  chessboard - like those studied in the previous exercise.]

28. For  $0 \leq n \leq 18$ , let  $p_n$  be the probability that Jill bankrupts Cathy when Jill has  $n$  quarters. Then  $p_0 = 0$  and  $p_{18} = 1$  and the answer to this problem is  $p_{10}$ . For  $0 < n < 18$ , if Jill has  $n$  quarters, then after playing another game of checkers,

$$p_n = \underbrace{(1/2)p_{n-1}}_{\text{Jill has lost the game}} + \underbrace{(1/2)p_{n+1}}_{\text{Jill wins the game}}$$

$p_{n+1} - 2p_n + p_{n-1} = 0$  has characteristic roots  $r = 1, 1$ , so  $p_n = A + Bn$ .  $p_0 = 0 \implies A = 0$ ,  $1 = p_{18} \implies B = 1/18$ , so  $p_n = n/18$ . Hence Jill has probability  $10/18 = 5/9$  of bankrupting Cathy.

29. (a) The partitions counted in  $f(n, m)$  fall into two categories:

(1) Partitions where  $m$  is a summand. These are counted in  $f(n - m, m)$ , for  $m$  may occur more than once.

(2) Partitions where  $m$  is not a summand - so that  $m - 1$  is the largest possible summand. These partitions are counted in  $f(n, m - 1)$ .

Since these two categories are exhaustive and mutually disjoint it follows that  $f(n, m) = f(n - m, m) + f(n, m - 1)$ .

(b)

Program Summands(input,output);

Var

n: integer;

```

Function f(n,m: integer): integer;
Begin
  If n=0 then
    f := 1
  Else if (n < 0) or (m < 1) then
    f := 0
  Else f := f(n,m-1) + f(n-m,m)
End; {of function f}

```

```

Begin
  Writeln ('What is the value of n?');
  Readln (n);
  Writeln ('What is the value of m?');
  Readln (m);
  Write ('There are ', f(n,m):0, ' partitions of ');
  Write (n:0, ' where ', m:0, ' is the largest ');
  Writeln ('summand possible.')
End.

```

(c)

```

Program Partitions(input,output);
Var
  n: integer;

```

```

Function f(n,m: integer): integer;
Begin
  If n=0 then
    f := 1
  Else if (n < 0) or (m < 1) then
    f := 0
  Else f := f(n,m-1) + f(n-m,m)
End; {of function f}

```

```

Begin
  Writeln ('What is the value of n?');
  Readln (n);
  Write ('For n = ', n :0, ' the number of ');
  Write ('partitions p(', n:0, ') is ', f(n,n):0, '.');
End.

```

30. Let  $|B| = n = 1$  and  $|A| = m$ . Then  $f : A \rightarrow B$  where  $f(a) = b$  for all  $a \in A$  and  $\{b\} = B$ , is the only onto function from  $A$  to  $B$ . Hence  $a(m, 1) = 1$ .

For  $m \geq n > 1$ ,  $n^m =$  the total number of functions  $f : A \rightarrow B$ . If  $1 \leq i \leq n - 1$ , there are  $\binom{n}{i} a(m, i)$  onto functions  $g$  with domain  $A$  and range a subset of  $B$  of size  $i$ . Furthermore, any function  $h : A \rightarrow B$  that is not onto is found among these functions  $g$ . Consequently,  $a(m, n) = n^m - \sum_{i=1}^{n-1} \binom{n}{i} a(m, i)$ .

31. The following program will print out the units digit of the first 130 Fibonacci numbers:  $F_0 - F_{129}$ .

Program Units(input, output);

Var

FibUnit: array[0..129] of integer;

i, j: integer;

Begin

FibUnit[0] := 0;

FibUnit[1] := 1;

For i := 2 to 129 do

FibUnit[i] := (FibUnit[i-1] + FibUnit[i-2]) Mod 10;

For i := 0 to 12 do

For j := 0 to 9 do

If j < 9 then

Write (FibUnit[10 \* i + j]: 4)

Else {j = 9}

Writeln (FibUnit[10 \* i + 9]: 4)

End.

**PART 3**

**GRAPH THEORY**

**AND**

**APPLICATIONS**

CHAPTER 11  
AN INTRODUCTION TO GRAPH THEORY

**Section 11.1**

1. (a) To represent the air routes traveled among a certain set of cities by a particular airline.  
(b) To represent an electrical network. Here the vertices can represent switches, transistors, etc., and an edge  $(x, y)$  indicates the existence of a wire connecting  $x$  to  $y$ .  
(c) Let the vertices represent a set of job applicants and a set of open positions in a corporation. Draw an edge  $(A, b)$  to denote that applicant  $A$  is qualified for position  $b$ . Then all open positions can be filled if the resulting graph provides a matching between the applicants and open positions.
2. (a)  $\{b, e\}, \{e, f\}, \{f, g\}, \{g, e\}, \{e, b\}, \{b, c\}, \{c, d\}$   
(b)  $\{b, e\}, \{e, f\}, \{f, g\}, \{g, e\}, \{e, d\}$   
(c)  $\{b, e\}, \{e, d\}$   
(d)  $\{b, e\}, \{e, f\}, \{f, g\}, \{g, e\}, \{e, b\}$   
(e)  $\{b, e\}, \{e, f\}, \{f, g\}, \{g, e\}, \{e, d\}, \{d, c\}, \{c, b\}$   
(f)  $\{b, a\}, \{a, c\}, \{c, b\}$
3. 6
4. We claim that  $\kappa(G) = 2$ . To verify this consider the following:
  - (1) Let  $C_1$  be the set of all vertices  $v \in V$  where the binary label of  $v$  has an even number of 1s. This includes the vertex  $z$  whose binary label is the  $n$ -tuple of all 0s. For any  $v_0 \in C_1$ , where  $v_0 \neq z$ , we can find a path from  $v_0$  to  $z$  as follows. Suppose that the binary label for  $v_0$  has  $2m$  1s, where  $2 \leq 2m \leq n$ . Change the first two 1s in the binary label for  $v_0$  to 0s and call the resulting vertex  $v_1$ . Then  $v_1 \in C_1$  and  $\{v_0, v_1\} \in E$ . Now change the first two 1s in the binary label for  $v_1$  to 0s and call the resulting vertex  $v_2$ . Once again  $v_2 \in C_1$  and  $\{v_0, v_1\} \in E$ . Continuing this process we reach the vertex  $v_m = z$  and find that  $\{v_{m-1}, v_m\} \in E$ , with  $v_{m-1} \in C_1$ . Hence each of the vertices in  $C_1 - \{z\}$  is connected to  $z$ .
  - (2) Now let  $C_2$  be the set of all vertices  $w \in V$  where the binary label for  $w$  has an odd number of 1s. Let  $z^* \in C_2$  where the binary label for  $z^*$  consists of a 1 followed by  $n - 1$  0s. For each  $w_0 \in C_2$ ,  $w_0 \neq z^*$ , one of two possibilities can occur:
    - (i) There are  $2m + 1$  1s in the binary label for  $w_0$ , with  $3 \leq 2m + 1 \leq n$ , and the first entry in the label for  $w_0$  is 1. Here we change the next two 1s in the binary label for  $w_0$  to 0s and obtain the vertex  $w_1 \in C_2$  with  $\{w_0, w_1\} \in E$ . Now the first entry in the binary label

for  $w_1$  is a 1 and upon changing the second and third 1s in this label to 0s we obtain the vertex  $w_2 \in C_2$  with  $\{w_1, w_2\} \in E$ . Continuing this process we reach the vertex  $w_m = z^*$  with  $w_{m-1} \in C_2$  and  $\{w_{m-1}, w_m\} \in E$ . Consequently each vertex in  $C_2 - \{z^*\}$  whose binary label starts with 1 is connected to  $z^*$ .

(ii) There are  $2m+1$  1s in the binary label for  $w_0$ , with  $3 \leq 2m+1 \leq n$ , and the first entry in the label for  $w_0$  is 0. Change the first entry in the binary label for  $w_0$  to 1 and the first 1 in the binary label for  $w_0$  to 0. This results in the vertex  $w_1 \in C_2$  with  $\{w_0, w_1\} \in E$ . Upon changing the second and third 1s in the binary label for  $w_1$  to 0s we obtain the vertex  $w_2 \in C_2$  with  $\{w_1, w_2\} \in E$ . Continuing this process we reach the vertex  $w_{m+1} = z^*$  with  $\{w_m, w_{m+1}\} \in E$ . This shows that each vertex in  $C_2$  whose binary label starts with 0 is also connected to  $z^*$ .

(3) We claim that the components of  $G$  are the graphs determined by  $C_1$  and  $C_2$ . Can there exist an edge  $\{x, y\} \in E$  where  $x \in C_1$ ,  $y \in C_2$ ? Here the binary label for  $x$  has an even number of 1s while the label for  $y$  has an odd number of 1s. This contradicts the definition of  $E$  - for if  $\{a, b\} \in E$  then the total number of 1s in the binary labels for  $a, b$  is even.

5. Each path from  $a$  to  $h$  must include the edge  $\{b, g\}$ . There are three paths (in  $G$ ) from  $a$  to  $b$  and three paths (in  $G$ ) from  $g$  to  $h$ . Consequently, there are nine paths from  $a$  to  $h$  in  $G$ .

There is only one path of length 3, two of length 4, three of length 5, two of length 6, and one of length 7.

6. 

c: 1	e: 1	f: 1	g: 2	h: 3
i: 4	j: 3	k: 2	l: 3	m: 3

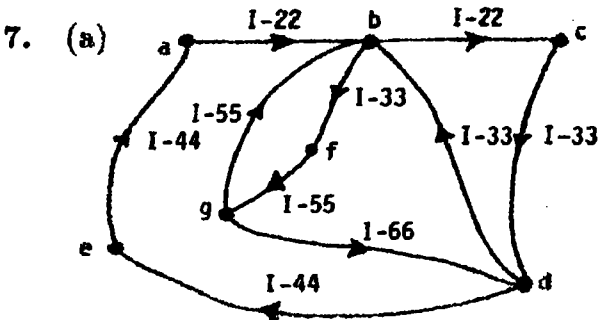

- (b)  $\{(g, d), (d, e), (e, a)\};$   
 $\{(g, b), (b, c), (c, d), (d, e), (e, a)\}.$   
(c) Two: One of  $\{(b, c), (c, d)\}$  and one of  $\{(b, f), (f, g), (g, d)\}.$   
(d) No  
(e) Yes: Travel the path  $\{(c, d), (d, e), (e, a), (a, b), (b, f), (f, g)\}.$   
(f) Yes: Travel the path  $\{(g, b), (b, f), (f, g), (g, d), (d, b), (b, c), (c, d), (d, e), (e, a), (a, b)\}.$

8. The smallest number of guards needed is 3 - e.g., at vertices  $a, g, i$ .
9. If  $\{a, b\}$  is not part of a cycle, then its removal disconnects  $a$  and  $b$  (and  $G$ ). If not, there is a path  $P$  from  $a$  to  $b$  and  $P$ , together with  $\{a, b\}$ , provides a cycle containing  $\{a, b\}$ .  
Conversely, if the removal of  $\{a, b\}$  from  $G$  disconnects  $G$  then there exist  $x, y \in V$  such that the only path  $P$  from  $x$  to  $y$  contains  $e = \{a, b\}$ . If  $e$  were part of a cycle

$C$ , then the edges in  $(P - \{e\}) \cup (C - \{e\})$  would provide a second path connecting  $x$  to  $y$ .

10. Any path.                      11. (a) Yes                      (b) No                      (c)  $n - 1$

12. (a) In a loop-free undirected graph (that is not a multigraph) the maximum number of edges is  $\binom{v}{2}$ . Hence  $e \leq \binom{v}{2} = v(v - 1)/2$ , so  $2e \leq v^2 - v$ .

(b) In a loop-free directed graph (that is not a multigraph),  $e \leq v^2 - v$ .

13. This relation is reflexive, symmetric and transitive, so it is an equivalence relation. The partition of  $V$  induced by  $\mathcal{R}$  yields the (connected) components of  $G$ .

14. (a) There are three cycles of length 4 in  $W_3$ , five cycles of length 4 in  $W_4$ , and five such cycles in  $W_5$ .

(b) Denote the consecutive cycle (rim) vertices of  $W_n$  by  $v_1, v_2, \dots, v_n$  and the additional (central) vertex by  $v_{n+1}$ .

(i) For  $n \neq 4$ , there are  $n$  cycles of length 4:

(1)  $v_1 \rightarrow v_2 \rightarrow v_3 \rightarrow v_{n+1} \rightarrow v_1$ ;

(2)  $v_2 \rightarrow v_3 \rightarrow v_4 \rightarrow v_{n+1} \rightarrow v_2$ ;

...

( $n - 1$ )  $v_{n-1} \rightarrow v_n \rightarrow v_1 \rightarrow v_{n+1} \rightarrow v_{n-1}$ ; and

( $n$ )  $v_n \rightarrow v_1 \rightarrow v_2 \rightarrow v_{n+1} \rightarrow v_n$ .

When  $n = 4$  the vertices  $v_1, v_2, v_3, v_4$  provide a cycle. The other four cycles of length 4 consist of vertex  $v_5$  and three of the four vertices  $v_1, v_2, v_3, v_4$ .

(ii) There are  $n + 1$  cycles of length  $n$  in  $W_n$ :

(1)  $v_1 \rightarrow v_2 \rightarrow v_3 \rightarrow \dots \rightarrow v_{n-1} \rightarrow v_n \rightarrow v_1$ ;

(2)  $v_1 \rightarrow v_{n+1} \rightarrow v_3 \rightarrow v_4 \rightarrow \dots \rightarrow v_{n-1} \rightarrow v_n \rightarrow v_1$ ;

(3)  $v_2 \rightarrow v_{n+1} \rightarrow v_4 \rightarrow v_5 \rightarrow \dots \rightarrow v_{n-1} \rightarrow v_n \rightarrow v_1 \rightarrow v_2$ ;

...

( $n$ )  $v_{n-1} \rightarrow v_{n+1} \rightarrow v_1 \rightarrow v_2 \rightarrow \dots \rightarrow v_{n-3} \rightarrow v_{n-2} \rightarrow v_{n-1}$ ; and

( $n + 1$ )  $v_n \rightarrow v_{n+1} \rightarrow v_2 \rightarrow v_3 \rightarrow \dots \rightarrow v_{n-3} \rightarrow v_{n-1} \rightarrow v_n$ .

15. For  $n \geq 1$ , let  $a_n$  count the number of closed  $v - v$  walks of length  $n$  (where, in this case, we allow such a walk to contain or consist of one or more loops). Here  $a_1 = 1$  and  $a_2 = 2$ . For  $n \geq 3$  there are  $a_{n-1}$   $v - v$  walks where the last edge is the loop  $\{v, v\}$  and  $a_{n-2}$   $v - v$  walks where the last two edges are both  $\{v, w\}$ . Since these two cases are exhaustive and have nothing in common we have  $a_n = a_{n-1} + a_{n-2}$ ,  $n \geq 3$ ,  $a_1 = 1$ ,  $a_2 = 2$ .

We find that  $a_n = F_{n+1}$ , the  $(n + 1)$ st Fibonacci number.

16. a) There are two other unit-interval graphs for three unit intervals.

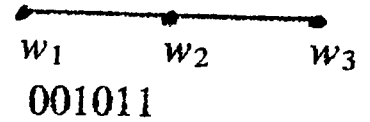
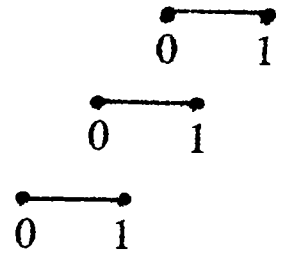
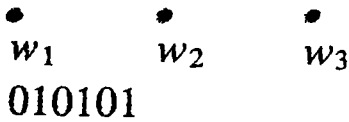
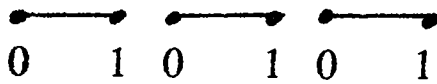

b) For four unit intervals there are 14 unit-interval graphs.

c) For  $n \geq 1$ , there are  $b_n = \frac{1}{n+1} \binom{2n}{n}$  unit-interval graphs for  $n$  unit intervals. Here  $b_n$  is the  $n$ th Catalan number. The binary representations set up a one-to-one correspondence with the situations in Example 1.40 – in particular, change 0 to 1 and 1 to 0 in part (b) of Example 1.40 to obtain the binary representations of the 14 unit-interval graphs on four unit intervals.

### Section 11.2

1. (a) Three: (1)  $\{b, a\}, \{a, c\}, \{c, d\}, \{d, a\}$   
 (2)  $\{f, c\}, \{c, a\}, \{a, d\}, \{d, c\}$   
 (3)  $\{i, d\}, \{d, c\}, \{c, a\}, \{a, d\}$

(b)  $G_1$  is the subgraph induced by  $U = \{a, b, d, f, g, h, i, j\}$   
 $G_1 = G - \{c\}$

(c)  $G_2$  is the subgraph induced by  $W = \{b, c, d, f, g, i, j\}$   
 $G_2 = G - \{a, h\}$

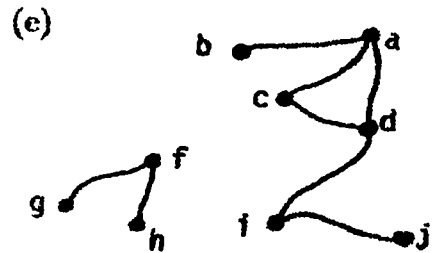
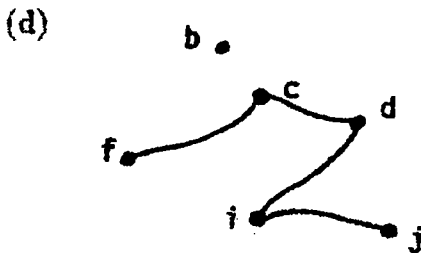

2. (a)  $G_1$  is not an induced subgraph of  $G$  if there exists an edge  $\{a, b\}$  in  $E$  such that

$a, b \in V$ , but  $\{a, b\} \notin E_1$ .

(b) Let  $e = \{a, d\}$ . Then  $G - e$  is a subgraph of  $G$  but it is not an induced subgraph.

3. (a) There are  $2^9 = 512$  spanning subgraphs.
- (b) Four of the spanning subgraphs in part (a) are connected.
- (c)  $2^6$
4. There is only one – the graph  $G$  itself.
5.  $G$  is (or is isomorphic to) the complete graph  $K_n$ , where  $n = |V|$ .
6. There are 11 loop-free nonisomorphic undirected graphs with four vertices.

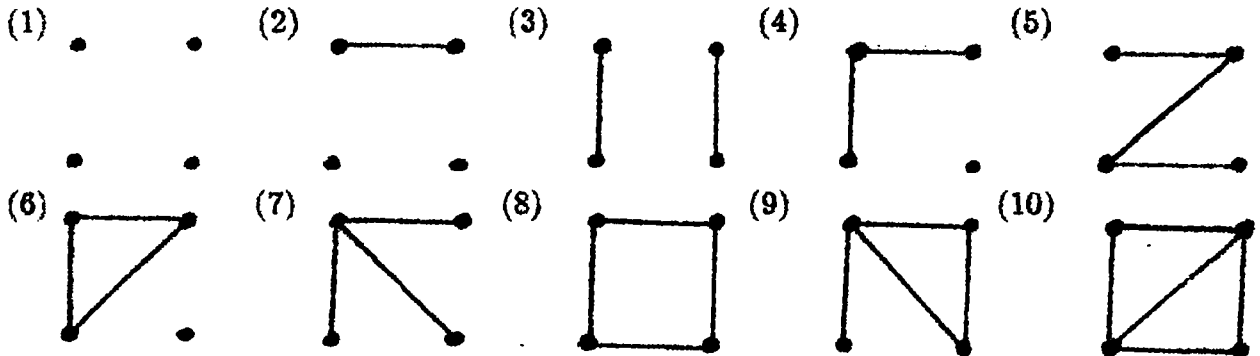

Six of these graphs are connected.

7. (a) (b) No solution.

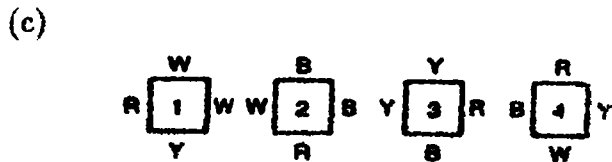
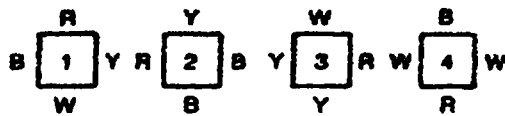

8. (a) There are  $(1/2)(7)(6)(5)(4)(3) = 1260$  paths of length 4 in  $K_7$ .
- (b) The number of paths of length  $m$  in  $K_n$ , for  $0 < m < n$ , is  $(1/2)(n)(n-1)(n-2)\cdots(n-m)$ .
9. (a) Each graph has four vertices that are incident with three edges. In the second graph

these vertices  $(w,x,y,z)$  form a cycle. This is not so for the corresponding vertices  $(a,b,g,h)$  in the first graph. Hence the graphs are *not* isomorphic.

(b) In the first graph the vertex  $d$  is incident with four edges. No vertex in the second graph has this property, so the graphs are *not* isomorphic.

10. If  $G$  has  $v$  vertices and  $e$  edges, then by the definition of  $\bar{G}$ , there are  $\binom{v}{2} - e$  edges in  $\bar{G}$  since there are  $\binom{v}{2}$  edges in  $K_v$ .

11. (a) If  $G_1 = (V_1, E_1)$  and  $G_2 = (V_2, E_2)$  are isomorphic, then there is a function  $f : V_1 \rightarrow V_2$  that is one-to-one and onto and preserves adjacencies. If  $x, y \in V_1$  and  $\{x, y\} \notin E_1$ , then  $\{f(x), f(y)\} \notin E_2$ . Hence the same function  $f$  preserves adjacencies for  $\bar{G}_1, \bar{G}_2$  and can be used to define an isomorphism for  $\bar{G}_1, \bar{G}_2$ . The converse follows in a similar way.

(b) They are not isomorphic. The complement of the graph containing vertex  $a$  is a cycle of length 8. The complement of the other graph is the disjoint union of two cycles of length 4.

12. (a) Let  $e_1$  be the number of edges in  $G$  and  $e_2$  the number in  $\bar{G}$ . For any (loop-free) undirected graph  $G$ ,  $e_1 + e_2 = \binom{n}{2}$ , the number of edges in  $K_n$ . Since  $G$  is self-complementary,  $e_1 = e_2$ , so  $e_1 = (1/2)\binom{n}{2} = n(n-1)/4$ .

(b) Four vertices:



Five vertices:

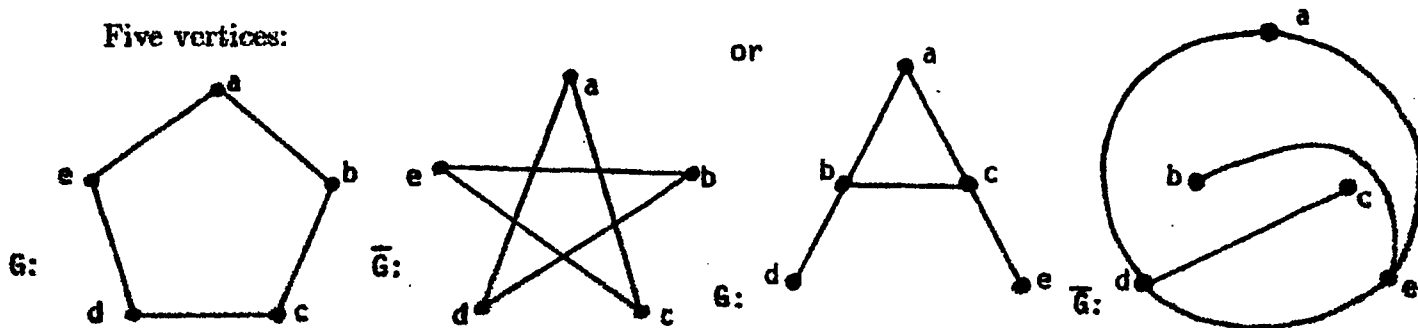

(c) From part (a),  $4|n(n-1)$ . One of  $n$  and  $n-1$  is even and the other factor odd. If  $n$  is even, then  $4|n$  and  $n = 4k$ , for some  $k \in \mathbb{Z}^+$ . If  $n-1$  is even, then  $4|(n-1)$  and  $n-1 = 4k$ , or  $n = 4k + 1$ , for some  $k \in \mathbb{Z}^+$ .

13. If  $G$  is the cycle with edges  $\{a, b\}, \{b, c\}, \{c, d\}, \{d, e\}$  and  $\{e, a\}$ , then  $\overline{G}$  is the cycle with edges  $\{a, c\}, \{c, e\}, \{e, b\}, \{b, d\}, \{d, a\}$ . Hence,  $G$  and  $\overline{G}$  are isomorphic. Conversely, if  $G$  is a cycle on  $n$  vertices and  $G, \overline{G}$  are isomorphic, then  $n = (1/2)\binom{n}{2}$ , or  $n = (1/4)(n)(n-1)$ , and  $n = 5$ .

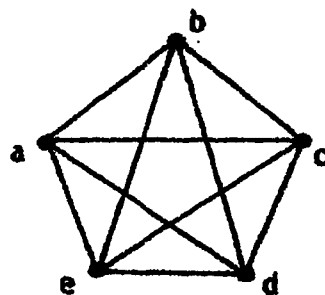

14. (a) All of the examples in Exercise 12 above satisfy these conditions.  
 (b) Since  $G$  is not connected, there exist vertices  $x, y$  and no path in  $G$  connecting these vertices. Hence  $\{x, y\}$  is an edge in  $\overline{G}$ . For each vertex  $a$  in  $G$ ,  $a \neq x, y$ , either  $\{a, x\}$  or  $\{a, y\}$  is in  $\overline{G}$ . If not, both  $\{a, x\}, \{a, y\}$  are in  $G$  and  $\{x, a\}, \{a, y\}$  provide a path in  $G$  connecting  $x$  and  $y$ . Let  $b, c \in V$ . If  $\{b, x\}, \{c, x\}$  are both in  $\overline{G}$ , there is a path connecting  $b, c$ : namely,  $\{b, x\}, \{x, c\}$ . The same is true if  $\{b, y\}, \{c, y\}$  both occur in  $\overline{G}$ . If neither of these situations occurs we have  $\{b, x\}, \{c, y\}$  in  $\overline{G}$  (or  $\{b, y\}, \{c, x\}$ ) and then the edges  $\{b, x\}, \{x, y\}, \{y, c\}$  provide a path connecting  $b$  and  $c$ .
15. (a) Here  $f$  must also maintain directions. So if  $(a, b) \in E_1$ , then  $(f(a), f(b)) \in E_2$ .  
 (b) They are not isomorphic. Consider vertex  $a$  in the first graph. It is incident to one vertex and incident from two other vertices. No vertex in the other graph has this property.

16. (a)  $\binom{6}{3}(2^3) = \binom{6}{3}(2^{\binom{3}{2}})$       (b)  $\binom{6}{4}(2^{\binom{4}{2}})$   
 (c)  $\sum_{k=1}^6 \binom{6}{k}(2^{\binom{k}{2}})$       (d)  $\sum_{k=1}^n \binom{n}{k}(2^{\binom{k}{2}})$

17. There are two cases to consider:

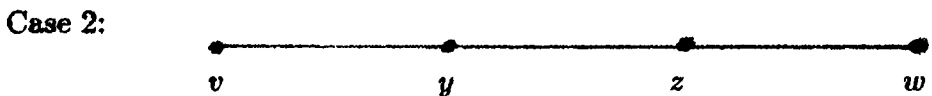

Here there are  $n - 2$  choices for  $y$  - namely, any vertex other than  $v, w$  - and there are  $n - 2$  choices for  $z$  - namely, any vertex other than  $w$  or the vertex selected for  $z$ .

Consequently, there are  $(n - 1) + (n - 2)^2 = n^2 - 3n + 3$  walks of length 3 from  $v$  to  $w$ .

### Section 11.3

1. (a)  $|V| = 6$   
 (b)  $|V| = 1$  or  $2$  or  $3$  or  $5$  or  $6$  or  $10$  or  $15$  or  $30$ . [In the first four cases  $G$  must be a multigraph; when  $|V| = 30$ ,  $G$  is disconnected.]

(c)  $|V| = 6$

2.  $2|E| = 2(17) = 34 = \sum_{v \in V} \deg(v) \geq 3|V|$ , so the maximum value of  $|V|$  is 11.
3. Since  $38 = 2|E| = \sum_{v \in V} \deg(v) \geq 4|V|$ , the largest possible value for  $|V|$  is 9. We can have (i) seven vertices of degree 4 and two of degree 5; or (ii) eight vertices of degree 4 and one of degree 6. The graph in part (a) of the figure is an example for case (i); an example for case (ii) is provided in part (b) of the figure.

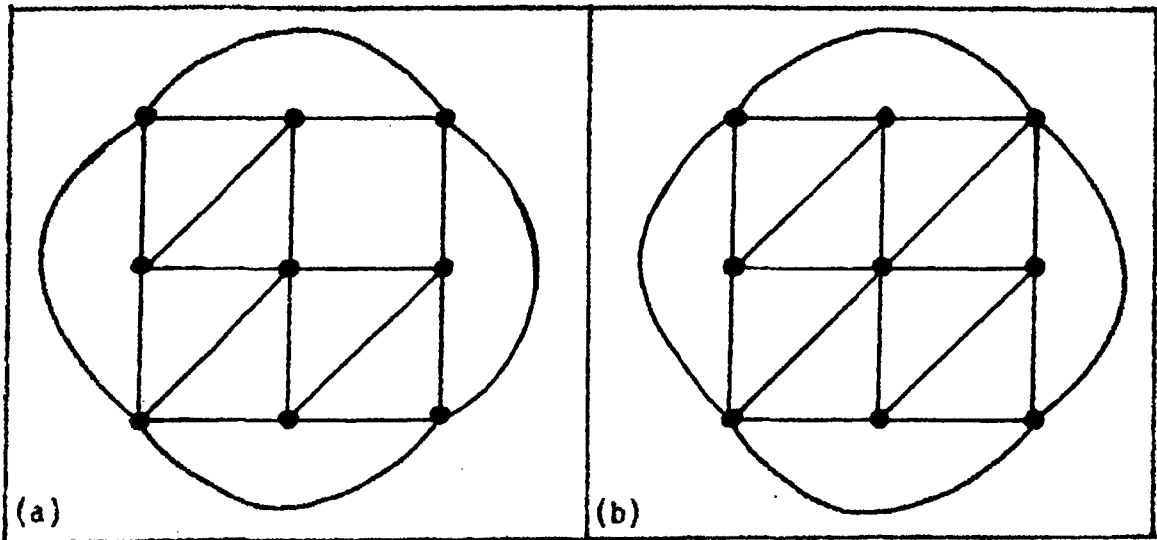

4. a) We must note here that  $G$  need *not* be connected. Up to isomorphism  $G$  is either a cycle on six vertices or (a disjoint union of) two cycles, each on three vertices.
- b) Here  $G$  is either a cycle on seven vertices or (a disjoint union of) two cycles — one on three vertices and the other on four.
- c) For such a graph  $G_1$ ,  $\overline{G_1}$  is one of the graphs in part (a). Hence there are two such graphs  $G_1$ .
- d) Here  $\overline{G_1}$  is one of the graphs in part (b). There are two such graphs  $G_1$  (up to isomorphism).
- e) Let  $G_1 = (V_1, E_1)$  be a loop-free undirected  $(n - 3)$ -regular graph with  $|V| = n$ . Up to isomorphism the number of such graphs  $G_1$  is the number of partitions of  $n$  into summands that exceed 2.

5. (a)  $|V_1| = 8 = |V_2|$ ;  $|E_1| = 14 = |E_2|$ .
- (b) For  $V_1$  we find that  $\deg(a) = 3$ ,  $\deg(b) = 4$ ,  $\deg(c) = 4$ ,  $\deg(d) = 3$ ,  $\deg(e) = 3$ ,  $\deg(f) = 4$ ,  $\deg(g) = 4$ , and  $\deg(h) = 3$ . For  $V_2$  we have  $\deg(s) = 3$ ,  $\deg(t) = 4$ ,  $\deg(u) = 4$ ,  $\deg(v) = 3$ ,  $\deg(w) = 4$ ,  $\deg(x) = 3$ ,  $\deg(y) = 3$ , and  $\deg(z) = 4$ . Hence each of the two graphs has four vertices of degree 3 and four of degree 4.
- (c) Despite the results in parts (a) and (b) the graphs  $G_1$  and  $G_2$  are *not* isomorphic.

In the graph  $G_2$  the four vertices of degree 4 — namely,  $t, u, w$ , and  $z$  — are on a cycle of length 4. For the graph  $G_1$  the vertices  $b, c, f$ , and  $g$  — each of degree 4 — do not lie on a cycle of length 4.

A second way to observe that  $G_1$  and  $G_2$  are not isomorphic is to consider once again the vertices of degree 4 in each graph. In  $G_1$  these vertices induce a disconnected subgraph consisting of the two edges  $\{b, c\}$  and  $\{f, g\}$ . The four vertices of degree 4 in graph  $G_2$  induce a connected subgraph that has five edges — every possible edge except  $\{u, z\}$ .

6.

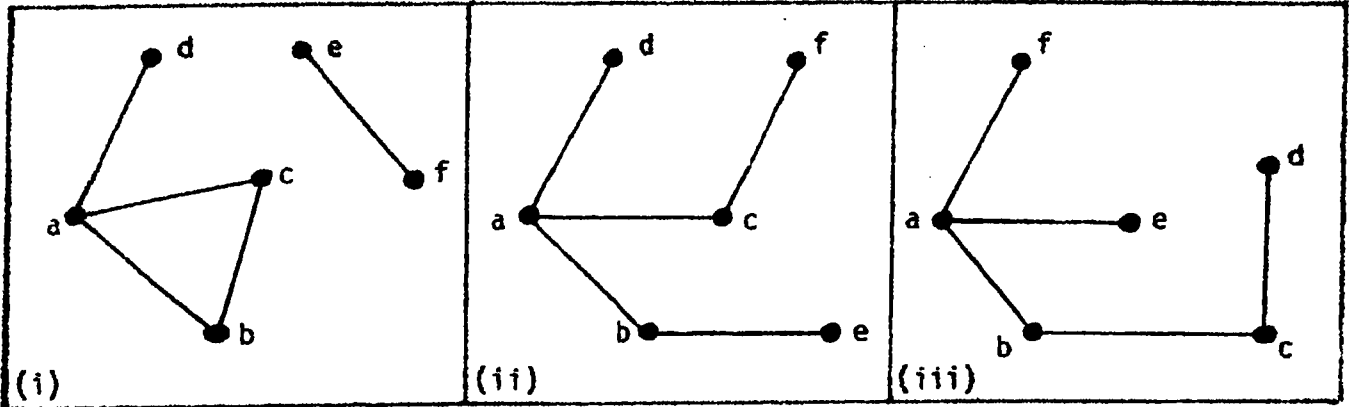

7. a) 19      b)  $\sum_{i=1}^n \binom{d_i}{2}$  [Note: No assumption about connectedness is made here.]

8. a) There are  $8 \cdot 2^7 = 1024$  edges in  $Q_8$ .  
 b) The maximum distance between pairs of vertices is 8. For example, the distance between 00000000 and 11111111 is 8.  
 c) A longest path in  $Q_8$  contains all of the vertices in  $Q_8$ . Such a path has length  $2^8 - 1 = 255$ .

9. a)  $n \cdot 2^{n-1} = 524,288 \Rightarrow n = 16$   
 b)  $n \cdot 2^{n-1} = 4,980,736 \Rightarrow n = 19$ , so there are  $2^{19} = 524,288$  vertices in this hypercube.

10. The typical path of length 2 uses two edges of the form  $\{a, b\}, \{b, c\}$ . We can select the vertex  $b$  as any vertex of  $Q_n$ , so there are  $2^n$  choices for  $b$ . The vertex  $b$  (labeled by a binary  $n$ -tuple) is adjacent to  $n$  other vertices in  $Q_n$  and we can choose two of these in  $\binom{n}{2}$  ways. Consequently, there are  $\binom{n}{2} 2^n$  paths of length 2 in  $Q_n$ .

11. The number of edges in  $K_n$  is  $\binom{n}{2} = n(n-1)/2$ . If the edges of  $K_n$  can be partitioned into such cycles of length 4, then 4 divides  $\binom{n}{2}$  and  $\binom{n}{2} = 4t$  for some  $t \in \mathbb{Z}^+$ . For each vertex  $v$  that appears in a cycle, there are two edges (of  $K_n$ ) incident to  $v$ . Consequently, each vertex  $v$  of  $K_n$  has even degree, so  $n$  is even. Therefore,  $n-1$  is odd and as  $4t = \binom{n}{2} = n(n-1)/2$ , it follows that  $8t = n(n-1)$ . So 8 divides  $n(n-1)$ , and since  $n$  is even, it follows (from the Fundamental Theorem of Arithmetic) that 8 divides  $n-1$ . Hence  $n-1 = 8k$ , or  $n = 8k + 1$ , for some  $k \in \mathbb{Z}^+$ .

12. a) Let  $v \in V$ . Then  $vRv$  since  $v$  and itself have the same bit in position  $k$  and the same

bit in position  $\ell$  — hence,  $\mathcal{R}$  is reflexive. If  $v, w \in V$  and  $v\mathcal{R}w$  then  $v, w$  have the same bit in position  $k$  and the same bit in position  $\ell$ . Hence  $w, v$  have the same bit in position  $k$  and the same bit in position  $\ell$ . So  $w\mathcal{R}v$  and  $\mathcal{R}$  is symmetric. Finally, suppose that  $v, w, x \in V$  with  $v\mathcal{R}w$  and  $w\mathcal{R}x$ . Then  $v, w$  have the same bit in position  $k$  and the same bit in position  $\ell$ , and  $w, x$  have the same bit in position  $k$  and the same bit in position  $\ell$ . Consequently,  $v, x$  have the same bit in position  $k$  and the same bit in position  $\ell$ , so  $v\mathcal{R}x$  — and  $\mathcal{R}$  is transitive. In so much as  $\mathcal{R}$  is reflexive, symmetric and transitive, it follows that  $\mathcal{R}$  is an equivalence relation.

There are four blocks for (the partition induced by) this equivalence relation. Each block contains  $2^{n-2}$  vertices; the vertices in each such block induce a subgraph isomorphic to  $Q_{n-2}$ .

(b) For  $n \geq 1$  let  $V$  denote the vertices in  $Q_n$ . For  $1 \leq k_1 < k_2 < \dots < k_t \leq n$  and  $w, x \in V$  define the relation  $\mathcal{R}$  on  $V$  by  $w\mathcal{R}x$  if  $w, x$  have the same bit in position  $k_1$ , the same bit in position  $k_2, \dots$ , and the same bit in position  $k_t$ . Then  $\mathcal{R}$  is an equivalence relation for  $V$  and it partitions  $V$  into  $2^t$  blocks. Each block contains  $2^{n-t}$  vertices and the vertices in each such block induce a subgraph of  $Q_n$  isomorphic to  $Q_{n-t}$ .

13.  $\delta|V| \leq \sum_{v \in V} \deg(v) \leq \Delta|V|$ . Since  $2|E| = \sum_{v \in V} \deg(v)$ , it follows that  $\delta|V| \leq 2|E| \leq \Delta|V|$  so  $\delta \leq 2(e/n) \leq \Delta$ .

14. (a)  $f^{-1}$  is one-to-one and onto. Let  $x, y \in V'$  and  $\{x, y\} \in E'$ . Then  $f$  one-to-one and onto  $\implies$  there exist unique  $a, b \in V$  with  $f(a) = x$ ,  $f(b) = y$ . If  $\{a, b\} \notin E$ , then  $\{f(a), f(b)\} \notin E'$ .

(b) If  $\deg(a) = n$ , then there exist  $x_1, x_2, \dots, x_n \in V$  and  $\{a, x_i\} \in E, 1 \leq i \leq n$ . Hence, the edge  $\{f(a), f(x_i)\} \in E'$  for all  $1 \leq i \leq n$ , so  $\deg(f(a)) \geq n$ . If  $\deg(f(a)) > n$ , let  $y \in V'$  such that  $y \neq f(x_i)$  for all  $1 \leq i \leq n$ , and  $y = f(x)$ . Since  $f^{-1}$  is an isomorphism by part (a),  $\{a, x\} \in E$  and  $\deg(a) > n$ . Hence  $\deg f(a) = n$ .

15. Proof: Start with a cycle  $v_1 \rightarrow v_2 \rightarrow v_3 \rightarrow \dots \rightarrow v_{2k-1} \rightarrow v_{2k} \rightarrow v_1$ . Then draw the  $k$  edges  $\{v_1, v_{k+1}\}, \{v_2, v_{k+2}\}, \dots, \{v_i, v_{i+k}\}, \dots, \{v_k, v_{2k}\}$ . The resulting graph has  $2k$  vertices each of degree 3.

16. Proof: (By the Alternative Form of the Principle of Mathematical Induction)

The result is true for  $n = 1$  (for the complete graph  $K_2$ ) and for  $n = 2$  (for the path on four vertices). So let us assume the result for all  $1 \leq n \leq k$ , and consider the case for  $n = k + 1$ . Let  $G'$  be a graph for  $n = k - 1$ , and add to this graph two isolated vertices  $x$  and  $y$ . Now introduce two other vertices  $a$  and  $b$  and the edge  $\{a, b\}$ . Draw an edge between  $a$  and  $x$ , and between  $a$  and  $k - 1$  of the vertices (one of each of the degrees  $1, 2, \dots, k - 1$ ) in  $G'$ . Now draw an edge between  $b$  and  $y$ , and between  $b$  and the other  $k - 1$  vertices in  $G'$  (the vertices not adjacent to vertex  $a$ ). The resulting graph has  $2(k + 1)$  vertices where exactly two vertices have degree  $i$  for all  $1 \leq i \leq k + 1$ .

Consequently, the result follows for all  $n \in \mathbb{Z}^+$  by the Alternative Form of the Principle of

Mathematical Induction.

17. (Corollary 11.1) Let  $V = V_1 \cup V_2$  where  $V_1$  ( $V_2$ ) contains all vertices of odd (even) degree. Then  $2|E| - \sum_{v \in V_2} \deg(v) = \sum_{v \in V_1} \deg(v)$  is an even integer. For  $|V_1|$  odd,  $\sum_{v \in V_1} \deg(v)$  is odd.

(Corollary 11.2) For the converse let  $G = (V, E)$  have an Euler trail with  $a, b$  as the starting and terminating vertices, respectively. Add the edge  $\{a, b\}$  to  $G$  to form the graph  $G' = (V, E')$ , where  $G'$  has an Euler circuit. Hence  $G'$  is connected and each vertex has even degree. Removing edge  $\{a, b\}$  the vertices in  $G$  will have the same even degree except for  $a, b$ .  $\deg_G(a) = \deg_{G'}(a) - 1, \deg_G(b) = \deg_{G'}(b) - 1$ , so the vertices  $a, b$  have odd degree in  $G$ . Also, since the edges in  $G$  form an Euler trail,  $G$  is connected.

18. Select  $v_1, v_2 \in V$  where  $\{v_1, v_2\} \in E$ . Such an edge must exist since  $V \neq \emptyset$  and  $\deg(v) \geq k \geq 1$  for all  $v \in V$ . If  $k = 1$  the result follows. If  $k > 1$ , suppose that we have selected  $v_1, v_2, \dots, v_k \in V$  with  $\{v_1, v_2\}, \{v_2, v_3\}, \dots, \{v_{k-1}, v_k\} \in E$ . Since  $\deg(v_k) \geq k$ , there exists  $v_{k+1} \in V$  where  $v_{k+1} \neq v_i$  for  $1 \leq i \leq k-1$ , and  $\{v_k, v_{k+1}\} \in E$ . Then  $\{v_1, v_2\}, \{v_2, v_3\}, \dots, \{v_{k-1}, v_k\}, \{v_k, v_{k+1}\}$  provides a path of length  $k$ .
19. (a) Let  $a, b, c, x, y \in V$  with  $\deg(a) = \deg(b) = \deg(c) = 1, \deg(x) = 5$ , and  $\deg(y) = 7$ . Since  $\deg(y) = 7, y$  is adjacent to all of the other (seven) vertices in  $V$ . Therefore vertex  $x$  is not adjacent to any of the vertices  $a, b$ , and  $c$ . Since  $x$  cannot be adjacent to itself, unless we have loops, it follows that  $\deg(x) \leq 4$ , and we cannot draw a graph for the given conditions.

(b)

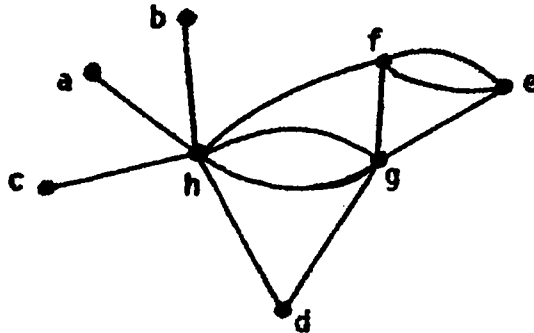

20. (a)  $a \rightarrow b \rightarrow c \rightarrow g \rightarrow k \rightarrow j \rightarrow g \rightarrow b \rightarrow f \rightarrow j \rightarrow i \rightarrow f \rightarrow e \rightarrow i \rightarrow h \rightarrow d \rightarrow e \rightarrow b \rightarrow d \rightarrow a$
- (b)  $d \rightarrow a \rightarrow b \rightarrow d \rightarrow h \rightarrow i \rightarrow e \rightarrow f \rightarrow i \rightarrow j \rightarrow f \rightarrow b \rightarrow c \rightarrow g \rightarrow k \rightarrow j \rightarrow g \rightarrow b \rightarrow e$

21.  $n$  odd:  $n = 2$

22. 1; Any single bridge.

23. Yes. Model the situation with a graph where there is a vertex for each room and the surrounding corridor. Draw an edge between two vertices if there is a door common to both rooms, or a room and the surrounding corridor. The resulting multigraph is connected with every vertex of even degree.

24. We find that  $\sum_{v \in V} \text{id}(v) = e = \sum_{v \in V} \text{od}(v)$ .
25. (a) (i) Let the vertices of  $K_6$  be  $v_1, v_2, v_3, v_4, v_5, v_6$ , where  $\text{deg}(v_i) = 5$  for all  $1 \leq i \leq 6$ . Consider the subgraph  $S$  of  $K_6$  obtained (from  $K_6$ ) by deleting the edges  $\{v_2, v_5\}$  and  $\{v_3, v_6\}$ . Then  $S$  is connected with  $\text{deg}(v_1) = \text{deg}(v_4) = 5$ , and  $\text{deg}(v_i) = 4$  for  $i \in \{2, 3, 5, 6\}$ . Hence  $S$  has an Euler trail that starts at  $v_1$  (or  $v_4$ ) and terminates at  $v_4$  (or  $v_1$ ). This Euler trail in  $S$  is then a trail of maximum length in  $K_6$ , and its length is  $\binom{6}{2} - (1/2)[6 - 2] = 15 - 2 = 13$ .
- (ii)  $\binom{8}{2} - (1/2)[8 - 2] = 28 - 3 = 25$
- (iii)  $\binom{10}{2} - (1/2)[10 - 2] = 45 - 4 = 41$
- (iv)  $\binom{2n}{2} - (1/2)[2n - 2] = n(2n - 1) - (n - 1) = 2n^2 - 2n + 1$ .
- (b) (i) Label the vertices of  $K_6$  as in section (i) of part (a) above. Now consider the subgraph  $T$  of  $K_6$  obtained (from  $K_6$ ) by deleting the edges  $\{v_1, v_4\}$ ,  $\{v_2, v_5\}$ , and  $\{v_3, v_6\}$ . Then  $T$  is connected with  $\text{deg}(v_i) = 4$  for all  $1 \leq i \leq n$ . Hence  $T$  has an Euler circuit and this Euler circuit for  $T$  is then a circuit of maximum length in  $K_6$ . The length of the circuit is  $\binom{6}{2} - (1/2)(6) = 15 - 3 = 12$ .
- (ii)  $\binom{8}{2} - (1/2)(8) = 28 - 4 = 24$
- (iii)  $\binom{10}{2} - (1/2)(10) = 45 - 5 = 40$
- (iv)  $\binom{2n}{2} - (1/2)(2n) = n(2n - 1) - n = 2n^2 - 2n = 2n(n - 1)$ .
26. (a) If  $G = (V, E)$  has a directed Euler circuit, then for all  $x, y \in V$  there is a directed trail from  $x$  to  $y$  (that part of the directed Euler circuit from  $x$  to  $y$ ). This results in a directed path from  $x$  to  $y$ , as well as one from  $y$  to  $x$ . Hence  $G$  is connected (in fact,  $G$  is strongly connected as defined in part (b) of this exercise). Let  $s$  be the starting vertex (and terminal vertex) of the directed Euler circuit. For every  $v \in V, v \neq s$ , each time the circuit comes upon vertex  $v$  it must also leave the vertex, so  $\text{od}(v) = \text{id}(v)$ . In the case of  $s$  the last edge of the circuit is different from the first edge and  $\text{od}(s) = \text{id}(s)$ .

Conversely, if  $G$  satisfies the stated conditions, we shall prove by induction on  $|E|$  that  $G$  has a directed Euler circuit. For  $|E| = 1$  the result is true (and the graph consists of a (directed) loop on one vertex). We assume the result for all such graphs with  $|E|$  edges where  $1 \leq |E| < n$ . Now consider a directed graph  $G = (V, E)$  where  $G$  satisfies the given conditions and  $|E| = n$ . Let  $a \in V$ . There exists a circuit in  $G$  that contains  $a$ . If the loop  $(a, a) \notin E$ , then there is an edge  $(a, b) \in E$  for  $b \neq a$ . If not,  $a$  is isolated and this contradicts  $G$  being connected. If  $(b, a) \in E$  we have the circuit  $\{(a, b), (b, a)\}$  containing  $a$ . If  $(b, a) \notin E$ , then there is an edge of the form  $(b, c), c \neq b, c \neq a$ , because  $\text{od}(b) = \text{id}(b)$ . Continuing this process, since  $\text{od}(a) = \text{id}(a)$  and  $G$  is finite, we obtain a directed circuit  $C$  containing  $a$ . If  $C = G$  we are finished. If not, remove the edges of  $C$  from  $G$ , along with any vertex that becomes isolated. The resulting subgraph  $H = (V_1, E_1)$  is such that (in  $H$ )  $\text{od}(v) = \text{id}(v)$  for all  $v \in V_1$ . However,  $H$  is not

necessarily connected. But each component of  $H$  is connected with  $\text{od}(v) = \text{id}(v)$  for each vertex in a component. Consequently, by the induction hypothesis, each component of  $H$  has a directed Euler circuit, and each component has a vertex on the circuit  $C$  (from above). Hence, starting at vertex  $a$  we travel on  $C$  until we encounter a vertex  $v_1$  on the directed Euler circuit of the component  $C_1$  of  $H$ . Traversing  $C_1$  we return to  $v_1$  and continue on  $C$  to vertex  $v_2$  on component  $C_2$  of  $H$ . Continuing the process, with  $G$  finite we obtain a directed Euler circuit for  $G$ .

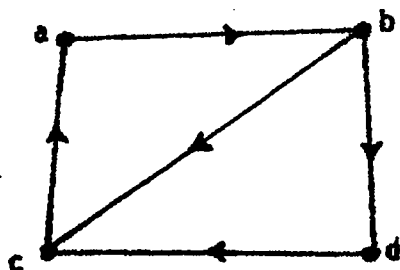

(b) If  $G = (V, E)$  is a directed graph with a directed Euler circuit then for all  $x, y \in V, x \neq y$ , there is a directed path from  $x$  to  $y$ , and one from  $y$  to  $x$ , so the graph is strongly connected. The converse, however, is false. The directed graph shown here is strongly connected. However, since  $\text{od}(b) \neq \text{id}(b)$  the graph does not have a directed Euler circuit.

27. From Exercise 24 we see that  $\sum_{v \in V} [\text{od}(v) - \text{id}(v)] = 0$ . For each  $v \in V, \text{od}(v) + \text{id}(v) = n - 1$ , so  $0 = (n - 1) \cdot 0 = \sum_{v \in V} (n - 1)[\text{od}(v) - \text{id}(v)] = \sum_{v \in V} [\text{od}(v) + \text{id}(v)][\text{od}(v) - \text{id}(v)] = \sum_{v \in V} [(\text{od}(v))^2 - (\text{id}(v))^2]$ , and the result follows.

28. Let  $G$  be a directed graph satisfying the three conditions. Add the edge  $(x, y)$ . Then by part (a) of Exercise 26 the resulting graph has a directed Euler circuit  $C$ . Removing  $(x, y)$  from  $C$  yields a directed Euler trail for the given graph  $G$ . (This trail starts at  $y$  and terminates at  $x$ .) In a similar manner we find that if a directed graph  $G$  has a directed Euler trail then it satisfies the three conditions.

29. (a) and (b)

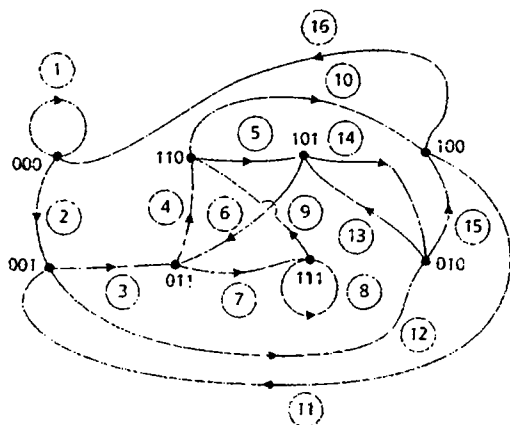

(c)

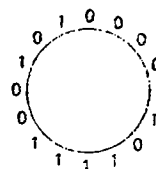

30. 3; 3

31. Let  $|V| = n \geq 2$ . Since  $G$  is loop-free and connected, for all  $x \in V$  we have  $1 \leq \text{deg}(x) \leq n - 1$ . Apply the pigeonhole principle with the  $n$  vertices as the pigeons and the  $n - 1$  possible degrees as the pigeonholes.

32. (a)

$$A = \begin{matrix} & \begin{matrix} v_1 & v_2 & v_3 & v_4 & v_5 \end{matrix} \\ \begin{matrix} v_1 \\ v_2 \\ v_3 \\ v_4 \\ v_5 \end{matrix} & \begin{bmatrix} 0 & 1 & 1 & 0 & 1 \\ 1 & 0 & 1 & 1 & 1 \\ 1 & 1 & 1 & 1 & 1 \\ 0 & 1 & 1 & 0 & 1 \\ 1 & 1 & 1 & 1 & 1 \end{bmatrix} \end{matrix}$$

$$I = \begin{matrix} & \begin{matrix} e_1 & e_2 & e_3 & e_4 & e_5 & e_6 & e_7 & e_8 & e_9 & e_{10} & e_{11} \end{matrix} \\ \begin{matrix} v_1 \\ v_2 \\ v_3 \\ v_4 \\ v_5 \end{matrix} & \begin{bmatrix} 1 & 1 & 1 & 0 & 0 & 0 & 0 & 0 & 0 & 0 & 0 \\ 0 & 0 & 1 & 1 & 1 & 1 & 0 & 0 & 0 & 0 & 0 \\ 1 & 0 & 0 & 0 & 1 & 0 & 0 & 1 & 0 & 1 & 1 \\ 0 & 0 & 0 & 0 & 0 & 1 & 0 & 1 & 1 & 0 & 0 \\ 0 & 1 & 0 & 1 & 0 & 0 & 1 & 0 & 1 & 1 & 0 \end{bmatrix} \end{matrix}$$

(b) If there is a walk of length two between  $v_i$  and  $v_j$ , denote this by  $\{v_i, v_k\}, \{v_k, v_j\}$ . Then  $a_{ik} = a_{kj} = 1$  in  $A$  and the  $(i, j)$ -entry in  $A^2$  is 1. Conversely, if the  $(i, j)$ -entry of  $A^2$  is 1 then there is at least one value of  $k$ ,  $1 \leq k \leq n$ , such that  $a_{ik} = a_{kj} = 1$ , and this indicates the existence of a walk  $\{v_i, v_k\}, \{v_k, v_j\}$  between the  $i$ th and  $j$ th vertices of  $V$ .

(c) For all  $1 \leq i, j \leq n$ , the  $(i, j)$ -entry of  $A^2$  counts the number of distinct walks of length two between the  $i$ th and  $j$ th vertices of  $V$ .

(d) For  $v$  at the top of the column, the column sum is the degree of  $v$ , if there is no loop at  $v$ . Otherwise,  $\deg(v) = [(\text{column sum for } v) - 1] + 2$  (number of loops at  $v$ ).

(e) For each column of  $I$  the column sum is 1 for a loop and 2 for an edge that is not a loop.

33. (a) Label the rows and columns of the first matrix with  $a, b, c$ . Then the graph for this adjacency matrix is a path of two edges where  $\deg(a) = \deg(b) = 1$  and  $\deg(c) = 2$ .

Now label the rows and columns of the second matrix with  $x, y, z$ . The graph for this adjacency matrix is a path of two edges where  $\deg(y) = \deg(z) = 1$  and  $\deg(x) = 2$ .

Define  $f: \{a, b, c\} \rightarrow \{x, y, z\}$  by  $f(a) = y$ ,  $f(b) = z$ ,  $f(c) = x$ . This function provides an isomorphism for these two graphs.

Alternatively, if we start with the first matrix and interchange rows 1 and 3 and then interchange columns 1 and 3 (on the resulting matrix), we obtain the second matrix. This also shows us that the graphs (corresponding to these adjacency matrices) are isomorphic.

(b) Yes

(c) No

34. (a) Here each graph is a cycle on three vertices - so they are isomorphic.

(b) The graphs here are not isomorphic. The graph for the first incidence matrix is a cycle of length 3 with the fourth (remaining) edge incident with one of the cycle vertices. The second graph is a cycle on four vertices.

(c) Yes

35. No. Let each person represent a vertex for a graph. If  $v, w$  represent two of these people, draw the edge  $\{v, w\}$  if the two shake hands. If the situation were possible, then we would have a graph with 15 vertices, each of degree 3. So the sum of the degrees of the vertices would be 45, an odd integer. This contradicts Theorem 11.2.

36. Define the function  $f$  from the domain  $A \times B$  (or the set of processors of the grid) to the codomain of corresponding vertices of  $Q_5$  as follows:

$$f((ab, cde)) = abcde, \text{ where } ab \in A, cde \in B, \text{ and } a, b, c, d, e \in \{0, 1\}.$$

If  $f((ab, cde)) = f((a_1b_1, c_1d_1e_1))$ , then  $abcde = a_1b_1c_1d_1e_1$ , so  $a = a_1, b = b_1, c = c_1, d = d_1, e = e_1$ , and  $(ab, cde) = (a_1b_1, c_1d_1e_1)$ , making  $f$  one-to-one. Since  $|A \times B| = 15 =$  the number of vertices (of  $Q_5$ ) in the codomain of  $f$ , it follows from Theorem 5.11 that  $f$  is also onto.

Now let  $\{(ab, cde), (vw, xyz)\}$  be an edge in the  $3 \times 5$  grid. Then either  $ab = vw$  and  $cde, xyz$  differ in (exactly) one component or  $cde = xyz$  and  $ab, vw$  differ in (exactly) one component. Suppose that  $ab = vw$  (so  $a = v, b = w$ ) and  $c = x, d = y$ , but  $e \neq z$ . Then  $\{abcde, vwxyz\}$  is an edge in  $Q_5$ . [The other four cases follow in a similar way.] Conversely, suppose that  $\{f((a_1b_1, c_1d_1e_1)), f((v_1w_1, x_1y_1z_1))\}$  is an edge in the subgraph of  $Q_5$  induced by the codomain of  $f$ . Then  $a_1b_1c_1d_1e_1$  and  $v_1w_1x_1y_1z_1$  differ in (exactly) one component – say the last. Then in the  $3 \times 5$  grid, there is an edge for the vertices  $(a_1b_1, c_1d_10), (a_1b_1, c_1d_11)$ . [Similar arguments can be given for any of the other first four components.] Consequently,  $f$  provides an isomorphism between the  $3 \times 5$  grid and a subgraph of  $Q_5$ .

[Note that the  $3 \times 5$  grid has 22 edges while  $Q_5$  has  $5 \cdot 2^4 = 80$  edges.]

37. Assign the Gray code  $\{00, 01, 11, 10\}$  to the four horizontal levels: top – 00; second (from the top) – 01; second from the bottom – 11; bottom – 10. Likewise, assign the same code to the four vertical levels: left (or, first) – 00; second – 01; third – 11; right (or, fourth) – 10. This provides the labels for  $p_1, p_2, \dots, p_{16}$ , where, for instance,  $p_1$  has the label (00, 00),  $p_2$  has the label (01, 00),  $\dots, p_7$  has the label (11, 01),  $\dots, p_{11}$  has the label (11, 10), and  $p_{16}$  has the label (10, 10).

Define the function  $f$  from the set of 16 vertices of this grid to the vertices of  $Q_4$  by  $f((ab, cd)) = abcd$ . Here  $f((ab, cd)) = f((a_1b_1, c_1d_1)) \Rightarrow abcd = a_1b_1c_1d_1 \Rightarrow a = a_1, b = b_1, c = c_1, d = d_1 \Rightarrow (ab, cd) = (a_1b_1, c_1d_1) \Rightarrow f$  is one-to-one. Since the domain and codomain of  $f$  both contain 16 vertices, it follows from Theorem 5.11 that  $f$  is also onto. Finally, let  $\{(ab, cd), (wx, yz)\}$  be an edge in the grid. Then either  $ab = wx$  and  $cd, yz$  differ in one component or  $cd = yz$  and  $ab, wx$  differ in one component. Suppose that  $ab = wx$  and  $c = y$ , but  $d \neq z$ . Then  $\{abcd, wxyz\}$  is an edge in  $Q_4$ . The other cases follow in a similar way. Conversely, suppose that  $\{f((a_1b_1, c_1d_1)), f((w_1x_1, y_1z_1))\}$  is an edge in  $Q_4$ . Then  $a_1b_1c_1d_1, w_1x_1y_1z_1$  differ in exactly one component – say the first. Then in the

grid, there is an edge for the vertices  $(0b_1, c_1d_1)$ ,  $(1b_1, c_1d_1)$ . The arguments are similar for the other three components. Consequently,  $f$  establishes an isomorphism between the three-by-three grid and a subgraph of  $Q_4$ .

[Note: The three-by-three grid has 24 edges while  $Q_4$  has 32 edges.]

### Section 11.4

1.

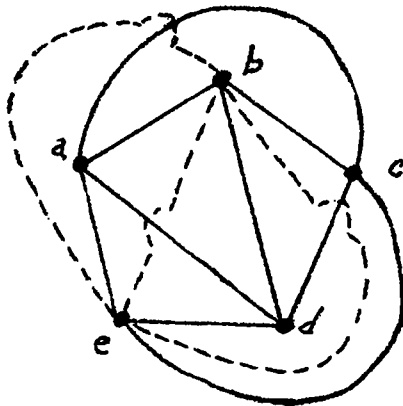

In this situation vertex  $b$  is in the region formed by the edges  $\{a,d\}$ ,  $\{d,c\}$ ,  $\{c,a\}$  and vertex  $e$  is outside of this region. Consequently the edge  $\{b,e\}$  will cross one of the edges  $\{a,d\}$ ,  $\{d,c\}$ ,  $\{a,c\}$  (as shown).

2. From the symmetry in these graphs the following demonstrate the situations we must consider

$K_5$  :

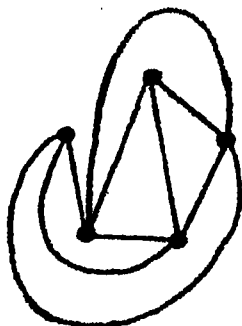
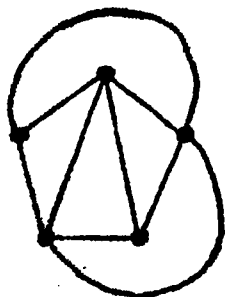

$K_{3,3}$  :

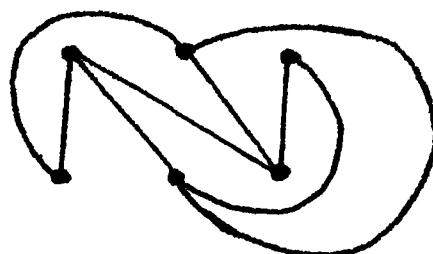

3. (a)

Graph	Number of vertices	Number of edges
$K_{4,7}$	11	28
$K_{7,11}$	18	77
$K_{m,n}$	$m + n$	$mn$

(b)  $m = 6$

4. Let  $G = (V, E)$  be bipartite with  $V$  partitioned as  $V_1 \cup V_2$ , so that each edge in  $E$  is of the form  $\{a, b\}$  where  $a \in V_1, b \in V_2$ . If  $H$  is a subgraph of  $G$  let  $W$  denote the set of vertices for  $H$ . Then  $W = W \cap V = W \cap (V_1 \cup V_2) = (W \cap V_1) \cup (W \cap V_2)$ , where  $(W \cap V_1) \cap (W \cap V_2) = \emptyset$ . If  $\{x, y\}$  is an edge in  $H$  then  $\{x, y\}$  is an edge in  $G$  — where, say,  $x \in V_1$  and  $y \in V_2$ . Hence  $x \in W_1, y \in W_2$  and  $H$  is a bipartite graph.

5. (a) Let  $V_1 = \{a, d, e, h\}$  and  $V_2 = \{b, c, f, g\}$ . Then every vertex of  $G$  is in  $V_1 \cup V_2$  and  $V_1 \cap V_2 = \emptyset$ . Also every edge in  $G$  may be written as  $\{x, y\}$  where  $x \in V_1$  and  $y \in V_2$ . Consequently, the graph  $G$  in part (a) of the figure is bipartite.

(b) Let  $V'_1 = \{a, b, g, h\}$  and  $V'_2 = \{c, d, e, f\}$ . Then every vertex of  $G'$  is in  $V'_1 \cup V'_2$  and  $V'_1 \cap V'_2 = \emptyset$ . Since every edge of  $G'$  may be written as  $\{x, y\}$ , with  $x \in V'_1$  and  $y \in V'_2$ , it follows that this graph is bipartite. In fact  $G'$  is (isomorphic to) the complete bipartite graph  $K_{4,4}$ .

(c) This graph is *not* bipartite. If  $G'' = (V'', E'')$  were bipartite, let the vertices of  $G''$  be partitioned as  $V''_1 \cup V''_2$ , where each edge in  $G''$  is of the form  $\{x, y\}$  with  $x \in V''_1$  and  $y \in V''_2$ . We assume vertex  $a$  is in  $V''_1$ . Now consider the vertices  $b, c, d$ , and  $e$ . Since  $\{a, b\}$  and  $\{a, c\}$  are edges of  $G''$  we must have  $b, c \in V''_2$ . Also,  $\{b, d\}$  is an edge in the graph, so  $d$  is in  $V''_1$ . But then  $\{d, e\} \in E'' \Rightarrow e \in V''_2$ , while  $\{c, e\} \in E'' \Rightarrow e \in V''_1$ .

6. There are four vertices in  $K_{1,3}$  and we can select four vertices from those of  $K_n$  in  $\binom{n}{4}$  ways. Since each of the four vertices (in each of the  $\binom{n}{4}$  selections) can be the unique vertex of degree 3 in  $K_{1,3}$ , there are  $4\binom{n}{4}$  subgraphs of  $K_n$  that are isomorphic to  $K_{1,3}$ .

Alternately, select the vertex of degree 3 in  $K_{1,3}$  — this can be done in  $n$  ways. Then select

the remaining pendant vertices — this can be done in  $\binom{n-1}{3}$  ways. Hence the number of subgraphs of  $K_n$  that are isomorphic to  $K_{1,3}$  is

$$n \binom{n-1}{3} = (n)(n-1)(n-2)(n-3)/6 = (4)[(n)(n-1)(n-2)(n-3)/24] = 4 \binom{n}{4}.$$

7. The vertices in  $K_{m,n}$  may be partitioned as  $V_1 \cup V_2$  where  $|V_1| = m$ ,  $|V_2| = n$ , and each edge of the graph has the form  $\{x, y\}$  where  $x \in V_1$  and  $y \in V_2$ .
- (a) In order to obtain a cycle of length four we need to select two vertices from each of  $V_1$  and  $V_2$ . This can be done in  $\binom{m}{2} \binom{n}{2}$  ways — each resulting in a distinct cycle of length four.  
 [Note: Say we select vertices  $a, b$  from  $V_1$  and vertices  $c, d$  from  $V_2$ . We do *not* distinguish the cycles  $a \rightarrow c \rightarrow b \rightarrow d \rightarrow a$  and  $a \rightarrow d \rightarrow b \rightarrow c \rightarrow a$ .]
- (b) For a path of length two there is one vertex of (path) degree 2 and two vertices of (path) degree 1. If the vertex of (path) degree 2 is in  $V_1$  then there are  $m \binom{n}{2}$  such paths. There are  $n \binom{m}{2}$  such paths when the vertex of (path) degree 2 is in  $V_2$ . Hence there are  $m \binom{n}{2} + n \binom{m}{2} = (1/2)(mn)[m + n - 2]$  paths of length 2 in  $K_{m,n}$ .
- (c) Here a path of length 3 has the form  $a \rightarrow b \rightarrow c \rightarrow d$  where  $a, c \in V_1$  and  $b, d \in V_2$ . By the rule of product there are  $(m)(n)(m-1)(n-1) = 4 \binom{m}{2} \binom{n}{2}$  such paths in  $K_{m,n}$ .
8. (a) 2                      (b) 6 (= 2(3))                      (c) 14 (= 2(7))                      (d)  $2m$
9. (a) 6                      (b)  $(1/2)(7)(3)(6)(2)(5)(1)(4) = 2520$                       (c) 50,295,168,000  
 (d)  $(1/2)(n)(m)(n-1)(m-1)(n-2) \cdots (2)(n-(m+1))(1)(n-m)$
10. Let  $G = (V, E)$  be bipartite with  $V = V_1 \cup V_2$ ,  $V_1 \cap V_2 = \emptyset$ . If  $G$  has a cycle of odd length then there is an edge in the cycle of the form  $\{x, y\}$  with  $x, y \in V_1$  (or  $x, y \in V_2$ ). This contradicts the definition of a bipartite graph.
11. Partition  $V$  as  $V_1 \cup V_2$  with  $|V_1| = m$ ,  $|V_2| = v - m$ . If  $G$  is bipartite, then the maximum number of edges that  $G$  can have is  $m(v - m) = -[m - (v/2)]^2 + (v/2)^2$ , a function of  $m$ . For a given value of  $v$ , when  $v$  is even,  $m = v/2$  maximizes  $m(v - m) = (v/2)[v - (v/2)] = (v/2)^2$ . For  $v$  odd,  $m = (v - 1)/2$  or  $m = (v + 1)/2$  maximizes  $m(v - m) = [(v - 1)/2][v - ((v - 1)/2)] = [(v - 1)/2][(v + 1)/2] = [(v + 1)/2][v - ((v + 1)/2)] = (v^2 - 1)/4 = \lfloor (v/2)^2 \rfloor < (v/2)^2$ . Hence if  $|E| > (v/2)^2$ ,  $G$  cannot be bipartite.
12. (a) There are 3: (i)  $K_{1,5}$ ; (ii)  $K_{2,4}$ ; and (iii)  $K_{3,3}$ .  
 (b)  $\lfloor n/2 \rfloor$  for  $n \in \mathbb{Z}^+$ ,  $n \geq 2$ .

13. (a)
- |          |          |
|----------|----------|
| a: {1,2} | f: {4,5} |
| b: {3,4} | g: {2,5} |
| c: {1,5} | h: {2,3} |
| d: {2,4} | i: {1,3} |
| e: {3,5} | j: {1,4} |

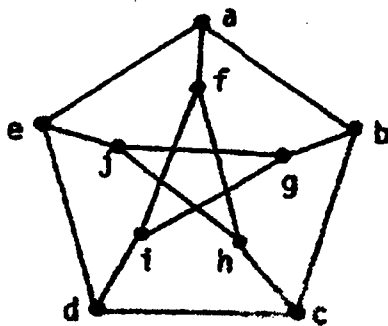

(b)  $G$  is (isomorphic to) the Petersen graph. (See Fig. 11.52(a)).

14. (1) (2) (3)

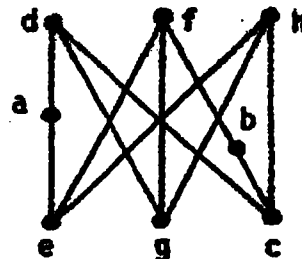
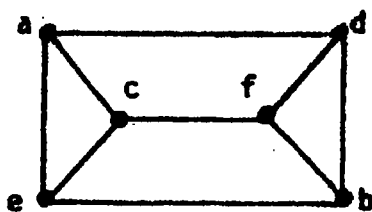
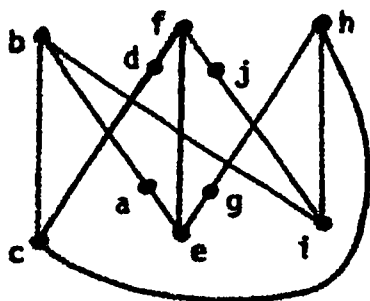

Graph (1) shows that the first graph contains a subgraph homeomorphic to  $K_{3,3}$ , so it is not planar. The second graph is planar and isomorphic to the second graph of the exercise. The third graph provides a subgraph homeomorphic to  $K_{3,3}$  so the third graph given here is not planar. Graph (6) is not planar because it contains a subgraph homeomorphic to  $K_8$ .

(4)

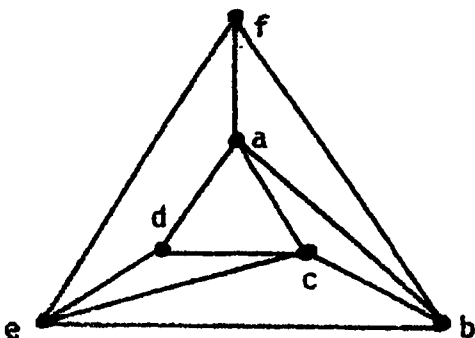

(5)

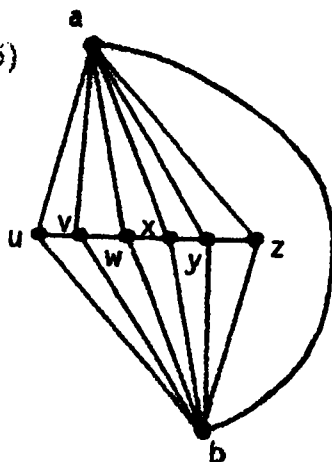

(6)

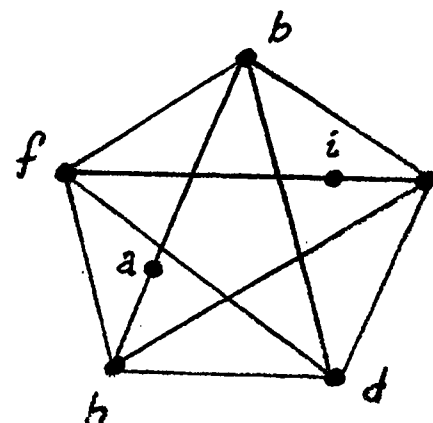

15. The result follows if and only if  $mn$  is even (that is, at least one of  $m, n$  is even).

Suppose, without loss of generality, that  $m$  is even — say,  $m = 2t$ . Let  $V$  denote the vertex set of  $K_{m,n}$  where  $V = V_1 \cup V_2$  and  $V_1 = \{v_1, v_2, \dots, v_t, v_{t+1}, \dots, v_m\}$ ,  $V_2 = \{w_1, w_2, \dots, w_n\}$ . The  $mn$  edges in  $K_{m,n}$  are of the form  $\{v_i, w_j\}$  where  $1 \leq i \leq m$ ,  $1 \leq j \leq n$ . Now consider the subgraphs  $G_1, G_2$  of  $K_{m,n}$  where  $G_1$  is induced by  $\{v_1, v_2, \dots, v_t\} \cup V_2$  and  $G_2$  is induced by  $\{v_{t+1}, v_{t+2}, \dots, v_m\} \cup V_2$ . Each of  $G_1, G_2$  is isomorphic to  $K_{t,n}$ , and every edge in  $K_{m,n}$  is in exactly one of  $G_1, G_2$ .

If both  $m, n$  are odd, then  $K_{m,n}$  has an odd number of edges and cannot be decomposed into two isomorphic subgraphs — since each such subgraph has the same number of edges as the other.

16. Consider how the vertices of the Petersen graph are labeled in Fig. 11.52(a). The following correspondence of vertices provides an isomorphism for the two graphs:

$$\begin{array}{cccccc} a \rightarrow s & b \rightarrow v & c \rightarrow z & d \rightarrow y & e \rightarrow t \\ f \rightarrow u & g \rightarrow r & h \rightarrow w & i \rightarrow x & j \rightarrow q \end{array}$$

17. (a) There are 17 vertices, 34 edges and 19 regions and  $v - e + r = 17 - 34 + 19 = 2$ .  
 (b) Here we find 10 vertices, 24 edges and 16 regions and  $v - e + r = 10 - 24 + 16 = 2$ .
18. Proof: Since each region has at least five edges in its boundary,  $2|E| > 5(53)$ , or  $|E| \geq (1/2)(5)(53)$ . And from Theorem 11.6 we have  $|V| = |E| - 53 + 2 = |E| - 51 \geq (1/2)(5)(53) - 51 = (265/2) - 51 = 81\frac{1}{2}$ . Hence  $|V| \geq 82$ .
19. 10
20. (a) For each component  $C_i = (V_i, E_i)$ ,  $1 \leq i \leq n$ , of  $G$ , if  $e_i = |E_i|$  and  $v_i = |V_i|$  then  $e_i - v_i + 2 = r_i$ . Summing as  $i$  goes from 1 to  $n$  we have  $e - v + 2n = r + (n - 1)$  because the infinite region is counted  $n = \kappa(G)$  times. Hence  $e - v + n + 1 = r = e - v + [\kappa(G) + 1]$ .  
 (b) Using the same notation as in part (a) we have  $3r_i \leq 2e_i$ ,  $1 \leq i \leq n$ , so  $3r \leq \sum_{i=1}^n (3r_i) \leq \sum_{i=1}^n 2e_i = 2e$ . Also,  $e_i \leq 3v_i - 6$ ,  $1 \leq i \leq n$ , so  $e = \sum_{i=1}^n e_i \leq \sum_{i=1}^n (3v_i - 6) = 3v - 6n \leq 3v - 6$ .
21. If not,  $\deg(v) \geq 6$  for all  $v \in V$ . Then  $2e = \sum_{v \in V} \deg(v) \geq 6|V|$ , so  $e \geq 3|V|$ , contradicting  $e \leq 3|V| - 6$  (Corollary 11.3.)
22. (a) Suppose that  $G = (V, E)$  with  $|V| = 11$ . Then  $\bar{G} = (V, E_1)$  where  $\{a, b\} \in E_1$  iff  $\{a, b\} \notin E$ . Let  $e = |E|$ ,  $e_1 = |E_1|$ . If both  $G$  and  $\bar{G}$  are planar, then by Corollary 11.3 (and part (b) of Exercise 20, if necessary),  $e \leq 3|V| - 6 = 33 - 6 = 27$  and  $e_1 \leq 3|V| - 6 = 27$ . But with  $|V| = 11$ , there are  $\binom{11}{2} = 55$  edges in  $K_{11}$ , so  $|E| + |E_1| = 55$  and either  $e \geq 28$  or  $e_1 \geq 28$ . Hence, one of  $G, \bar{G}$  must be planar.

If  $G = (V, E)$  and  $|V| > 11$ , consider an induced subgraph of  $G$  on  $V' \subset V$  where  $|V'| = 11$ .

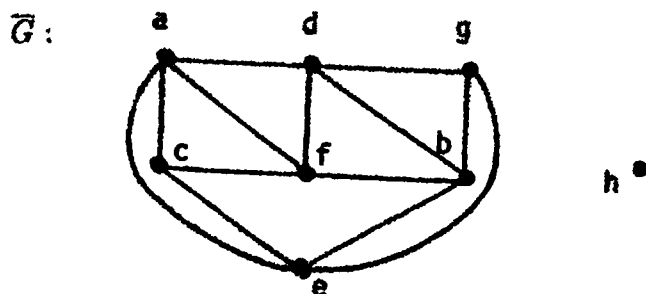
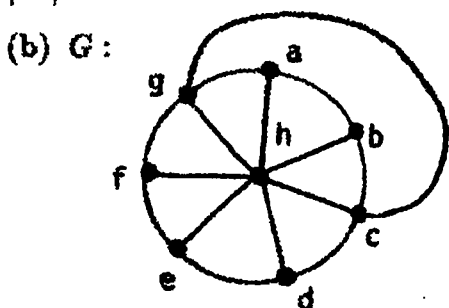

23. (a)  $2e \geq kr = k(2 + e - v) \implies (2 - k)e \geq k(2 - v) \implies e \leq [k/(k - 2)](v - 2)$ .  
 (b) 4  
 (c) In  $K_{3,3}$ ,  $e = 9$ ,  $v = 6$ .  $[k/(k - 2)](v - 2) = (4/2)(4) = 8 < 9 = e$ . Since  $K_{3,3}$  is connected, it must be nonplanar.  
 (d) Here  $k = 5$ ,  $v = 10$ ,  $e = 15$  and  $[k/(k - 2)](v - 2) = (5/3)(8) = (40/3) < 15 = e$ . Since the Petersen graph is connected, it must be nonplanar.

24. (a)

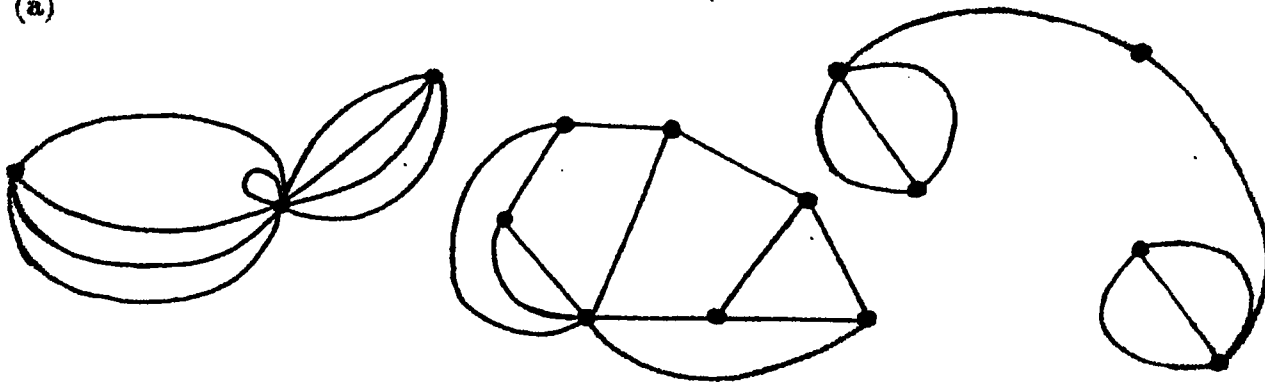

(b) There are no pendant vertices. But this does not contradict the condition mentioned because the loops contain other vertices and edges of the graph.

25. (a) The dual for the tetrahedron (Fig. 11.59(b)) is the graph itself. For the graph (cube) in Fig. 11.59(d) the dual is the octahedron, and vice versa. Likewise, the dual of the dodecahedron is the icosahedron, and vice versa.  
 (b) For  $n \in \mathbb{Z}^+$ ,  $n \geq 3$ , the dual of the wheel graph  $W_n$  is  $W_n$  itself.

26. (a) The correspondence  $a \rightarrow v$ ,  $b \rightarrow w$ ,  $c \rightarrow y$ ,  $d \rightarrow z$ ,  $e \rightarrow x$  provides an isomorphism.

- (b) (1)

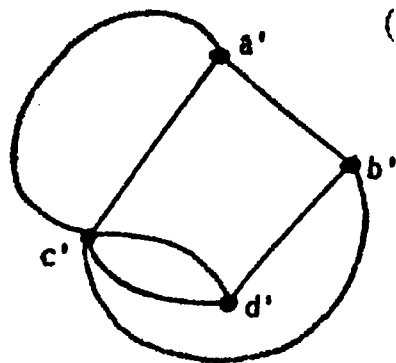

- (2)

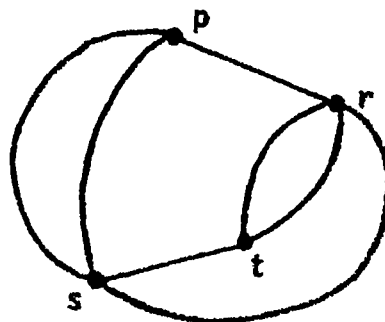

(c) In the first graph in part (b) vertex  $c'$  has degree 5. Since no vertex has degree 5 in the second graph, the two graphs cannot be isomorphic.

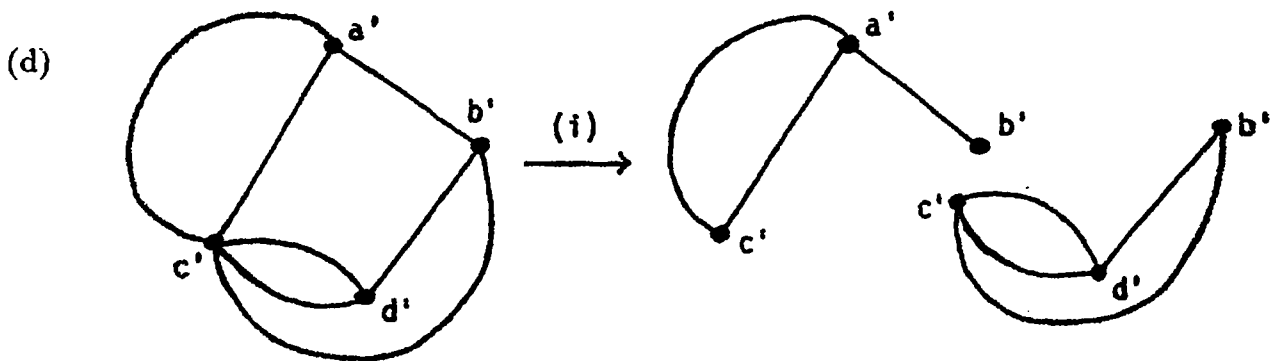

(e)  $\{\{a', c'\}, \{c', b'\}, \{b', a'\}\}; \{\{p, r\}, \{r, t\}, \{r, t\}, \{r, s\}\}$ .

27.

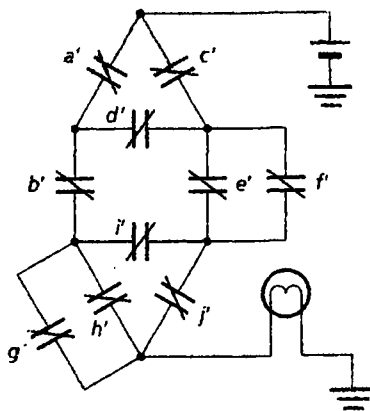

28. The number of vertices in  $G^d$ , the dual of  $G$ , is  $r$ , the number of regions in a planar depiction of  $G$ . Since  $G$  is isomorphic to  $G^d$  it follows that  $r = n$ . Consequently,  $|V| - |E| + r = 2 \Rightarrow n - |E| + n = 2 \Rightarrow |E| = 2n - 2$ .

29. Proof:

a) As we mentioned in the remark following Example 11.18, when  $G_1, G_2$  are homeomorphic graphs then they may be regarded as isomorphic except, possibly, for vertices of degree 2. Consequently, two such graphs will have the same number of vertices of odd degree.

b) Now if  $G_1$  has an Euler trail, then  $G_1$  (is connected and) has all vertices of even degree – except two, those being the vertices at the beginning and end of the Euler trail. From part (a)  $G_2$  is likewise connected with all vertices of even degree, except for two of odd degree. Consequently,  $G_2$  has an Euler trail. [The converse follows in a similar way.]

c) If  $G_1$  has an Euler circuit, then  $G_1$  (is connected and) has all vertices of even degree. From part (a)  $G_2$  is likewise connected with all vertices of even degree, so  $G_2$  has an Euler

circuit. [The converse follows in a similar manner.]

### Section 11.5

1.

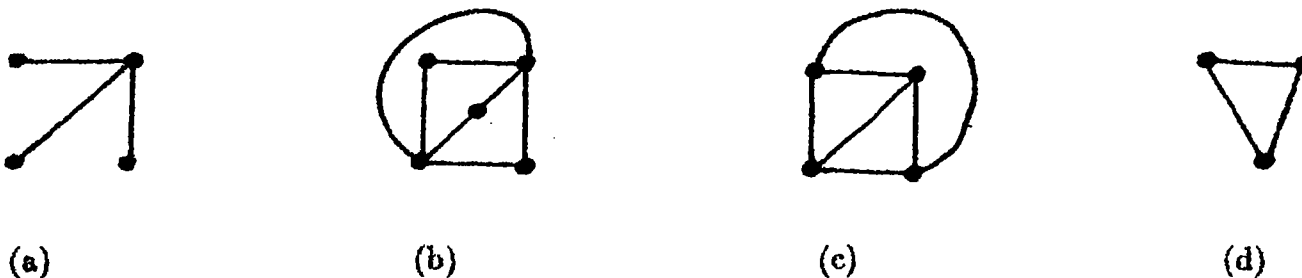

2. The graph is a path (cycle).

3. (a) Hamilton cycle:  $a \rightarrow g \rightarrow k \rightarrow i \rightarrow h \rightarrow b \rightarrow c \rightarrow d \rightarrow j \rightarrow f \rightarrow e \rightarrow a$

(b) Hamilton cycle:  $a \rightarrow d \rightarrow b \rightarrow e \rightarrow g \rightarrow j \rightarrow i \rightarrow f \rightarrow h \rightarrow c \rightarrow a$

(c) Hamilton cycle:  $a \rightarrow h \rightarrow e \rightarrow f \rightarrow g \rightarrow i \rightarrow d \rightarrow c \rightarrow b \rightarrow a$

(d) The edges  $\{a, c\}$ ,  $\{c, d\}$ ,  $\{d, b\}$ ,  $\{b, e\}$ ,  $\{e, f\}$ ,  $\{f, g\}$  provide a Hamilton path for the given graph. However, there is no Hamilton cycle, for such a cycle would have to include the edges  $\{b, d\}$ ,  $\{b, e\}$ ,  $\{a, c\}$ ,  $\{a, e\}$ ,  $\{g, f\}$ , and  $\{g, e\}$  – and, consequently, the vertex  $e$  will have degree greater than 2.

(e) The path  $a \rightarrow b \rightarrow c \rightarrow d \rightarrow e \rightarrow j \rightarrow i \rightarrow h \rightarrow g \rightarrow f \rightarrow k \rightarrow l \rightarrow m \rightarrow n \rightarrow o$  is one possible Hamilton path for this graph. Another possibility is the path  $a \rightarrow b \rightarrow c \rightarrow d \rightarrow i \rightarrow h \rightarrow g \rightarrow f \rightarrow k \rightarrow l \rightarrow m \rightarrow n \rightarrow o \rightarrow j \rightarrow e$ . However, there is no Hamilton cycle. For if we try to construct a Hamilton cycle we must include the edges  $\{a, b\}$ ,  $\{a, f\}$ ,  $\{f, k\}$ ,  $\{k, l\}$ ,  $\{d, e\}$ ,  $\{e, j\}$ ,  $\{j, o\}$  and  $\{n, o\}$ . This then forces us to eliminate the edges  $\{f, g\}$  and  $\{i, j\}$  from further consideration. Now consider the vertex  $i$ . If we use edges  $\{d, i\}$  and  $\{i, n\}$ , then we have a cycle on the vertices  $d, e, j, o, n$  and  $i$  – and we cannot get a Hamilton cycle for the given graph. Hence we must use only one of the edges  $\{d, i\}$  and  $\{i, n\}$ . Because of the symmetry in this graph let us select edge  $\{d, i\}$  – and then edge  $\{h, i\}$  so that vertex  $i$  will have degree 2 in the Hamilton cycle we are trying to construct. Since edges  $\{d, i\}$  and  $\{d, e\}$  are now being used, we eliminate edge  $\{c, d\}$  and this then forces us to include edges  $\{b, c\}$  and  $\{c, h\}$  in our construction. Also we must include the edge  $\{m, n\}$  since we eliminated edge  $\{i, n\}$  from consideration. Next we eliminate edges  $\{h, m\}$ ,  $\{h, g\}$  and  $\{b, g\}$ . Finally we must include edge  $\{m, l\}$  and then eliminate edge  $\{l, g\}$ . But now we have eliminated the four edges  $\{b, g\}$ ,  $\{f, g\}$ ,  $\{h, g\}$  and  $\{l, g\}$  and  $g$  is consequently isolated.

(f) For this graph we find the Hamilton cycle  $a \rightarrow b \rightarrow c \rightarrow d \rightarrow e \rightarrow j \rightarrow i \rightarrow h \rightarrow g \rightarrow l \rightarrow m \rightarrow n \rightarrow o \rightarrow t \rightarrow s \rightarrow r \rightarrow q \rightarrow p \rightarrow k \rightarrow f \rightarrow a$ .

4. (a) Consider the graph as shown in Fig. 11.52(a). We demonstrate one case. Start at vertex  $a$  and consider the partial path  $a \rightarrow f \rightarrow i \rightarrow d$ . These choices require the removal of edges  $\{f, h\}$  and  $\{g, i\}$  from further consideration since each vertex of the graph will be incident with exactly two edges in the Hamilton cycle. At vertex  $d$  we can

go to either vertex  $c$  or vertex  $e$ . (i) If we go to vertex  $c$  we eliminate edge  $\{e, d\}$  from consideration, but we must now include edges  $\{e, j\}$  and  $\{e, a\}$ , and this forces the elimination of edge  $\{a, b\}$ . Now we must consider vertex  $b$ , for by eliminating edge  $\{a, b\}$  we are now required to include edges  $\{b, g\}$  and  $\{b, c\}$  in the cycle. This forces us to remove edge  $\{c, h\}$  from further consideration. But we have now removed edges  $\{f, h\}$  and  $\{c, h\}$  and there is only one other edge that is incident with  $h$ , so no Hamilton cycle can be obtained. (ii) Selecting vertex  $e$  after  $d$ , we remove edge  $\{d, c\}$  and include  $\{c, h\}$  and  $\{b, c\}$ . Having removed  $\{g, i\}$  we must include  $\{g, b\}$  and  $\{g, j\}$ . This forces the elimination of  $\{a, b\}$ , the inclusion of  $\{a, e\}$  (and the elimination of  $\{e, j\}$ ). We now have a cycle containing  $a, f, i, d, e$ , hence this method has also failed.

However, this graph does have a Hamilton path:  $a \rightarrow b \rightarrow c \rightarrow d \rightarrow e \rightarrow j \rightarrow h \rightarrow f \rightarrow i \rightarrow g$ .

(b) For example, remove vertex  $j$  and the edges  $\{e, j\}, \{g, j\}, \{h, j\}$ . Then  $e \rightarrow a \rightarrow f \rightarrow h \rightarrow c \rightarrow b \rightarrow g \rightarrow i \rightarrow d \rightarrow e$  provides a Hamilton cycle for this subgraph.

5. (a) If we remove any one of the vertices  $a, b$  or  $g$ , the resulting subgraph has a Hamilton cycle. For example, upon removing vertex  $a$ , we find the Hamilton cycle  $b \rightarrow d \rightarrow c \rightarrow f \rightarrow g \rightarrow e \rightarrow b$ .

(b) The following Hamilton cycle exists if we remove vertex  $g$ :  $a \rightarrow b \rightarrow c \rightarrow d \rightarrow e \rightarrow j \rightarrow o \rightarrow n \rightarrow i \rightarrow h \rightarrow m \rightarrow l \rightarrow k \rightarrow f \rightarrow a$ . A symmetric situation results upon removing vertex  $i$ .

6. Let the vertices on the cycle (rim) of  $W_n$  be consecutively denoted by  $v_1, v_2, \dots, v_n$ , and let  $v_{n+1}$  denote the additional (central) vertex of  $W_n$ . Then the following cycles provide  $n$  Hamilton cycles for the wheel graph  $W_n$ .

(1)  $v_1 \rightarrow v_{n+1} \rightarrow v_2 \rightarrow v_3 \rightarrow v_4 \rightarrow \dots \rightarrow v_{n-1} \rightarrow v_n \rightarrow v_1$ ;

(2)  $v_1 \rightarrow v_2 \rightarrow v_{n+1} \rightarrow v_3 \rightarrow v_4 \rightarrow \dots \rightarrow v_{n-1} \rightarrow v_n \rightarrow v_1$ ;

(3)  $v_1 \rightarrow v_2 \rightarrow v_3 \rightarrow v_{n+1} \rightarrow v_4 \rightarrow \dots \rightarrow v_{n-1} \rightarrow v_n \rightarrow v_1$ ;

$\vdots$

$(n-1)$   $v_1 \rightarrow v_2 \rightarrow v_3 \rightarrow v_4 \rightarrow \dots \rightarrow v_{n-1} \rightarrow v_{n+1} \rightarrow v_n \rightarrow v_1$ ; and

$(n)$   $v_1 \rightarrow v_2 \rightarrow v_3 \rightarrow v_4 \rightarrow \dots \rightarrow v_{n-1} \rightarrow v_n \rightarrow v_{n+1} \rightarrow v_1$ .

7. (a)  $(1/2)(n-1)!$                       (b) 10                      (c) 9

8. (a) Partition the vertices of  $K_{n,n}$  as  $X \cup Y$  where  $|X| = |Y| = n$ . Write  $X = \{x_1, x_2, \dots, x_n\}$ ,  $Y = \{y_1, y_2, \dots, y_n\}$ ; each edge of  $K_{n,n}$  is of the form  $\{x_i, y_j\}$  where  $1 \leq i, j \leq n$ . Since  $x_1$  is on every Hamilton cycle of  $K_{n,n}$ , start with  $x_1$ . There are then  $n$  choices for  $y_j$  where  $\{x_1, y_j\}$  is on the cycle. From  $y_j$  we can return to  $X$  in  $n-1$  ways (we cannot use  $x_1$  again), forming the second edge  $\{y_j, x_i\}$ , where  $2 \leq i \leq n$ . Continuing in this manner there are  $(n-1)n!$  results. Since directions are not assigned to any of the edges we get a total of  $(1/2)(n-1)n!$  Hamilton cycles for  $K_{n,n}$ .

(b) In this case the "starting" vertex of a Hamilton path is in one of  $X$  or  $Y$  (as described in part (a)) and the "terminating" vertex is then in the other set. The number

of such paths is  $(n!)^2$ . (Note:  $n = 1$  makes sense in this part but not for the formula in part (a).)

9. Let  $G = (V, E)$  be a loop-free undirected graph with no odd cycles. We assume that  $G$  is connected – otherwise, we work with the components of  $G$ . Select any vertex  $x$  in  $V$  and let  $V_1 = \{v \in V \mid d(x, v), \text{ the length of a shortest path between } x \text{ and } v, \text{ is odd}\}$  and  $V_2 = \{w \in V \mid d(x, w), \text{ the length of a shortest path between } x \text{ and } w, \text{ is even}\}$ . Note that (i)  $x \in V_2$ ; (ii)  $V = V_1 \cup V_2$ ; and (iii)  $V_1 \cap V_2 = \emptyset$ . We claim that each edge  $\{a, b\}$  in  $E$  has one vertex in  $V_1$  and the other vertex in  $V_2$ .

For suppose that  $e = \{a, b\} \in E$  with  $a, b \in V_1$ . (The proof for  $a, b \in V_2$  is similar.) Let  $E_a = \{\{a, v_1\}, \{v_1, v_2\}, \dots, \{v_{m-1}, x\}\}$  be the  $m$  edges in a shortest path from  $a$  to  $x$ , and let  $E_b = \{\{b, v'_1\}, \{v'_1, v'_2\}, \dots, \{v'_{n-1}, x\}\}$  be the  $n$  edges in a shortest path from  $b$  to  $x$ . Note that  $m, n$  are both odd. If  $\{v_1, v_2, \dots, v_{m-1}\} \cap \{v'_1, v'_2, \dots, v'_{n-1}\} = \emptyset$ , then the set of edges  $E' = \{\{a, b\}\} \cup E_a \cup E_b$  provides an odd cycle in  $G$ . Otherwise, let  $w (\neq x)$  be the first vertex where the paths come together, and let  $E'' = \{\{a, b\}\} \cup \{\{a, v_1\}, \{v_1, v_2\}, \dots, \{v_i, w\}\} \cup \{\{b, v'_1\}, \{v'_1, v'_2\}, \dots, \{v'_j, w\}\}$ , for some  $1 \leq i \leq m-1$  and  $1 \leq j \leq n-1$ . Then either  $E''$  provides an odd cycle for  $G$  or  $E' - E''$  contains an odd cycle for  $G$ .

10. (a) Suppose that  $G$  has a Hamilton cycle  $C$ . Then  $C$  contains  $|V|$  edges and the vertices on  $C$  must alternate between vertices in  $V_1$  and those in  $V_2$  because  $G$  is bipartite. This forces  $|V|$  to be even and  $|V_1| = |V_2|$ .
- (b) In a similar way, if  $G$  has a Hamilton path  $P$ , then  $P$  has  $|V| - 1$  edges and the vertices on  $P$  must alternate between the vertices in  $V_1$  and those in  $V_2$ . Since  $|V_1| \neq |V_2|$ , it follows that  $|V_1| - |V_2| = \pm 1$ .
- (c) Let  $V = \{a, b, c, d, e\}$  with  $V_1 = \{a, b\}$ ,  $V_2 = \{c, d, e\}$  and  $E = \{\{a, c\}, \{a, d\}, \{a, e\}, \{b, c\}\}$ .

11. (a)

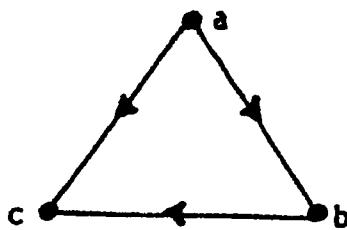
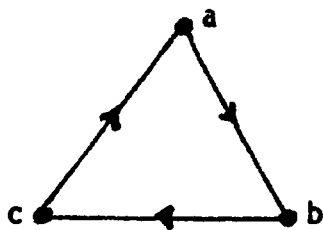

(b)

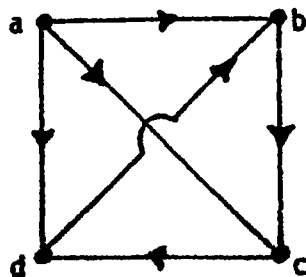
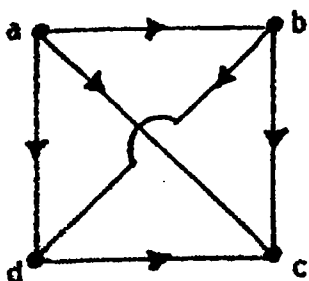

$$\begin{aligned} \text{od}(a) &= 3 & \text{id}(a) &= 0 \\ \text{od}(b) &= 2 & \text{id}(b) &= 1 \\ \text{od}(c) &= 0 & \text{id}(c) &= 3 \\ \text{od}(d) &= 1 & \text{id}(d) &= 2 \end{aligned}$$

$$\begin{aligned} \text{od}(a) &= 3 & \text{id}(a) &= 0 \\ \text{od}(b) &= 1 & \text{id}(b) &= 2 \\ \text{od}(c) &= 1 & \text{id}(c) &= 2 \\ \text{od}(d) &= 1 & \text{id}(d) &= 2 \end{aligned}$$

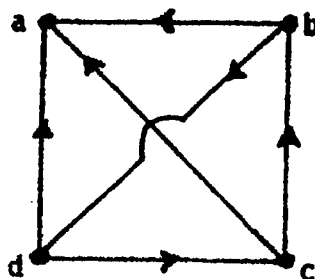
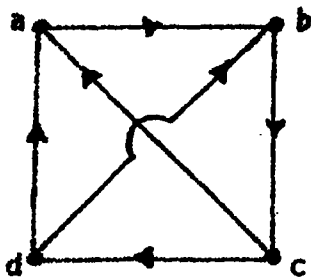

$$\begin{aligned} \text{od}(a) &= 1 & \text{id}(a) &= 2 \\ \text{od}(b) &= 1 & \text{id}(b) &= 2 \\ \text{od}(c) &= 2 & \text{id}(c) &= 1 \\ \text{od}(d) &= 2 & \text{id}(d) &= 1 \end{aligned}$$

$$\begin{aligned} \text{od}(a) &= 0 & \text{id}(a) &= 3 \\ \text{od}(b) &= 2 & \text{id}(b) &= 1 \\ \text{od}(c) &= 2 & \text{id}(c) &= 1 \\ \text{od}(d) &= 2 & \text{id}(d) &= 1 \end{aligned}$$

12. Proof: From Example 11.26 we know the result is true for  $n = 2$ . Assume that  $Q_n$  has a Hamilton cycle for some arbitrary (but fixed)  $n \geq 2$ . Now consider  $Q_{n+1}$ . From Example 11.12 we know that  $Q_{n+1}$  can be constructed from two copies of  $Q_n$  - one copy,  $Q_{n,0}$ , induced by the vertices of  $Q_{n+1}$  that start with 0, the other copy,  $Q_{n,1}$ , induced by the

vertices of  $Q_{n+1}$  that start with 1. Each of  $Q_{n,0}, Q_{n,1}$  has a Hamilton cycle – each may have more than one but we agree to pick the same cycle in each. [The only difference in the cycles is the first bit in the vertices of an edge – that is, if  $\{0x, 0y\}$  is an edge in the Hamilton cycle for  $Q_{n,0}$  (where  $x, y$  are binary strings of length  $n$  that differ in only one position), then  $\{1x, 1y\}$  is the corresponding edge in the Hamilton cycle for  $Q_{n,1}$ .] Select edges  $\{0v, 0w\}$  and  $\{1v, 1w\}$  from the Hamilton cycles for  $Q_{n,0}$  and  $Q_{n,1}$ , respectively. Remove these edges and replace them with the edges  $\{0v, 1v\}, \{0w, 1w\}$  (in  $Q_{n+1}$ ). The result is a Hamilton cycle for  $Q_{n+1}$ .

It now follows from the Principle of Mathematical Induction that  $Q_n$  has a Hamilton cycle for all  $n \geq 2$ .

13. Proof: If not, there exists a vertex  $x$  such that  $(v, x) \notin E$  and, for all  $y \in V, y \neq v, x$ , if  $(v, y) \in E$  then  $(y, x) \notin E$ . Since  $(v, x) \notin E$ , we have  $(x, v) \in E$ , as  $T$  is a tournament. Also, for each  $y$  mentioned earlier, we also have  $(x, y) \in E$ . Consequently,  $od(x) \geq od(v) + 1$  – contradicting  $od(v)$  being a maximum!

14. Let  $G$  be any path with more than three vertices.

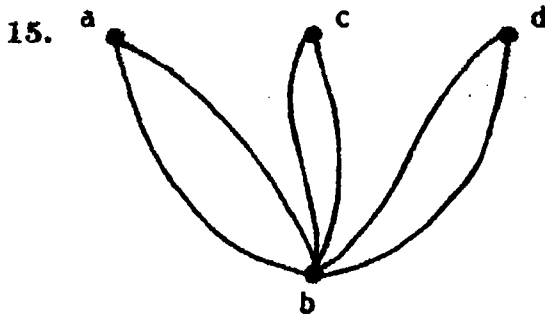

For the multigraph in the given figure,  $|V| = 4$  and  $\deg(a) = \deg(c) = \deg(d) = 2$  and  $\deg(b) = 6$ . Hence  $\deg(x) + \deg(y) \geq 4 > 3 = 4 - 1$  for all nonadjacent  $x, y \in V$ , but the multigraph has no Hamilton path.

16. Corollary 11.4: Proof: For all  $x, y \in V, \deg(x) + \deg(y) \geq 2[(n - 1)/2] = n - 1$ , so the result follows from Theorem 11.8.

Corollary 11.5: Proof: Let  $a, b \in V$  where  $\{a, b\} \notin E$ . Then  $\deg(a) + \deg(b) \geq (n/2) + (n/2) = n$ , so the result follows from Theorem 11.9.

17. For  $n \geq 5$  let  $C_n = (V, E)$  denote the cycle on  $n$  vertices. Then  $C_n$  has (actually is) a Hamilton cycle, but for all  $v \in V, \deg(v) = 2 < n/2$ .

18. Construct a graph with 12 vertices, one for each person. If two people know each other, draw an edge connecting their corresponding vertices. By Theorem 11.9 this graph has a Hamilton cycle and this cycle provides such a seating arrangement.

19. This follows from Theorem 11.9, since for all (nonadjacent)  $x, y \in V, \deg(x) + \deg(y) = 12 > 11 = |V|$ .

20. Proof: Let  $x, y \in V$  with  $\{x, y\} \in E$ . Consequently,  $x, y$  are nonadjacent in  $\overline{G}$ . In  $\overline{G}$  we find that  $\deg_{\overline{G}}(x) = \deg_{\overline{G}}(y) \geq 2n + 2 - n = n + 2$ , so  $\deg_{\overline{G}}(x) + \deg_{\overline{G}}(y) = 2n + 4 > 2n + 2 = |V|$ . Therefore, by virtue of Theorem 11.9, the graph  $\overline{G}$  has a Hamilton cycle.

21. When  $n = 5$  the graphs  $C_5$  and  $\bar{C}_5$  are isomorphic, and both are Hamilton cycles on five vertices.

For  $n \geq 6$ , let  $u, v$  denote nonadjacent vertices in  $\bar{C}_n$ . Since  $\deg(u) = \deg(v) = n - 3$  we find that  $\deg(u) + \deg(v) = 2n - 6$ . Also,  $2n - 6 \geq n \iff n \geq 6$ , so it follows from Theorem 11.9 that the cocycle  $\bar{C}_n$  contains a Hamilton cycle when  $n \geq 6$ .

22. (a) If  $x \neq v$  and  $y \neq v$ , then  $\deg(x) = \deg(y) = n - 2$ , and  $\deg(x) + \deg(y) = 2n - 4 \geq n$ , for  $n \geq 4$ .

If one of  $x, y$  is  $v$ , say  $x$ , then  $\deg(x) = 2$  and  $\deg(y) = n - 2$ , and  $\deg(x) + \deg(y) = n$ .

(b) From part (a) it follows that  $\deg(x) + \deg(y) \geq n$  for all nonadjacent  $x, y$  in  $V$ . Therefore  $G_n$  has a Hamilton cycle — by virtue of Theorem 11.9.

(c) Here  $|E| = \binom{n-1}{2} - 1 + 2$ , where we subtract 1 for the edge  $\{v_1, v_2\}$ , and add 2 for the pair of edges  $\{v_1, v\}$  and  $\{v, v_2\}$ . Consequently,  $|E| = \binom{n-1}{2} + 1$ .

(d) The results in parts (b) and (c) do not contradict Corollary 11.6. They show that the converse of this corollary is false — as is its inverse.

23. (a) The path  $v \rightarrow v_1 \rightarrow v_2 \rightarrow v_3 \rightarrow \dots \rightarrow v_{n-1}$  provides a Hamilton path for  $H_n$ . Since  $\deg(v) = 1$  the graph cannot have a Hamilton cycle.

(b) Here  $|E| = \binom{n-1}{2} + 1$ . (So the number of edges required in Corollary 11.6 cannot be decreased.)

24. (a)

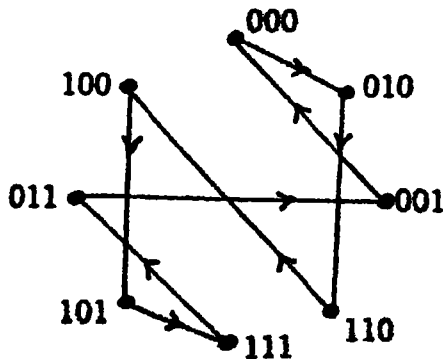

Since the given graph has a Hamilton path we use this path to provide the following Gray code for  $1, 2, 3, \dots, 8$ .

1: 000	2: 010	3: 110	4: 100
5: 101	6: 111	7: 011	8: 001

- (b)

1: 0000	2: 0001	3: 0011	4: 0111
5: 1111	6: 1110	7: 1100	8: 1000
9: 1010	10: 1011	11: 1001	12: 1101
13: 0101	14: 0100	15: 0110	16: 0010

25. (a) (i)  $\{a, c, f, h\}, \{a, g\}$ ; (ii)  $\{z\}, \{u, w, y\}$   
 (b) (i)  $\beta(G) = 4$ ; (ii)  $\beta(G) = 3$   
 (c) (i) 3 (ii) 3 (iii) 3 (iv) 4 (v) 6  
 (vi) The maximum of  $m$  and  $n$ .  
 (d) The complete graph on  $|I|$  vertices.
26. (a) If not, there is an edge  $\{a, b\}$  in  $E$  where  $a, b \in I$ . This contradicts the independence of  $I$ .  
 (b) A Hamilton cycle on  $v$  vertices must have  $v$  edges.  
 (c)

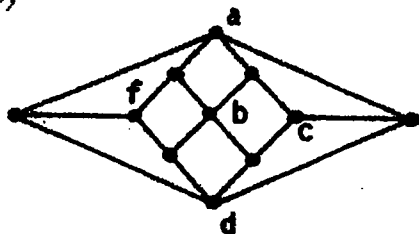

Let  $I = \{a, b, c, d, f\}$ , as shown in the figure. Here  $v = 11, e = 18$ , and  $e - \sum_{v \in I} \deg(v) + 2|I| = 18 - (4 + 4 + 3 + 4 + 3) + 2(5) = 10 < 11$ , so by part (b), the Herschel graph has no Hamilton cycle.

### Section 11.6

1. Draw a vertex for each species of fish. If two species  $x, y$  must be kept in separate aquaria, draw the edge  $\{x, y\}$ . The smallest number of aquaria needed is then the chromatic number of the resulting graph.
2. Draw a vertex for each committee. If someone serves on two committees  $c_i, c_j$  draw the edge joining the vertices for  $c_i$  and  $c_j$ . Then the least number of meeting times is the chromatic number of the graph.
3. We can model this problem with graphs. For either part of the problem draw the undirected graph  $G = (V, E)$  where  $V = \{1, 2, 3, 4, 5, 6, 7\}$  and  $\{i, j\} \in E$  when chemicals  $i$  and  $j$  require separate storage compartments. For part (a), the graph (in part (a) of the figure) has chromatic number 3, so here Jeannette will need three separate storage compartments to safely store these seven chemicals.

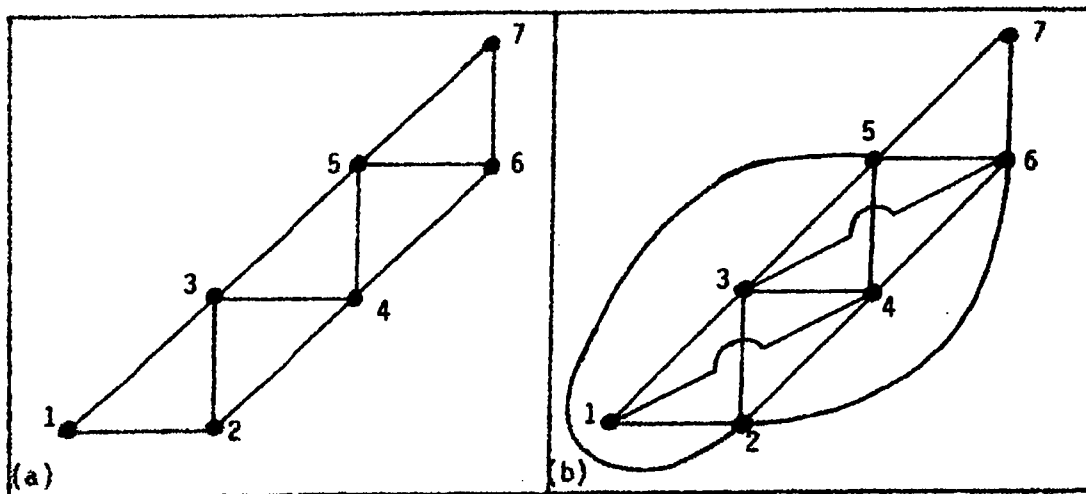

Now consider the graph in part (b) of the figure. Note here that the subgraph induced by the vertices 2,3,4,5,6 is (isomorphic to)  $K_5$ . Consequently, with these additional conditions Jeannette will need five separate storage compartments to store these seven chemicals safely.

4. Let  $G$  be a cycle on  $n$  vertices where  $n$  is odd and  $n \geq 5$ .

5. (a)  $P(G, \lambda) = \lambda(\lambda - 1)^3$

(b) For  $G = K_{1,n}$  we find that  $P(G, \lambda) = \lambda(\lambda - 1)^n$ .

$$\chi(K_{1,n}) = 2.$$

6. (a) (i) Here we have  $\lambda$  choices for vertex  $a$ , 1 choice for vertex  $b$  (the same choice as that for vertex  $a$ ), and  $\lambda - 1$  choices for each of vertices  $x, y, z$ . Consequently, there are  $\lambda(\lambda - 1)^3$  proper colorings of  $K_{2,3}$  where vertices  $a$  and  $b$  are colored the same.

(ii) Now we have  $\lambda$  choices for vertex  $a$ ,  $\lambda - 1$  choices for vertex  $b$ , and  $\lambda - 2$  choices for each of the vertices  $x, y$ , and  $z$ . And here there are  $\lambda(\lambda - 1)(\lambda - 2)^3$  proper colorings.

(b) Since the two cases in part (a) are exhaustive and mutually exclusive, the chromatic polynomial for  $K_{2,3}$  is

$$\lambda(\lambda - 1)^3 + \lambda(\lambda - 1)(\lambda - 2)^3 = \lambda(\lambda - 1)(\lambda^3 - 5\lambda^2 + 10\lambda - 7).$$

$$\chi(K_{2,3}) = 2.$$

(c)  $P(K_{2,n}, \lambda) = \lambda(\lambda - 1)^n + \lambda(\lambda - 1)(\lambda - 2)^n$

$$\chi(K_{2,n}) = 2.$$

7. (a) 2 (b) 2 ( $n$  even); 3 ( $n$  odd)

(c) Figure 11.59(d): 2; Fig. 11.62(a): 3; Fig. 11.85(i): 2; Fig. 11.85(ii): 3 (d) 2

8. If  $G = (V, E)$  is bipartite, then  $V = V_1 \cup V_2$  where  $V_1 \cap V_2 = \emptyset$  and each edge is of the form  $\{x, y\}$  where  $x \in V_1, y \in V_2$ . Color all the vertices in  $V_1$  with one color and those in  $V_2$  with a second color. Then  $\chi(G) = 2$ .

Conversely, if  $\chi(G) = 2$ , let  $V_1$  be the set of all vertices with one color and  $V_2$  the set of vertices with the second color. Then  $V = V_1 \cup V_2$  with  $V_1 \cap V_2 = \emptyset$  and each edge of  $G$  has one vertex in  $V_1$  and the other in  $V_2$ , so  $G$  is bipartite.

9. (a) (1)  $\lambda(\lambda - 1)^2(\lambda - 2)^2$ ; (2)  $\lambda(\lambda - 1)(\lambda - 2)(\lambda^2 - 2\lambda + 2)$ ;

(3)  $\lambda(\lambda - 1)(\lambda - 2)(\lambda^2 - 5\lambda + 7)$

(b) (1) 3; (2) 3; (3) 3

(c) (1) 720; (2) 1020; (3) 420

10. (a) These graphs are not isomorphic. The first graph has two vertices of degree 4 – namely,  $f$  and  $k$ . The second graph has three vertices of degree 4 – namely  $u, w, z$ .

(b) For the first graph there are two cases to consider.

Case (i): Vertices  $f$  and  $k$  have the same color: Here there are  $\lambda(\lambda - 1)^2(\lambda - 2)^2$  ways to properly color the vertices.

Case (ii): Vertices  $f$  and  $k$  are colored with different colors: Here the vertices can be properly colored in  $\lambda(\lambda - 1)(\lambda - 2)^2(\lambda - 3)^2$  ways.

By the rule of sum,  $P(G, \lambda) = \lambda(\lambda - 1)^2(\lambda - 2)^2 + \lambda(\lambda - 1)(\lambda - 2)^2(\lambda - 3)^2 = \lambda(\lambda - 1)^2(\lambda - 2)^2(\lambda^2 - 5\lambda + 8)$ .

Using the same type of argument, with the two cases for vertices  $u$  and  $z$ , the chromatic polynomial for the second graph is also found to be  $\lambda(\lambda - 1)^2(\lambda - 2)^2(\lambda^2 - 5\lambda + 8)$ .

(c) If  $G_1, G_2$  are two graphs with  $P(G_1, \lambda) = P(G_2, \lambda)$ , it need not be the case that  $G_1$  and  $G_2$  are isomorphic.

11. Let  $e = \{v, w\}$  be the deleted edge. There are  $\lambda(1)(\lambda - 1)(\lambda - 2) \cdots (\lambda - (n - 2))$  proper colorings of  $G_n$  where  $v, w$  share the same color and  $\lambda(\lambda - 1)(\lambda - 2) \cdots (\lambda - (n - 1))$  proper colorings where  $v, w$  are colored with different colors. In total there are  $P(G_n, \lambda) = \lambda(\lambda - 1) \cdots (\lambda - n + 2) + \lambda(\lambda - 1) \cdots (\lambda - n + 1) = \lambda(\lambda - 1) \cdots (\lambda - n + 3)(\lambda - n + 2)^2$  proper colorings for  $G_n$ .

Here  $\chi(G_n) = n - 1$ .

12. a) Here  $\binom{r}{2} + \binom{g}{2} = \binom{6}{2} + \binom{3}{2} = 15 + 3 = 18$ , and  $\binom{r+g}{2} = \binom{9}{2} = 36$ . So there are 18 edges that are red or green, and 18 blue edges.

b)  $\binom{r}{2} + \binom{g}{2} = (1/2)\binom{r+g}{2} \Leftrightarrow (1/2)r(r - 1) + (1/2)g(g - 1) = (1/4)(r + g)(r + g - 1) \Leftrightarrow 2r(r - 1) + 2g(g - 1) = (r + g)(r + g - 1) \Leftrightarrow r^2 - r + g^2 - g = 2rg \Leftrightarrow (r - g)^2 = r + g$ .

Let  $r = g + k, k \geq 0$ . Then  $[(r - g)^2 = k^2 = r + g = 2g + k] \Leftrightarrow [g = (1/2)(k^2 - k) = (1/2)k(k - 1) = t_{k-1}]$  and  $r = g + k = (1/2)k(k - 1) + k = (1/2)k[(k - 1) + 2k] = (1/2)k(k + 1) = t_k \Leftrightarrow r, g$  are two consecutive triangular numbers.

13. (a)  $|V| = 2n; |E| = (1/2) \sum_{v \in V} \deg(v) = (1/2)[4(2) + (2n - 4)(3)] = (1/2)[8 + 6n - 12] = 3n - 2, n \geq 1$ .

(b) For  $n = 1$ , we find that  $G = K_2$  and  $P(G, \lambda) = \lambda(\lambda - 1) = \lambda(\lambda - 1)(\lambda^2 - 3\lambda + 3)^{1-1}$  so the result is true in this first case. For  $n = 2$ , we have  $G = C_4$ , the cycle of length 4, and here  $P(G, \lambda) = \lambda(\lambda - 1)^3 - \lambda(\lambda - 1)(\lambda - 2) = \lambda(\lambda - 1)(\lambda^2 - 3\lambda + 3)^{2-1}$ . So the result follows for  $n = 2$ . Assuming the result true for an arbitrary (but fixed)  $n \geq 1$ , consider the situation for  $n + 1$ . Write  $G = G_1 \cup G_2$ , where  $G_1$  is  $C_4$  and  $G_2$  is the ladder graph for  $n$  rungs. Then  $G_1 \cap G_2 = K_2$ , so from Theorem 11.14 we have  $P(G, \lambda) = P(G_1, \lambda) \cdot P(G_2, \lambda) / P(K_2, \lambda) = [(\lambda)(\lambda - 1)(\lambda^2 - 3\lambda + 3)][(\lambda)(\lambda - 1)(\lambda^2 - 3\lambda + 3)^{n-1}] / (\lambda)(\lambda - 1) = (\lambda)(\lambda - 1)(\lambda^2 - 3\lambda + 3)^n$ . Consequently, the result is true for all  $n \geq 1$ , by the Principle of Mathematical Induction.

14. (a) Select a vertex  $v \in V$  and color it with one of the  $\Delta + 1$  available colors. If  $w \in V$  and  $w$  has not been colored, since  $\deg(w) \leq \Delta$  we can color  $w$ , not using any of the colors used on the vertices adjacent to  $w$ . This procedure is repeated until all of the

vertices in  $V$  have been (properly) colored.

(b) For  $n \in \mathbb{Z}^+$ ,  $n \geq 3$ ,  $\chi(K_n) = n = \Delta + 1$ .

15. (a)  $\lambda(\lambda - 1)(\lambda - 2)$  (b) Follows from Theorem 11.10

(c) Follows by the rule of product.

(d)

$$\begin{aligned} P(C_n, \lambda) &= P(P_{n-1}, \lambda) - P(C_{n-1}, \lambda) = \lambda(\lambda - 1)^{n-1} - P(C_{n-1}, \lambda) \\ &= [(\lambda - 1) + 1](\lambda - 1)^{n-1} - P(C_{n-1}, \lambda) \\ &= (\lambda - 1)^n + (\lambda - 1)^{n-1} - P(C_{n-1}, \lambda) \implies \\ &P(C_n, \lambda) - (\lambda - 1)^n = (\lambda - 1)^{n-1} - P(C_{n-1}, \lambda). \end{aligned}$$

Replacing  $n$  by  $n - 1$  yields

$$P(C_{n-1}, \lambda) - (\lambda - 1)^{n-1} = (\lambda - 1)^{n-2} - P(C_{n-2}, \lambda) = (-1)[P(C_{n-2}, \lambda) - (\lambda - 1)^{n-2}].$$

Hence

$$P(C_n, \lambda) - (\lambda - 1)^n = P(C_{n-2}, \lambda) - (\lambda - 1)^{n-2} = (-1)^2[P(C_{n-2}, \lambda) - (\lambda - 1)^{n-2}].$$

(e) Continuing from part (d),

$$\begin{aligned} P(C_n, \lambda) &= (\lambda - 1)^n + (-1)^{n-3}[P(C_3, \lambda) - (\lambda - 1)^3] \\ &= (\lambda - 1)^n + (-1)^{n-1}[\lambda(\lambda - 1)(\lambda - 2) - (\lambda - 1)^3] \\ &= (\lambda - 1)^n + (-1)^n(\lambda - 1). \end{aligned}$$

16. (a)  $\chi(W_n) = \chi(C_n) + 1$ . [ $C_n$  has  $n$  vertices;  $W_n$  has  $n + 1$  vertices.]

(b)  $P(W_n, \lambda) = \lambda P(C_n, \lambda - 1) = \lambda[(\lambda - 2)^n + (-1)^n(\lambda - 2)]$ .

(c) (i) and (ii)  $P(W_5, \lambda) = \lambda(\lambda - 2)^5 + (-1)^5\lambda(\lambda - 2)$  - For  $k$  colors we have  $P(W_5, k) = k(k - 2)^5 + (-1)^5k(k - 2) = k(k - 2)[(k - 2)^4 - 1]$  proper colorings, whenever  $k \geq 4$ .

17. From Theorem 11.13, the expansion for  $P(G, \lambda)$  will contain exactly one occurrence of the chromatic polynomial of  $K_n$ . Since no larger graph occurs this term determines the degree as  $n$  and the leading coefficient as 1.

18. (a)

$$\begin{array}{ll} |V| = 1: & P(G, \lambda) = \lambda \\ |V| = 2: & |E| = 0: \quad P(G, \lambda) = \lambda^2 \\ & |E| = 1: \quad P(G, \lambda) = \lambda(\lambda - 1) = \lambda^2 - \lambda \\ |V| = 3: & |E| = 0: \quad P(G, \lambda) = \lambda^3 \\ & |E| = 1: \quad P(G, \lambda) = \lambda^2(\lambda - 1) = \lambda^3 - \lambda^2 \\ & |E| = 2: \quad P(G, \lambda) = \lambda(\lambda - 1)^2 = \lambda^3 - 2\lambda^2 + \lambda \\ & |E| = 3: \quad P(G, \lambda) = \lambda(\lambda - 1)(\lambda - 2) = \lambda^3 - 3\lambda^2 + 2\lambda \end{array}$$

(b) Let  $G = (V, E)$  be a loop-free undirected graph where  $|V| = n \geq 4$  and  $|E| = k \geq 1$ . (If  $k = 0$ ,  $P(G, \lambda) = \lambda^n$  and the result is true.) From Theorem 11.10,  $P(G, \lambda) = P(G_e, \lambda) - P(G'_e, \lambda)$  where  $e = \{a, b\}$  is an edge in  $G$ . Since  $G_e$  has  $n$  vertices but  $k - 1$  edges, by the induction hypothesis,

$$P(G_e, \lambda) = \lambda^n - (k - 1)\lambda^{n-1} + c_{n-2}\lambda^{n-2} - c_{n-3}\lambda^{n-3} + \dots + (-1)^{n-1}c_1\lambda,$$

where  $k - 1, c_{n-2}, c_{n-3}, \dots, c_1 \geq 0$ . (When a coefficient in this list is zero, all successive coefficients are zero.) Likewise, since  $G'_e$  has  $n - 1$  vertices, by the induction hypothesis,

$$P(G'_e, \lambda) = \lambda^{n-1} - b_{n-2}\lambda^{n-2} + b_{n-3}\lambda^{n-3} - \dots + (-1)^{n-2}b_1\lambda,$$

where  $b_{n-2}, b_{n-3}, \dots, b_1 \geq 0$ .

Then  $P(G, \lambda) = P(G_e, \lambda) - P(G'_e, \lambda) =$

$$\lambda^n - (k)\lambda^{n-1} + (c_{n-2} + b_{n-2})\lambda^{n-2} + \dots + (-1)^{n-1}(c_1 + b_1)\lambda.$$

(c) This was shown in part (b).

19. (a) For  $n \in \mathbb{Z}^+$ ,  $n \geq 3$ , let  $C_n$  denote the cycle on  $n$  vertices.

If  $n$  is odd then  $\chi(C_n) = 3$ . But for each  $v$  in  $C_n$ , the subgraph  $C_n - v$  is a path with  $n - 1$  vertices and  $\chi(C_n - v) = 2$ . So for  $n$  odd  $C_n$  is color-critical.

However, when  $n$  is even we have  $\chi(C_n) = 2$ , and for each  $v$  in  $C_n$ , the subgraph  $C_n - v$  is still a path with  $n - 1$  vertices and  $\chi(C_n - v) = 2$ . Consequently, cycles with an even number of vertices are not color-critical.

(b) For every complete graph  $K_n$ , where  $n \geq 2$ , we have  $\chi(K_n) = n$ , and for each vertex  $v$  in  $K_n$ ,  $K_n - v$  is (isomorphic to)  $K_{n-1}$ , so  $\chi(K_n - v) = n - 1$ . Consequently, every complete graph with at least one edge is color-critical.

(c) Suppose that  $G$  is not connected. Let  $G_1$  be a component of  $G$  where  $\chi(G_1) = \chi(G)$ , and let  $G_2$  be any other component of  $G$ . Then  $\chi(G_1) \geq \chi(G_2)$  and for all  $v$  in  $G_2$  we find that  $\chi(G - v) = \chi(G_1) = \chi(G)$ , so  $G$  is not color-critical.

(d) If not, let  $v \in V$  with  $\deg(v) \leq k - 2$ . Since  $G$  is color-critical we have  $\chi(G - v) \leq k - 1$ , and so we can properly color the vertices in the subgraph  $G - v$  with at most  $k - 1$  colors. Since  $\deg(v) \leq k - 2$ , we have used at most  $k - 2$  colors to color all vertices in  $G$  adjacent to  $v$ . Therefore we do not need a new color (beyond those needed to color the subgraph  $G - v$ ) in order to color  $v$  and can color all vertices in  $G$  with at most  $k - 1$  colors. But this contradicts  $\chi(G) = k$ .

## Supplementary Exercises

- $\binom{n}{2} = 56 + 80 = 136 \implies n(n-1) = 272 \implies n = 17$ .
- For  $n \geq 1$ , let  $c_n$  count the number of cycles of length four in  $Q_n$ . Then  $c_1 = 0$  and  $c_2 = 1$ . Recall the recursive construction of  $Q_{n+1}$  from  $Q_n$  — given in Section 11.3. Let  $V_{n+1}^{(0)}$  denote all the vertices in  $Q_{n+1}$  that start with 0, and  $V_{n+1}^{(1)}$  those vertices in  $Q_{n+1}$  that start with 1. [Each of the subgraphs of  $Q_{n+1}$  induced by  $V_{n+1}^{(0)}$  and  $V_{n+1}^{(1)}$  is isomorphic to  $Q_n$ .] Let  $v_1 \rightarrow v_2 \rightarrow v_3 \rightarrow v_4 \rightarrow v_1$  denote a cycle of length four in  $Q_{n+1}$ . There are three cases to consider:
  - $v_1, v_2, v_3, v_4 \in V_{n+1}^{(0)}$ : Here there are  $c_n$  such cycles;
  - $v_1, v_2, v_3, v_4 \in V_{n+1}^{(1)}$ : Here there are also  $c_n$  such cycles; and,
  - one edge of the cycle (call it the first) is in  $\langle V_{n+1}^{(0)} \rangle$  and another edge (namely, the third) is in  $\langle V_{n+1}^{(1)} \rangle$ : Here the other two edges are each adjacent to a vertex in  $V_{n+1}^{(0)}$  and one in  $V_{n+1}^{(1)}$ . [Let  $\{v_1, v_2\} \in \langle V_{n+1}^{(0)} \rangle$ , then  $\{v_3, v_4\} \in \langle V_{n+1}^{(1)} \rangle$  and the binary labels on  $v_1$  and  $v_4$  differ only in the first (left-most) position, while the binary labels on  $v_2$  and  $v_3$  also differ only in the first (left-most) position.] Since there are  $n2^{n-1}$  possible choices (the number of edges in  $Q_n$ ) for the so called “first” edge, here we find  $n2^{n-1}$  new cycles of length four.

The preceding discussion gives us

$$c_{n+1} = 2c_n + n2^{n-1} = 2c_n + (1/2)n2^n \quad n \geq 1, \quad c_1 = 0, \quad c_2 = 1.$$

$$c_n^{(h)} = A2^n, \quad c_n^{(p)} = n(B + Cn)2^n$$

$$(n+1)(B + C(n+1))2^{n+1} = 2n(B + Cn)2^n + n2^{n-1}$$

$$\implies [B(n+1) + C(n+1)^2]2^{n+1} = [Bn + Cn^2]2^{n+1} + (n/4)2^{n+1}$$

$$\implies 2C = 1/4, \quad B + C = 0 \implies C = 1/8, \quad B = -1/8.$$

$$\text{So } c_n^{(p)} = (1/8)(n^2 - n)2^n.$$

$$0 = c_1 = c_1^{(h)} + c_1^{(p)} = 2A + 0 \implies A = 0, \text{ so}$$

$$c_n = (1/8)(n^2 - n)2^n = \binom{n}{2}2^{n-2}, \quad n \geq 1.$$

Alternate Solution: Let  $v_1 \rightarrow v_2 \rightarrow v_3 \rightarrow v_4 \rightarrow v_1$  be a cycle of length four in  $Q_n$ . Say  $v_1, v_2$  differ in position  $i$  and  $v_2, v_4$  differ in position  $j$ , where  $1 \leq i \leq n$ ,  $1 \leq j \leq n$ , and  $i \neq j$ . Then  $v_3$  is determined: it differs from  $v_1$  in positions  $i$  and  $j$ . Starting with  $v_1$  there are  $2^n$  choices. Then for a specific  $v_1$  there are  $\binom{n}{2}$  ways to select positions  $i, j$ . [Remember that  $v_1 \rightarrow v_4 \rightarrow v_3 \rightarrow v_2 \rightarrow v_1$  is the same cycle as  $v_1 \rightarrow v_2 \rightarrow v_3 \rightarrow v_4 \rightarrow v_1$ .] So at this point we have  $\binom{n}{2}2^n$  cycles. But since each of  $v_2 \rightarrow v_3 \rightarrow v_4 \rightarrow v_1 \rightarrow v_2$ ,  $v_3 \rightarrow v_4 \rightarrow v_1 \rightarrow v_2 \rightarrow v_3$ , and  $v_4 \rightarrow v_1 \rightarrow v_2 \rightarrow v_3 \rightarrow v_4$  is the same cycle as  $v_1 \rightarrow v_2 \rightarrow v_3 \rightarrow v_4 \rightarrow v_1$ , the total number of *distinct* cycles of length four in  $Q_n$  is  $(1/4)\binom{n}{2}2^n = \binom{n}{2}2^{n-2}$ ,  $n \geq 1$ .

- (a) Label the vertices of  $K_6$  with  $a, b, \dots, f$ . Of the five edges on  $a$  at least three have the same color, say red, and let these edges be  $\{a, b\}, \{a, c\}, \{a, d\}$ . If the edges  $\{b, c\}, \{c, d\}, \{b, d\}$  are all blue, the result follows. If not, one of these edges, say  $\{c, d\}$ , is red and then  $\{a, c\}, \{a, d\}, \{c, d\}$  yield a red triangle.

(b) Consider the six people as vertices. If two people are friends (strangers) draw a red (blue) edge connecting their respective vertices. The result then follows from part (a).

4. (a) (i)  $|E| = (1/2)\binom{n}{2}$

(ii) For any undirected graph  $G$ , if  $G$  is not connected then  $\bar{G}$  is connected. In this situation  $G \cong \bar{G}$ , so  $G$  is connected.

(b) Proof: When  $n = 1$  we have  $K_1$ . For  $n = 4$  the path on four vertices is an example of a self-complementary graph. The cycle on five vertices provides an example for  $n = 5$ .

Now suppose we have a self-complementary graph  $G = (V, E)$ . Construct the graph  $G_1 = (V_1, E_1)$  where  $V_1 = V \cup \{a, b, c, d\}$  (so none of  $a, b, c, d$  is in  $V$ ) and  $E_1 = E \cup \{\{a, b\}, \{b, c\}, \{c, d\}\} \cup \{\{v, a\} | v \in V\} \cup \{\{v, d\} | v \in V\}$ . Then  $G_1$  is self-complementary and  $|V_1| = |V| + 4$ .

5. (a) We can redraw  $G_2$  as

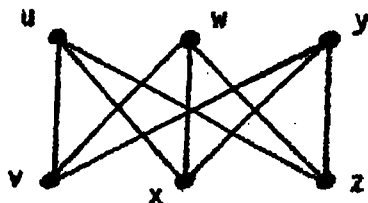

(b) 72

6. Only the graph for the cube is bipartite as seen in part (b) of the given figure. In any of the other four graphs (See Fig. 11.59(b) and Fig. 11.60) there are cycles of odd length, so these graphs cannot be bipartite.

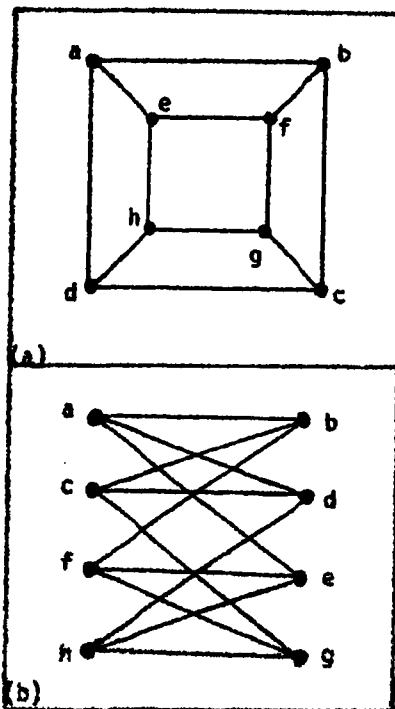

7. (a) Let the vertices of  $K_{3,7}$  be partitioned as  $V_1 \cup V_2$  where  $|V_1| = 3$  and  $|V_2| = 7$ . Then there are  $(3)(7)(2)(6)(1)(5) = 1260$  paths of length 5 where each such path contains all three vertices in  $V_1$ .

(b) With  $V_1, V_2$  as in part (a) we find that there are  $(1/2)(3)(7)(2)(6)(1)$  paths of length 4 that start and end with a vertex in  $V_1$ , and there are also  $(1/2)(7)(3)(6)(2)(5)$  paths of length 4 that start and end with a vertex in  $V_2$ . Consequently, there are  $126 + 630 = 756$  paths of length 4 in  $K_{3,7}$ .

(c) (Case 1:  $p$  is odd,  $p = 2k + 1$  for  $k \in \mathbb{N}$ ). Here there are  $mn$  paths of length  $p = 1$  (when  $k = 0$ ) and  $(m)(n)(m-1)(n-1) \cdots (m-k)(n-k)$  paths of length  $p = 2k + 1 \geq 3$ . (Case 2:  $p$  is even,  $p = 2k$  for  $k \in \mathbb{Z}^+$ ). When  $p < 2m$  (i.e.,  $k < m$ ) the number of paths of length  $p$  is  $(1/2)(m)(n)(m-1)(n-1) \cdots (n-(k-1))(m-k) + (1/2)(n)(m)(n-1)(m-1) \cdots (m-(k-1))(n-k)$ . For  $p = 2m$  we find  $(1/2)(n)(m)(n-1)(m-1) \cdots (m-(m-1))(n-m)$  paths of (longest) length  $2m$ .

8. (a) ( $n = 2$ ):  $X = \{1, 2\}$  and  $G$  consists of the single vertex  $v$  that corresponds to  $X$ .  
 ( $n = 3$ ):  $X = \{1, 2, 3\}$ . Here  $G$  is made up of three isolated vertices.  
 ( $n = 4$ ):  $X = \{1, 2, 3, 4\}$ . Now  $G$  has six vertices and is drawn as follows:

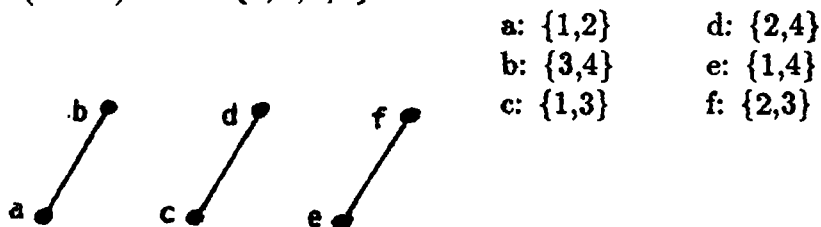

(b) Let  $v(\{a, b\})$  and  $w(\{x, y\})$  be two vertices of  $G$ . If  $\{a, b\} \cap \{x, y\} = \emptyset$ , the edge  $\{v, w\}$  is in  $G$ . If  $\{a, b\} \cap \{x, y\} \neq \emptyset$ , assume without loss of generality that  $a = x$  but  $b \neq y$ . Hence  $a, b, y$  are three distinct elements of  $X$  and since  $|X| \geq 5$ , let  $c, d \in X$  with  $c \neq d$  and  $c, d \notin \{a, b, y\}$ . Then there exist edges from  $\{a, b\}$  to  $\{c, d\}$  and from  $\{c, d\}$  to  $\{x(=a), y\}$ , since  $\{a, b\} \cap \{c, d\} = \emptyset = \{c, d\} \cap \{x, y\}$ . Hence  $G$  is connected.

(c) For  $n = 5$   $G$  is (isomorphic to) the Petersen graph, which is nonplanar. For  $n \geq 6$   $G$  contains a subgraph isomorphic to the Petersen graph and consequently  $G$  is nonplanar.

9. (a) Let  $I$  be independent and  $\{a, b\} \in E$ . If neither  $a$  nor  $b$  is in  $V - I$ , then  $a, b \in I$ , and since they are adjacent,  $I$  is not independent. Conversely, if  $I \subseteq V$  with  $V - I$  a covering of  $G$ , then if  $I$  is not independent there are vertices  $x, y \in I$  with  $\{x, y\} \in E$ . But  $\{x, y\} \in E \implies$  either  $x$  or  $y$  is in  $V - I$ .

(b) Let  $I$  be a largest maximal independent set in  $G$  and  $K$  a minimal covering. From part (a),  $|K| \leq |V - I| = |V| - |I|$  and  $|I| \geq |V - K| = |V| - |K|$ , or  $|K| + |I| \geq |V| \geq |K| + |I|$ .

10. (a) Let  $D$  be a minimal dominating set for  $G$ . If  $V - D$  is not dominating, then there is a vertex  $x \in D$  such that  $x$  is not adjacent to any vertex in  $V - D$ . Since  $G$  has no isolated vertices,  $x$  is adjacent to at least one vertex in  $D - \{x\}$  and  $D - \{x\}$  is a dominating set, contradicting the minimality of  $D$ .

(b) Suppose that  $I$  is a dominating set. If  $I$  is independent but not maximal independent, then there is a vertex  $v \in V$  such that  $v$  is not in  $I$  and is not adjacent to any vertex in  $I$ . But this contradicts  $I$  being a dominating set. Conversely, if  $I$  is maximal independent then every vertex in  $V$  is in  $I$  or is adjacent to a vertex in  $I$ . Hence  $I$  is dominating.

(c)  $\gamma(G) \leq \beta(G)$  follows from part (b). For the other condition, let  $\chi(G) = m$ . We can partition the vertices of  $G$  into  $m$  cells  $V_i$ ,  $1 \leq i \leq m$ , where two vertices are in the same cell if they have the same color in  $G$ . Each of these cells is an independent set so  $|V_i| \leq \beta(G)$ , for all  $1 \leq i \leq m$ . Since  $|V| = \sum_{i=1}^m |V_i|$ ,  $|V| \leq \sum_{i=1}^m \beta(G) = m\beta(G) = \beta(G)\chi(G)$ .

11. Since we are selecting  $n$  edges and no two have a common vertex, the selection of  $n$  edges will include exactly one occurrence of every vertex. We consider two mutually disjoint and exhaustive cases:

(1) The edge  $\{x_n, y_n\}$  is in the selection: Then  $\{x_{n-1}, x_n\}$  and  $\{y_{n-1}, y_n\}$  are not in the selection and we must select the remaining  $n - 1$  edges from the resulting subgraph (a ladder graph with  $n - 1$  rungs) in  $a_{n-1}$  ways.

(2) The edge  $\{x_n, y_n\}$  is not in the selection: Then in order to have  $x_n$  and  $y_n$  appear in the selection we must include edges  $\{x_{n-1}, x_n\}$  and  $\{y_{n-1}, y_n\}$ . Consequently, we must now select the other  $n - 2$  edges from the resulting subgraph (a ladder graph with  $n - 2$  rungs) in  $a_{n-2}$  ways.

Hence  $a_n = a_{n-1} + a_{n-2}$ ,  $a_0 = 1$ ,  $a_1 = 1$ , and  $a_n = F_{n+1}$ , the  $(n + 1)$ st Fibonacci number.

12. There are two cases to consider:

(1) The vertex  $y_n$  is not used. Then there are  $a_{n-1}$  independent subsets that contain  $x_n$ , and another  $a_{n-1}$  such subsets that do not contain  $x_n$ .

(2) The vertex  $y_n$  is included in the independent subset. Now we cannot use either of the vertices  $x_n$  or  $y_{n-1}$ . Consequently, there are  $a_{n-2}$  such subsets for each of the following situations: (i)  $x_{n-1}$  is in the subset; and (ii)  $x_{n-1}$  is not in the subset.

These considerations give rise to the recurrence relation

$$a_n = 2a_{n-1} + 2a_{n-2},$$

with initial conditions  $a_0 = 1$ ,  $a_1 = 3$ . (We used  $a_2 = 8$  to determine  $a_0 = 1$ .)

To solve this recurrence relation let  $a_n = Ar^n$ , where  $A \neq 0$ ,  $r \neq 0$ . This leads to the characteristic equation

$$r^2 - 2r - 2 = 0,$$

and the characteristic roots  $1 \pm \sqrt{3}$ . Consequently,  $a_n = A_1(1 + \sqrt{3})^n + A_2(1 - \sqrt{3})^n$ , where  $A_1, A_2$  are constants.

$$1 = a_0 = A_1 + A_2$$

$$3 = a_1 = A_1(1 + \sqrt{3}) + A_2(1 - \sqrt{3}) = (A_1 + A_2) + \sqrt{3}(A_1 - A_2)$$

$= 1 + \sqrt{3}(A_1 - A_2)$ , so  $2/\sqrt{3} = (A_1 - A_2)$ .

Therefore,  $A_1 = (\sqrt{3} + 2)/2\sqrt{3}$ ,  $A_2 = (\sqrt{3} - 2)/2\sqrt{3}$ , and

$a_n = [(\sqrt{3} + 2)/2\sqrt{3}](1 + \sqrt{3})^n + [(\sqrt{3} - 2)/2\sqrt{3}](1 - \sqrt{3})^n$ ,  $n \geq 0$  (or  $n \geq 1$ ).

13. If the vertex  $y_n$  is included in the independent subset then we cannot use any of the vertices  $y_{n-1}$ ,  $x_{n-1}$ , or  $x_n$ . There are  $a_{n-2}$  such subsets — and another  $a_{n-2}$  independent subsets where  $x_n$  is included. In addition, there are  $a_{n-1}$  independent subsets when both  $x_n$  and  $y_n$  are excluded. This leads us to the recurrence relation

$$a_n = a_{n-1} + 2a_{n-2},$$

with initial conditions  $a_1 = 3$ ,  $a_2 = 5$ .

To solve this recurrence relation let  $a_n = Ar^n$ , where  $A \neq 0$ ,  $r \neq 0$ . This leads to the characteristic equation

$$r^2 - r - 2 = 0,$$

and the characteristic roots  $-1$  and  $2$ . Therefore,  $a_n = A_1(-1)^n + A_2(2^n)$ , where  $A_1, A_2$  are constants.

$$a_1 = 3, a_2 = 5 \Rightarrow 2a_0 = 5 - 3 \Rightarrow a_0 = 1.$$

$$1 = a_0 = A_1 + A_2.$$

$$3 = a_1 = -A_1 + 2A_2 = -(1 - A_2) + 2A_2 = -1 + 3A_2, \text{ so } A_2 = 4/3, \text{ and } A_1 = 1 - A_2 = -1/3.$$

Consequently,  $a_n = (-1/3)(-1)^n + (4/3)(2^n)$ ,  $n \geq 0$  (or  $n \geq 1$ ).

14.  $a_0 = a_1 = 0$

For  $n \geq 2$ ,  $a_n = \binom{n}{2} = (1/2)n(n-1) > 0$ .

$$1/(1-x) = 1 + x + x^2 + x^3 + \dots$$

$$(d/dx)[1/(1-x)] = 1 + 2x + 3x^2 + 4x^3 + \dots$$

$$(d/dx)[1/(1-x)] = (d/dx)[(1-x)^{-1}] = (-1)(1-x)^{-2}(-1) = (1-x)^{-2}$$

$$(1-x)^{-2} = 1 + 2x + 3x^2 + 4x^3 + \dots$$

$$(d/dx)[(1-x)^{-2}] = (-2)(1-x)^{-3}(-1) = 2(1-x)^{-3}, \text{ so } 2(1-x)^{-3} = 2 + 3 \cdot 2x + 4 \cdot 3x^2 + 5 \cdot 4x^3 + \dots$$

$$2x^2/(1-x)^3 = 2 \cdot 1x^2 + 3 \cdot 2x^3 + 4 \cdot 3x^4 + 5 \cdot 4x^5 + \dots = \sum_{n=2}^{\infty} n(n-1)x^n = \sum_{n=0}^{\infty} n(n-1)x^n$$

Hence  $f(x) = x^2/(1-x)^3 = \sum_{n=0}^{\infty} [n(n-1)/2]x^n$  is the generating function for the sequence  $a_n = \binom{n}{2}$ ,  $n \geq 0$ .

15. (a)  $\gamma(G) = 2$ ;  $\beta(G) = 3$ ;  $\chi(G) = 4$ .

(b)  $G$  has neither an Euler trail nor an Euler circuit;  $G$  does have a Hamilton cycle.

(c)  $G$  is not bipartite but it is planar.

16. (a) (i)  $m = 2$ ,  $n = 8$                       (ii)  $m = n = 4$

(b) (i)  $K_{m,n}$ , for  $m \leq n$ , has an Euler circuit but not a Hamilton cycle if  $m$  and  $n$  are both even and  $m \neq n$ .

(ii) When  $m, n$  are both even and  $m = n$ , then  $K_{m,n}$  has both an Euler circuit and a Hamilton cycle.

17. (a)  $\chi(G) \geq \omega(G)$  (b) They are equal.

18. (a) (i) Here vertex 1 is for edge  $\{a, c\}$ , 2 for  $\{a, b\}$ , 3 for  $\{b, c\}$ , and 4 for  $\{c, d\}$ .

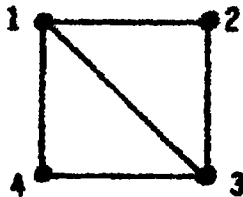

(ii) Here the correspondence between vertices in  $L(G)$  and edges in  $G$  is given by

- 1:  $\{y, z\}$ ; 2:  $\{x, z\}$ ; 3:  $\{w, x\}$ ;  
 4:  $\{w, y\}$ ; 5:  $\{u, y\}$ ; 6:  $\{u, x\}$

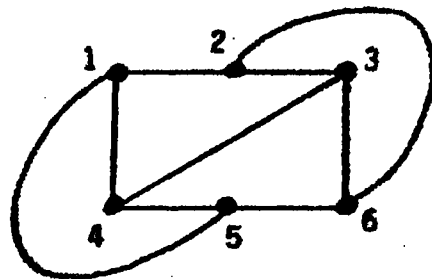

(b) Let  $v \in V$  with  $\deg(v) = k$ . Then there are  $k$  edges in  $G$  of the form  $\{v_i, v\}$ ,  $1 \leq i \leq k$ . Any two of these edges are adjacent at  $v$  and give rise to an edge in  $L(G)$ . Hence  $v$  brings about  $\binom{\deg(v)}{2}$  edges in  $L(G)$ . In total,  $L(G)$  has  $\sum_{v \in V} \binom{\deg(v)}{2} = (1/2) \sum_{v \in V} \deg(v)[\deg(v) - 1] = (1/2) \sum_{v \in V} \deg(v)^2 - (1/2) \sum_{v \in V} \deg(v) = (1/2) \sum_{v \in V} \deg(v)^2 - e$  edges.

(c) First we shall prove that  $L(G)$  is connected. Let  $e_1, e_2$  be two vertices in  $L(G)$  where  $e_1$  arises from edge  $\{a, b\}$  and  $e_2$  from edge  $\{x, y\}$  in  $G$ . Since  $G$  is connected there is a path in  $G$  from  $b$  to  $x$ :  $b \rightarrow v_1 \rightarrow v_2 \rightarrow \dots \rightarrow v_k \rightarrow x$  and a path from  $a$  to  $y$ :  $a \rightarrow b \rightarrow v_1 \rightarrow \dots \rightarrow v_k \rightarrow x \rightarrow y$ . These vertices and edges then determine a path in  $L(G)$  from  $e_1$  to  $e_2$ , so  $L(G)$  is connected. Now for any vertex  $e$  in  $L(G)$ , let  $\{a, b\}$  be the edge in  $G$  that determines  $e$ . Then  $\deg(e)$  (in  $L(G)$ )  $= (\deg(a) - 1) + (\deg(b) - 1)$ , an even integer, since  $\deg(a), \deg(b)$  are both even. Hence by Theorem 11.3,  $L(G)$  has an Euler circuit. Furthermore, the ordered list of edges in an Euler circuit for  $G$  determine a corresponding Hamilton cycle for the vertices of  $L(G)$ .

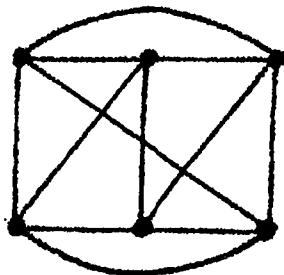

(d) For  $G = K_4$ ,  $L(K_4)$  is shown here. This graph has both an Euler circuit and a Hamilton cycle. However, for each vertex  $v$  in  $K_4$ ,  $\deg(v) = 3$ , so  $K_4$  does not have an Euler circuit.

(e) Suppose that  $G = (V, E)$  has a Hamilton cycle  $v_1 \rightarrow v_2 \rightarrow v_3 \rightarrow \dots \rightarrow v_n \rightarrow v_1$  and let  $e_i = \{v_i, v_{i+1}\}$ ,  $1 \leq i \leq n-1$ , and  $e_n = \{v_n, v_1\}$ . Then there is a cycle in  $L(G)$  on the vertices  $e_i$ ,  $1 \leq i \leq n$ . If  $|E| = n$ , then this cycle is a Hamilton cycle. If  $|E| > n$ , let  $e \in E$ , where  $e \neq e_i$ ,  $1 \leq i \leq n$ , and let  $e = \{v_i, v_j\}$ ,  $1 \leq i < j \leq n$ . (This also takes care of the case where  $G$  is a multigraph.) In  $L(G)$  there are edges  $\{e_{i-1}, e\}$ , where  $e_{i-1} = e_n$  if  $i = 1$ , and  $\{e, e_i\}$ , and we can extend the cycle in  $L(G)$  by replacing  $\{e_{i-1}, e_i\}$  by the edges  $\{e_{i-1}, e\}$  and  $\{e, e_i\}$ . Since  $|E|$  is finite, as we continue enlarging our present cycle in this way, we obtain a Hamilton cycle for  $L(G)$ .

(f) The graph in Fig. 11.99(b) has no Hamilton cycle, but its line graph, as seen in part (a), has a Hamilton cycle.

(g) For  $G = K_5$ ,  $L(G)$  has 10 vertices and 30 edges. Since  $G$  is connected,  $L(G)$  is connected. But since  $30 > 3(10) - 6$ , it follows by Corollary 11.3 that  $L(G)$  is nonplanar.

For  $G = K_{3,3}$  we number the edges as shown in the first figure. Then in  $L(G)$  we find the subgraph shown in the second figure, so  $L(G)$  is nonplanar.

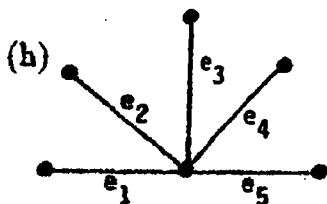
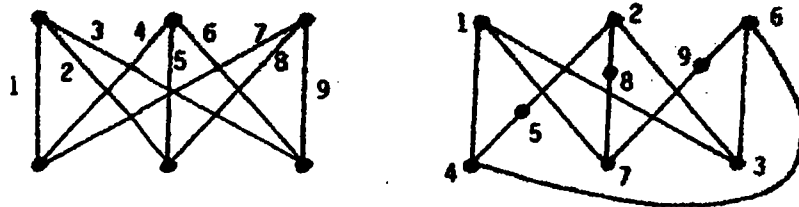

Let  $G$  be the graph shown here with six vertices (five pendant and one of degree 5). Then in  $L(G)$  there are five vertices each of degree four, and  $L(G) = K_5$ , a nonplanar graph.

19. (a) The constant term is 3, not 0. This contradicts Theorem 11.11.  
 (b) The leading coefficient is 3, not 1. This contradicts the result in Exercise 17 of Section 11.6.  
 (c) The sum of the coefficients is -1, not 0. This contradicts Theorem 11.12.

20. (a)  $x^3y - xy^3 = xy(x^2 - y^2) = xy(x - y)(x + y)$   
 If  $x$  or  $y$  is even then  $xy$  and  $xy(x - y)(x + y)$  are both even. When  $x, y$  are both odd, then  $x - y$  and  $x + y$  are both even, as is  $xy(x - y)(x + y)$ .

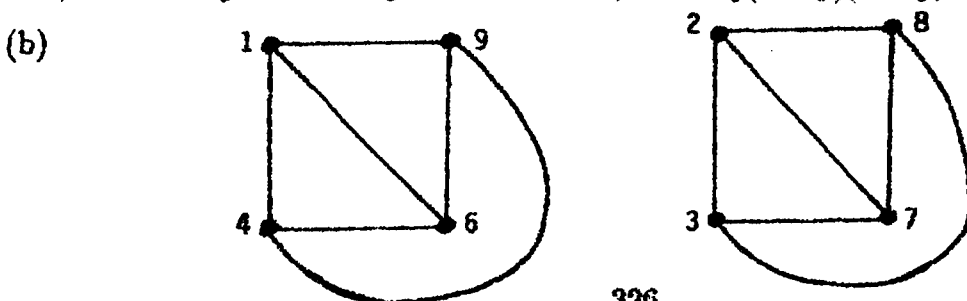

(c) From part (a)  $x^3y - xy^3 = xy(x-y)(x+y)$  is always even. If the units digit of either  $x$  or  $y$  is 0 or 5, then the result follows. Also, if  $x, y$  have the same units digit, then  $x - y$  is a multiple of 10 and so is  $x^3y - xy^3$ . In all other cases we have three positive integers  $x, y, z$  with distinct units digits in the set  $V = \{1, 2, 3, 4, 6, 7, 8, 9\}$ . By the pigeonhole principle two of these integers, say  $x$  and  $y$ , must be in the same component ( $K_4$ ) of  $G$ . Since the component is complete,  $\{x, y\}$  is an edge, so either  $x + y$  or  $x - y$  is divisible by 5. Hence  $x^3y - xy^3$  is divisible by 10.

21. (a)  $a_1 = 2, a_2 = 3$ . For  $n \geq 3$  label the vertices of  $P_n$  as  $v_1, v_2, v_3, \dots, v_n$  where the edges are  $\{v_1, v_2\}, \{v_2, v_3\}, \dots, \{v_{n-1}, v_n\}$ . In constructing an independent subset  $S$  from  $P_n$  we consider two cases:

(1)  $v_n \notin S$ : Then  $S$  is an independent subset of  $P_{n-1}$  and there are  $a_{n-1}$  such subsets.

(2)  $v_n \in S$ : Then  $v_{n-1} \notin S$  and  $S - \{v_n\}$  is one of the  $a_{n-2}$  independent subsets of  $P_{n-2}$ .

Hence  $a_n = a_{n-1} + a_{n-2}, n \geq 3, a_1 = 2, a_2 = 3$ , or  $a_n = a_{n-1} + a_{n-2}, n \geq 2, a_0 = 1, a_1 = 2$ . So  $a_n = F_{n+2}$ , the  $(n+2)$ nd Fibonacci number.

(b) Consider the subgraph of  $G_1$  induced by the vertices 1,2,3,4. From part (a) we know that this subgraph determines 8 ( $= F_6$ , the sixth (nonzero) Fibonacci number) independent subsets of  $\{1,2,3,4\}$ . Therefore, the graph  $G_1$  has  $1 + F_6$  independent subsets of vertices.

Likewise the graph  $G_2$  has  $1 + F_7$  independent subsets (of vertices), and the graph  $G_n$  determines  $1 + F_{n+2}$  such subsets.

$$\begin{aligned} \text{(c) } H_1 &: 3 + F_6 = (2^2 - 1) + F_6 \\ H_2 &: 3 + F_7 = (2^2 - 1) + F_7 \\ H_3 &: 3 + F_{n+2} = (2^2 - 1) + F_{n+2} \end{aligned}$$

(d) There are  $2^s - 1 + m$  independent subsets of vertices for graph  $G' = (V', E')$ .

22. Proof: First we prove that  $G$  is connected. If not, let  $C_1, C_2$  be two of the components of  $G$  and let  $v_1, v_2 \in V$  with  $v_1$  a vertex in  $C_1$  and  $v_2$  a vertex in  $C_2$ . If  $C_1$  has  $n_1$  vertices and  $C_2$  has  $n_2$  vertices, then  $10 = \deg(v_1) + \deg(v_2) \leq (n_1 - 1) + (n_2 - 1) = (n_1 + n_2) - 2 \leq 8$ . This contradiction tells us that  $G$  is connected.

Here  $|E| = \left(\frac{1}{2}\right) \sum_v \deg(v) = \left(\frac{1}{2}\right)(50) = 25$ . If  $G$  were planar, then we would have  $25 = |E| \leq 3|V| - 6 = 3(10) - 6 = 24$ , according to Corollary 11.3. This contradiction now tells us that  $G$  is nonplanar.

CHAPTER 12  
TREES

Section 12.1

1. (a)



(b) 5

2.  $|E_1| = 17 \implies |V_2| = 18. \quad |V_2| = 2|V_1| = 36 \implies |E_2| = 35.$

3. (a) Let  $e_1, e_2, \dots, e_7$  denote the numbers of edges for the seven trees, and let  $v_1, v_2, \dots, v_7$ , respectively, denote the numbers of vertices. Then  $v_i = e_i + 1$ , for all  $1 \leq i \leq 7$ , and  $|V_1| = v_1 + v_2 + \dots + v_7 = (e_1 + e_2 + \dots + e_7) + 7 = 40 + 7 = 47.$

(b) Let  $n$  denote the number of trees in  $F_2$ . Then if  $e_i, v_i, 1 \leq i \leq n$ , denote the numbers of edges and vertices, respectively, in these trees, it follows that  $v_i = e_i + 1$ , for all  $1 \leq i \leq n$ , and  $62 = v_1 + v_2 + \dots + v_n = (e_1 + 1) + (e_2 + 1) + \dots + (e_n + 1) = (e_1 + e_2 + \dots + e_n) + n = 51 + n$ , so  $n = 62 - 51 = 11$  trees in  $F_2$ .

4.  $e = v - \kappa$

5. A path is a tree with only two pendant vertices.

6. (a) Since a tree contains no cycles it cannot have a subgraph homeomorphic to either  $K_5$  or  $K_{3,3}$ .

(b) If  $T = (V, E)$  is a tree then  $T$  is connected and, by part (a),  $T$  is planar. By Theorem 11.6,  $|V| - |E| + 1 = 2$  or  $|V| = |E| + 1.$

7.

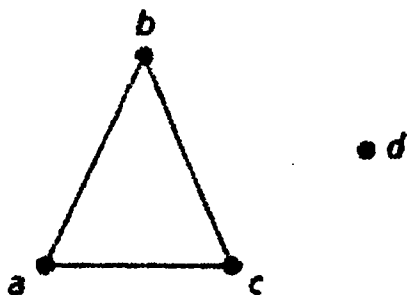

8. (a) Let  $x$  be the number of pendant vertices. Then  $2|E| = \sum_{v \in V} \deg(v) = x + 4(2) + 1(3) + 2(4) + 1(5)$  and  $|E| = |V| - 1 = x + 4 + 1 + 2 + 1 - 1 = x + 7$ .

So  $2(x + 7) = x + 24$  and  $x = 10$ .

$$(b) 2|E| = \sum_{v \in V} \deg(v) = v_1 + v_2(2) + v_3(3) + \dots + v_m(m)$$

$$|E| = |V| - 1 = (v_1 + v_2 + \dots + v_m) - 1$$

$$2(v_1 + v_2 + \dots + v_m - 1) = v_1 + 2v_2 + \dots + mv_m, \text{ so } v_1 = v_3 + 2v_4 + 3v_5 + \dots + (m-2)v_m + 2,$$

$$\text{and } |V| = v_1 + v_2 + \dots + v_m = [v_3 + 2v_4 + \dots + (m-2)v_m + 2] + v_2 + v_3 + \dots + v_m = v_2 + 2v_3 + 3v_4 + \dots + (m-1)v_m + 2, |E| = |V| - 1 = v_2 + 2v_3 + \dots + (m-1)v_m + 1.$$

9. If there is a (unique) path between each pair of vertices in  $G$  then  $G$  is connected. If  $G$  contains a cycle then there is a pair of vertices  $x, y$  with two distinct paths connecting  $x$  and  $y$ . Hence,  $G$  is a loop-free connected undirected graph with no cycles, so  $G$  is a tree.

10. 31

11. Since  $T$  is a tree, there is a unique path connecting any two distinct vertices of  $T$ . Hence there are  $\binom{n}{2}$  distinct paths in  $T$ .

12. If  $G$  contains no cycles then  $G$  is a tree. But then  $G$  must have at least two pendant vertices. This graph has only one pendant vertex.

13. (a) In part (i) of the given figure we find the complete bipartite graph  $K_{2,3}$ . Parts (ii) and (iii) of the figure provide two nonisomorphic spanning trees for  $K_{2,3}$ .

(b) Up to isomorphism these are the only spanning trees for  $K_{2,3}$ .

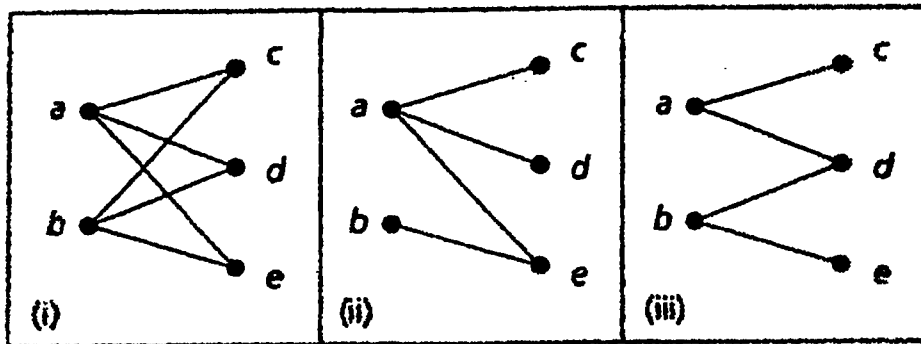

14. Let  $V = \{x, y, w_1, w_2, \dots, w_n\}$  be the vertices for  $K_{2,n}$ , where  $V_1 = \{x, y\}$ ,  $V_2 = \{w_1, w_2, \dots, w_n\}$  and all edges have one vertex in  $V_1$  and the other in  $V_2$ . If  $T$  is a spanning tree for  $K_{2,n}$ , then  $T$  has  $n + 1$  edges and  $\deg(x) + \deg(y) = n + 1$ . So the number of nonisomorphic

spanning trees for  $K_{2,n}$  is the number of partitions of  $n$  into two (nonzero) summands. This number is  $\lfloor (n+1)/2 \rfloor$ .

15. (a) 6: Any one of the six spanning trees for  $C_6$  (the cycle on six vertices) together with the path connecting  $f$  to  $k$ .  
 (b)  $6 \cdot 6 = 36$
16. (1) This graph has  $9 = 3 \cdot 4 - 3 = 3 + 3(4 - 2)$  vertices, so any spanning tree for it will have eight edges. There are  $12 = 3 \cdot 4$  edges (in total) so we shall remove four edges. Two edges must be removed from one 4-cycle (a cycle on four vertices) and one edge from each of the other two 4-cycles. When two edges from a 4-cycle are removed one must be from the 3-cycle (induced by  $a, b$ , and  $c$ ) – otherwise, we get a disconnected subgraph. There are three ways to select the 4-cycle for removing two edges and three ways to select the edge not on the 3-cycle. We then select one edge from each of the remaining 4-cycles in  $4 \cdot 4$  ways. So the number of nonidentical spanning trees for this graph is  $3(4 - 1)(4^2) = 144$ .  
 (2) Here the graph has  $8 = 4 \cdot 3 - 4 = 4 + 4(3 - 2)$  vertices and  $12 = 4 \cdot 3$  edges. There are  $4(3 - 1)(3^3) = 216$  nonidentical spanning trees.  
 (3) This graph has  $16 = 4 \cdot 5 - 4 = 4 + 4(5 - 2)$  vertices and  $20 = 4 \cdot 5$  edges. There are  $4(5 - 1)(5^3) = 2000$  nonidentical spanning trees.

17. (a)  $n \geq m + 1$   
 (b) Let  $k$  be the number of pendant vertices in  $T$ . From Theorem 11.2 and Theorem 12.3 we have

$$2(n - 1) = 2|E| = \sum_{v \in V} \deg(v) \geq k + m(n - k).$$

Consequently,  $[2(n - 1) \geq k + m(n - k)] \Rightarrow [2n - 2 \geq k + mn - mk] \Rightarrow [k(m - 1) \geq 2 - 2n + mn = 2 + (m - 2)n \geq 2 + (m - 2)(m + 1) = 2 + m^2 - m - 2 = m^2 - m = m(m - 1)]$ , so  $k \geq m$ .

18.  $\sum_{v \in V} \deg(v) = 2|E| = 2(|V| - 1) = 2(999) = 1998$ .
19. (a) If the complement of  $T$  contains a cut set, then the removal of these edges disconnects  $G$  and there are vertices  $x, y$  with no path connecting them. Hence  $T$  is not a spanning tree for  $G$ .  
 (b) If the complement of  $C$  contains a spanning tree, then every pair of vertices in  $G$  has a path connecting them and this path includes no edges of  $C$ . Hence the removal of the edges in  $C$  from  $G$  does not disconnect  $G$ , so  $C$  is not a cut set for  $G$ .
20. (d)  $\implies$  (e): Let  $C$  be a cycle (in  $G$ ) with  $r$  vertices and  $r$  edges. Since  $G$  is connected, the remaining vertices of  $G$  can each be connected to a vertex in  $C$  by a path (in  $G$ ). Each such connection requires at least one new edge. Consequently, in  $G$ ,  $|E| \geq |V|$ , contradicting  $|V| = |E| + 1$ . So  $G$  has no cycles and is connected, and  $G$  is a tree. Let  $G'$  be the graph obtained by adding edge  $\{a, b\}$  to  $G$ . Since  $\{a, b\} \notin E$ , there is a unique path  $P$ , of length at least 2 in  $G$ , that connects  $a$  to  $b$ . In

$G', P \cup \{\{a, b\}\}$  is a cycle. If  $G'$  contains a second cycle  $C_1$ , then  $C_1$  must contain edge  $\{a, b\}$ . If not, then  $G$  would contain a cycle. This second cycle  $C_1 = P_1 \cup \{\{a, b\}\}$ , where  $P_1$  is a path in  $G$  and  $P_1 \neq P$ . This contradicts Theorem 12.1.

(e)  $\implies$  (a): If  $G$  is not connected, let  $C_1, C_2$  be components of  $G$  with  $a \in C_1, b \in C_2$ . Then adding the edge  $\{a, b\}$  to  $G$  would not result in a cycle. Consequently,  $G$  is connected with no cycles, so  $G$  is a tree.

21. (a) (i) 3,4,6,3,8,4                      (ii) 3,4,6,6,8,4

(b) No pendant vertex of the given tree appears in the sequence so the result is true for these vertices. When an edge  $\{x, y\}$  is removed and  $y$  is a pendant vertex (of the tree or one of the resulting subtrees), then the  $\deg(x)$  is decreased by 1 and  $x$  is placed in the sequence. As the process continues either (i) this vertex  $x$  becomes a pendant vertex in a subtree and is removed but not recorded in the sequence, or (ii) the vertex  $x$  is left as one of the last two vertices of an edge. In either case  $x$  has been listed in the sequence  $(\deg(x) - 1)$  times.

(c)

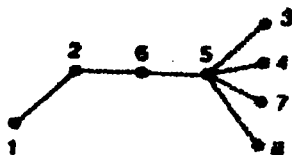

(d) Input: The given Prüfer code  $x_1, x_2, \dots, x_{n-2}$ .

Output: The unique tree  $T$  with  $n$  vertices labeled with  $1, 2, \dots, n$ . (This tree  $T$  has the Prüfer code  $x_1, x_2, \dots, x_{n-2}$ .)

```

C := [x1, x2, ..., xn-2]      {Initializes C as a list (ordered set).}
L := [1, 2, ..., n]           {Initializes L as a list (ordered set).}
T := ∅
for i := 1 to n - 2 do
    v := smallest element in L not in C
    w := first entry in C
    T := T ∪ {{v, w}}          {Add the new edge {v, w} to the present forest.}
    delete v from L
    delete the first occurrence of w from C
T := T ∪ {{y, z}}             {The vertices y, z are the last two remaining entries in L.}

```

22. Let  $V$  be the vertex set for  $K_n$ . From the previous exercise we know that there are  $(n-1)^{n-3}$  spanning trees for the subgraph of  $K_n$  induced by  $V - v$  (namely, the complete graph  $K_{n-1}$ ). For  $v$  to be a pendant vertex it can be adjacent to only one of the  $n-1$  vertices in  $V - v$ . Consequently, there are  $(n-1)[(n-1)^{n-3}]$  spanning trees of  $K_n$  where  $v$  is a pendant vertex.

23. (a) If the tree contains  $n + 1$  vertices then it is (isomorphic to) the complete bipartite graph  $K_{1,n}$  – often called the *star* graph.  
 (b) If the tree contains  $n$  vertices then it is (isomorphic to) a path on  $n$  vertices.
24. Consider the Prüfer codes for the  $n^{n-2}$  labeled trees on  $n$  vertices. For a given labeled tree, the pendant vertices (of degree 1) have the labels which do *not* appear in the Prüfer code for that tree. If there are  $k$  pendant vertices, then there are  $k$  labels missing from the code and these can be selected in  $\binom{n}{k}$  ways. That leaves  $n - k$  labels that must *all* be placed in the  $n - 2$  positions of the Prüfer code. This can be counted as the number of *onto* functions from the set of  $n - 2$  positions to the set of  $n - k$  labels – that is,  $(n - k)! S(n - 2, n - k)$ .

The result then follows by the rule of product.

25. Let  $E_1 = \{\{a, b\}, \{b, c\}, \{c, d\}, \{d, e\}, \{b, h\}, \{d, i\}, \{f, i\}, \{g, i\}\}$  and  
 $E_2 = \{\{a, h\}, \{b, i\}, \{h, i\}, \{g, h\}, \{f, g\}, \{c, i\}, \{d, f\}, \{e, f\}\}$ .

### Section 12.2

1. (a) f,h,k,p,q,s,t                      (b) a                      (c) d  
 (d) e,f,j,q,s,t                      (e) q,t                      (f) 2  
 (g) k,p,q,s,t

2. (a)

Vertex	Level Number
<i>p</i>	35
<i>s</i>	36
<i>t</i>	36
<i>v</i>	37
<i>w</i>	38
<i>x</i>	38
<i>y</i>	39
<i>z</i>	39

- (b) The vertex *u* has 37 ancestors.  
 (c) The vertex *y* has 39 ancestors.
3. (a)  $1 + w - x y + \pi \uparrow z 3$                       (b) 0.4
4. (a) 5                      (b) 2.1.3                      (c) 4 (including the root)  
 (d) 2.1.3.*x*,  $1 \leq x \leq 5$ ; 2.1.3, 2.1.2, 2.1.1, 2.1, 2, 1.

5. Preorder: r,j,h,g,e,d,b,a,c,f,i,k,m,p,s,n,q,t,v,w,u  
 Inorder: h,e,a,b,d,c,g,f,j,i,r,m,s,p,k,n,v,t,w,q,u  
 Postorder: a,b,c,d,e,f,g,h,i,j,s,p,m,v,w,t,u,q,n,k,r

6. Preorder: 1,2,5,9,14,15,10,16,17,3,6,4,7,8,11,12,13  
 Postorder: 14,15,9,16,17,10,5,2,6,3,7,11,12,13,8,4,1

7. (a)

(i) & (iii)

(ii)

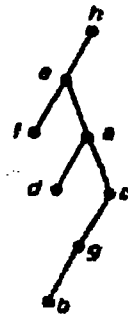

(b)

(i)

(ii)

(iii)

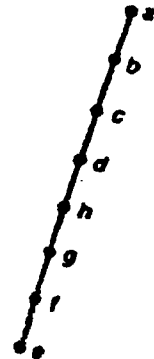
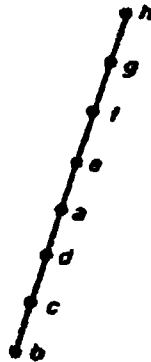
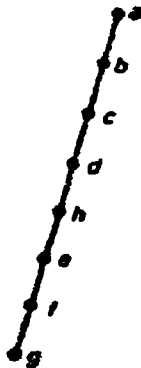

8. (a) (i) & (iii)

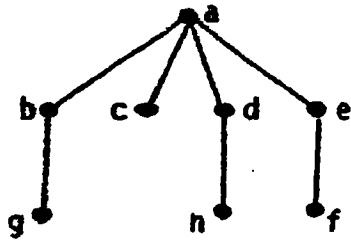

(ii)

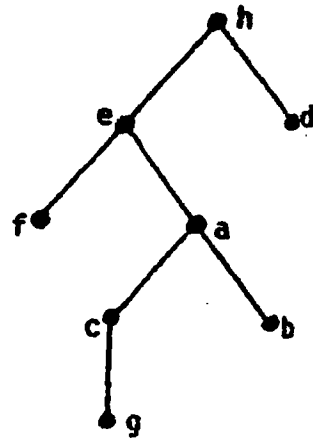

(b) (i) & (iii)

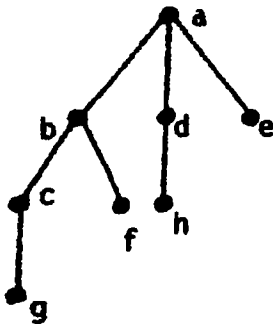

(ii)

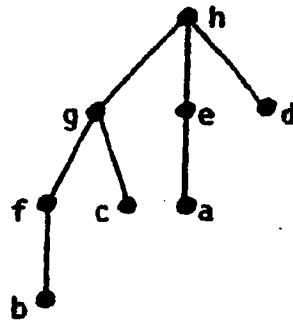

9.

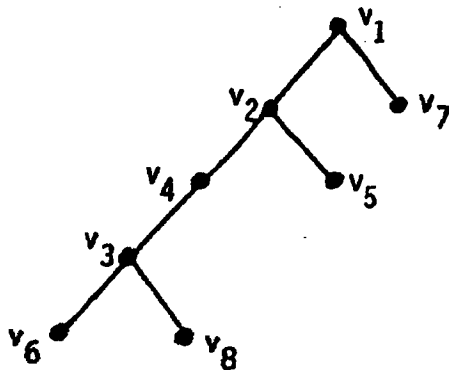

$G$  is connected.

10. (a) Here the maximum height is  $n - 1$ .

(b) In this case  $n$  must be odd and the maximum height is  $(n - 1)/2$ .

11. Theorem 12.6

(a) Each internal vertex has  $m$  children so there are  $mi$  vertices that are the children of some other vertex. This accounts for all vertices in the tree except the root. Hence  $n = mi + 1$

(b)  $\ell + i = n = mi + 1 \implies \ell = (m - 1)i + 1$

$$(c) \ell = (m-1)i + 1 \implies i = (\ell - 1)/(m-1)$$

$$n = mi + 1 \implies i = (n-1)/m.$$

(Corollary 12.1)

Since the tree is balanced  $m^{h-1} < \ell \leq m^h$  by Theorem 12.7.

$$m^{h-1} < \ell \leq m^h \implies \log_m(m^{h-1}) < \log_m(\ell) \leq \log_m(m^h) \implies$$

$$(h-1) < \log_m \ell \leq h \implies h = \lceil \log_m \ell \rceil.$$

12. From Theorem 12.6 (c) we have

$$(a) (\ell - 1)/(m - 1) = (n - 1)/m \implies (n - 1)(m - 1) = m(\ell - 1) \implies$$

$$n - 1 = (m\ell - m)/(m - 1) \implies n = \lceil (m\ell - m)/(m - 1) \rceil + 1 =$$

$$\lceil (m\ell - m) + (m - 1) \rceil / (m - 1) = (m\ell - 1)/(m - 1).$$

$$(b) (\ell - 1)/(m - 1) = (n - 1)/m \implies \ell - 1 = (m - 1)(n - 1)/m \implies$$

$$\ell = \lceil (m - 1)(n - 1) + m \rceil / m = \lceil (m - 1)n + 1 \rceil / m.$$

13. (a) From part (a) of Theorem 12.6 we have  $|V| = \text{number of vertices in } T = 3i + 1 = 3(34) + 1 = 103$ . So  $T$  has  $103 - 1 = 102$  edges. From part (b) of the same theorem we find that the number of leaves in  $T$  is  $(3 - 1)(34) + 1 = 69$ . [We can also obtain the number of leaves as  $|V| - i = 103 - 34 = 69$ .]

(b) It follows from part (c) of Theorem 12.6 that the given tree has  $(817 - 1)/(5 - 1) = 816/4 = 204$  internal vertices.

14. (a)

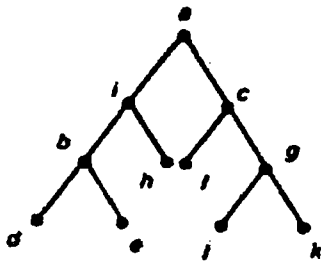

(b)

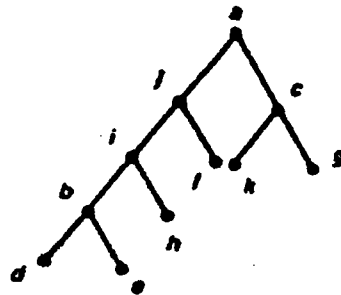

15. (a)

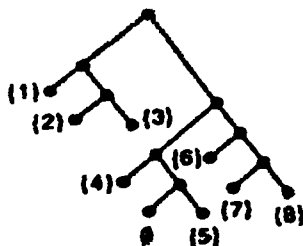

(b) 9; 5

(c)  $h(m-1)$ ;  $(h-1) + (m-1)$

16. (a) From Theorem 12.6 (c), with  $\ell = 25$ ,  $m = 2$ , it follows that  $i = (25 - 1)/(2 - 1) = 24$ . Hence 24 cans of tennis balls are opened and 24 matches are played.  
 (b) Either 4 or 5.
17. 21845;  $1 + m + m^2 + \dots + m^{h-1} = (m^h - 1)/(m - 1)$ .
18.  $2[5 + 5^2 + 5^3 + 5^4 + 5^5 + 5^6 + 5^7]$ ;  $2[5^5 + 5^6 + 5^7]$
- 19.

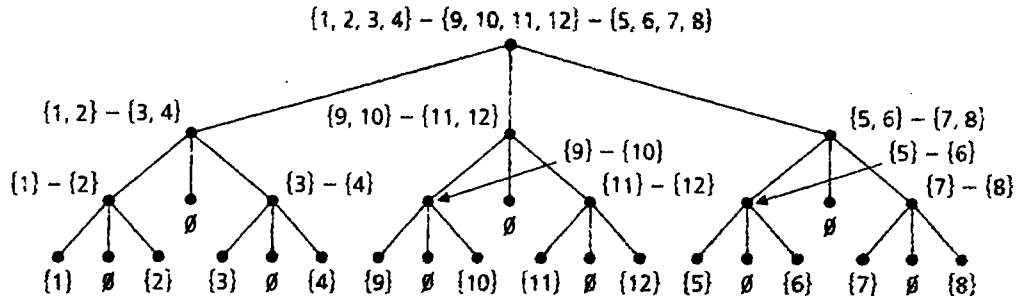

20. The number of vertices at level  $h - 1$  is  $m^{h-1}$ . Among these we find  $m^{h-1} - b_{h-1}$  of the  $l$  leaves of  $T$ . Each of the  $b_{h-1}$  branch nodes account for  $m$  leaves (at level  $h$ ). Therefore,  $l = m^{h-1} - b_{h-1} + mb_{h-1} = m^{h-1} + (m - 1)b_{h-1}$ .
21. Let  $T$  be a complete binary tree with 31 vertices. The left and right subtrees of  $T$  are then *complete binary trees* on  $2k + 1$  and  $30 - (2k + 1)$  vertices, respectively, with  $0 \leq k \leq 14$ .  
 The number of ways the left subtree can have  $11 (= 2 \cdot 5 + 1)$  vertices is  $\binom{1}{6} \binom{10}{5}$ . This leaves  $19 (= 2 \cdot 9 + 1)$  vertices for the right subtree where there are  $\binom{1}{10} \binom{18}{9}$  possibilities. So by the rule of product there are  $\binom{1}{6} \binom{10}{5} \binom{1}{10} \binom{18}{9} = 204,204$  complete binary trees on 31 vertices with 11 vertices in the left subtree of the root. A similar argument tells us that there are  $\binom{1}{11} \binom{20}{10} \binom{1}{5} \binom{8}{4} = 235,144$  complete binary trees on 31 vertices with 21 vertices in the right subtree of the root.
22.  $a_{n+1} = a_0 a_n + a_1 a_{n-1} + a_2 a_{n-2} + \dots + a_{n-1} a_1 + a_n a_0$   
 [Compare with the equation for  $b_{n+1}$  in Section 10.5.]
23. (a) 1,2,5,11,12,13,14,3,6,7,4,8,9,10,15,16,17  
 (b) The preorder traversal of the rooted tree.
24. (a) 11,12,13,14,5,2,6,7,3,8,9,15,16,17,10,4,1  
 (b) The postorder traversal of the rooted tree.

Here the algorithm is iterative, while the one given in Definition 12.3 is recursive.

Section 12.3

1. (a)  $L_1: 1, 3, 5, 7, 9$      $L_2: 2, 4, 6, 8, 10$   
 (b)  $L_1: 1, 3, 5, 7, \dots, 2m-3, m+n$   
 $L_2: 2, 4, 6, 8, \dots, 2m-2, 2m-1, 2m, 2m+1, \dots, m+n-1$

2. (a)

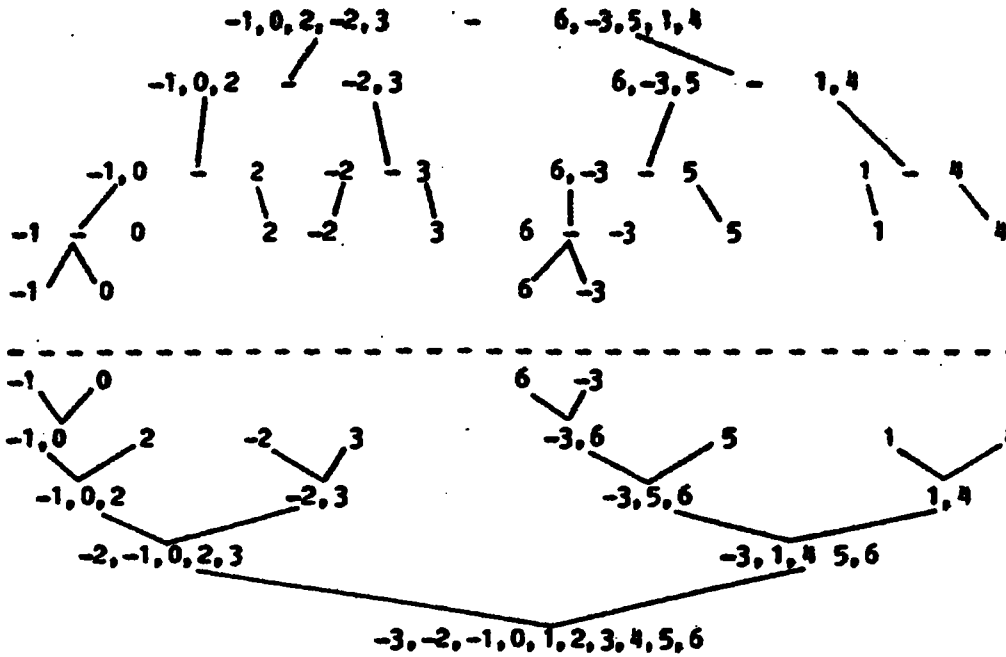

(b)

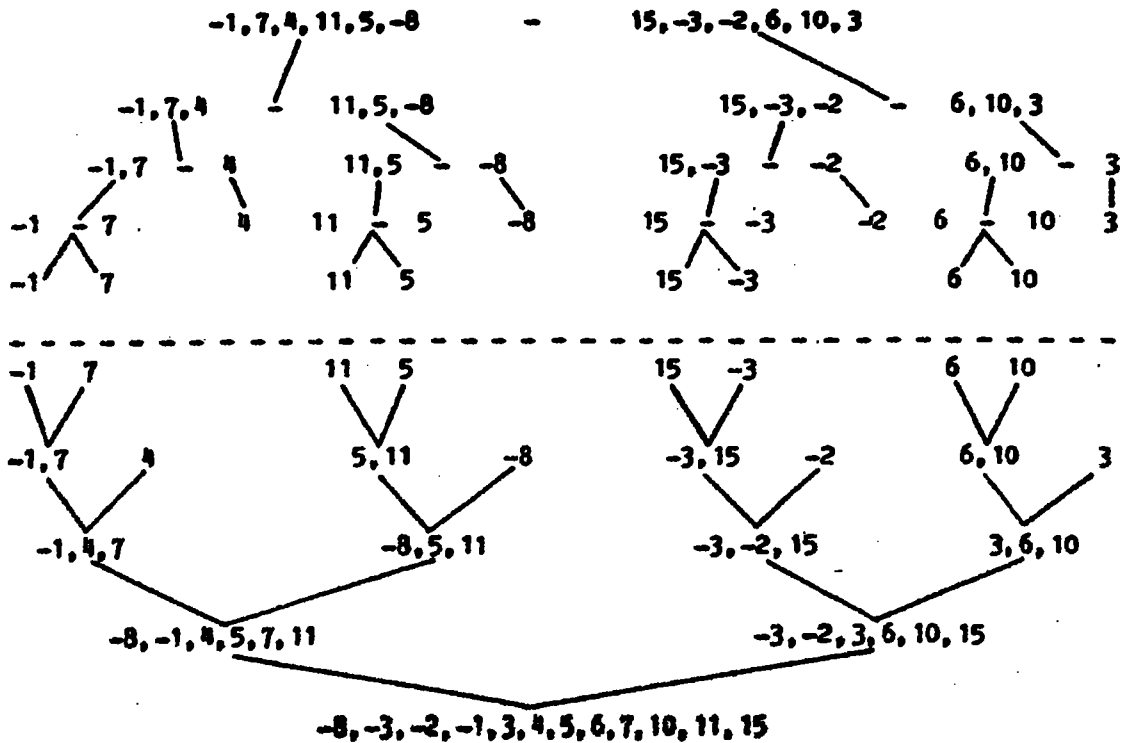

3. (a)

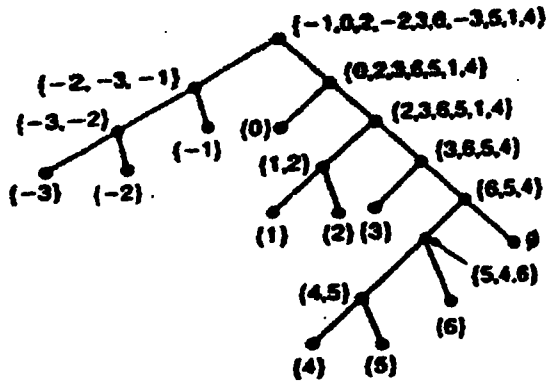

(b)

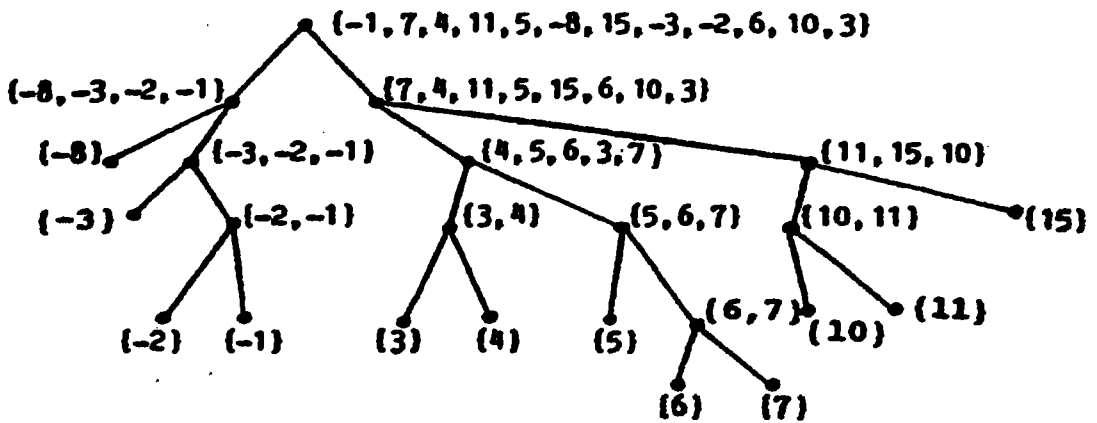

4. To establish this result we use mathematical induction (the alternative form). We know that  $g(1) \leq g(2) \leq g(3) \leq g(4)$ . So we assume that for all  $i, j \in \{1, 2, 3, \dots, n\}$ ,  $i < j \implies g(i) \leq g(j)$ . Considering the case for  $n + 1$  we have two results to examine.

(1) If  $n + 1$  is odd then  $n + 1 = 2k + 1$  for some  $k \in \mathbb{Z}^+$ . In the worst case,  $g(n + 1) = g(2k + 1) = g(k) + g(k + 1) + [k + (k + 1) - 1] = g(k) + g(k + 1) + 2k \geq g(k) + g(k) + (2k - 1) = g(2k) = g(n)$ , since  $g(k + 1) \geq g(k)$  by the induction hypothesis.

(2) If  $n + 1$  is even, then  $n + 1 = 2t$  for some  $t \in \mathbb{Z}^+$ . In the worst case,  $g(n + 1) = g(2t) = g(t) + g(t) + [t + t - 1] = g(t) + g(t) + (2t - 1) \geq g(t) + g(t - 1) + (2t - 2) = g(2t - 1) = g(n)$ , because  $g(t) \geq g(t - 1)$  by the induction hypothesis.

Consequently  $g$  is a monotone increasing function.

## Section 12.4

1. (a) tear                      (b) tatener                      (c) rant
2.  $x = y = z = 1$
3.
 

a: 111	e: 10	h: 010
b: 110101	f: 0111	i: 00
c: 0110	g: 11011	j: 110100
d: 0001		
4. (a)  $2^3$                       (b)  $2^7$                       (c)  $2^{12}$                       (d)  $2^h$
5. Since the tree has  $m^7 = 279,936$  leaves, it follows that  $m = 6$ . From part(c) of Theorem 12.6 we find that there are  $(m^7 - 1)/(m - 1) = (279,935)/5 = 55,987$  internal vertices.
6.  $v = 1 + m + m^2 + \dots + m^h = (1 - m^{h+1})/(1 - m) = (m^{h+1} - 1)/(m - 1)$ , so  $v(m - 1) + 1 = m^{h+1}$ . Consequently,  $h + 1 = \log_m[v(m - 1) + 1]$  and  $h = \log_m[v(m - 1) + 1] - 1$ .

7.

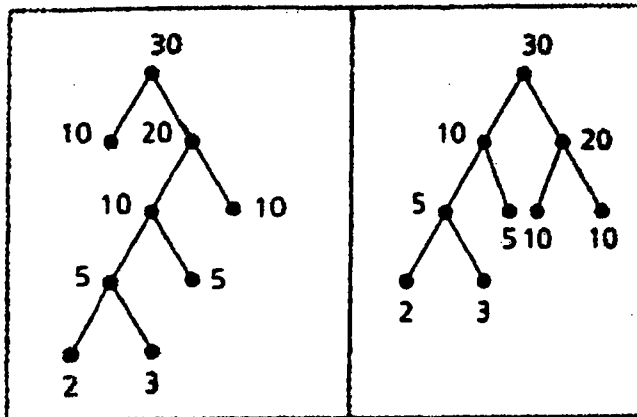

Amend part (a) of Step 2 for the Huffman tree algorithm as follows. If there are  $n(> 2)$  such trees with smallest root weights  $w$  and  $w'$ , then

- (i) if  $w < w'$  and  $n - 1$  of these trees have root weight  $w'$ , select a tree (of root weight  $w'$ ) with smallest height; and
- (ii) if  $w = w'$  (and all  $n$  trees have the same smallest root weight), select two trees (of root weight  $w$ ) of smallest height.

8. (a) To merge lists  $L_1$  and  $L_2$  requires at most  $75 + 40 - 1 = 114$  comparisons (from Lemma 12.1), for  $L_3$  and  $L_4$  at most  $110 + 50 - 1 = 159$  comparisons. Merging the two resulting lists then requires at most  $115 + 160 - 1 = 274$  comparisons for a total of at most  $114 + 159 + 274 = 547$  comparisons.

(b) At most 114; at most 224 (338 at most, in total); at most 274 (in total, at most 612).

(c) Merge  $L_2$  and  $L_4$ , then merge the resulting list (for  $L_2, L_4$ ) with  $L_1$ , and finally merge the resulting list (for  $L_1, L_2, L_4$ ) with  $L_3$ . This requires at most a total of  $89 + 164 + 274 = 527$  comparisons.

(d) In order to minimize the number of comparisons in the sorting process construct an optimal tree with the weights  $w_i$ ,  $1 \leq i \leq n$ , given by  $w_i = |L_i|$ .

## Section 12.5

- The articulation points are  $b, e, f, h, j, k$ . The biconnected components are

$B_1 : \{\{a, b\}\}; B_2 : \{\{d, e\}\};$   
 $B_3 : \{\{b, c\}, \{c, f\}, \{f, e\}, \{e, b\}\}; B_4 : \{\{f, g\}, \{g, h\}, \{h, f\}\};$   
 $B_5 : \{\{h, i\}, \{i, j\}, \{j, h\}\}; B_6 : \{\{j, k\}\};$   
 $B_7 : \{\{k, p\}, \{p, n\}, \{n, m\}, \{m, k\}, \{p, m\}\}.$
- If every path from  $x$  to  $y$  contains the vertex  $z$ , then splitting the vertex  $z$  will result in at least two components  $C_x, C_y$  where  $x \in C_x, y \in C_y$ . If not, there is a path that still connects  $x$  and  $y$  and this path does not include vertex  $z$ . Conversely, if  $z$  is an articulation point of  $G$  then the splitting of  $z$  results in at least two components  $C_1, C_2$  for  $G$ . Select  $x \in C_1, y \in C_2$ . Since  $G$  is connected there is at least one path from  $x$  to  $y$ , but since  $x$  and  $y$  become separated upon the splitting of  $z$ , every path connecting  $x$  and  $y$  in  $G$  contains the vertex  $z$ .
- (a)  $T$  can have as few as one or as many as  $n - 2$  articulation points. If  $T$  contains a vertex of degree  $(n - 1)$ , then this vertex is the only articulation point. If  $T$  is a path with  $n$  vertices and  $n - 1$  edges, then the  $n - 2$  vertices of degree 2 are all articulation points.

(b) In all cases, a tree on  $n$  vertices has  $n - 1$  biconnected components. Each edge is a biconnected component.
- (a) From Exercise 2, if  $v$  is an articulation point in  $T$  then there are vertices  $x, y$  where every path from  $x$  to  $y$  includes vertex  $v$ . Hence  $\deg(v) > 1$ . Conversely, if  $\deg(v) > 1$ , let  $a, b \in V$  such that  $\{a, v\}, \{v, b\} \in E$ . Then in splitting vertex  $v$ , the tree is separated into components  $C_a, C_b$  containing  $a, b$ , respectively. If not, there is another path from  $a$  to  $b$  that does not include  $v$ . This contradicts Theorem 12.1.

(b) Since  $G$  is connected,  $G$  has a spanning tree  $T = (V, E')$ . This tree has at least two pendant vertices. Let  $v$  be a pendant vertex in  $T$ . If  $v$  is an articulation point of  $G$ , then there are vertices  $x, y$  in  $G$  such that every path connecting  $x$  and  $y$  contains  $v$ . But then one of these paths must be in  $T$ . So  $\deg_T(v) > 1$ , contradicting  $v$  being a pendant vertex.
- $\chi(G) = \max\{\chi(B_i) | 1 \leq i \leq k\}.$

6. The graph  $G$  has  $n_1 \cdot n_2 \cdots n_8$  distinct spanning trees.
7. **Proof:** Suppose that  $G$  has a pendant vertex, say  $x$ , and that  $\{w, x\}$  is the (unique) edge in  $E$  incident with  $x$ . Since  $|V| \geq 3$  we know that  $\deg(w) \geq 2$  and that  $\kappa(G - w) \geq 2 > 1 = \kappa(G)$ . Consequently,  $w$  is an articulation point of  $G$ .

8.

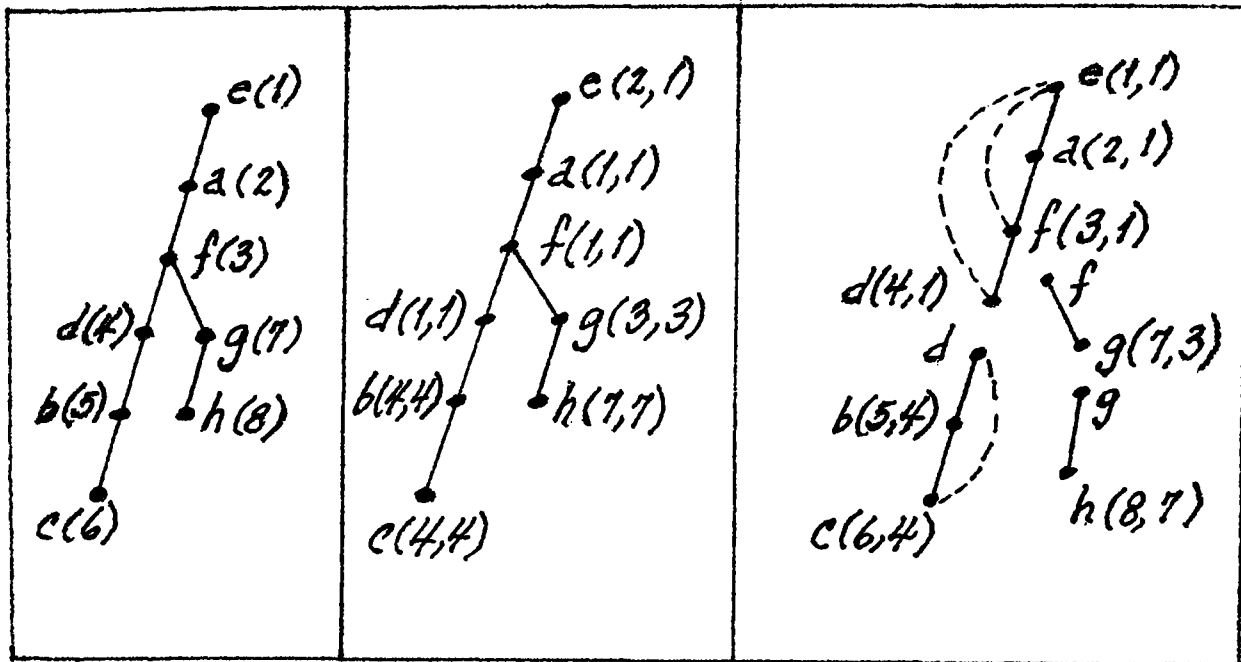

- (a) The first tree provides the depth-first spanning tree  $T$  for  $G$  with  $e$  as the root.
- (b) The second tree provides  $(\text{low}'(v), \text{low}(v))$  for each vertex  $v$  of  $G$  (and  $T$ ). These results follow from step (2) of the algorithm.

For the third tree we find  $(\text{dfi}(v), \text{low}(v))$  for each vertex  $v$ . Applying step (3) of the algorithm we find the articulation points  $d$ ,  $f$ , and  $g$ , and the four biconnected components.

9.

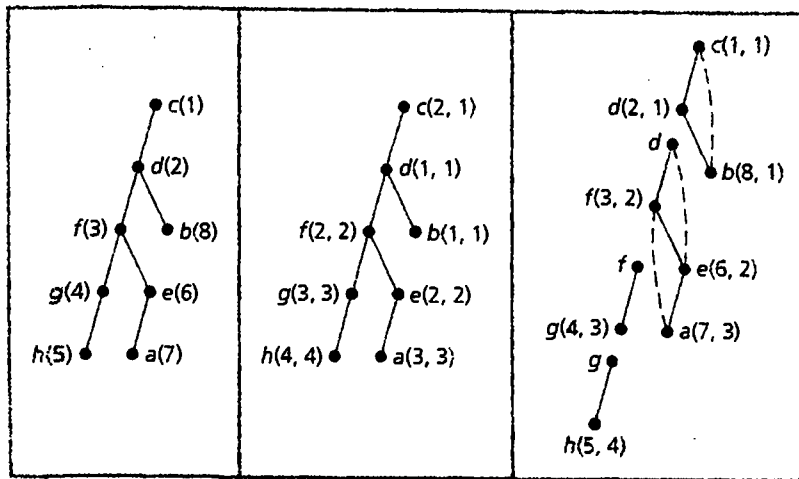

(a) The first tree provides the depth-first spanning tree  $T$  for  $G$  where the order prescribed for the vertices is reverse alphabetical and the root is  $c$ .

(b) The second tree provides  $(\text{low}'(v), \text{low}(v))$  for each vertex  $v$  of  $G$  (and  $T$ ). These results follow from step (2) of the algorithm.

For the third tree we find  $(\text{dfi}(v), \text{low}(v))$  for each vertex  $v$ . Applying step (3) of the algorithm we find the articulation points  $d, f$ , and  $g$ , and the four biconnected components.

10. The ordered pair next to each vertex  $v$  in the figure provides  $(\text{dfi}(v), \text{low}(v))$ . Following step (3) of the algorithm for determining the articulation points of  $G$  we see here that this graph has four articulation points – namely,  $c, e, f$ , and  $h$ . There are five biconnected components – the figure shows the spanning trees for these components.

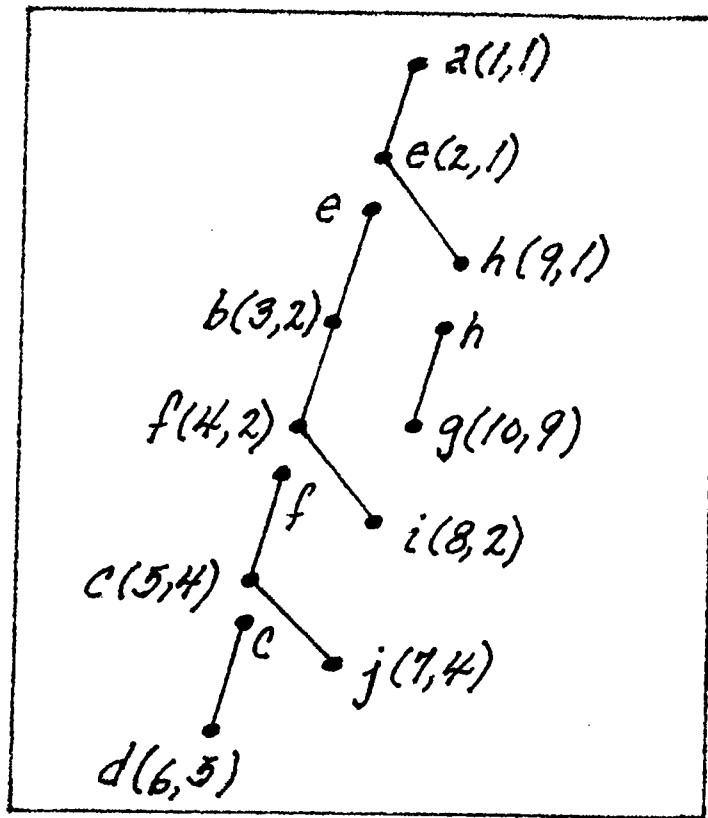

11. No! For any loop-free connected undirected graph  $G = (V, E)$  where  $|V| \geq 2$ , we have  $\text{low}(x_1) = \text{low}(x_2) = 1$ . (Note: Vertices  $x_1$  and  $x_2$  are always on the same biconnected component.)
12. (a) The vertex set for each graph is  $V - \{v\}$ . If  $e = \{x, y\}$  is an edge in  $\overline{G - v}$  then  $e$  is not in  $G - v$ , and since  $x, y \neq v$ ,  $e$  is an edge in  $\overline{G - v}$ . For the opposite inclusion if  $e = \{x, y\}$  is an edge in  $\overline{G - v}$ , then  $x, y \neq v$  and  $e$  is not an edge in  $G$ , nor the subgraph  $G - v$ . Here  $e$  is an edge in  $\overline{G - v}$ .  
 Since  $\overline{G - v}$  and  $\overline{G - v}$  have the same vertex and edge sets, these graphs are equal.
- (b) If  $v$  is an articulation point of  $G$ , then  $\kappa(G - v) > \kappa(G)$ , so  $G - v$  is not connected. But then  $\overline{G - v}$  is connected. So  $\kappa(\overline{G - v}) = \kappa(\overline{G - v}) = 1 \leq \kappa(\overline{G})$ , and consequently  $v$  cannot be an articulation point of  $\overline{G}$ .
13. Proof: If not, let  $v \in V$  where  $v$  is an articulation point of  $G$ . Then  $\kappa(G - v) > \kappa(G) = 1$ . (From Exercise 19 of Section 11.6 we know that  $G$  is connected.) Now  $G - v$  is disconnected with components  $H_1, H_2, \dots, H_t$ , for  $t \geq 2$ . For  $1 \leq i \leq t$ , let  $v_i \in H_i$ . Then  $H_i + v$  is a subgraph of  $G - v_{i+1}$ , and  $\chi(H_i + v) \leq \chi(G - v_{i+1}) < \chi(G)$ . (Here  $v_{i+1} = v_1$ .) Now let  $\chi(G) = n$  and let  $\{c_1, c_2, \dots, c_n\}$  be a set of  $n$  colors. For each subgraph  $H_i + v$ ,  $1 \leq i \leq t$ , we can properly color the vertices of  $H_i + v$  with at most  $n - 1$  colors — and can use  $c_1$  to color vertex  $v$  for all of these  $t$  subgraphs. Then we can join these  $t$  subgraphs together at vertex  $v$  and obtain a proper coloring for the vertices of  $G$  where we use less than  $n (= \chi(G))$  colors.

14. No! Consider the graph and breadth-first spanning tree shown in the figure. Here  $\{c, d\} \in E$  and  $\{c, d\} \notin E'$ , but  $c$  is neither an ancestor nor a descendant of  $d$  in the tree  $T$ .

### Supplementary Exercises

1. If  $G$  is a tree, consider  $G$  as a rooted tree. Then there are  $\lambda$  choices for coloring the root of  $G$  and  $(\lambda - 1)$  choices for coloring each of its descendants. The result then follows by the rule of product.

Conversely, if  $P(G, \lambda) = \lambda(\lambda - 1)^{n-1}$ , then since the factor  $\lambda$  only occurs once, the graph  $G$  is connected.  $P(G, \lambda) = \lambda(\lambda - 1)^{n-1} = \lambda^n - (n - 1)\lambda^{n-1} + \dots + (-1)^{n-1}\lambda \implies G$  has  $n$  vertices and  $(n - 1)$  edges. Therefore by part (d) of Theorem 12.5,  $G$  is a tree.

2. Model the problem with a complete quaternary tree rooted at the president.
- (a) Since there are 125 executives (vertices) there are 124 edges (phone calls).
- (b) The total number of executives making calls is the number of internal vertices. From Theorem 12.6 (c),  $i = (125 - 1)/4 = 61$ . So 60 executives, in addition to the president, make calls.

3. (a) 1011001010100

(b) (i)

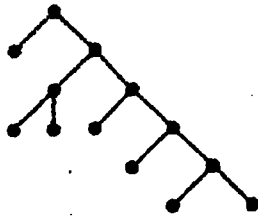

(ii)

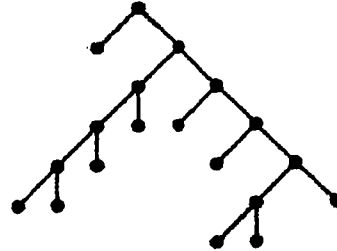

(c) Since the last two vertices visited in a preorder traversal are leaves, the last two symbols in the characteristic sequence of every complete binary tree are 00.

4. (a)  $\{1,11\} \{3,23\} \{4,9\} \{6,15\} \{-5,18\} \{2,7\} \{-10,35\} \{-2,5\}$   
 $\{-5,1,11,18\} \{2,3,7,23\} \{-10,4,9,35\} \{-2,5,6,15\}$   
 $\{-10,-5,1,4,9,11,18,35\} \{-2,2,3,5,6,7,15,23\}$   
 $\{-10,-5,-2,1,2,3,4,5,6,7,9,11,15,18,23,35\}$

(b)  $\sum_{i=1}^k (2^i - 1)2^{k-i}$

5. We assume that  $G = (V, E)$  is connected – otherwise we work with a component of  $G$ . Since  $G$  is connected, and  $\deg(v) \geq 2$  for all  $v \in V$ , it follows from Theorem 12.4 that  $G$  is not a tree. But every connected graph that is not a tree must contain a cycle.
6. From the first part of the definition of  $\mathcal{R}$  the relation is reflexive. To establish the antisym-

metric property let  $x\mathcal{R}y$  and  $y\mathcal{R}x$  for  $x, y \in V$ .  $x\mathcal{R}y \implies x$  is on the path from  $r$  to  $y$ . If  $x \neq y$  then  $x$  is encountered before  $y$  as we traverse the (unique) path from  $r$  to  $y$ . Hence by the uniqueness of such a path we cannot have  $y\mathcal{R}x$ . Hence  $(x\mathcal{R}y \wedge y\mathcal{R}x) \implies x = y$ . Lastly, let  $x, y, z \in V$  with  $x\mathcal{R}y$  and  $y\mathcal{R}z$ . Then  $x$  is on the unique path from  $r$  to  $y$  and  $y$  is on the unique path from  $r$  to  $z$ . Since these paths are unique the path from  $r$  to  $z$  must include  $x$  so  $x\mathcal{R}z$  and  $\mathcal{R}$  is transitive.

7. For  $1 \leq i (< n)$ , let  $x_i =$  the number of vertices  $v$  where  $\deg(v) = i$ . Then  $x_1 + x_2 + \dots + x_{n-1} = |V| = |E| + 1$ , so  $2|E| = 2(-1 + x_1 + x_2 + \dots + x_{n-1})$ . But  $2|E| = \sum_{v \in V} \deg(v) = (x_1 + 2x_2 + 3x_3 + \dots + (n-1)x_{n-1})$ . Solving  $2(-1 + x_1 + x_2 + \dots + x_{n-1}) = x_1 + 2x_2 + \dots + (n-1)x_{n-1}$  for  $x_1$ , we find that  $x_1 = 2 + x_3 + 2x_4 + 3x_5 + \dots + (n-3)x_{n-1} = 2 + \sum_{\deg(v_i) \geq 3} [\deg(v_i) - 2]$ .

8. (a) For all  $e \in E$ ,  $e = e$ , so  $e\mathcal{R}e$  and  $\mathcal{R}$  is reflexive.  
If  $e_1, e_2 \in E$  with  $e_1 \neq e_2$  and  $e_1\mathcal{R}e_2$ , then  $e_1$  and  $e_2$  are edges of a cycle  $C$  of  $G$ . Hence  $e_2$  and  $e_1$  are edges of the cycle  $C$ , so  $e_2\mathcal{R}e_1$  and  $\mathcal{R}$  is symmetric.

Let  $e_1, e_2, e_3$  be three distinct edges with  $e_1\mathcal{R}e_2$  and  $e_2\mathcal{R}e_3$ . Let  $C_1$  be a cycle of  $G$  containing  $e_1, e_2$  and let  $C_2$  be a cycle of  $G$  containing  $e_2, e_3$ . If  $C_1 \neq C_2$ , let  $C$  be the cycle of  $G$  made up from the edges of  $C_1, C_2$ , where common edges are removed. (In terms of edges,  $C = C_1 \Delta C_2$ .) Since  $e_1, e_3$  are on  $C$  we have  $e_1\mathcal{R}e_3$ , and  $\mathcal{R}$  is transitive.

(b) The partition of  $E$  induced by  $\mathcal{R}$  provides the biconnected components of  $G$ .

9. (a)  $G^2$  is isomorphic to  $K_5$ .  
(b)  $G^2$  is isomorphic to  $K_4$ .  
(c)  $G^2$  is isomorphic to  $K_{n+1}$ , so the number of new edges is  $\binom{n+1}{2} - n = \binom{n}{2}$ .

(d) If  $G^2$  has an articulation point  $x$ , then there exists  $u, v \in V$  such that every path (in  $G^2$ ) from  $u$  to  $v$  passes through  $x$ . (This follows from Exercise 2 of Section 12.5.) Since  $G$  is connected, there exists a path  $P$  (in  $G$ ) from  $u$  to  $v$ . If  $x$  is not on this path (which is also a path in  $G^2$ ), then we contradict  $x$  being an articulation point in  $G^2$ . Hence the path  $P$  (in  $G$ ) passes through  $x$ , and we can write  $P: u \rightarrow u_1 \rightarrow \dots \rightarrow u_{n-1} \rightarrow u_n \rightarrow x \rightarrow v_m \rightarrow v_{m-1} \rightarrow \dots \rightarrow v_1 \rightarrow v$ . But then in  $G^2$  we add the edge  $\{u_n, v_m\}$ , and the path  $P'$  (in  $G^2$ ) given by  $P': u \rightarrow u_1 \rightarrow \dots \rightarrow u_{n-1} \rightarrow u_n \rightarrow v_m \rightarrow v_{m-1} \rightarrow \dots \rightarrow v_1 \rightarrow v$  does not pass through  $x$ . So  $x$  is not an articulation point of  $G^2$ , and  $G^2$  has no articulation points.

10. (a) For the minimum value of  $|V|$  we have six leaves at level 8 and the other  $6^7 - 1$  leaves are at level 7. Since there are  $6^7 + 5$  leaves, it follows from part (c) of Theorem 12.6 that  $|V| = (6/5)[(6^7 + 5) - 1] + 1 = 335,929$ .

For the maximum value of  $|V|$  we have one leaf at level 7 and the other  $(6^7 - 1)(6)$  leaves are at level 8. So there are  $(6^8 - 6) + 1 = 6^8 - 5$  leaves in total. Once again we use part (c) of Theorem 12.6 to find that  $|V| = (6/5)[(6^8 - 5) - 1] + 1 = 2,015,533$ .

(b) Let  $\ell$  denote the number of leaves in  $T$ . For the minimum case  $\ell = (m^{h-1} - 1) + m =$

$m^{h-1} + (m - 1)$  and  $|V| = \lfloor m/(m - 1) \rfloor [m^{h-1} + (m - 1) - 1] + 1$ . For the maximum case we have  $\ell = m(m^{h-1} - 1) + 1 = m^h - m + 1$  and  $|V| = \lfloor m/(m - 1) \rfloor [m^h - m] + 1$ .

11. (a)  $\ell_n = \ell_{n-1} + \ell_{n-2}$ , for  $n \geq 3$  and  $\ell_1 = \ell_2 = 1$ . Since this is precisely the Fibonacci recurrence relation, we have  $\ell_n = F_n$ , the  $n$ th Fibonacci number, for  $n \geq 1$ .

(b)  $i_n = i_{n-1} + i_{n-2} + 1$ ,  $n \geq 3$ ,  $i_1 = i_2 = 0$ . The summand "+1" arises when we count the root, an internal vertex.

(Homogeneous part of solution):

$$i_n^{(h)} = i_{n-1}^{(h)} + i_{n-2}^{(h)}, \quad n \geq 3$$

$$i_n^{(h)} = A\alpha^n + B\beta^n, \quad \text{where } \alpha = (1 + \sqrt{5})/2 \text{ and } \beta = (1 - \sqrt{5})/2.$$

(Particular part of solution):

$$i_n^{(p)} = C, \text{ a constant}$$

Upon substitution into the recurrence relation  $i_n = i_{n-1} + i_{n-2} + 1$ ,  $n \geq 3$ , we find that

$$C = C + C + 1,$$

so  $C = -1$ ,

and  $i_n = A\alpha^n + B\beta^n - 1$ .

With  $i_1 = i_2 = 0$  we have

$$0 = i_1 = A\alpha + B\beta - 1$$

$$0 = i_2 = A\alpha^2 + B\beta^2 - 1,$$

and consequently,

$$B = (\alpha - 1)/[\beta(\alpha - \beta)] = [((1 + \sqrt{5})/2) - 1]/[((1 - \sqrt{5})/2)(\sqrt{5})] = [1 + \sqrt{5} - 2]/[(1 - \sqrt{5})(\sqrt{5})] = -1/\sqrt{5}, \text{ and } A = [1 - B\beta]/\alpha = 1/\sqrt{5}. \text{ Therefore,}$$

$$i_n = (1/\sqrt{5})\alpha^n - (1/\sqrt{5})\beta^n - 1 = F_n - 1,$$

where  $F_n$  denotes the  $n$ th Fibonacci number, for  $n \geq 1$ .

(c)  $v_n = \ell_n + i_n$ , for all  $n \in \mathbf{Z}^+$ . Consequently,  $v_n = F_n + F_n - 1 = 2F_n - 1$ , where, as in parts (a) and (b),  $F_n$  denotes the  $n$ th Fibonacci number.

12. (a) For the graph  $G_3$  in Fig. 12.48 (d) there are 12 nonidentical spanning trees in total.

(b) Consider the graph  $G_{n+1}$ . Here the nonidentical spanning trees arise from the following three cases any two of which are mutually exclusive.

(1) The edge  $\{a, n + 1\}$  is used: Here we can then use any of the  $t_n$  nonidentical spanning trees for  $G_n$ , and the result is a spanning tree for  $G_{n+1}$ .

(2) The edge  $\{n + 1, b\}$  is used: Here we have a situation similar to that in (1) and we get  $t_n$  additional nonidentical spanning trees for  $G_{n+1}$ .

(3) The edges  $\{a, n + 1\}$ ,  $\{n + 1, b\}$  are both used: Now for each vertex  $i$ , where  $1 \leq i \leq n$ , we have two choices — include the edge  $\{a, i\}$  or the edge  $\{i, b\}$  (but not both). In this way we obtain the final  $2^n$  nonidentical spanning trees for  $G_{n+1}$ .

The results in (1), (2), and (3) lead us to the following recurrence relation:

$$(*) \quad t_{n+1} = 2t_n + 2^n, \quad t_1 = 1, \quad n \geq 1.$$

(Homogeneous Solution):  $t_{n+1} = 2t_n$

$$t_n^{(h)} = A(2^n), A \text{ a constant.}$$

(Particular Solution):  $t_n^{(p)} = Bn(2^n), B \text{ a constant.}$

Substituting  $t_n^{(p)}$  into equation (\*) we find that

$$B(n+1)(2^{n+1}) = 2Bn(2^n) + 2^n$$

$$Bn(2^{n+1}) + B(2^{n+1}) = Bn(2^{n+1}) + 2^n$$

Consequently,  $2B(2^n) = 2^n$  and  $2B = 1$ , or  $B = 1/2$ . Therefore,  $t_n = A(2^n) + (1/2)n(2^n) = A(2^n) + n2^{n-1}$ .

Since  $t_1 = 1 = A(2) + 1$ ,  $A = 0$  and  $t_n = n2^{n-1}, n \geq 1$ .

13. (a) For the spanning trees of  $G$  there are two mutually exclusive and exhaustive cases:
- (i) The edge  $\{x_1, y_1\}$  is in the spanning tree: These spanning trees are counted in  $b_n$ .
  - (ii) The edge  $\{x_1, y_1\}$  is not in the spanning tree: In this case the edges  $\{x_1, x_2\}, \{y_1, y_2\}$  are both in the spanning tree. Upon removing the edges  $\{x_1, x_2\}, \{y_1, y_2\}$ , and  $\{x_1, y_1\}$ , from the original ladder graph, we now need a spanning tree for the resulting smaller ladder graph with  $n - 1$  rungs. There are  $a_{n-1}$  spanning trees in this case.
- (b) Here there are three mutually exclusive and exhaustive cases:
- (i) The edges  $\{x_1, x_2\}$  and  $\{y_1, y_2\}$  are both in the spanning tree: Delete  $\{x_1, x_2\}, \{y_1, y_2\}$ , and  $\{x_1, y_1\}$  from the graph. Then  $b_{n-1}$  counts those spanning trees for ladders with  $n - 1$  rungs where  $\{x_2, y_2\}$  is included. For each of these delete  $\{x_2, y_2\}$  and add  $\{x_1, x_2\}, \{y_1, y_2\}$  and  $\{x_1, y_1\}$ .
  - (ii) The edge  $\{x_1, x_2\}$  is in the spanning tree but the edge  $\{y_1, y_2\}$  is not: Now the removal of the edges  $\{x_1, y_1\}, \{x_1, x_2\}$ , and  $\{y_1, y_2\}$  from  $G$  results in a subgraph that is a ladder graph on  $n - 1$  rungs. This subgraph has  $a_{n-1}$  spanning trees.
  - (iii) Here the edge  $\{y_1, y_2\}$  is in the spanning tree but the edge  $\{x_1, x_2\}$  is not: As in case (ii) there are  $a_{n-1}$  spanning trees.

On the basis of the preceding argument we have  $b_n = b_{n-1} + 2a_{n-1}, n \geq 2$ .

$$(c) \quad a_n = a_{n-1} + b_n$$

$$b_n = b_{n-1} + 2a_{n-1}$$

$$a_n = a_{n-1} + b_{n-1} + 2a_{n-1} = 3a_{n-1} + b_{n-1}$$

$$b_n = a_n - a_{n-1}, \text{ so } b_{n-1} = a_{n-1} - a_{n-2}$$

$$a_n = 3a_{n-1} + a_{n-1} - a_{n-2} = 4a_{n-1} - a_{n-2}, n \geq 3, a_1 = 1, a_2 = 4$$

$$a_n - 4a_{n-1} + a_{n-2} = 0$$

$$r^2 - 4r + 1 = 0$$

$$r = (1/2)(4 \pm \sqrt{16 - 4}) = 2 \pm \sqrt{3}$$

$$\text{So } a_n = A(2 + \sqrt{3})^n + B(2 - \sqrt{3})^n$$

$$a_0 = 0 \implies A + B = 0 \implies B = -A.$$

$a_1 = 1 = A(2 + \sqrt{3}) - A(2 - \sqrt{3}) = 2A\sqrt{3} \implies A = 1/2\sqrt{3}$  and  $B = -1/2\sqrt{3}$ .  
 Therefore  $a_n = (1/(2\sqrt{3}))[(2 + \sqrt{3})^n - (2 - \sqrt{3})^n], n \geq 0$ .

14. (a)

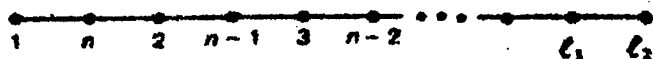

For  $n$  even,  $l_1 = n/2$  and  $l_2 = l_1 + 1$

For  $n$  odd,  $l_1 = l_2 + 1$  and  $l_2 = \lceil n/2 \rceil$

(b) Label the vertex of degree 1 with the label 1. Label the other  $n$  vertices (one vertex per label) with the labels  $2, 3, \dots, n, n + 1$ .

(c) For  $|V| = 4$  the only trees are a path of length 3 and  $K_{1,3}$ . These are handled by parts (a) and (b), respectively.

For  $|V| = 5$  there are three trees: (1) A path of length 4; (2)  $K_{1,4}$ ; and (3) The tree with a vertex of degree 3. Trees (1) and (2) are handled by parts (a) and (b), respectively. The third tree may be labeled as follows.

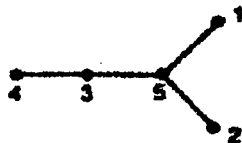

For  $|V| = 6$ , there are six trees. The path of length 5 and  $K_{1,5}$  are dealt with by parts (a) and (b), respectively. The other four trees may be labeled as follows.

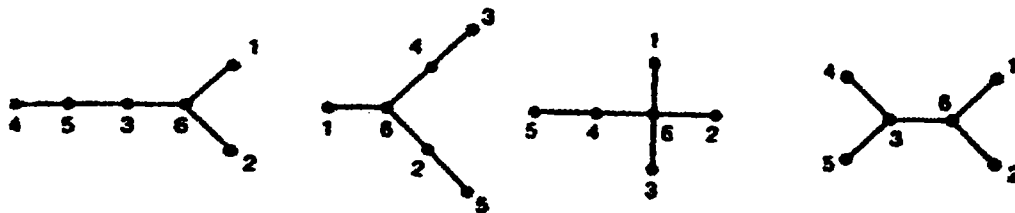



```

         $\ell := \ell + \deg(v_i) - 1$ 
    end
else
begin
    if  $v_i$  has unlabeled leaves that are not on the spine then
        assign the  $\deg(v_i) - 2$  labels from  $h - [\deg(v_i) - 3]$ 
        to  $h$  to these leaves of  $v_i$ 
        assign the label  $h - \deg(v_i) + 2$  to  $v_{i+1}$ 
         $h := h - \deg(v_i) + 1$ 
    end
end

```

18. (a) Fig. 12.50                      10001000010001  
       Fig. 12.51                      100001000010000100001  
 (b) Yes, when the caterpillar is a path.  
 (c) Yes, when the caterpillar is the complete bipartite graph (or, star)  $K_{1,n-1}$ , where  $n \geq 3$ .  
 (d)

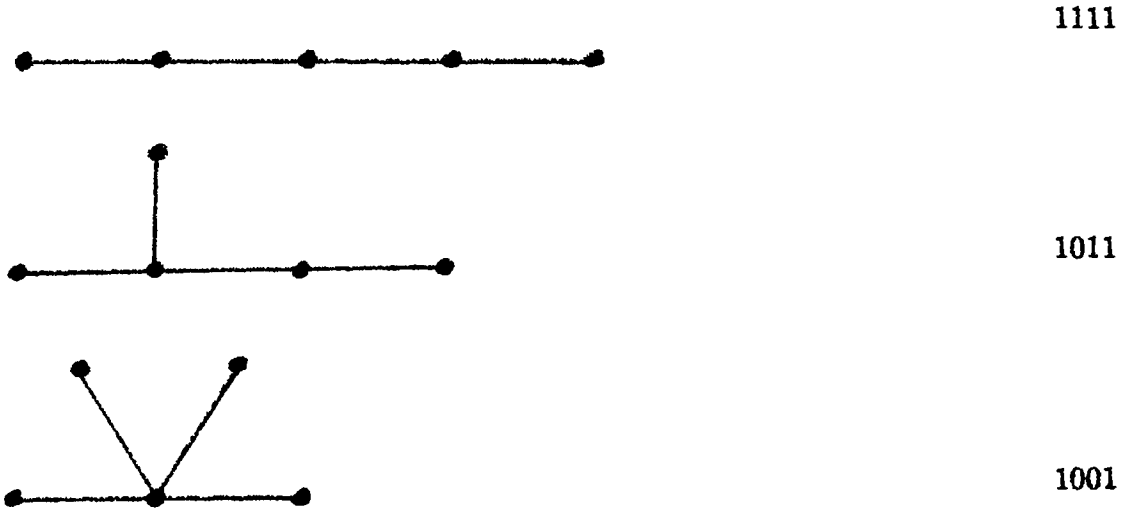

There are three nonisomorphic caterpillars on five vertices. Two of the corresponding binary strings are palindromes.

(e)

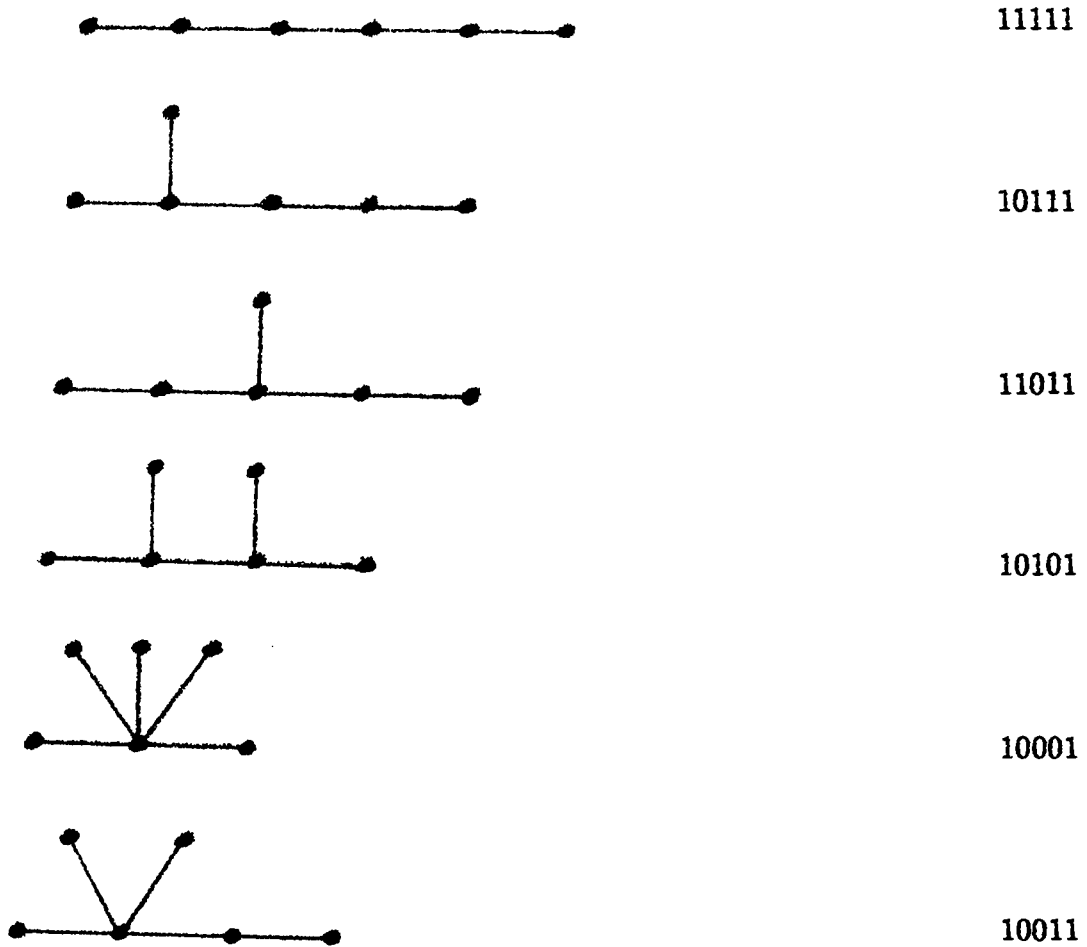

There are six nonisomorphic caterpillars on six vertices. Four of the corresponding binary strings are palindromes.

(f) Since the caterpillar has  $n$  vertices it has  $n - 1$  edges, and its binary string has  $n - 1$  bits, where the first and last bits are 1s. For each of the remaining  $n - 3$  bits there are two choices - 0 or 1. This gives us  $2^{n-3}$  binary strings. However, for each binary string  $s$  that is not a palindrome, the reversal of that string - namely,  $s^R$  - corresponds with a caterpillar that is isomorphic to the caterpillar determined by  $s$ . So each pair of these strings -  $s$  and  $s^R$  - determines only one (nonisomorphic) caterpillar. Further, each palindrome also determines a unique caterpillar. For the palindromes we have two choices for each of the first  $\lfloor (n - 3)/2 \rfloor$  positions (after the first 1). So there are  $2^{\lfloor (n-3)/2 \rfloor}$  binary strings that are palindromes. Consequently,  $2^{n-3} + 2^{\lfloor (n-3)/2 \rfloor}$  counts each of the nonisomorphic caterpillars on  $n$  vertices twice. Therefore, the number of nonisomorphic caterpillars on  $n$  vertices, for  $n \geq 3$ , is  $(1/2)(2^{n-3} + 2^{\lfloor (n-3)/2 \rfloor})$ .

19. (a) 1, -1, 1, 1, -1, -1

1, 1, -1, 1, -1, -1

1, -1, 1, -1, 1, -1

(b)

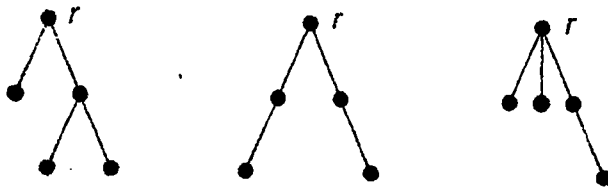

In total there are 14 ordered rooted trees on five vertices.

(c) This is another example where the Catalan numbers arise. There are  $\left(\frac{1}{n+1}\right)\binom{2n}{n}$  ordered rooted trees on  $n + 1$  vertices.

20. (a) Consider the case for  $n = 4$ , shown in part (a) of the figure. The five spanning subgraphs in parts (b)–(f) of the figure provide pairwise mutually exclusive situations that account for all the spanning trees of the graph given in part (a). As we scan the figure from left to right we find that

$$t_4 = t_3 + t_3 + t_2 + t_1 + t_0 = t_3 + \sum_{i=0}^3 t_i.$$

This result generalizes to provide  $t_{n+1} = t_n + \sum_{i=0}^n t_i$ .

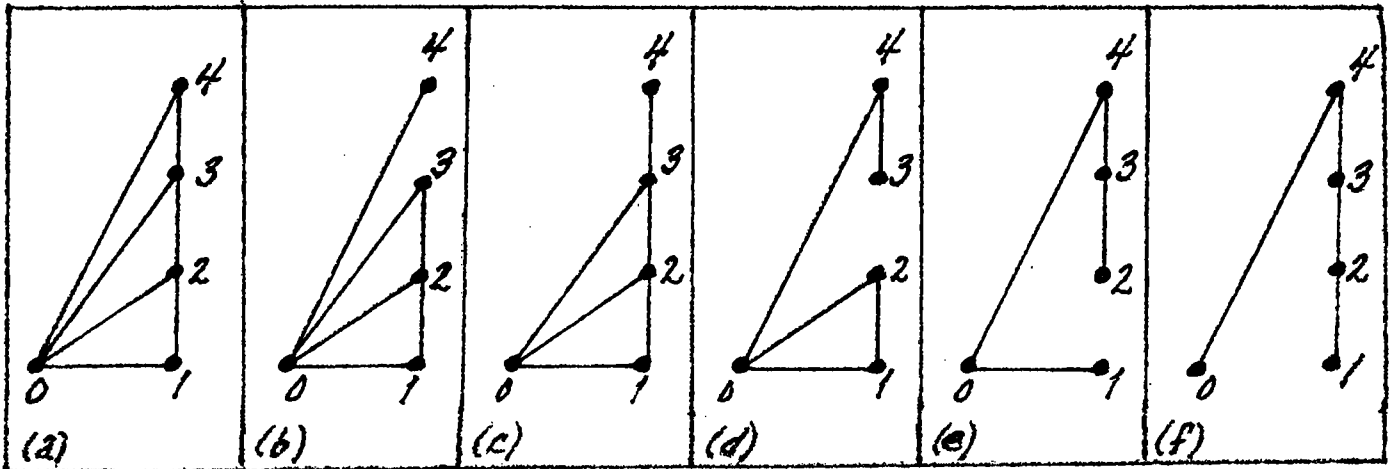

(b)

$$\begin{aligned} t_{n+1} &= t_n + \sum_{i=0}^n t_i \\ &= 2t_n + \sum_{i=0}^{n-1} t_i \\ &= 2t_n + [t_{n-1} + \sum_{i=0}^{n-1} t_i] - t_{n-1} \\ &= 3t_n - t_{n-1}, n \geq 2 \end{aligned}$$

$$(c) \quad t_{n+1} = 3t_n - t_{n-1}, n \geq 2, t_2 = 3, t_1 = 1.$$

$$\text{Let } t_n = Ar^n, A \neq 0, r \neq 0.$$

$$r^2 - 3r + 1 = 0$$

$$r = (3 \pm \sqrt{5})/2$$

$$\text{So } t_n = B[(3 + \sqrt{5})/2]^n + C[(3 - \sqrt{5})/2]^n.$$

$$\text{Since } 1 = t_1 = B[(3 + \sqrt{5})/2] + C[(3 - \sqrt{5})/2] \text{ and}$$

$$3 = t_2 = B[(3 + \sqrt{5})/2]^2 + C[(3 - \sqrt{5})/2]^2,$$

we find that

$$B = 1/\sqrt{5}, C = -1/\sqrt{5}.$$

$$\text{Consequently, } t_n = (1/\sqrt{5})[(3 + \sqrt{5})/2]^n - (1/\sqrt{5})[(3 - \sqrt{5})/2]^n, n \geq 1, t_0 = 1.$$

Recall that the  $n$ th Fibonacci number  $F_n$  is given by

$$F_n = (1/\sqrt{5})[(1 + \sqrt{5})/2]^n - (1/\sqrt{5})[(1 - \sqrt{5})/2]^n, n \geq 0.$$

$$\text{For } n \geq 1, F_{2n} = (1/\sqrt{5})[(1 + \sqrt{5})/2]^{2n} - (1/\sqrt{5})[(1 - \sqrt{5})/2]^{2n} = (1/\sqrt{5})[(1 + \sqrt{5})^2/4]^n - (1/\sqrt{5})[(1 - \sqrt{5})^2/4]^n = (1/\sqrt{5})[(3 + \sqrt{5})/2]^n - (1/\sqrt{5})[(3 - \sqrt{5})/2]^n = t_n.$$

21. (a) There are  $\binom{5}{3} - 2 = 8$  nonidentical (though some are isomorphic) spanning trees for the kite induced by  $a, b, c, d$ . Since there are four vertices, a spanning tree has three edges and the only selections of three edges that do not provide a spanning tree are  $\{a, c\}, \{b, c\}, \{a, b\}$  and  $\{a, b\}, \{a, d\}, \{b, d\}$ .

(b) There are  $8 \cdot 1 \cdot 8 \cdot 1 \cdot 8 \cdot 1 \cdot 8 = 8^4$  nonidentical (though some are isomorphic) spanning trees of  $G$  that do not contain edge  $\{c, h\}$ . These spanning trees must include the edges  $\{g, k\}, \{l, p\}$ , and  $\{d, o\}$ , and there are eight nonidentical (though some are isomorphic) spanning trees for each of the four subgraphs that are kites.

(c) Consider the kite induced by  $a, b, c, d$ . There are eight two-tree forests for this kite that have no path between  $c$  and  $d$ . These forests can be obtained from the five edges of the kite by removing three edges at a time, as follows:

- |                                      |                                       |
|--------------------------------------|---------------------------------------|
| (i) $\{a, b\}, \{a, c\}, \{b, c\}$   | (ii) $\{a, c\}, \{b, c\}, \{b, d\}$   |
| (iii) $\{a, c\}, \{a, d\}, \{b, c\}$ | (iv) $\{a, b\}, \{a, d\}, \{b, d\}$   |
| (v) $\{a, d\}, \{b, c\}, \{b, d\}$   | (vi) $\{a, c\}, \{a, d\}, \{b, d\}$   |
| (vii) $\{a, b\}, \{a, d\}, \{b, c\}$ | (viii) $\{a, b\}, \{a, c\}, \{b, d\}$ |

Vertex  $c$  is isolated for (i), (ii), (iii). For (iv), (v), (vi), vertex  $d$  is isolated. The forests for (vii), (viii) each contain two disconnected edges:  $\{a, c\}, \{b, d\}$  for (vii) and  $\{a, d\}, \{b, c\}$  for (viii).

Consequently, there are  $4 \cdot 8 \cdot 1 \cdot 8 \cdot 1 \cdot 8 \cdot 1 \cdot 8 \cdot 1 = 4 \cdot 8^4$  nonidentical (though some are isomorphic) spanning trees for  $G$  that contain each of the four edges  $\{c, h\}, \{g, k\}, \{l, p\}$ , and  $\{d, o\}$ .

(d) In total there are  $4 \cdot 8^4 + 4 \cdot 8^4 = 2(4 \cdot 8^4)$  nonidentical (though some are isomorphic) spanning trees for  $G$ .

(e)  $2n8^n$

CHAPTER 13  
OPTIMIZATION AND MATCHING

**Section 13.1**

1. (a) If not, let  $v_i \in \bar{S}$ , where  $1 \leq i \leq m$  and  $i$  is the smallest such subscript. Then  $d(v_0, v_i) < d(v_0, v_{m+1})$ , and we contradict the choice of  $v_{m+1}$  as a vertex  $v$  in  $\bar{S}$  for which  $d(v_0, v)$  is a minimum.
 

(b) Suppose there is a shorter directed path (in  $G$ ) from  $v_0$  to  $v_k$ . If this path passes through a vertex in  $\bar{S}$ , then from part (a) we have a contradiction. Otherwise, we have a shorter directed path  $P''$  from  $v_0$  to  $v_k$  and  $P''$  only passes through vertices in  $S$ . But then  $P'' \cup \{(v_k, v_{k+1}), (v_{k+1}, v_{k+2}), \dots, (v_{m-1}, v_m), (v_m, v_{m+1})\}$  is a directed path (in  $G$ ) from  $v_0$  to  $v_{m+1}$ , and it is shorter than path  $P$ .

2.

- (a) Initialization: (Counter = 0)  $a = v_0$ ,  $S_0 = \{a\}$ . Label  $a$  with  $(0, -)$  and the other six vertices with  $(\infty, -)$ .

First Iteration:  $\bar{S}_0 = \{b, c, f, g, h, i\}$   
 $L(b) = 14$ ,  $L(g) = 10$ ,  $L(h) = 17$ .  
 So we have the labels:  $g : (10, a)$ ;  $b : (14, a)$ ;  $h : (17, a)$ .  
 $L(v) = \infty$  for  $v = c, f$ , and  $i$ . Hence  $v_1 = g$ ,  $S_1 = \{a, g\}$   
 and the counter is increased to 1.

Second Iteration:  $\bar{S}_1 = \{b, c, f, h, i\}$   
 $L(b) = 13 = L(g) + wt(g, b) < 14$ , so  $b$  is now labeled  $(13, g)$ .  
 $L(h) = 16 = L(g) + wt(g, h) < 17$ , so  $h$  is now labeled  $(16, g)$ .  
 $L(i) = 14 = L(g) + wt(g, i) < \infty$ , so  $i$  now has the label  $(14, g)$ .

The vertices  $c, f$  are still labeled by  $(\infty, -)$ . Now we find  $v_2 = b$  and we set  $S_2 = \{a, g, b\}$  and increase the counter to 2.

Third Iteration:  $\bar{S}_2 = \{c, f, h, i\}$   
 $L(c) = 22 = L(b) + wt(b, c)$  and  $c$  is labeled  $(22, b)$ .  
 $L(f) = 23 = L(b) + wt(b, f)$  and  $f$  is labeled  $(23, b)$ .  
 $L(h) = 16$  and  $h$  is labeled  $(16, g)$ .  
 $L(i) = 14$  and  $i$  is labeled  $(14, g)$ .  
Now we have  $v_3 = i$  with  $S_3 = \{a, g, b, i\}$  and the counter is increased to 3.

Fourth Iteration:  $\bar{S}_3 = \{c, f, h\}$   
 $L(c) = 22$  and  $c$  is labeled  $(22, b)$ .  
 $L(h) = 15 = L(i) + wt(i, h) < 16$  and  $h$  is labeled  $(15, i)$ .  
 $L(f) = 21 = L(i) + wt(i, f) < 23$  and  $f$  is labeled  $(21, i)$ .  
Here we have  $v_4 = h$ ,  $S_4 = \{a, g, b, i, h\}$  and counter is now assigned the value 4.

Fifth Iteration:  $\bar{S}_4 = \{c, f\}$   
 $L(c) = 22$  and  $c$  is labeled  $(22, b)$ .  
 $L(f) = 21$  and  $f$  is labeled  $(21, i)$ .  
Now  $v_5 = f$ ,  $S_5 = \{a, g, b, i, h, f\}$  and the counter is increased to 5.

Sixth Iteration:  $\bar{S}_5 = \{c\}$   
 $L(c) = 22$  and  $c$  is labeled  $(22, b)$ .  
Here  $v_6 = c$ ,  $S_6 = \{a, g, b, i, h, f, c\}$ , and now counter =  $6 = 7 - 1 = |V| - 1$ , so the algorithm terminates.

(b)  $c: \{a, g\}, \{g, b\}, \{b, c\}$        $f: \{a, g\}, \{g, i\}, \{i, f\}$        $i: \{a, g\}, \{g, i\}$

3. (a)  $d(a, b) = 5; d(a, c) = 6; d(a, f) = 12; d(a, g) = 16; d(a, h) = 12$   
(b)  $f: \{(a, c), (c, f)\}$        $g: \{(a, b), (b, h), (h, g)\}$   
 $h: \{(a, b), (b, h)\}$

4. (a) Order the vertices of  $G$  as  $[a, b, c, f, g, h]$ .

For  $L_0$  we get the following array of labels:  $[\infty, \infty, 0, \infty, \infty, \infty]$ , and  $S_0 = \{c\}$ .

In a similar manner we obtain the arrays:

$L_1: [\infty, \infty, 0, 6, \infty, 11]; S_1 = \{c, f\}$   
 $L_2: [11, \infty, 0, 6, 15, 10]; S_2 = \{c, f, h\}$   
 $L_3: [17, \infty, 0, 6, 14, 10]; S_3 = \{c, f, h, g\}$   
 $L_4: [17, \infty, 0, 6, 14, 10]; S_4 = \{c, f, h, g, a\}$   
 $L_5: [17, 22, 0, 6, 14, 10]; S_5 = \{c, f, h, g, a, b\}$

- (b) Order the vertices of  $G$  as  $[a, b, c, f, g, h, i]$ .

We obtain the following arrays for the six iterations:

- $L_0 : [0, \infty, \infty, \infty, \infty, \infty, \infty]; S_0 = \{a\}$   
 $L_1 : [0, 14, \infty, \infty, 10, 17, \infty]; S_1 = \{a, g\}$   
 $L_2 : [0, 13, \infty, \infty, 10, 16, 14]; S_2 = \{a, g, b\}$   
 $L_3 : [0, 13, 22, 23, 10, 16, 14]; S_3 = \{a, g, b, i\}$   
 $L_4 : [0, 13, 22, 21, 10, 15, 14]; S_4 = \{a, g, b, i, h\}$   
 $L_5 : [0, 13, 22, 21, 10, 15, 14]; S_5 = \{a, g, b, i, h, f\}$   
 $L_6 : [0, 13, 22, 21, 10, 15, 14]; S_6 = \{a, g, b, i, h, f, c\}$

5. False – consider the weighted graph

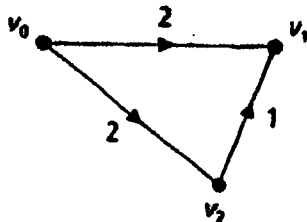

### Section 13.2

1. Kruskal's Algorithm generates the following sequence (of forests) which terminates in a minimal spanning tree  $T$  of weight 18:

- |                                    |  |
|------------------------------------|--|
| (1) $F_1 = \{\{e, h\}\},$          | (2) $F_2 = F_1 \cup \{\{a, b\}\},$     |
| (3) $F_3 = F_2 \cup \{\{b, c\}\},$ | (4) $F_4 = F_3 \cup \{\{d, e\}\},$     |
| (5) $F_5 = F_4 \cup \{\{e, f\}\},$ | (6) $F_6 = F_5 \cup \{\{a, e\}\},$     |
| (7) $F_7 = F_6 \cup \{\{d, g\}\},$ | (8) $F_8 = T = F_7 \cup \{\{f, i\}\}.$ |

Note: The answer given here is not unique.

2.

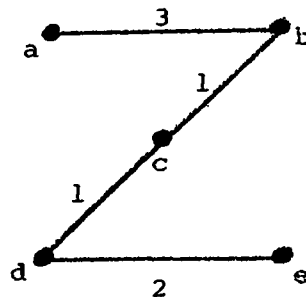
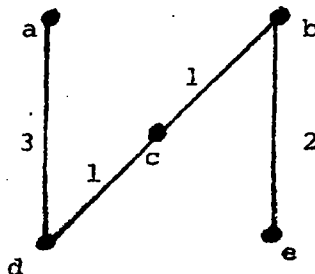
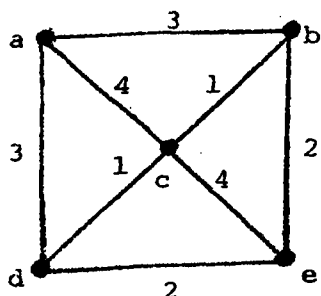
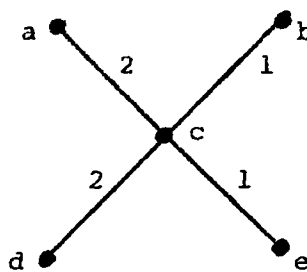
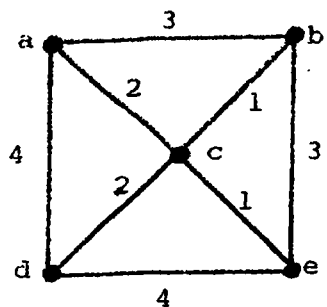

3. No! Consider the following counterexample:

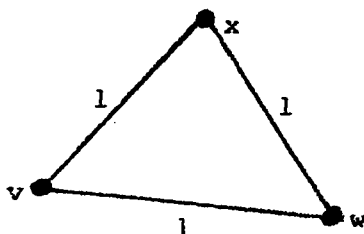

Here  $V = \{v, x, w\}$ ,  $E = \{\{v, x\}, \{x, w\}, \{v, w\}\}$  and  $E' = \{\{v, x\}, \{x, w\}\}$ .

4. Gary – South Bend (58); South Bend – Fort Wayne (79); Fort Wayne – Indianapolis (121); Indianapolis – Bloomington (151); Bloomington – Terre Haute (58); Terre Haute – Evansville (113).

5. (a) Evansville – Indianapolis (168); Bloomington – Indianapolis (51); South Bend – Gary (58); Terre Haute – Bloomington (58); South Bend – Fort Wayne (79); Indianapolis – Fort Wayne (121).

(b) Fort Wayne – Gary (132); Evansville – Indianapolis (168); Bloomington – Indianapolis (51); Gary – South Bend (58); Terre Haute – Bloomington (58); Indianapolis – Fort Wayne (121).

6. Start with the prescribed edge(s), unless one or more cycles result. (If so, delete the edge of maximum weight in each such cycle.) Then apply Kruskal's Algorithm starting at Step (2).

7. (a) To determine an optimal tree of maximal weight replace the two occurrences of "small" in Kruskal's Algorithm by "large".

(b) Use the edges: South Bend – Evansville (303); Fort Wayne – Evansville (290); Gary –

Evansville (277); Fort Wayne – Terre Haute (201); Gary – Bloomington (198); Indianapolis – Evansville (168).

8. The proof for Prim's Algorithm is similar to that of Kruskal's Algorithm.

Proof: Let  $|V| = n$ , and let  $T$  be a spanning tree for  $G$  obtained by Prim's Algorithm. The edges in  $T$  are labeled as  $e_1, e_2, \dots, e_{n-1}$ , where the subtree  $S_i$  of  $T$ , obtained after the  $i$ th iteration of the algorithm, contains the edges  $e_1, e_2, \dots, e_i$ , for some  $1 \leq i \leq n-1$ . For each optimal tree  $T'$  of  $G$  define  $d(T')$ , as in the proof of Theorem 13.1. Let  $T_1$  be an optimal tree for  $G$  where  $d(T_1) = r$  is maximal. We shall prove that  $T = T_1$ .

If not, then  $r < n-1$ , and there exists an edge  $e_r = \{x, y\}$  with  $e_r \in T, e_r \notin T_1$ . Since  $T_1$  is a spanning tree for  $G$ , however, there is a unique path  $P$  connecting  $x$  and  $y$  in  $T_1$ . Assume that  $x \in S_{r-1}, y \notin S_{r-1}$ . Select an edge  $e'_r$  in  $P$  which joins a vertex in  $S_{r-1}$  with a vertex that is not in  $S_{r-1}$ . By the minimality condition in Step 2 of Prim's Algorithm  $wt(e'_r) \geq wt(e_r)$ . Adding the edge  $e_r$  to  $T_1$ ,  $e_r$  together with the edges in  $P$  form a cycle. Deleting edge  $e'_r$ , the cycle becomes a path and a new subgraph of  $G$  is obtained. Since this subgraph is connected with  $n$  vertices and  $n-1$  edges, it is a tree  $T_2$ , where  $wt(T_2) = wt(T_1) + wt(e_r) - wt(e'_r)$ . With  $wt(e'_r) \geq wt(e_r)$ , we find that  $wt(T_2) \leq wt(T_1)$ , and since  $T_1$  is optimal it follows that  $wt(T_2) = wt(T_1)$ . But then  $T_2$  is an optimal tree for the graph  $G$  with  $d(T_2) > r$ , and this contradicts the choice of  $T_1$  (where  $d(T_1)$  is maximal).

9. When the weights of the edges are all distinct, in each step of Kruskal's Algorithm a unique edge is selected.

### Section 13.3

1. (a)  $s = 2; t = 4; w = 5; x = 9; y = 4$  (b) 18

- (c) (i)  $P = \{a, b, h, d, g, i\}; \bar{P} = \{z\}$   
 (ii)  $P = \{a, b, h, d, g\}; \bar{P} = \{i, z\}$   
 (iii)  $P = \{a, h\}; \bar{P} = \{b, d, g, i, z\}$

2. Corollary 13.3: This result is a special case of Theorem 13.3.

Corollary 13.4: This result follows from the observation following the proof of Theorem 13.3, namely,

$$val(f) = \sum_{\substack{x \in P \\ y \in \bar{P}}} f(x, y) - \sum_{\substack{v \in P \\ w \in \bar{P}}} f(v, w).$$

If  $val(f) = c(P, \bar{P}) = \sum_{\substack{x \in P \\ y \in \bar{P}}} c(x, y)$ , since  $0 \leq f(x, y) \leq c(x, y)$ , for

$x \in P, y \in \bar{P}$ , it follows that  $f(e) = c(e)$  for each  $e = (x, y), x \in P, y \in \bar{P}$ , and

$f(e) = 0$  for each  $e = (v, w)$ ,  $v \in \bar{P}$ ,  $w \in P$ . Conversely if conditions (a) and (b) hold, then

$$\text{val}(f) = \sum_{\substack{x \in P \\ y \in P}} f(x, y) - \sum_{\substack{w \in P \\ v \in P}} f(v, w) = \sum_{\substack{x \in P \\ y \in P}} c(x, y) - 0 = c(P, \bar{P}).$$

3. (1)

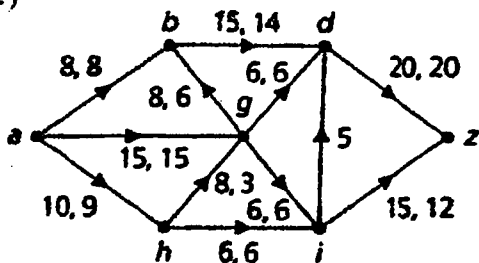

(2)

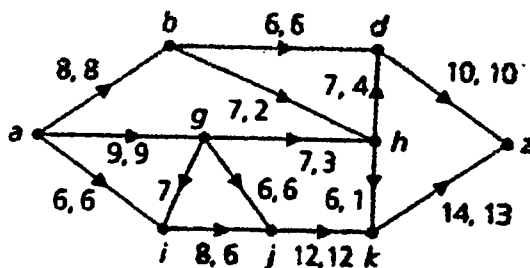

The maximal flow is 32, which is  $c(P, \bar{P})$  for  $P = \{a, b, d, g, h\}$  and  $\bar{P} = \{i, z\}$ .

The maximal flow is 23, which is  $c(P, \bar{P})$  for  $P = \{a\}$  and  $\bar{P} = \{b, g, i, j, d, h, k, z\}$ .

4. (Example 13.12)

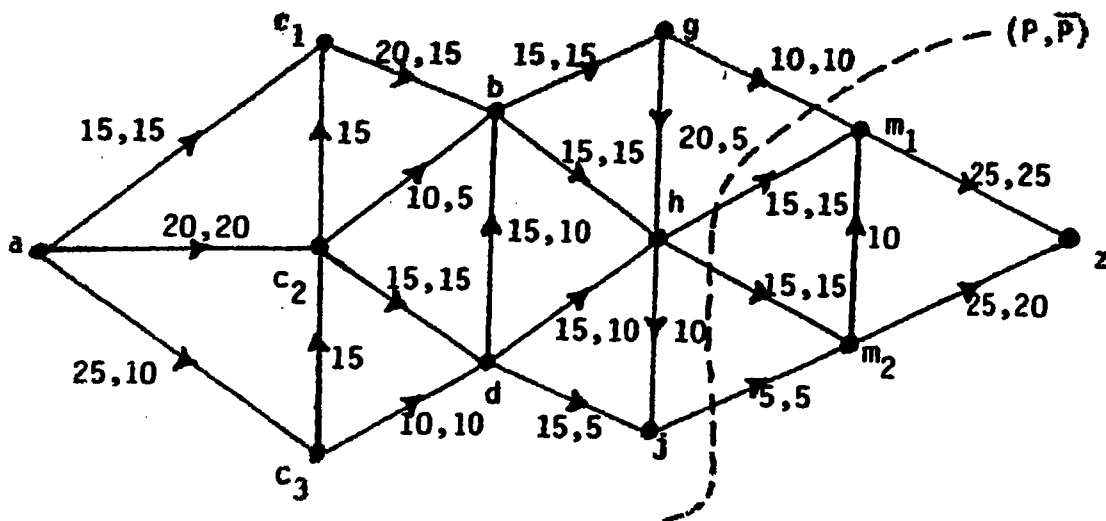

(Example 13.13)

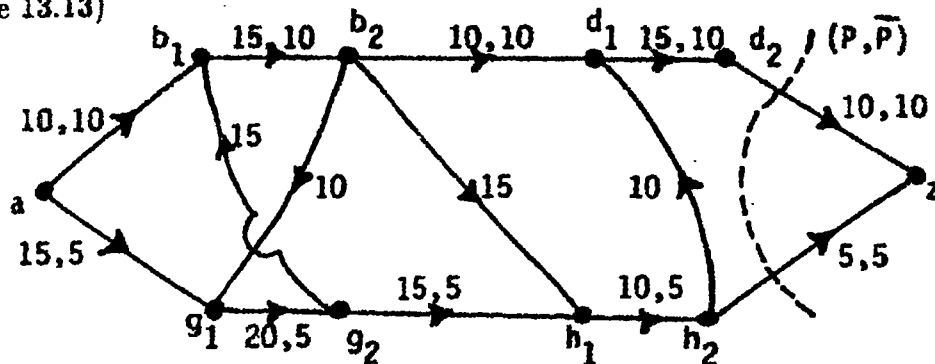

(Example 13.14) Four messengers should be sent out – one for each of the following paths (which are mutually disjoint in pairs).

(1)  $a \rightarrow b \rightarrow h \rightarrow p \rightarrow z$

(2)  $a \rightarrow d \rightarrow i \rightarrow m \rightarrow q \rightarrow z$

(3)  $a \rightarrow f \rightarrow j \rightarrow n \rightarrow r \rightarrow z$

(4)  $a \rightarrow g \rightarrow k \rightarrow s \rightarrow z$

5. Here  $c(e)$  is a positive integer for each  $e \in E$  and the initial flow is defined as  $f(e) = 0$  for all  $e \in E$ . The result follows because  $\Delta_p$  is a positive integer for each application of the Edwards-Karp algorithm and, in the Ford-Fulkerson algorithm,  $f(e) - \Delta_p$  will not be negative for a backward edge.

6. (a)

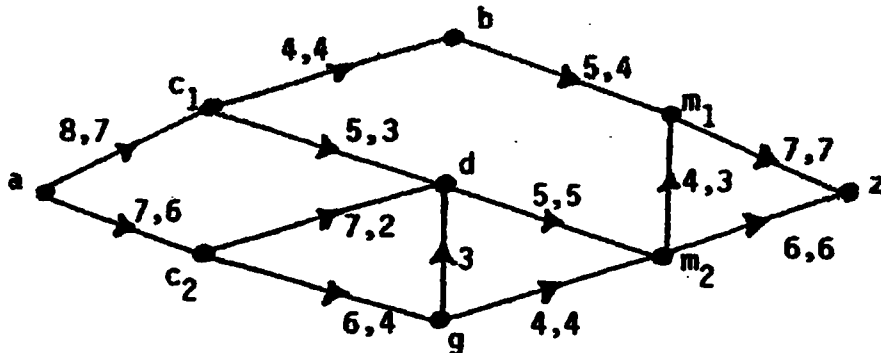

- (b)

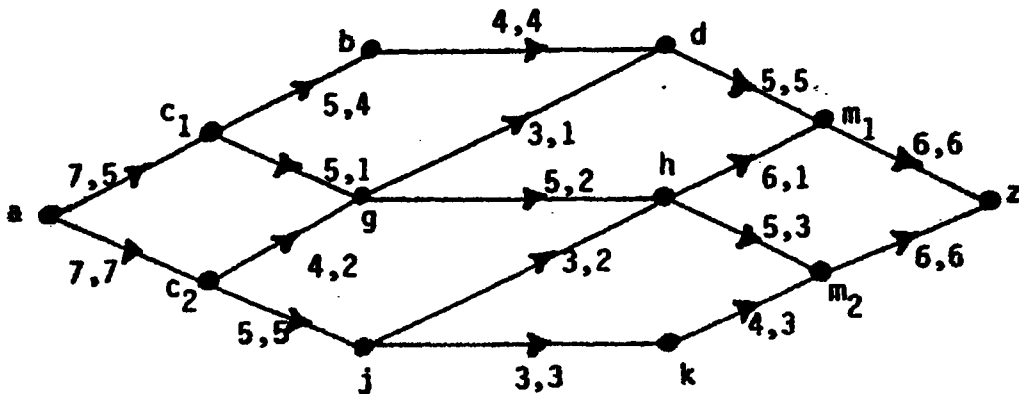

In either situation the supply will meet the manufacturers' demands.

- 7.

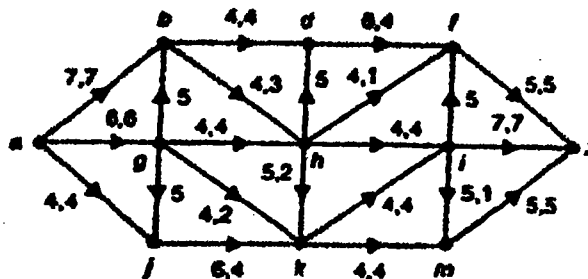



$$\begin{aligned}
&= (2n-1)(2n-3)(2n-5)\cdots(5)(3)(1) = \frac{(2n)(2n-1)(2n-2)(2n-3)\cdots(4)(3)(2)(1)}{(2n)(2n-2)\cdots(4)(2)} \\
&= \frac{(2n)!}{2^n(n!)}
\end{aligned}$$

6. (Corollary 13.6) Let  $A \subseteq X$ . Since  $\deg(x) \geq k$  for all  $x \in X$ , there are at least  $k|A|$  edges that are incident from the vertices in  $A$ . These edges are incident to  $|R(A)|$  vertices in  $Y$ . Since  $\deg(y) \leq k$  for all  $y \in Y$ , it follows that  $k|A| \leq k|R(A)|$ , so we have  $|A| \leq |R(A)|$ , and there is a complete matching of  $X$  into  $Y$  (by virtue of Theorem 13.7).
7. Yes, such an assignment can be made by Fritz. Let  $X$  be the set of student applicants and  $Y$  the set of part-time jobs. Then for all  $x \in X$ ,  $y \in Y$ , draw the edge  $(x, y)$  if applicant  $x$  is qualified for part-time job  $y$ . Then  $\deg(x) \geq 4 \geq \deg(y)$  for all  $x \in X$ ,  $y \in Y$ , and the result follows from Corollary 13.6.
8. (a)  $4 \in A_1, 3 \in A_2, 1 \in A_3, 2 \in A_4$ .  
 (b)  $2 \in A_1, 4 \in A_2, 5 \in A_3, 1 \in A_4, 3 \in A_5$ .  
 (c) Since  $|\cup_{i=1}^5 A_i| = 4 < 5$ , there is no system of distinct representatives.
9. (a) (1) Select  $i$  from  $A_i$ , for  $1 \leq i \leq 4$ .  
 (2) Select  $i+1$  from  $A_i$ , for  $1 \leq i \leq 3$ , and 1 from  $A_4$ .  
 (b) 2
10. (a) If there is a system of distinct representatives then  $|\cup_{i=1}^n A_i| \geq n$ , i.e.,  $k \geq n$ , since  $|\cup_{i=1}^n A_i| = |A_i| = k$ , for all  $1 \leq i \leq n$ . Conversely, if there is no system of distinct representatives, then for some  $1 \leq i \leq n$ , the union of  $i$  of the sets  $A_1, A_2, \dots, A_n$  contains less than  $i$  elements. Hence  $k < i \leq n$ , or  $k < n$ .  
 (b)  $P(k, n)$ .
11. Proof: For each subset  $A$  of  $X$ , let  $G_A$  be the subgraph of  $G$  induced by the vertices in  $A \cup R(A)$ . If  $e$  is the number of edges in  $G_A$ , then  $e \geq 4|A|$  because  $\deg(a) \geq 4$  for all  $a \in A$ . Likewise  $e \leq 5|R(A)|$  because  $\deg(b) \leq 5$  for all  $b \in R(A)$ . So  $5|R(A)| \geq 4|A|$  and  $\delta(A) = |A| - |R(A)| \leq |A| - (4/5)|A| = (1/5)|A| \leq (1/5)|X| = 2$ . Then since  $\delta(G) = \max\{\delta(A) | A \subseteq X\}$  we have  $\delta(G) \leq 2$ .
12. Let  $\emptyset \neq A \subseteq X$  and  $E_1 \subseteq E$  where  $E_1 = \{\{a, b\} | a \in A, b \in R(A)\}$ . Since  $\deg(a) \geq 3$  for all  $a \in A$ ,  $|E_1| \geq 3|A|$ . For each  $b \in R(A) \subseteq Y$ ,  $\deg(b) \leq 7$ , so  $|E_1| \leq 7|R(A)|$ . Hence  $3|A| \leq 7|R(A)|$  and  $\delta(A) = |A| - |R(A)| \leq |A| - (3/7)|A| = (4/7)|A|$ . Since  $|X| \leq 50$  and  $A \subseteq X$ ,  $\delta(A) \leq (4/7)(50) = 200/7$  and  $\delta(G) = \max\{\delta(A) | A \subseteq X\} \leq 28$ .
13. (a)  $\delta(G) = 1$ . A maximal matching of  $X$  into  $Y$  is given by  $\{\{x_1, y_4\}, \{x_2, y_3\}, \{x_3, y_1\}, \{x_5, y_3\}\}$ .

(b) If  $\delta(G) = 0$ , there is a complete matching of  $X$  into  $Y$ , and  $\beta(G) = |Y|$ , or  $|Y| = \beta(G) - \delta(G)$ . If  $\delta(G) = k > 0$ , let  $A \subseteq X$  where  $|A| - |R(A)| = k$ . Then  $A \cup (Y - R(A))$  is a largest maximal independent set in  $G$  and  $\beta(G) = |A| + |Y - R(A)| = |Y| + (|A| - |R(A)|) = |Y| + \delta(G)$ , so  $|Y| = \beta(G) - \delta(G)$ .

(c) Figure 13.30 (a):  $\{x_1, x_2, x_3, y_2, y_4, y_5\}$ ;

Figure 13.32:  $\{x_3, x_4, y_2, y_3, y_4\}$ .

14. Proof (By Mathematical Induction):

The hypercube  $Q_2$  has vertex set  $V = \{00, 01, 10, 11\}$  and edge set  $E = \{\{00, 01\}, \{01, 11\}, \{11, 10\}, \{10, 00\}\}$ . Here there are two perfect matchings:  $\{\{10, 00\}, \{11, 01\}\}$  and  $\{\{10, 11\}, \{00, 01\}\}$ . So the result is true in this first case, where  $n = 2$ .

Assume the result is true for  $n = k (\geq 2)$  - that is, that  $Q_k$  has at least  $2^{(2^{k-2})}$  perfect matchings. Now consider the case for  $n = k + 1$ . In dealing with the hypercube  $Q_{k+1}$ , consider the subgraphs induced by the two sets of vertices  $V^{(i)} = \{v | v \text{ is a vertex in } Q_{k+1} \text{ with first component } i\}$ ,  $i = 0, 1$ . The subgraph of  $Q_{k+1}$  induced by  $V^{(0)}$  is (isomorphic to)  $Q_k$  - likewise, for the subgraph induced by  $V^{(1)}$ . From the induction hypothesis each of these subgraphs has at least  $2^{(2^{k-2})}$  perfect matchings. Since the two subgraphs have no common edges, it follows from the rule of product that  $Q_{k+1}$  has at least  $2^{(2^{k-2})} \cdot 2^{(2^{k-2})} = 2^{(2^{k-2} + 2^{k-2})} = 2^{2(2^{k-2})} = 2^{2^{(k+1)-2}}$  perfect matchings.

The result now follows for all  $n \geq 2$  by the Principle of Mathematical Induction.

### Supplementary Exercises

1.  $d(a, b) = 5$ ;  $d(a, c) = 11$ ;  $d(a, d) = 7$ ;  $d(a, e) = 8$ ;  
 $d(a, f) = 19$ ;  $d(a, g) = 9$ ;  $d(a, h) = 14$

(Note that the loop at vertex  $g$  and the edges  $(c, a)$  of weight 9 and  $(f, e)$  of weight 5 are of no significance.)

2. The algorithm is not correct. The following weighted directed graph provides a counterexample.

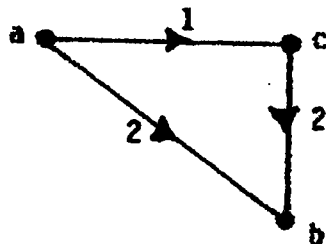

3. (a) The edge  $e_1$  will always be selected in the first step of Kruskal's Algorithm.  
 (b) Again using Kruskal's Algorithm, edge  $e_2$  will be selected in the first application of Step (2) unless each of the edges  $e_1, e_2$  is incident with the same two vertices, i.e., the

edges  $e_1, e_2$  form a circuit and  $G$  is a multigraph.

4. (a) In applying Kruskal's Algorithm, the only way we would have to consider edge  $e_1$  as our last choice is if there is a vertex  $v$  in the graph where  $e_1 = \{w, v\}$  and  $v$  is a pendant vertex of  $G$ . This cannot happen here since  $e_1$  is part of a cycle.

(b) This result is false. Let  $G$  be the graph  $K_3$  where the edges are assigned the weights  $wt(e_1) = 3, wt(e_2) = 2, wt(e_3) = 1$ .

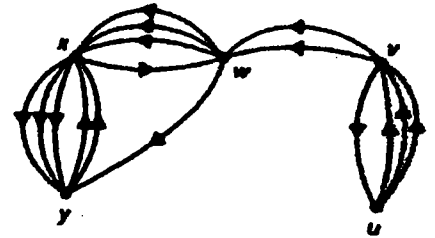
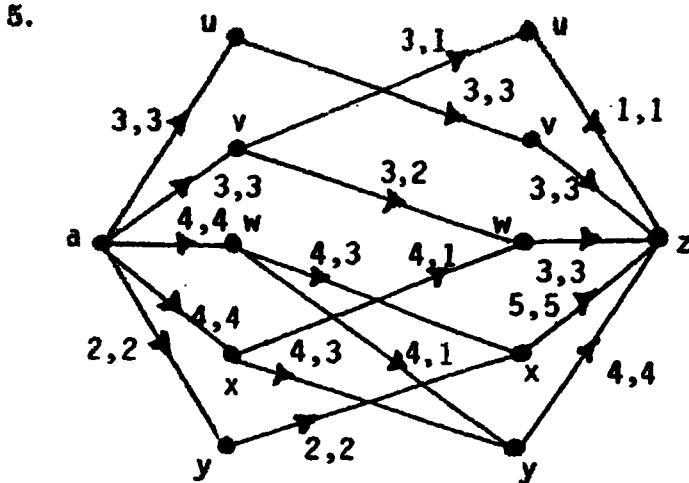

The transport network in the first diagram is determined by using the in degrees of the vertices for the capacities of the edges terminating at the sink  $z$ ; the out degrees of the vertices are used for the capacities of the edges that originate at the source  $a$ .

6. (a) One possible selection is  $qs : q; tq : t; ut : u; pqr : p; srt : r$ .

(b) There are nine selections that each determine a system of distinct representatives. Consequently, the probability that the selection yields a system of distinct representatives is  $9/[(2^3)(3^2)]$ .

7. The number of different systems of distinct representatives is  $d_n$ , the number of derangements of  $\{1, 2, 3, \dots, n\}$ .

8. (a)  $5!$ ;  $n!$

(b) Each entry in  $B$  is nonnegative and the sum of the entries in each row or column is 1.

(c)

$$B = (0.1) \begin{bmatrix} 0 & 1 & 0 \\ 0 & 0 & 1 \\ 1 & 0 & 0 \end{bmatrix} + (0.2) \begin{bmatrix} 1 & 0 & 0 \\ 0 & 1 & 0 \\ 0 & 0 & 1 \end{bmatrix} + (0.3) \begin{bmatrix} 0 & 0 & 1 \\ 0 & 1 & 0 \\ 1 & 0 & 0 \end{bmatrix} + (0.4) \begin{bmatrix} 0 & 0 & 1 \\ 1 & 0 & 0 \\ 0 & 1 & 0 \end{bmatrix}$$

(d) The  $r$  rows of  $B$  sum to  $r$ , since each row of  $B$  sums to 1. When we add the

entries, considered in  $s$  columns, we get a result of  $s$  if we are dealing with all of the entries in the  $s$  columns. Hence here the entries sum to a number less than or equal to  $s$ . Consequently we have both  $r > s$  and  $r \leq s$ , a contradiction.

Since this is a complete matching of  $X$  into  $Y$  we have  $n$  edges of the form  $\{x_i, y_j\}$ , where each of  $x_i$  and  $y_j$ ,  $1 \leq i, j \leq n$ , appears exactly once. These edges are determined by the  $n$  nonnegative numbers  $b_{ij}$ , where no two of these numbers are in the same row or column of  $B$ . Writing  $B = c_1 P_1 + B_1$  where  $c_1$  is the smallest entry in  $B$  and  $P_1$  is an  $n \times n$  permutation matrix, the sums of the entries in each row and column of  $B_1$  is  $1 - c_1$ , where  $0 \leq 1 - c_1 < 1$ .

(e) We now repeat the argument in part (d) for the matrix  $B_1$  and get  $B = c_1 P_1 + c_2 P_2 + B_2$ , where the sum of the entries in each row and column of  $B_2$  is  $1 - c_1 - c_2$ , where  $0 \leq 1 - c_1 - c_2 < 1 - c_1$ . This process is continued until we obtain  $B = c_1 P_1 + c_2 P_2 + \dots + c_k P_k + B_k$  where all entries in  $B_k$  are 0.

9. The vertices (in the line graph  $L(G)$ ) determined by  $E'$  form a maximal independent set.

PART 4

MODERN

APPLIED

ALGEBRA

CHAPTER 14  
RINGS AND MODULAR ARITHMETIC

**Section 14.1**

1. (Example 14.5):  $-a = a, -b = e, -c = d, -d = c, -e = b$   
 (Example 14.6):  $-s = s, -t = y, -v = x, -w = w, -x = v, -y = t$
2. (a) This set is not a ring under ordinary addition and multiplication because there are no additive inverses.  
 (c) and (d) These sets are rings under ordinary addition and multiplication.  
 (d) This set is not a ring because it is not closed under multiplication.

3.
 

(a)	$(a + b) + c$	=	$(b + a) + c$	Commutative Law of +
			$= b + (a + c)$	Associative Law of +
			$= b + (c + a)$	Commutative Law of +
(b)	$d + a(b + c)$	=	$d + (ab + ac)$	Distributive Law of $\cdot$ over +
			$= (d + ab) + ac$	Associative Law of +
			$= (ab + d) + ac$	Commutative Law of +
			$= ab + (d + ac)$	Associative Law of +
(c)	$c(d + b) + ab$	=	$ab + c(d + b)$	Commutative Law of +
			$= ab + (cd + cb)$	Distributive Law of $\cdot$ over +
			$= ab + (cb + cd)$	Commutative Law of +
			$= (ab + cb) + cd$	Associative Law of +
			$= (a + c)b + cd$	Distributive Law of $\cdot$ over +
(d)	$a(bc) + (ab)d$	=	$(ab)c + (ab)d$	Associate Law of $\cdot$
			$= (ab)(c + d)$	Distributive Law of $\cdot$ over +
			$= (ab)(d + c)$	Commutative Law of +

4. No. Although there is an identity for this definition of  $+$ , namely  $\emptyset$ , there are no additive inverses.
5. (a) (i) The closed binary operation  $\oplus$  is associative. For all  $a, b, c \in \mathbf{Z}$  we find that

$$(a \oplus b) \oplus c = (a + b - 1) \oplus c = (a + b - 1) + c - 1 = a + b + c - 2,$$

and

$$a \oplus (b \oplus c) = a \oplus (b + c - 1) = a + (b + c - 1) - 1 = a + b + c - 2.$$

(ii) For the closed binary operation  $\odot$  and all  $a, b, c \in \mathbf{Z}$ , we have

$$(a \odot b) \odot c = (a + b - ab) \odot c = (a + b - ab) + c - (a + b - ab)c = a + b - ab + c - ac - bc + abc = a + b + c - ab - ac - bc + abc; \text{ and}$$

$$a \odot (b \odot c) = a \odot (b + c - bc) = a + (b + c - bc) - a(b + c - bc) = a + b + c - bc - ab - ac + abc = a + b + c - ab - ac - bc + abc.$$

Consequently, this closed binary operation is also associative.

(iii) Given any integers  $a, b, c$ , we find that

$$(b \oplus c) \odot a = (b + c - 1) \odot a = (b + c - 1) + a - (b + c - 1)a = b + c - 1 + a - ba - ca + a = 2a + b + c - 1 - ba - ca, \text{ and}$$

$$(b \odot a) \oplus (c \odot a) = (b + a - ba) \oplus (c + a - ca) = (b + a - ba) + (c + a - ca) - 1 = 2a + b + c - 1 - ba - ca.$$

Therefore the second distributive law holds. (The proof for the first distributive law is similar.)

(b) For all  $a, b \in \mathbf{Z}$ ,

$$a \odot b = a + b - ab = b + a - ba = b \odot a,$$

because both ordinary addition and ordinary multiplication are commutative operations for  $\mathbf{Z}$ . Hence  $(\mathbf{Z}, \oplus, \odot)$  is a commutative ring.

(c) Aside from 0 the only other unit is 2, since  $2 \odot 2 = 2 + 2 - (2 \cdot 2) = 0$ , the unity for  $(\mathbf{Z}, \oplus, \odot)$ .

(d) This ring is an integral domain, but not a field. For all  $a, b \in \mathbf{Z}$  we see that

$$a \odot b = 1 \text{ (the zero element)} \Rightarrow a + b - ab = 1 \Rightarrow a(1 - b) = (1 - b) \Rightarrow (a - 1)(1 - b) = 0 \Rightarrow a = 1 \text{ or } b = 1, \text{ so there are no proper divisors of zero in } (\mathbf{Z}, \oplus, \odot).$$

6. The trouble here is with the Distributive Laws. For  $a, b, c \in \mathbf{Z}$  we find that

$$\begin{aligned} a \odot (b \oplus c) &= a \odot (b + c - 7) = a + (b + c - 7) - 3a(b + c - 7) \\ &= a + b + c - 3ab - 3ac + 21a - 7 \\ &= 22a + b + c - 3ab - 3ac - 7, \end{aligned}$$

while

$$\begin{aligned} (a \odot b) \oplus (a \odot c) &= (a + b - 3ab) \oplus (a + c - 3ac) \\ &= (a + b - 3ab) + (a + c - 3ac) - 7 \\ &= 2a + b + c - 3ab - 3ac - 7. \end{aligned}$$

Hence, if  $a \neq 0$ , then  $a \odot (b \oplus c) \neq (a \odot b) \oplus (a \odot c)$ .

7. From the previous exercise we know that we need to determine the condition(s) on  $k, m$  for which the Distributive Laws will hold. Since  $\odot$  is commutative we can focus on just one of these laws.

If  $x, y, z \in \mathbf{Z}$ , then

$$x \odot (y \oplus z) = (x \odot y) \oplus (x \odot z) \Rightarrow$$

$$x \odot (y + z - k) = (x + y - mxy) \oplus (x + z - mxz)$$

$$\Rightarrow x + (y + z - k) - mx(y + z - k) = (x + y - mxy) + (x + z - mxz) - k$$

$\Rightarrow x + y + z - k - mxy - mxz + mkx = x + y - mxy + x + z - mxz - k$   
 $\Rightarrow mkx = x \Rightarrow mk = 1 \Rightarrow m = k = 1$  or  $m = k = -1$ , since  $m, k \in \mathbf{Z}$ .

8.

- (a)  $x$  (b)  $-s = t, -t = s, -x = x, -y = y$   
 (c)  $t(s + xy) = y$  (d) Yes, the ring is commutative.  
 (e) No, there is no unity. (f) The elements  $s, y$  are a pair of (proper) zero divisors.

9. (a) We shall verify one of the distributive laws. If  $a, b, c \in \mathbf{Q}$ , then

$$\begin{aligned} a \odot (b \oplus c) &= a \odot (b + c + 7) \\ &= a + (b + c + 7) + [a(b + c + 7)]/7 \\ &= a + b + c + 7 + (ab/7) + (ac/7) + a, \end{aligned}$$

while

$$\begin{aligned} (a \odot b) \oplus (a \odot c) &= (a \odot b) + (a \odot c) + 7 \\ &= a + b + (ab/7) + a + c + (ac/7) + 7 \\ &= a + b + c + 7 + (ab/7) + (ac/7) + a. \end{aligned}$$

Also, the rational number  $-7$  is the zero element, and the additive inverse of each rational number  $a$  is  $-14 - a$ .

(b) Since  $a \odot b = a + b + (ab/7) = b + a + (ba/7) = b \odot a$  for all  $a, b \in \mathbf{Q}$ , the ring  $(\mathbf{Q}, \oplus, \odot)$  is commutative.

(c) For each  $a \in \mathbf{Q}$ ,  $a = a \odot u = a + u + (au/7) \Rightarrow u[1 + (a/7)] = 0 \Rightarrow u = 0$ , because  $a$  is arbitrary. Hence the rational number  $0$  is the unity for this ring.

Now let  $a \in \mathbf{Q}$ , where  $a \neq -7$ , the zero element of the ring. Can we find  $b \in \mathbf{Q}$  so that  $a \odot b = 0$  - that is, so that  $a + b + (ab/7) = 0$ ? It follows that  $a + b + (ab/7) = 0 \Rightarrow b(1 + (a/7)) = -a \Rightarrow b = (-a)/[1 + (a/7)]$ . Hence every rational number, other than  $-7$ , is a unit.

(d) From part (c) we know that  $(\mathbf{Q}, \oplus, \odot)$  is a field. In order to verify that it is also an integral domain, let  $a, b \in \mathbf{Q}$  with  $a \odot b = -7$ . Here we have  $a \odot b = -7 \Rightarrow a + b + (ab/7) = -7 \Rightarrow a[1 + (b/7)] = -b - 7 \Rightarrow a[7 + b] = (-1)[7 + b](7) \Rightarrow (a + 7)(b + 7) = 0 \Rightarrow a + 7 = 0$  or  $b + 7 = 0 \Rightarrow a = -7$  or  $b = -7$ .

Consequently, there are no proper divisors of zero (the rational number  $-7$ ) and  $(\mathbf{Q}, \oplus, \odot)$  is an integral domain.

10. (a)  $k = 3; m = -3$ .

(b) The zero element is  $k$ . Hence we have  $6 \oplus (-9) = k = 6 + (-9) - k$ , so  $2k = -3$  and  $k = -3/2$ . [Here  $m = 3/2$ .]

(c) The unity is the rational number  $0$ . So we want  $0 = 2 \odot (1/8) = 2 + (1/8) + [2(1/8)/m]$ . This happens when  $-17/8 = 1/4m$ , or  $4m = -8/17$ . Hence  $m = -2/17$  and  $k = 2/17$ .

11. (a) For example,  $(a+bi)+(c+di) = (a+c)+(b+d)i = (c+a)+(d+b)i = (c+di)+(a+bi)$ , because addition in  $\mathbf{Z}$  is commutative. In like manner, each of the other properties for  $R$  to be a commutative ring with unity follow from the corresponding property of  $(\mathbf{Z}, +, \cdot)$ . Finally, with respect to divisors of zero, if  $(a+bi)(c+di) = (ac-bd)+(bc+ad)i = 0$  and  $a+bi \neq 0$ , then at least one of  $a, b$  is nonzero. Assume, without loss of generality, that  $a \neq 0$ .  $ac-bd = 0 \implies c = bd/a$ ;  $bc+ad = 0 \implies d = -bc/a$ .  $cd = (bd/a)(-bc/a) = (-b^2/a^2)(cd) \implies cd(1 + (b^2/a^2)) = 0 \implies cd(a^2 + b^2) = 0 \implies c = 0$  or  $d = 0$ , since  $a, b, c, d \in \mathbf{Z}$  and  $a \neq 0$ .  $c = 0, d = -bc/a \implies d = 0$ . Also  $d = 0, c = bd/a \implies c = 0$ . Hence  $c+di = 0$  and  $R$  is an integral domain.

(b)  $a+bi$  is a unit in  $R$  if there is an element  $c+di \in R$  with  $(a+bi)(c+di) = 1$ .  $1 = (a+bi)(c+di) = (ac-bd) + (bc+ad)i \implies ac-bd = 1, bc+ad = 0 \implies c = a/(a^2+b^2), d = -b/(a^2+b^2)$ .  $c, d \in \mathbf{Z} \implies a^2+b^2 = 1 \implies a = \pm 1, b = 0; a = 0, b = \pm 1$ . Hence, the units of  $R$  are  $1, -1, i,$  and  $-i$ .

12. (a) 
$$\begin{bmatrix} 1 & 2 \\ 3 & 7 \end{bmatrix} \begin{bmatrix} a & b \\ c & d \end{bmatrix} = \begin{bmatrix} 1 & 0 \\ 0 & 1 \end{bmatrix} \implies a+2c = 1, 3a+7c = 0, b+2d = 0, 3b+7d = 1 \implies a = 7, b = -2, c = -3, d = 1.$$

(b) 
$$\begin{bmatrix} 1 & 2 \\ 3 & 8 \end{bmatrix}^{-1} = \begin{bmatrix} 4 & -1 \\ (-3/2) & (1/2) \end{bmatrix} \in M_2(\mathbf{Q})$$
 but this matrix is not in  $M_2(\mathbf{Z})$ .

13. 
$$\begin{bmatrix} a & b \\ c & d \end{bmatrix}^{-1} = (1/(ad-bc)) \begin{bmatrix} d & -b \\ -c & a \end{bmatrix}, \text{ when } ad-bc \neq 0.$$

14. Let  $\mathcal{U} = \{1, 2, 3\}$  and  $R = \mathcal{P}(\mathcal{U})$ . Then  $(R, \Delta, \cap)$  is a ring with eight elements. To obtain a ring with 16 elements consider  $\mathcal{U} = \{1, 2, 3, 4\}$ . In general, for each  $n \in \mathbf{Z}^+$ , if  $\mathcal{U} = \{1, 2, \dots, n\}$  and  $R = \mathcal{P}(\mathcal{U})$ , then  $(R, \Delta, \cap)$  is a ring with  $|R| = 2^n$ .

15. (a)  $xx = x(t+y) = xt + xy = t + y = x$   
 $yt = (x+t)t = xt + tt = t + t = s$   
 $yy = y(t+x) = yt + yx = s + s = s$   
 $tx = (y+x)x = yx + xx = s + x = x$   
 $ty = (y+x)y = yy + xy = s + y = y$

(b) Since  $tx = x \neq t = xt$ , this ring is not commutative.

(c) There is no unity, and consequently no units.

(d) The ring is neither an integral domain nor a field.

## Section 14.2

1. (Theorem 14.5 (a)) Suppose that  $u_1, u_2 \in R$  and that  $u_1, u_2$  are both unity elements. Then  $u_1 = u_1 u_2 = u_2$ . The first equality holds because  $u_2$  is a unity element; the second equality follows since  $u_1$  is a unity element.

(Theorem 14.5 (b)) Let  $y_1, y_2 \in R$  with  $xy_1 = y_1x = u = xy_2 = y_2x$ , where  $u$  is the unity of  $R$ . Then  $y_1 = uy_1 = (y_2x)y_1 = y_2(xy_1) = y_2u = y_2$ .

(Theorem 14.10 (b)) If  $S$  is a subring of  $R$ , then  $a, b \in S \implies a + b, ab \in S$ . Conversely, let  $S = \{x_1, x_2, \dots, x_n\}$ .  $T = \{x_i + x_1 | 1 \leq i \leq n\} \subseteq S$ .  $x_i + x_1 = x_j + x_1 \implies x_i = x_j$ , so  $|T| = n$  and  $T = S$ . Hence  $x_i + x_1 = x_1$  for some  $1 \leq i \leq n$ , and  $x_i = z$ , the zero element of  $R$ . For each  $x \in S$ ,  $x + S = \{x + x_i | 1 \leq i \leq n\} = S$ . With  $z \in S$ ,  $x + x_j = z$  for some  $x_j \in S$ , so  $x_j = -x \in S$ . Consequently, by Theorem 14.9  $S$  is a subring of  $R$ .

2. (a)  $a(b - c) = a[b + (-c)] = ab + a(-c) = ab + [a(-c)] = ab + (-ac) = ab - (ac)$ .  
 (b) This part is verified in a similar way.
3. (a)  $(ab)(b^{-1}a^{-1}) = aua^{-1} = aa^{-1} = u$  and  $(b^{-1}a^{-1})(ab) = b^{-1}ub = b^{-1}b = u$ , so  $ab$  is a unit. Since the multiplicative inverse of a unit is unique, it follows that  $(ab)^{-1} = b^{-1}a^{-1}$ .

$$(b) \quad A^{-1} = \begin{bmatrix} 2 & -7 \\ -1 & 4 \end{bmatrix}, \quad B^{-1} = \begin{bmatrix} 1 & -2 \\ -2 & 5 \end{bmatrix}, \quad (AB)^{-1} = \begin{bmatrix} 4 & -15 \\ -9 & 34 \end{bmatrix},$$

$$(BA)^{-1} = \begin{bmatrix} 16 & -39 \\ -9 & 22 \end{bmatrix}, \quad B^{-1}A^{-1} = \begin{bmatrix} 4 & -15 \\ -9 & 34 \end{bmatrix}.$$

4. Let  $u$  be the unity of  $R$  and let  $x$  be a unit. Hence there is an element  $y \in R$  with  $xy = yx = u$ . If  $xw = z$ , the zero of  $R$ , then  $y(xw) = yz = z$  and  $y(xw) = (yx)w = uw = w$ . Hence  $x$  is not a zero divisor.

5.  $(-a)^{-1} = -(a^{-1})$

6. (a)  $S = \{s, w\}$

$$\begin{array}{ll} s + s = s & s \cdot s = s \\ s + w = w + s = w & s \cdot w = w \cdot s = s \\ w + w = s & w \cdot w = w \end{array}$$

$$-s = s, -w = w$$

It follows from Theorem 14.9 that  $(S, +, \cdot)$  is a subring of  $(R, +, \cdot)$ .

For all  $r \in R$ ,  $rs = sr = s$  and  $rw = wr = s$  or  $w$ . Hence  $(S, +, \cdot)$  is an ideal of  $(R, +, \cdot)$ .

(b)  $T = \{s, v, x\}$ .

+	s	v	x
s	s	v	x
v	v	x	s
s	x	s	v

·	s	v	x
s	s	s	s
v	s	x	v
x	s	v	x

$$-s = s, -v = x, -x = v.$$

It follows from Theorem 14.9 that  $(T, +, \cdot)$  is a subring of  $(R, +, \cdot)$ .

Also, for all  $r \in R$  we have  $rs, sr, rv, vr, rx,$  and  $xr$  in  $T$ , so  $(T, +, \cdot)$  is an ideal of  $(R, +, \cdot)$ .

7.  $z \in S, T \implies z \in S \cap T \implies S \cap T \neq \emptyset$ .  $a, b \in S \cap T \implies a, b \in S$  and  $a, b \in T \implies a + b, ab \in S$  and  $a + b, ab \in T \implies a + b, ab \in S \cap T$ .  
 $a \in S \cap T \implies a \in S$  and  $a \in T \implies -a \in S$  and  $-a \in T \implies -a \in S \cap T$ .  
 So  $S \cap T$  is a subring of  $R$ .

8. For  $x = y = 0$  we have  $\begin{bmatrix} 0 & 0 \\ 0 & 0 \end{bmatrix} \in S$ , so  $S$  is not empty.

Now consider two elements of  $S$  — that is, two matrices of the form

$$\begin{bmatrix} x & x - y \\ x - y & y \end{bmatrix} \quad \text{and} \quad \begin{bmatrix} v & v - w \\ v - w & w \end{bmatrix},$$

where  $x, y, v, w \in \mathbf{Z}$ . Then

$$(i) \quad \begin{bmatrix} x & x - y \\ x - y & y \end{bmatrix} - \begin{bmatrix} v & v - w \\ v - w & w \end{bmatrix} = \begin{bmatrix} x - v & (x - y) - (v - w) \\ (x - y) - (v - w) & y - w \end{bmatrix} =$$

$$\begin{bmatrix} x - v & (x - v) - (y - w) \\ (x - v) - (y - w) & y - w \end{bmatrix},$$

an element of  $S$ ; and

(ii)

$$\begin{bmatrix} x & x - y \\ x - y & y \end{bmatrix} \begin{bmatrix} v & v - w \\ v - w & w \end{bmatrix} = \begin{bmatrix} xv + (x - y)(v - w) & x(v - w) + (x - y)w \\ (x - y)v + y(v - w) & (x - y)(v - w) + yw \end{bmatrix} =$$

$$\begin{bmatrix} xv + xv - yv - xw + yw & xv - xw + xw - yw \\ xv - yv + yv - yw & xv - yv - xw + yw + yw \end{bmatrix} =$$

$$\begin{bmatrix} xv + xv - yv - xw + yw & xv - yw \\ xv - yw & xv - yv - xw + yw + yw \end{bmatrix} = \begin{bmatrix} a & a - b \\ a - b & b \end{bmatrix}$$

for  $a = xv + xv - yv - xw + yw$  and  $b = xv - yv - xw + yw + yw$  — and this result is also in  $S$ .

Therefore,  $S (\neq \emptyset)$  is closed under subtraction and multiplication, and it follows from Theorem 14.10 that  $S$  is a subring of  $R$ .

9. If not, there exist  $a, b \in S$  with  $a \in T_1, a \notin T_2$ , and  $b \in T_2, b \notin T_1$ . Since  $S$  is a subring of  $R$ , it follows that  $a + b \in S$ . Hence  $a + b \in T_1$  or  $a + b \in T_2$ .

Assume without loss of generality that  $a + b \in T_1$ . Since  $a \in T_1$  we have  $-a \in T_1$ , so by the closure under addition in  $T_1$  we now find that  $(-a) + (a + b) = (-a + a) + b = b \in T_1$ , a contradiction.

Therefore,  $S \subseteq T_1 \cup T_2 \implies S \subseteq T_1$  or  $S \subseteq T_2$ .

10. (a) If  $r$  is a proper divisor of zero we are finished. Otherwise, consider the function  $f: R \rightarrow R$  where  $f(a) = ar$ , for all  $a \in R$ . This function  $f$  is one-to-one — if not, we have  $f(a_1) = f(a_2)$  for distinct elements  $a_1, a_2$  in  $R$ . But  $f(a_1) = f(a_2) \implies a_1r = a_2r \implies (a_1 - a_2)r = z$ , the zero element of  $R$ . And since  $a_1 - a_2 \neq z$  and  $r \neq z$  we find that  $r$  is a proper divisor of zero. Furthermore, with  $R$  finite it follows from Theorem 5.11 that  $f$  is also an onto function. Consequently, there is an element  $s$  in  $R$  such that  $sr = f(s) = u$ , and since  $R$  is commutative we have  $rs = u$ . With  $rs = u = sr$  we find that  $r$  is a unit of  $R$ .
- (b) The result in part (a) is not valid when  $R$  is infinite. Consider the commutative ring  $(\mathbf{Z}, +, \cdot)$  with unity 1. For any integer  $n$ , if  $n \neq -1, 0, 1$ , then  $n$  is neither a proper divisor of zero nor a unit.

11. (a) Follows by Theorem 14.9.

(b)  $\begin{bmatrix} 1 & 0 \\ 0 & 1 \end{bmatrix}$                       (c)  $\begin{bmatrix} 1 & 0 \\ 0 & 0 \end{bmatrix}$

(d)  $S$  is an integral domain while  $R$  is a noncommutative ring with unity.

(e)  $S$  is not an ideal of  $R$  — for example,  $\begin{bmatrix} 1 & 1 \\ 1 & 1 \end{bmatrix} \begin{bmatrix} 1 & 0 \\ 0 & 0 \end{bmatrix} = \begin{bmatrix} 1 & 0 \\ 1 & 0 \end{bmatrix}$ , and this result is not in  $S$ .

12. (a) Let

$$A = \begin{bmatrix} a & 0 \\ b & c \end{bmatrix}, \quad B = \begin{bmatrix} d & 0 \\ e & f \end{bmatrix} \in S. \quad \text{Then } A + B =$$

$$\begin{bmatrix} a+d & 0 \\ b+e & c+f \end{bmatrix}, \quad \text{and } AB = \begin{bmatrix} ad & 0 \\ bd+ce & cf \end{bmatrix} \quad \text{with}$$

$a + d, b + e, c + f, ad, bd + ce, \text{ and } cf \in \mathbf{Z}$ . So  $A + B, AB \in S$ . Also,

$$\begin{bmatrix} -a & 0 \\ -b & -c \end{bmatrix} \in S \quad \text{and} \quad \begin{bmatrix} -a & 0 \\ -b & -c \end{bmatrix} = -A.$$

Hence  $S$  is a subring of  $M_2(\mathbf{Z})$ , by Theorem 14.9.

However,  $S$  is not an ideal of  $M_2(\mathbf{Z})$ . We have

$$\begin{bmatrix} 1 & 0 \\ 1 & 1 \end{bmatrix} \in S \quad \text{and} \quad \begin{bmatrix} 1 & 1 \\ 1 & 1 \end{bmatrix} \in M_2(\mathbf{Z}) \quad \text{but}$$

$$\begin{bmatrix} 1 & 1 \\ 1 & 1 \end{bmatrix} \begin{bmatrix} 1 & 0 \\ 1 & 1 \end{bmatrix} = \begin{bmatrix} 2 & 1 \\ 2 & 1 \end{bmatrix} \notin S.$$

$$(b) \text{ Let } A = \begin{bmatrix} 2a & 2b \\ 2c & 2d \end{bmatrix}, B = \begin{bmatrix} 2e & 2f \\ 2g & 2h \end{bmatrix} \in T.$$

$$\text{Then } A + B = \begin{bmatrix} 2a + 2e & 2b + 2f \\ 2c + 2g & 2d + 2h \end{bmatrix} = \begin{bmatrix} 2(a + e) & 2(b + f) \\ 2(c + g) & 2(d + h) \end{bmatrix}$$

$$\text{and } AB = \begin{bmatrix} 4ae + 4bg & 4af + 4bh \\ 4ce + 4dg & 4cf + 4dh \end{bmatrix} = \begin{bmatrix} 2(2ae + 2bg) & 2(2af + 2bh) \\ 2(2ce + 2dg) & 2(2cf + 2dh) \end{bmatrix}$$

$$\text{so } A + B, AB \in T. \text{ Also } \begin{bmatrix} -2a & -2b \\ -2c & -2d \end{bmatrix} = \begin{bmatrix} 2(-a) & 2(-b) \\ 2(-c) & 2(-d) \end{bmatrix}$$

is the additive inverse of  $A$  and it is in  $T$ . So by Theorem 14.9  $T$  is a subring of  $M_2(\mathbf{Z})$ .

$$\text{If } C = \begin{bmatrix} w & x \\ y & z \end{bmatrix} \in M_2(\mathbf{Z}) \text{ then } CA = \begin{bmatrix} w & x \\ y & z \end{bmatrix} \begin{bmatrix} 2a & 2b \\ 2c & 2d \end{bmatrix} =$$

$$\begin{bmatrix} 2aw + 2cx & 2bw + 2dx \\ 2ay + 2cz & 2by + 2dz \end{bmatrix} = \begin{bmatrix} 2(aw + cx) & 2(bw + dx) \\ 2(ay + cz) & 2(by + dz) \end{bmatrix} \quad \text{and}$$

$$AC = \begin{bmatrix} 2a & 2b \\ 2c & 2d \end{bmatrix} \begin{bmatrix} w & x \\ y & z \end{bmatrix} =$$

$$\begin{bmatrix} 2aw + 2by & 2ax + 2bz \\ 2cw + 2dy & 2cx + 2dz \end{bmatrix} = \begin{bmatrix} 2(aw + by) & 2(ax + bz) \\ 2(cw + dy) & 2(cx + dz) \end{bmatrix}$$

and  $CA, AC \in T$ , so  $T$  is an ideal of  $M_2(\mathbf{Z})$ .

13. Since  $za = z$ , it follows that  $z \in N(a)$  and  $N(a) \neq \emptyset$ . If  $r_1, r_2 \in N(a)$ , then  $(r_1 - r_2)a = r_1a - r_2a = z - z = z$ , so  $r_1 - r_2 \in N(a)$ . Finally, if  $r \in N(a)$  and  $s \in R$ , then  $(rs)a = (sr)a = s(ra) = sz = z$ , so  $rs, sr \in N(a)$ . Hence  $N(a)$  is an ideal - by Definition 14.6.

14. (a)  $I \subseteq R$ . For each  $r \in R$ ,  $ru = r \in I$ , so  $R \subseteq I$ . Hence  $I = R$ .

(b) Let  $x \in I$  with  $x$  a unit of  $R$ . Let  $y \in R$  where  $xy = yx = u$ . Then  $y \in R$ ,  $x \in I \implies yx = u \in I$  and the result follows by part (a).

15. Two ideals:  $R$  and  $\{z\}$ , where  $z$  is the zero of  $R$ .

16. (a) Since  $u^{-1} = u$ ,  $a^{-1} = b$ ,  $b^{-1} = a$ , each nonzero element of  $(R, +, \cdot)$  is a unit, so  $(R, +, \cdot)$  is a field.

(b)  $\{u, z\}$  is a subring. However,  $a \in R$  and  $u \in \{u, z\}$  but  $au = a \notin \{u, z\}$ , so  $\{u, z\}$  is not an ideal.

(c)  $x + by = z \implies x = -by$ , so  $u = y + b(-by) = y - ay = y + ay = (u + a)y = by$  and  $y = ub^{-1} = b^{-1} = a$ . Hence  $x = -by = -ba = -u = u$ .

17. (a)  $a = au \in aR$ , so  $aR \neq \emptyset$ . If  $ar_1, ar_2 \in aR$ , then  $ar_1 - ar_2 = a(r_1 - r_2) \in aR$ . Also, for  $ar_1 \in aR, r \in R, r(ar_1) = (ar_1)r = a(r_1r) \in aR$ . Hence  $aR$  is an ideal of  $R$ .

(b) Let  $a \in R, a \neq z$ . Then  $a = au \in aR$  so  $aR = R$ . Since  $u \in R = aR, u = ar$  for some  $r \in R$ , and  $r = a^{-1}$ . Hence  $R$  is a field.

18. (a) If  $z_S, z_T$  denote the zero elements of  $S, T$ , respectively, then for all  $s \in S, t \in T, (s, t) \oplus (z_S, z_T) = (s + z_S, t + z_T) = (s, t) = (z_S + s, z_T + t) = (z_S, z_T) \oplus (s, t)$ , so  $(z_S, z_T)$  is the zero element for  $R$ . For  $(s, t), (s_1, t_1), (s_2, t_2) \in R, (s, t) \odot [(s_1, t_1) \oplus (s_2, t_2)] = (s, t) \odot (s_1 + s_2, t_1 + t_2) = (s \cdot (s_1 + s_2), t \cdot (t_1 + t_2)) = (s \cdot s_1 + s \cdot s_2, t \cdot t_1 + t \cdot t_2) = (s \cdot s_1, t \cdot t_1) \oplus (s \cdot s_2, t \cdot t_2) = ((s, t) \odot (s_1, t_1)) \oplus ((s, t) \odot (s_2, t_2))$ . Hence this distributive law follows from the corresponding law in each of the rings  $S, T$ . In the same way one finds that the remaining ring properties are also satisfied by  $(R, \oplus, \odot)$ .

(b) For all  $(s_1, t_1), (s_2, t_2) \in R, (s_1, t_1) \odot (s_2, t_2) = (s_1 \cdot s_2, t_1 \cdot t_2) = (s_2 \cdot s_1, t_2 \cdot t_1) = (s_2, t_2) \odot (s_1, t_1)$ .

(c)  $u_R = (u_S, u_T)$

(d) No. Let  $S, T$  both be the field of rational numbers. In  $S \times T$  there is no multiplicative inverse for  $(2, 0)$ . (Also,  $(2, 0)$  and  $(0, 2)$  are proper divisors of zero  $= (0, 0)$ .)

19. (a)  $\binom{4}{2}(49)$       (b)  $7^4$       (c) Yes, the element  $(u, u, u, u)$ .      (d)  $4^4$

20. (a) By the given recursive definition the result is true for all  $m \in \mathbf{Z}^+$  and  $n = 1$ . Assume the result for all  $m \in \mathbf{Z}^+$  and  $n = k (\geq 1)$ . Now consider  $m \in \mathbf{Z}^+$  and  $n = k + 1$ .  $(m+n)a = (m + (k+1))a = ((m+1) + k)a = (m+1)a + ka$  (by the induction hypothesis)  $= (ma+a) + ka$  (by the definition given in the exercise)  $= ma + (ka+a) = ma + [(k+1)a] = ma + na$ . Hence the result is true for all  $m, n \in \mathbf{Z}^+$ . If  $m$  or  $n$  is 0 the result remains true. If  $m, n$  are both negative we have  $m = -m_1, n = -n_1$ , for  $m_1, n_1 \in \mathbf{Z}^+$  and  $(m+n)(a) = (-m_1 - n_1)(a) = (m_1 + n_1)(-a) = m_1(-a) + n_1(-a) = (-m_1)a + (-n_1)a = ma + na$ . Finally, suppose  $mn < 0$ . We consider the case  $m > 0, n = -n_1 < 0$ . Then  $(m+n)a = (m - n_1)(a)$ . If  $m = n_1$  the result follows. If  $m > n_1, m = s + n_1$  and  $(m+n)a = ((s + n_1) - n_1)a = sa = sa + n_1a - n_1a = (s + n_1)a - n_1a = ma + na$ . For  $m < n_1, n_1 = t + m$  and  $(m+n)a = (m - (t+m))a = (-t)a = t(-a) = t(-a) + m(-a) - m(-a) = -m(-a) + (m+t)(-a) = ma + na$ . (The proof is similar for the case where  $m < 0$  and  $n > 0$ .) Consequently, for all  $m, n \in \mathbf{Z}, (m+n)a = ma + na$ .

(c) For  $n = 1, n(a+b) = a + b = na + nb$ . Assume the result for  $n = k (\geq 1)$  and consider  $n = k + 1$ .  $n(a+b) = (k+1)(a+b) = (k(a+b)) + (a+b) = (ka+kb) + (a+b) = (ka+a) + (kb+b) = (k+1)a + (k+1)b = na + nb$ , so the result is true for all  $n \in \mathbf{Z}^+$ . If  $n < 0$ , let  $n = -m$ . Then  $n(a+b) = (-m)(a+b) = m(-(a+b)) = m((-a) + (-b)) = m(-a) + m(-b) = (-m)(a) + (-m)(b) = na + nb$ , so the result is true for all  $n \in \mathbf{Z}$ .

(b),(d), and (e). The proofs for these parts are done in a similar way.

21. (a) For each  $m \in \mathbb{Z}^+$ ,  $(a^m)(a^1) = a^m a = a^{m+1}$  so the result is true for  $n = 1$ . Assume the result for  $m \in \mathbb{Z}^+$  and  $n = k (\geq 1)$ . For  $m \in \mathbb{Z}^+$ ,  $n = k + 1$ ,  $(a^m)(a^n) = (a^m)(a^{k+1}) = (a^m)(a^k a) = (a^m a^k)(a) = (a^{m+k})(a) = a^{(m+k)+1} = a^{m+(k+1)} = a^{m+n}$ . Consequently, by the Principle of Mathematical Induction the result is true for all  $m, n \in \mathbb{Z}^+$ .

In like manner,  $(a^m)^n = a^{mn}$  for all  $m \in \mathbb{Z}^+$  and  $n = 1$ . Assuming the result for  $m \in \mathbb{Z}^+$  and  $n = k (\geq 1)$ , we consider the case for  $m \in \mathbb{Z}^+$  and  $n = k + 1$ . Then  $(a^m)^{(k+1)} = (a^m)^k (a^m) = (a^{mk})(a^m) = a^{mk+m}$  (from the first result)  $= a^{m(k+1)} = a^{mn}$  and the result is true for all  $m, n \in \mathbb{Z}^+$  by the Principle of Mathematical Induction.

(b) If  $R$  has a unity  $u$ , define  $a^0 = u$ , for  $a \in R$ ,  $a \neq z$ . If  $a$  is a unit of  $R$ , define  $a^{-n}$  as  $(a^{-1})^n$ , for  $n \in \mathbb{Z}^+$ .

### Section 14.3

1. (a) (i)  $118 - 62 = 56 = 7(8)$ , so  $118 \equiv 62 \pmod{8}$   
 (ii)  $-237 - (-43) = -194$ , but 8 does not divide  $-194$ , so  $-237$  and  $-43$  are *not* congruent modulo 8.  
 Also,  $-43 \equiv 5 \pmod{8}$  while  $-237 \equiv 3 \pmod{8}$ , so  $-237$  and  $-43$  are *not* congruent modulo 8.  
 (iii)  $230 - (-90) = 320 = 40(8)$ , so  $230 \equiv -90 \pmod{8}$ .  
 Also,  $230 = 28(8) + 6$  and  $-90 = -12(8) + 6$  so  $230 \equiv 6 \equiv -90 \pmod{8}$ .
- b) (i)  $243 - 76 = 167 = 18(9) + 5$  so 243 and 76 are *not* congruent modulo 9.  
 Also,  $243 = 27(9) + 0$  while  $76 = 8(9) + 4$ . Since the remainders for 243 and 76 are different for division by 9, it follows that 243 and 76 are *not* congruent modulo 9.  
 (ii)  $700 - (-137) = 837 = 93(9)$ , so 700 and  $-137$  are congruent modulo 9.  
 (iii)  $056 - (-1199) = 1143 = 127(9)$ , so  $-56$  and  $-1199$  are congruent modulo 9.
2. (a)  $28 - 6 = 22$ , so  $n (> 1)$  is a divisor of 22. With  $22 = 2 \cdot 11$ , there are four divisors of 22 - including 1. Consequently, there are three possible values for  $n$  - namely, 2, 11, and 22.  
 (b)  $68 - 37 = 31$ , a prime. Consequently,  $n = 31$  in this case.  
 (c)  $301 - 233 = 68 = 2^2 \cdot 17$ , so there are five possible values for  $n (> 1)$  - namely, 2, 4, 17, 34, and 68.  
 (d) Since  $49 - 1 = 48 = 2^4 \cdot 3$ , there are nine possible values for  $n (> 1)$  - namely, 2, 4, 8, 16, 3, 6, 12, 24, 48.
3. (a)  $-6, 1, 8, 14$                       (b)  $-9, 2, 13, 24$                       (c)  $-7, 10, 27, 44$
4. Proof: Here we find the following:  $b \equiv c \pmod{n} \Rightarrow b = c + mn$ , for some  $m \in \mathbb{Z} \Rightarrow ab = ac + m(an) \Rightarrow ab \equiv ac \pmod{an}$ .
5. Proof: Since  $a \equiv b \pmod{n}$  we may write  $a = b + kn$  for some  $k \in \mathbb{Z}$ . And  $m|n \Rightarrow n = \ell m$

for some  $\ell \in \mathbf{Z}$ . Consequently,  $a = b + kn = b + (k\ell)m$  and  $a \equiv b \pmod{m}$ .

6. Proof: If  $a \equiv b \pmod{m}$ , then  $a - b = km$ , for some  $k \in \mathbf{Z}$ . Likewise,  $a \equiv b \pmod{n} \Rightarrow a - b = \ell n$ , for some  $\ell \in \mathbf{Z}$ . With  $km = a - b = \ell n$ , it follows that  $n|km$ .

Now  $\gcd(m, n) = 1 \Rightarrow mx + ny = 1$ , for some  $x, y \in \mathbf{Z}$ . Consequently,  $k = kmx + kny$ , and since  $n|kmx$  (because  $n|km$ ) and  $n|kny$ , we have  $n|k$ . Therefore,  $k = nk_1$ , for some  $k_1 \in \mathbf{Z}$ , and  $a - b = km = k_1(mn)$ . Hence,  $a \equiv b \pmod{mn}$ .

Conversely, suppose that  $a \equiv b \pmod{mn}$ . Then  $a - b = tmn$ , for some  $t \in \mathbf{Z}$ . Consequently,  $a - b = (tm)n \Rightarrow a \equiv b \pmod{n}$ , and  $a - b = (tn)m \Rightarrow a \equiv b \pmod{m}$ .

[Note that this result does not require  $\gcd(m, n) = 1$ .]

7. Let  $a = 8, b = 2, m = 6$ , and  $n = 2$ . Then  $\gcd(m, n) = \gcd(6, 2) = 2 > 1$ ,  $a \equiv b \pmod{m}$  and  $a \equiv b \pmod{n}$ . But  $a - b = 8 - 2 = 6 \neq k(12) = k(mn)$ , for some  $k \in \mathbf{Z}$ . Hence  $a \not\equiv b \pmod{mn}$ .
8. Proof: If  $3|n$  then  $n \equiv 0 \pmod{3}$  and  $2n \equiv 0 \pmod{3}$ . Hence  $2n + 1 \equiv 1 \pmod{3}$  and  $2n - 1 \equiv 2 \pmod{3}$ .

If  $3 \nmid n$ , then exactly one of the following occurs:

(a)  $n \equiv 1 \pmod{3} \Rightarrow 2n \equiv 2 \pmod{3}$ , and so  $2n + 1 \equiv 0 \pmod{3}$ , while  $2n - 1 \equiv 2 \pmod{3}$ , so  $3|(2n + 1)$ .

(b)  $n \equiv 2 \pmod{3} \Rightarrow 2n \equiv 1 \pmod{3}$ , and so  $2n - 1 \equiv 0 \pmod{3}$ , while  $2n + 1 \equiv 2 \pmod{3}$ , so  $3|(2n - 1)$ .

9. Proof: For  $n$  odd consider the  $n - 1$  numbers  $1, 2, 3, \dots, n - 3, n - 2, n - 1$  as  $(n - 1)/2$  pairs: 1 and  $(n - 1)$ , 2 and  $(n - 2)$ , 3 and  $(n - 3), \dots, n - (\frac{n-1}{2}) - 1$  and  $n - (\frac{n-1}{2})$ . The sum of each pair is  $n$  which is congruent to 0 modulo  $n$ . Hence  $\sum_{i=1}^{n-1} i \equiv 0 \pmod{n}$ .

When  $n$  is even we consider the  $n - 1$  numbers  $1, 2, 3, \dots, (n/2) - 1, (n/2), (n/2) + 1, \dots, n - 3, n - 2, n - 1$  as  $(n/2) - 1$  pairs — namely, 1 and  $n - 1$ , 2 and  $n - 2$ , 3 and  $n - 3, \dots, (n/2) - 1$  and  $(n/2) + 1$  — and the single number  $(n/2)$ . For each pair the sum is  $n$ , or 0 modulo  $n$ , so  $\sum_{i=1}^{n-1} i \equiv (n/2) \pmod{n}$ .

10. (Theorem 14.11) For each  $a \in \mathbf{Z}$ ,  $a - a = 0 \cdot n$  so  $a \equiv a \pmod{n}$  and the relation is reflexive. If  $a, b \in \mathbf{Z}$ , then  $a \equiv b \pmod{n} \Rightarrow a - b = kn, k \in \mathbf{Z} \Rightarrow b - a = (-k)n, -k \in \mathbf{Z} \Rightarrow b \equiv a \pmod{n}$ , so the relation is symmetric. Finally let  $a, b, c \in \mathbf{Z}$  with  $a \equiv b \pmod{n}$  and  $b \equiv c \pmod{n}$ . Then  $a - b = kn, b - c = mn$ , for some  $k, m \in \mathbf{Z}$  and  $(a - b) + (b - c) = a - c = (k + m)n$ , so  $a \equiv c \pmod{n}$  and the relation is transitive.

(Theorem 14.12) For all  $[a], [b], [c] \in \mathbf{Z}_n$ ,  $([a] + [b]) + [c] = [a + b] + [c] = [(a + b) + c] = [a + (b + c)]$  (since  $a, b, c \in \mathbf{Z}$  and addition in  $\mathbf{Z}$  is associative)  $= [a] + [b + c] = [a] + ([b] + [c])$ . Hence the addition of equivalence classes in  $\mathbf{Z}_n$  is associative. Likewise, all other properties

for  $(\mathbb{Z}_n, +, \cdot)$  to be a commutative ring with unity [1] follow from the corresponding properties of the ring  $(\mathbb{Z}, +, \cdot)$ .

11. (a) For each  $a \in \mathbb{Z}^+$   $\tau(a) = \tau(a)$ , so the relation is reflexive. If  $a, b \in \mathbb{Z}^+$ ,  $\tau(a) = \tau(b) \implies \tau(b) = \tau(a)$  so the relation is symmetric. Finally, for  $a, b, c \in \mathbb{Z}^+$ ,  $\tau(a) = \tau(b)$  and  $\tau(b) = \tau(c) \implies \tau(a) = \tau(c)$  so the relation is transitive.

(b) No,  $2\mathcal{R}3$ ,  $3\mathcal{R}5$  but  $5\not\mathcal{R}8$ . Also,  $2\mathcal{R}3$ ,  $2\mathcal{R}5$  but  $4\not\mathcal{R}15$ .

12.  $\mathbb{Z}_{11}$ :  $[1]^{-1} = [1]$ ,  $[2]^{-1} = [6]$ ,  $[3]^{-1} = [4]$ ,  $[4]^{-1} = [3]$ ,  $[5]^{-1} = [9]$ ,  $[6]^{-1} = [2]$ ,  $[7]^{-1} = [8]$ ,  $[8]^{-1} = [7]$ ,  $[9]^{-1} = [5]$ ,  $[10]^{-1} = [10]$ .

$\mathbb{Z}_{13}$ :  $[1]^{-1} = [1]$ ,  $[2]^{-1} = [7]$ ,  $[3]^{-1} = [9]$ ,  $[4]^{-1} = [10]$ ,  $[5]^{-1} = [8]$ ,  $[6]^{-1} = [11]$ ,  $[7]^{-1} = [2]$ ,  $[8]^{-1} = [5]$ ,  $[9]^{-1} = [3]$ ,  $[10]^{-1} = [4]$ ,  $[11]^{-1} = [6]$ ,  $[12]^{-1} = [12]$ .

$\mathbb{Z}_{17}$ :  $[1]^{-1} = [1]$ ,  $[2]^{-1} = [9]$ ,  $[3]^{-1} = [6]$ ,  $[4]^{-1} = [13]$ ,  $[5]^{-1} = [7]$ ,  $[6]^{-1} = [3]$ ,  $[7]^{-1} = [5]$ ,  $[8]^{-1} = [15]$ ,  $[9]^{-1} = [2]$ ,  $[10]^{-1} = [12]$ ,  $[11]^{-1} = [14]$ ,  $[12]^{-1} = [10]$ ,  $[13]^{-1} = [4]$ ,  $[14]^{-1} = [11]$ ,  $[15]^{-1} = [8]$ ,  $[16]^{-1} = [16]$ .

13. (a)

$$1009 = 59(17) + 6 \quad 0 < 6 < 17$$

$$17 = 2(6) + 5 \quad 0 < 5 < 6$$

$$6 = 1(5) + 1 \quad 0 < 1 < 5,$$

so  $1 = 6 - 5 = 6 - [17 - 2(6)] = 3(6) - 17 = 3[1009 - 59(17)] - 17 = 3(1009) - 178(17)$ .

Hence  $1 \equiv (-178)(17) \pmod{1009}$ , so  $[17]^{-1} = [-178] = [-178 + 1009] = [831]$ .

(b)  $[100]^{-1} = [111]$                       (c)  $[777]^{-1} = [735]$ .

14. (a)  $\mathbb{Z}_{12}$ :  $\{0\}$ ,  $\{0, 6\}$ ,  $\{0, 4, 8\}$ ,  $\{0, 3, 6, 9\}$ ,  $\{0, 2, 4, 6, 8, 10, 12\}$ ,  $\mathbb{Z}_{12}$ .

$\mathbb{Z}_{18}$ :  $\{0\}$ ,  $\{0, 9\}$ ,  $\{0, 6, 12\}$ ,  $\{0, 3, 6, 9, 12, 15\}$ ,  $\{0, 2, 4, 6, \dots, 16\}$ ,  $\mathbb{Z}_{18}$ .

$\mathbb{Z}_{24}$ :  $\{0\}$ ,  $\{0, 12\}$ ,  $\{0, 8, 16\}$ ,  $\{0, 6, 12, 18\}$ ,  $\{0, 4, 8, 12, 16, 20\}$ ,  $\{0, 3, 6, \dots, 18, 21\}$ ,  $\{0, 2, 4, 6, \dots, 20, 22\}$ ,  $\mathbb{Z}_{24}$ .

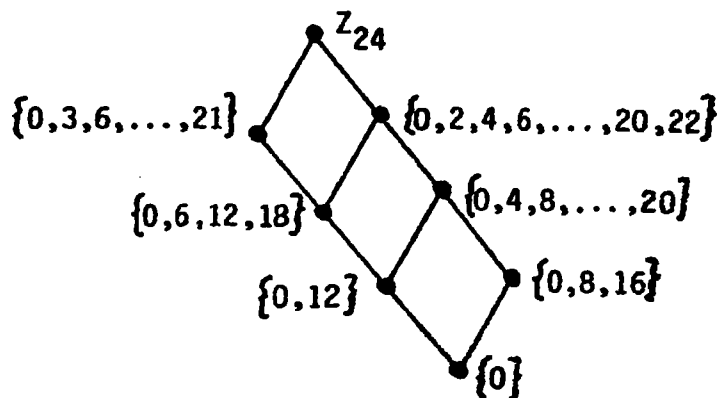
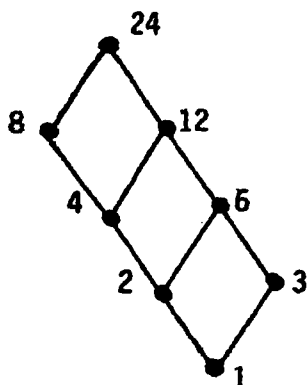
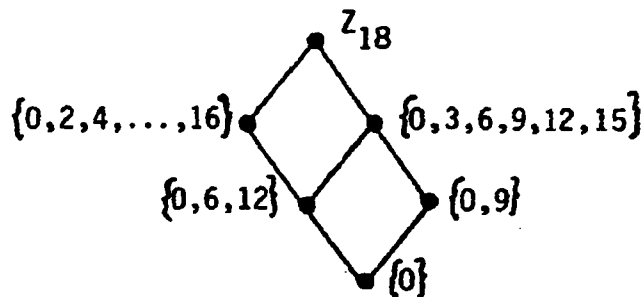
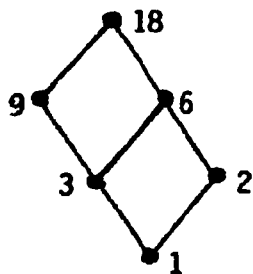
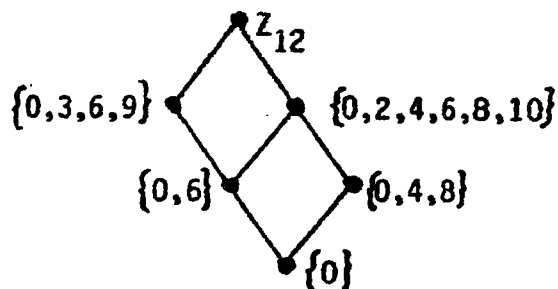
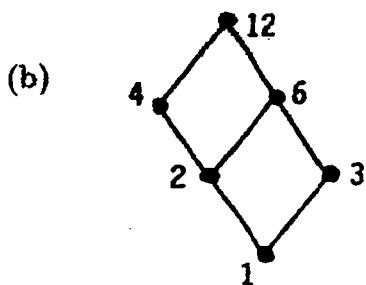

(c) The number of subrings of  $Z_n$  is  $\tau(n)$ , the number of positive divisors of  $n$ .

15. (a) 16 units; 0 proper zero divisors      (b) 72 units; 44 proper zero divisors  
 (c) 1116 units; 0 proper zero divisors.
16. Let  $a_1, a_2, \dots, a_n$  be a list of  $n$  consecutive integers,  $n \geq 1$ . For  $1 \leq i \leq n$ , let  $b_i$  be the remainder upon division of  $a_i$  by  $n$ ;  $b_i \equiv a_i \pmod{n}$ ,  $0 \leq b_i \leq n-1$ . Then  $\{b_1, b_2, \dots, b_n\} = \{0, 1, 2, \dots, n-1\}$ , so  $b_i = 0$  for some  $1 \leq i \leq n$ .  $b_i = 0 \iff a_i \equiv 0 \pmod{n} \iff n|a_i$ .
17.  $\{1, 2, 3, \dots, 1000\} = \{1, 4, 7, 10, \dots, 997, 1000\} \cup \{2, 5, 8, \dots, 995, 998\} \cup \{3, 6, 9, \dots, 999\}$ . In this partition the first cell has 334 elements while the other two cells contain 333 elements each. If three elements are selected from the same cell then their sum will be divisible by three. If one number is selected from each of the three cells then their sum is divisible by three. Consequently the probability that the sum of three elements selected from  $\{1, 2, 3, \dots, 999\}$  is divisible by three is  $[\binom{334}{3} + 2\binom{333}{3} + \binom{334}{1}\binom{333}{1}^2] / \binom{1000}{3}$ .
18. (a) For  $m = 1$  the result is true. Assume the result true for  $m = k$ , i.e.,

$c \equiv d \pmod{n} \implies c^k \equiv d^k \pmod{n}$ , and consider the case of  $m = k+1$ .  $c^m = c^{k+1} = (c^k)(c) \equiv (d^k)(d) \pmod{n}$ , since  $c \equiv d \pmod{n}$  and  $(c^k) \equiv (d^k) \pmod{n}$ . Hence  $c^m = c^{k+1} \equiv d^{k+1} = d^m \pmod{n}$ . By the Principle of Mathematical Induction the result follows for all  $m \in \mathbf{Z}^+$ .

The other result also follows by induction.

(b) Since  $10 \equiv 1 \pmod{9}$ ,  $10^k \equiv 1^k = 1 \pmod{9}$  for all  $k \geq 0$ , and for all  $0 \leq a \leq 9$ ,  $(a)(10^k) \equiv a \pmod{9}$ . Consequently,  $x_n \cdot 10^n + x_{n-1} \cdot 10^{n-1} + \cdots + x_1 \cdot 10 + x_0 \equiv x_n + x_{n-1} + \cdots + x_1 + x_0 \pmod{9}$ .

19. (a) For  $n = 0$  we have  $10^0 = 1 = 1(-1)^0$  so  $10^0 \equiv (-1)^0 \pmod{11}$ . [Since  $10 - (-1) = 11$ ,  $10 \equiv (-1) \pmod{11}$ , or  $10^1 \equiv (-1)^1 \pmod{11}$ . Hence the result is true for  $n = 0, 1$ .] Assume the result true for  $n = k \geq 1$  and consider the case for  $k + 1$ . Then since  $10^k \equiv (-1)^k \pmod{11}$  and  $10 \equiv (-1) \pmod{11}$ , we have  $10^{k+1} = 10^k \cdot 10 \equiv (-1)^k(-1) = (-1)^{k+1} \pmod{11}$ . The result now follows for all  $n \in \mathbf{N}$  by the Principle of Mathematical Induction.

(b) If  $x_n x_{n-1} \dots x_2 x_1 x_0 = x_n \cdot 10^n + x_{n-1} \cdot 10^{n-1} + \cdots + x_2 \cdot 10^2 + x_1 \cdot 10 + x_0$  denotes an  $(n+1)$ -st digit integer, then

$$x_n x_{n-1} \dots x_2 x_1 x_0 \equiv (-1)^n x_n + (-1)^{n-1} x_{n-1} + \cdots + x_2 - x_1 + x_0 \pmod{11}.$$

Proof:  $x_n x_{n-1} \dots x_2 x_1 x_0 = x_n \cdot 10^n + x_{n-1} \cdot 10^{n-1} + \cdots + x_2 \cdot 10^2 + x_1 \cdot 10 + x_0 \equiv x_n(-1)^n + x_{n-1}(-1)^{n-1} + \cdots + x_2(-1)^2 + x_1(-1) + x_0 = (-1)^n x_n + (-1)^{n-1} x_{n-1} + \cdots + x_2 - x_1 + x_0 \pmod{11}$ .

20. If  $a^2 = a$  in  $\mathbf{Z}_p$ , then  $a^2 \equiv a \pmod{p}$ , and it follows that  $p|(a^2 - a)$ . But  $p|(a^2 - a) \implies p|a(a - 1) \implies p|a$  or  $p|(a - 1)$ , because  $p$  is prime. With  $0 \leq a < p$ ,  $p|a \implies a = 0$  and  $p|(a - 1) \implies a = 1$ . So the only elements in  $\mathbf{Z}_p$  that satisfy  $a^2 = a$  are  $a = 0, 1$ . [Or  $a = 0, 1$  are the only idempotent elements under multiplication in  $\mathbf{Z}_p$ .]

21. Let  $g = \gcd(a, n)$ ,  $h = \gcd(b, n)$ .  $a \equiv b \pmod{n} \implies a = b + kn$ , for some  $k \in \mathbf{Z} \implies g|b, h|a$ .  $g|b, g|n \implies g|h$ ;  $h|a, h|n \implies h|g$ . Since  $g, h > 0$ ,  $g = h$ .

22. (a)  $1 = 1$ ;  $2^6 = 64 = 7(9) + 1$ ;  $3^6 = 729 = 7(104) + 1$ ;  $4^6 = 4096 = 7(585) + 1$ ;  $5^6 = 15625 = 7(2232) + 1$ ;  $6^6 = 46656 = 7(6665) + 1$ .

(b) If  $\gcd(n, 7) = 1$ , then  $n \equiv i \pmod{7}$ , for  $1 \leq i \leq 6$  and  $n^6 \equiv i^6 \equiv 1 \pmod{7}$ .  $n^6 \equiv 1 \pmod{7} \iff 7|(n^6 - 1)$ .

23.

(1) Plaintext	<i>a</i>	<i>l</i>	<i>l</i>	<i>g</i>	<i>a</i>	<i>u</i>	<i>l</i>	<i>i</i>	<i>s</i>	<i>d</i>	<i>i</i>	<i>v</i>	<i>i</i>	<i>d</i>	<i>e</i>	<i>d</i>
(2)	0	11	11	6	0	20	11	8	18	3	8	21	8	3	4	3
(3)	3	14	14	9	3	23	14	11	21	6	11	24	11	6	7	6
(4) Ciphertext	<i>D</i>	<i>O</i>	<i>O</i>	<i>J</i>	<i>D</i>	<i>X</i>	<i>O</i>	<i>L</i>	<i>V</i>	<i>G</i>	<i>L</i>	<i>Y</i>	<i>L</i>	<i>G</i>	<i>H</i>	<i>G</i>

<i>i</i>	<i>n</i>	<i>t</i>	<i>o</i>	<i>t</i>	<i>h</i>	<i>r</i>	<i>e</i>	<i>e</i>	<i>p</i>	<i>a</i>	<i>r</i>	<i>t</i>	<i>s</i>
8	13	19	14	19	7	17	4	4	15	0	17	19	18
11	16	22	17	22	10	20	7	7	18	3	20	22	21
<i>L</i>	<i>Q</i>	<i>W</i>	<i>R</i>	<i>W</i>	<i>K</i>	<i>U</i>	<i>H</i>	<i>H</i>	<i>S</i>	<i>D</i>	<i>U</i>	<i>W</i>	<i>V</i>

For each  $\theta$  in row (2), the corresponding result below it in row (3) is  $\theta + 3 \pmod{26}$ .

24. Since the most frequently occurring letter in the English alphabet is *e*, we correspond the plaintext letter *e* with the ciphertext letter *Q*. As *Q* is 12 letters after *e* in the alphabet we have (a)  $\kappa = 12$ ; (b)  $E(\theta) \equiv \theta + 12 \pmod{26}$  and  $D(\theta) \equiv \theta - 12 \pmod{26}$ .

For part (c) consider the following:

(1) Ciphertext	<i>F</i>	<i>T</i>	<i>Q</i>	<i>I</i>	<i>M</i>	<i>K</i>	<i>I</i>	<i>Q</i>	<i>I</i>	<i>Q</i>	<i>D</i>	<i>Q</i>
(2)	5	19	16	8	12	10	8	16	8	16	3	16
(3)	19	7	4	22	0	24	22	4	22	4	17	4
(4) Plaintext	<i>t</i>	<i>h</i>	<i>e</i>	<i>w</i>	<i>a</i>	<i>y</i>	<i>w</i>	<i>e</i>	<i>w</i>	<i>e</i>	<i>r</i>	<i>e</i>

Here the results in row (3) are obtained from those in row (2) by applying the decryption function *D*.

The plaintext reveals the original message as 'The Way We Were'. [This is the title of an Academy award winning song sung by Barbra Streisand, as well as the title of a film starring Barbra Streisand and Robert Redford.]

25. From part (c) of Example 14.15 we know that for an alphabet of  $n$  letters there are  $n \cdot \phi(n)$  affine ciphers. Here we have:

- (a)  $24\phi(24) = (24)[24(1 - \frac{1}{2})(1 - \frac{1}{3})] = (24)(8) = 192$   
 (b)  $25\phi(25) = (25)[25(1 - \frac{1}{5})] = (25)(20) = 500$   
 (c)  $27\phi(27) = (27)[27(1 - \frac{1}{3})] = (27)(18) = 486$   
 (d)  $30\phi(30) = (30)[30(1 - \frac{1}{2})(1 - \frac{1}{3})(1 - \frac{1}{5})] = (30)(8) = 240.$

26. The nonnegative integers that correspond with the given plaintext and ciphertext letters are as follows:

$e : 4$              $W : 22$              $t : 19$              $X : 23$

The encryption function  $E : \mathbb{Z}_{26} \rightarrow \mathbb{Z}_{26}$  is given by  $E(\theta) \equiv \alpha\theta + \kappa \pmod{26}$ , with  $E(4) \equiv 4\alpha + \kappa \equiv 22 \pmod{26}$  and  $E(19) \equiv 19\alpha + \kappa \equiv 23 \pmod{26}$ . Therefore  $(19\alpha + \kappa) - (4\alpha + \kappa) \equiv 15\alpha \equiv 23 - 22 \equiv 1 \pmod{26}$ , and  $\alpha \equiv 15^{-1} \pmod{26}$ . The multiplicative inverse of 15 in  $\mathbb{Z}_{26}$  is 7 since  $15 \cdot 7 = 105 = 1 + 104 = 1 + 4(26) \equiv 1 \pmod{26}$ , so  $\alpha \equiv 7 \pmod{26}$  and  $\kappa \equiv 22 - 4(7) \equiv -6 \equiv 20 \pmod{26}$ . Consequently,  $E(\theta) \equiv 7\theta + 20 \pmod{26}$ .

Here  $D(\theta) \equiv 7^{-1}(\theta - 20) \pmod{26}$ . From above we see that  $7^{-1} \equiv 15 \pmod{26}$ , so  $D(\theta) \equiv 15(\theta - 20) \pmod{26}$ . Applying *D* to the nonnegative integers in row (2) of the following gives us the result in row (3), from which we extract the plaintext.

(1) Ciphertext	R	W	J	W	Q	T	O	O	M	Y	H	K	U	X	G	O
(2)	17	22	9	22	16	19	14	14	12	24	7	10	20	23	6	14
(3)	7	4	17	4	18	11	14	14	10	8	13	6	0	19	24	14
(4) Plaintext	h	e	r	e	s	l	o	o	k	i	n	g	a	t	y	o

E M Y P  
 4 12 24 15  
 20 10 8 3  
 u k i d

So the original message is

'Here's looking at you, kid.' [Spoken by Humphrey Bogart to Ingrid Bergman in the Academy award winning film *Casablanca*.]

27. (a)  $x_0 = 10$

$$x_1 \equiv 5(x_0) + 3 \pmod{19} \equiv \pmod{19} \equiv 15 \pmod{19}, \text{ so } x_1 = 15.$$

$$x_2 \equiv 5(x_1) + 3 \pmod{19} \equiv 78 \pmod{19} \equiv 2 \pmod{19}, \text{ so } x_2 = 2.$$

$$x_3 \equiv 5(x_2) + 3 \pmod{19} \equiv 13 \pmod{19}, \text{ so } x_3 = 13.$$

$$x_4 \equiv 5(x_3) + 3 \pmod{19} \equiv 68 \pmod{19} \equiv 11 \pmod{19}, \text{ so } x_4 = 11.$$

Further computation tells us that  $x_5 = 1$ ,  $x_6 = 8$ ,  $x_7 = 5$ ,  $x_8 = 9$ , and  $x_9 = 10$ , the seed.

So this linearcongruential generator produces nine distinct terms.

(b) 10, 15, 2, 13, 11, 1, 9, 5, 9, 10, 15, 2, ...

28.  $x_0 = 1$

$$x_1 = 28$$

$$x_2 \equiv x_1 + x_0 \pmod{37} \equiv 28 + 1 \pmod{37} \equiv 29 \pmod{37}, \text{ so } x_2 = 29$$

$$x_3 \equiv x_2 + x_1 \pmod{37} \equiv 29 + 28 \pmod{37} \equiv 57 \pmod{37}, \text{ so } x_3 = 20$$

Further computation leads to  $x_4 = 12$ ,  $x_5 = 32$ ,  $x_6 = 7$ ,  $x_7 = 2$ ,  $x_8 = 9$ , and  $x_9 = 11$ .

29. Proof: (By Mathematical Induction)

[Note that for  $n \geq 1$ ,  $(a^n - 1)/(a - 1) = a^{n-1} + a^{n-2} + \dots + 1$ , which can be computed in the ring  $(\mathbf{Z}, +, \cdot)$ .]

When  $n = 0$ ,  $a^0 x_0 + c[(a^0 - 1)/(a - 1)] \equiv x_0 + c[0/(a - 1)] \equiv x_0 \pmod{m}$ , so the formula is true in this first basis ( $n = 0$ ) case. Assuming the result for  $n$  we have

$x_n \equiv a^n x_0 + c[(a^n - 1)/(a - 1)] \pmod{m}$ ,  $0 \leq x_n < m$ . Continuing to the next case we learn that

$$\begin{aligned}
 x_{n+1} &\equiv ax_n + c \pmod{m} \\
 &\equiv a[a^n x_0 + c[(a^n - 1)/(a - 1)]] + c \pmod{m} \\
 &\equiv a^{n+1} x_0 + ac[(a^n - 1)/(a - 1)] + c(a - 1)/(a - 1) \pmod{m} \\
 &\equiv a^{n+1} x_0 + c[(a^{n+1} - 1)/(a - 1)] \pmod{m} \\
 &\equiv a^{n+1} x_0 + c[(a^{n+1} - 1)/(a - 1)] \pmod{m}
 \end{aligned}$$

and we select  $x_{n+1}$  so that  $0 \leq x_{n+1} < m$ . It now follows by the Principle of Mathematical Induction that

$$x_n \equiv a^n x_0 + c[(a^n - 1)/(a - 1)] \pmod{m}, \quad 0 \leq x_n < m.$$

30. From the previous exercise we have

$$\begin{aligned}x_4 &\equiv a^4 x_0 + c[(a^4 - 1)/(a - 1)] \pmod{m} \\ &\equiv a^4 x_0 + c(a^3 + a^2 + a + 1) \pmod{m} \\ &\equiv 7^4 x_0 + 4(7^3 + 7^2 + 7 + 1) \pmod{9} \\ &\equiv 7x_0 + 4(1 + 4 + 7 + 1) \pmod{9} \\ &\equiv 7x_0 + 4(13) \pmod{9} \\ &\equiv 7x_0 + 4(4) \pmod{9} \equiv 7x_0 + 7 \pmod{9}\end{aligned}$$

With  $x_4 = 1$ , it follows from  $1 \equiv 7x_0 + 7 \pmod{9}$  that  $3 \equiv 7x_0 \pmod{9}$ . Since  $7^{-1} \equiv 4 \pmod{9}$ , we have  $12 \equiv \pmod{9}$ , so  $x_0 = 3$ , the seed.

31. Proof: Let  $n, n+1$ , and  $n+2$  be three consecutive integers. Then  $n^3 + (n+1)^3 + (n+2)^3 = n^3 + (n^3 + 3n^2 + 3n + 1) + (n^3 + 6n^2 + 12n + 8) = (3n^3 + 15n) + 9(n^2 + 1)$ . So we consider  $3n^3 + 15n = 3n(n^2 + 5)$ . If  $3|n$ , then we are finished. If not, then  $n \equiv 1 \pmod{3}$  or  $n \equiv 2 \pmod{3}$ . If  $n \equiv 1 \pmod{3}$ , then  $n^2 + 5 \equiv 1 + 5 \equiv 0 \pmod{3}$ , so  $3|(n^2 + 5)$ . If  $n \equiv 2 \pmod{3}$ , then  $n^2 + 5 \equiv 9 \equiv 0 \pmod{3}$ , and  $3|(n^2 + 5)$ . All cases are now covered, so we have  $3|[n(n^2 + 5)]$ . Hence  $9|[3n(n^2 + 5)]$  and, consequently, 9 divides  $(3n^3 + 15n) + 9(n^2 + 1) = n^3 + (n+1)^3 + (n+2)^3$ .

32. Since  $55 = 32 + 16 + 4 + 2 + 1 = (110111)2$ , we have  $3^{55} = 3^{32} \cdot 3^{16} \cdot 3^4 \cdot 3^2 \cdot 3^1$ .

Now,  $3^1 \equiv 3 \pmod{10}$  and  $3^2 \equiv 9 \pmod{10}$ , so  $3^2 \cdot 3^1 \equiv 7 \pmod{10}$ . Further,  $3^4 \equiv 81 \equiv 1 \pmod{10}$  so  $3^4 \cdot 3^2 \cdot 3^1 \equiv 7 \pmod{10}$ . With  $3^4 \equiv 1 \pmod{10}$  it follows that  $3^8 \equiv 1 \pmod{10}$ ,  $3^{16} \equiv 1 \pmod{10}$  and  $3^{32} \equiv 1 \pmod{10}$ . Consequently,

$$3^{55} = 3^{32} \cdot 3^{16} \cdot 3^4 \cdot 3^2 \cdot 3^1 \equiv 1 \cdot 1 \cdot 7 \equiv 7 \pmod{10},$$

so the last digit (that is, the units digit) in  $3^{55}$  is 7.

33. From the presentation given in Example 14.18 it follows that for  $n \in \mathbf{Z}^+$ ,

$$\sum_{k=0}^{n-1} p(k(n+1), n, n) = \frac{1}{n+1} \binom{2n}{n}, \text{ the } n\text{th Catalan number.}$$

$$\begin{aligned}(n-k+1)^2 &\equiv (-k+1)^2 \pmod{n} \\ &\equiv k^2 - 2k + 1 \pmod{n}\end{aligned}$$

$$\begin{aligned}34. &\equiv k - 2k + 1 \pmod{n} - \text{because } k \text{ is idempotent} \\ &\equiv -k + 1 \pmod{n} \\ &\equiv n - k + 1 \pmod{n}\end{aligned}$$

Consequently,  $n - k + 1$  is idempotent in  $\mathbf{Z}_n$  whenever  $k$  is idempotent in  $\mathbf{Z}_n$ .

35. (a)  $1 + 2 + 3 = 6 \equiv 1 \pmod{5}$ ;  $0 + 4 = 4 \equiv 1 \pmod{3}$ ;  $2 + 2 + 7 + 5 = 16 \equiv 2 \pmod{7}$ .  $h(123 - 04 - 2275) = 112$ .

(b) Let  $n = 112 - 43 - 8295$ . Then  $h(112 - 43 - 8295) = 413$ .

36.

```
Program Hashing (input,output);
Var
    ssnun: array[1..9] of integer;
    i, a, b, c, result: integer;
Begin
    Writeln ('Input the social security number, ',
            'without hypbens, one digit at a time. ');

    Writeln ('Input the 1st digit and then type a return. ');
    Read (ssnun[1]);
    Writeln ('The 1st digit is ', ssnun[1]:0);

    Writeln ('Input the 2nd digit and then type a return. ');
    Read (ssnun[2]);
    Writeln ('The 2nd digit is ', ssnun[2]:0);

    Writeln ('Input the 3rd digit and then type a return. ');
    Read (ssnun[3]);
    Writeln ('The 3rd digit is ', ssnun[3]:0);

    For i := 4 to 9 do
        Begin
            Writeln ('Input the ', i:0, '-th digit and then type a return. ');
            Read (ssnun[i]);
            Writeln ('The ', i:0, '-th digit is ', ssnun[i]:0)
        End;

    a := (ssnun[1] + ssnun[2] + ssnun[3]) Mod 5;
    b := (ssnun[4] + ssnun[5]) Mod 3;
    c := (ssnun[6] + ssnun[7] + ssnun[8] + ssnun[9]) Mod 7;
    result := 100*a + 10*b + c;

    Writeln ('The hashing function assigns the result ',
            result:0, ' to this social security number.')
```

End.

37. (a)  $h(206) = 1 \pmod{41}$ , since  $206 = 5(41) + 1$ . Likewise,  $h(807) = 28 \pmod{41}$ ,  $h(137) = 14 \pmod{41}$ ,  $h(444) = 34 \pmod{41}$ ,  $h(617) = 2 \pmod{41}$ . Since  $h(330) = 2 \pmod{41}$  but that parking space has been assigned, this patron is assigned to the next available space – here, it is 3. Likewise, the last two patrons are assigned to the spaces numbered  $14 + 1 = 15$  and  $3 + 1 = 4$ .
- (b) 1, 2, 3, 4, or 5.

38. (a)  $3x \equiv 7 \pmod{31}$

Since  $\gcd(3, 31) = 1$ ,  $3^{-1}$  exists in  $\mathbf{Z}_{31}$ . Using the Euclidean algorithm we have  $31 = 10(3) + 1$ , so  $1 = 31 - 10(3)$  and  $3^{-1} = [3]^{-1} = [-10] = [21]$ . (Note:  $3 \cdot 21 = 63 = 2(31) + 1$ ). Hence  $3x \equiv 7 \pmod{31} \Rightarrow 21(3x) \equiv 21(7) \pmod{31} \Rightarrow x \equiv 147 \pmod{31} \Rightarrow x \equiv 23 \pmod{31}$ .

(b)  $5x \equiv 8 \pmod{37}$

With  $\gcd(5, 37) = 1$ , we use the Euclidean algorithm to determine  $5^{-1}$  in  $\mathbf{Z}_{37}$ .

$$37 = 7(5) + 2, \quad 0 < 2 < 5$$

$$5 = 2(2) + 1, \quad 0 < 1 < 2$$

So  $1 = 5 - 2(2) = 5 - 2[37 - 7(5)] = 5 - 2(37) + 14(15) = 37(-2) + 5(15)$ . Consequently,  $[1] = [5][15]$  in  $\mathbf{Z}_{37}$  and  $5^{-1} = [5]^{-1} = [15]$ .

Therefore,  $5x \equiv 8 \pmod{37} \Rightarrow 15(5x) \equiv 15(8) \pmod{37} \Rightarrow x \equiv 120 \pmod{37} \Rightarrow x \equiv 9 \pmod{37}$ .

(c)  $6x \equiv 97 \pmod{125}$

Since  $6 \equiv 2 \cdot 3$  and  $125 = 5^3$ , it follows that  $\gcd(6, 125) = 1$ . Using the Euclidean algorithm we learn that

$$125 = 20(6) + 5, \quad 0 < 5 < 6$$

$$6 = 1(5) + 1, \quad 0 < 1 < 5$$

Consequently,  $1 = 6 - 5 = 6 - [125 - 20(6)] = 6 - 125 + 20(6) = 21(6) + 125(-1) = 6(21) + 125(-1)$  and  $[1] = [6][21]$  in  $\mathbf{Z}_{125}$ . So  $6^{-1} = [6]^{-1} = [21]$  and  $6x \equiv 97 \pmod{125} \Rightarrow x \equiv 21 \cdot 97 \pmod{125} \Rightarrow x \equiv 2037 \pmod{125} \Rightarrow x \equiv 37 \pmod{125}$ .

## Section 14.4

1.  $s \rightarrow 0, t \rightarrow 1, v \rightarrow 2, w \rightarrow 3, x \rightarrow 4, y \rightarrow 5$

2. (Theorem 14.15 (d)) The result is true for  $n = 1$ . Assume the result for  $n = k$  and consider  $n = k + 1$ . Then  $f(a^{k+1}) = f(a^k a) = f(a^k)f(a) = [f(a)]^k f(a) = [f(a)]^{k+1}$ . Hence the result follows for all  $n \in \mathbf{Z}^+$  by the Principle of Mathematical Induction.

(Theorem 14.16 (a)) For  $s \in S$ , there exists  $r \in R$  with  $f(r) = s$ , since  $f$  is onto.  $r = u_R r = r u_R$ , so  $s = f(r) = f(u_R r) = f(u_R)f(r) = f(u_r)s$  and  $s = f(r) = f(r u_R) = f(r)f(u_R) = s f(u_R)$ , so  $f(u_R)$  is the unity of  $S$ .

(Theorem 14.16 (b)) Since  $a$  is a unit of  $R$ , there is an element  $b \in R$  with  $ab = ba = u_R$ . Then  $u_S = f(u_R)$  (by part(a))  $= f(ab) = f(a)f(b) = f(ba) = f(b)f(a)$ , so  $f(a)$  is a unit of  $S$ . Since  $b = a^{-1}$ , it follows that  $f(b) = f(a^{-1})$  is a multiplicative inverse of  $f(a)$ . By Theorem 14.5 (b) we have  $f(a^{-1}) = [f(a)]^{-1}$ .

(Theorem 14.16 (c)) Let  $s_1, s_2 \in S$ . Then there exist  $r_1, r_2 \in R$  with  $f(r_i) = s_i, 1 \leq i \leq 2$ . So  $s_1 s_2 = f(r_1)f(r_2) = f(r_1 r_2) = f(r_2 r_1) = f(r_2)f(r_1) = s_2 s_1$ , and consequently  $S$  is commutative.

3. Let  $(R, +, \cdot), (S, \oplus, \odot), (T, +', \cdot')$  be the rings. For all  $a, b \in R$ ,  $(g \circ f)(a+b) = g(f(a+b)) = g(f(a) + f(b)) = g(f(a)) +' g(f(b)) = (g \circ f)(a) +' (g \circ f)(b)$ . Also,  $(g \circ f)(a \cdot b) = g(f(a \cdot b)) = g(f(a) \odot f(b)) = g(f(a)) \cdot' g(f(b)) = (g \circ f)(a) \cdot' (g \circ f)(b)$ . Hence,  $g \circ f$  is a ring homomorphism.

4. Define  $f: \mathbf{R} \rightarrow S$  by  $f(r) = \begin{bmatrix} r & 0 \\ 0 & r \end{bmatrix}$ , for each  $r \in \mathbf{R}$ . Then  $f$  is a one-to-one function from  $\mathbf{R}$  onto  $S$ . For all  $r, s \in \mathbf{R}$ ,

$$f(r+s) = \begin{bmatrix} r+s & 0 \\ 0 & r+s \end{bmatrix} = \begin{bmatrix} r & 0 \\ 0 & r \end{bmatrix} + \begin{bmatrix} s & 0 \\ 0 & s \end{bmatrix} = f(r) + f(s)$$

$$\text{and } f(rs) = \begin{bmatrix} rs & 0 \\ 0 & rs \end{bmatrix} = \begin{bmatrix} r & 0 \\ 0 & r \end{bmatrix} \begin{bmatrix} s & 0 \\ 0 & s \end{bmatrix} = f(r)f(s).$$

So  $f$  is a ring isomorphism and  $\mathbf{R}$  is isomorphic to  $S$ .

5. (a) Since  $f(z_R) = z_S$ , it follows that  $z_R \in K$  and  $K \neq \emptyset$ . If  $x, y \in K$ , then  $f(x-y) = f(x + (-y)) = f(x) \oplus f(-y) = f(x) \ominus f(y) = z_S \ominus z_S = z_S$ , so  $x-y \in K$ . Finally, if  $x \in K$  and  $r \in R$ , then  $f(rx) = f(r) \odot f(x) = f(r) \odot z_S = z_S$ , and  $f(xr) = f(x) \odot f(r) = z_S \odot f(r) = z_S$ , so  $rx, xr \in K$ . Consequently,  $K$  is an ideal of  $R$ .

(b) The kernel is  $\{6n | n \in \mathbf{Z}\}$ .

(c) If  $f$  is one-to-one, then for each  $x \in K, [f(x) = z_S = f(z_R)] \implies [x = z_R]$ , so  $K = \{z_R\}$ . Conversely, if  $K = \{z_R\}$ , let  $x, y \in R$  with  $f(x) = f(y)$ : Then  $z_S = f(x) \ominus f(y) = f(x-y)$ , so  $x-y \in K = \{z_R\}$ . Consequently,  $x-y = z_R \implies x = y$ , and  $f$  is one-to-one.

6. (a)  $f[(12)(23) + 18] = f(13) \cdot f(23) + f(18) = (1, 1, 3) \cdot (1, 2, 3) + (0, 0, 3) = (1, 2, 4) + (0, 0, 3) = (1, 2, 2) = f(17)$ , so  $(13)(23) + 18 = 17$  in  $\mathbf{Z}_{30}$ .

(b)  $f[(11)(21) - 20] = f(11) \cdot f(21) - f(20) = (1, 2, 1) \cdot (1, 0, 1) - (0, 2, 0) = (1, 0, 1) - (0, 2, 0) = (1, -2, 1) = (1, 1, 1) = f(1)$ , so  $(11)(21) - 20 = 1$  in  $\mathbf{Z}_{30}$ .

(c) 24

(d) 29

7. (a)

$x$ (in $\mathbf{Z}_{20}$ )	$f(x)$ (in $\mathbf{Z}_4 \times \mathbf{Z}_5$ )	$x$ (in $\mathbf{Z}_{20}$ )	$f(x)$ (in $\mathbf{Z}_4 \times \mathbf{Z}_5$ )
0	(0,0)	10	(2,0)
1	(1,1)	11	(3,1)
2	(2,2)	12	(0,2)
3	(3,3)	13	(1,3)
4	(0,4)	14	(2,4)
5	(1,0)	15	(3,0)
6	(2,1)	16	(0,1)
7	(3,2)	17	(1,2)
8	(0,3)	18	(2,3)
9	(1,4)	19	(3,4)

(b) (i)  $f((17)(19) + (12)(14)) = (1,2)(3,4) + (0,2)(2,4) = (3,3) + (0,3) = (3,1)$  and  $f^{-1}(3,1) = 11$ .

(ii)  $f((18)(11) - (9)(15)) = (2,3)(3,1) - (1,4)(3,0) = (2,3) - (3,0) = (3,3)$  and  $f^{-1}(3,3) = 3$ .

8.  $f(ma + tb) = mf(a) + tf(b) = m(1,0) + t(0,1) = (m, t)$

9. (a) 4                      (b) 1                      (c) No

10. (a) There are  $\phi(15) = 15(2/3)(4/5) = 8$  units in both  $\mathbf{Z}_{15}$  and  $\mathbf{Z}_3 \times \mathbf{Z}_5$ .

(b) Yes. Define  $f : \mathbf{Z}_{15} \rightarrow \mathbf{Z}_3 \times \mathbf{Z}_5$  by  $f(0) = (0,0)$ ;  $f(1) = (1,1)$ ;  $f(2) = (2,2)$ ;  $f(3) = (0,3)$ ;  $f(4) = (1,4)$ ;  $f(5) = (2,0)$ ;  $f(6) = (0,1)$ ;  $f(7) = (1,2)$ ;  $f(8) = (2,3)$ ;  $f(9) = (0,4)$ ;  $f(10) = (1,0)$ ;  $f(11) = (2,1)$ ;  $f(12) = (0,2)$ ;  $f(13) = (1,3)$ ;  $f(14) = (2,4)$ . In general,  $f(x) = (a,b)$ , where  $0 \leq x \leq 14$ , and  $x \equiv a \pmod{3}$ ,  $x \equiv b \pmod{5}$ , for  $0 \leq a \leq 2$ ,  $0 \leq b \leq 4$ .

11. No,  $\mathbf{Z}_4$  has two units, while the ring in Example 14.4 has only one unit.

12. Since  $J \neq \emptyset$ ,  $f^{-1}(J) \neq \emptyset$ . If  $a_1, a_2 \in f^{-1}(J)$  then  $f(a_1), f(a_2) \in J$ . Since  $J$  is an ideal,  $f(a_1) + f(a_2) = f(a_1 + a_2) \in J$ , so  $a_1 + a_2 \in f^{-1}(J)$ . Also,  $f(a_1)f(a_2) = f(a_1a_2) \in J$ , and  $a_1a_2 \in f^{-1}(J)$ . Finally,  $a \in f^{-1}(J) \implies f(a) \in J \implies -f(a) \in J \implies f(-a) \in J \implies -a \in f^{-1}(J)$ , so  $f^{-1}(J)$  is a subring of  $R$ .

Now let  $r \in R$  and  $a \in f^{-1}(J)$ . Then  $f(ra) = f(r)f(a)$ , where  $f(r) \in S$  and  $f(a) \in J$ . Since  $J$  is an ideal of  $S$ ,  $f(ra) \in J$  and it follows that  $ra \in f^{-1}(J)$ . In a similar manner we find that  $ar \in f^{-1}(J)$ . So  $f^{-1}(J)$  is an ideal of  $R$ .

13. Here  $a_1 = 5$ ;  $a_2 = 73$ ;  $m_1 = 8$ ;  $m_2 = 81$ ;  $m = m_1m_2 = 8 \cdot 81 = 648$ ;  $M_1 = m/m_1 = 81$ ; and  $M_2 = m/m_2 = 8$ .

$$[x_1] = [M_1]^{-1} = [10(8) + 1]^{-1} = [1]^{-1} = [1] \text{ in } \mathbf{Z}_8$$

$$[x_2] = [M_2]^{-1} = [8]^{-1} = [-10] = [71] \text{ in } \mathbf{Z}_{81}$$

$$x - a_1M_1x_1 + a_2M_2x_2 = 5 \cdot 81 \cdot 1 + 73 \cdot 8 \cdot 71 = 41869 = 64(648) + 397.$$

So the smallest positive solution is 397 and all other solutions are congruent to 397 modulo 648.

$$\text{Check: } 397 = 48(8) + 3 = 4(81) + 73.$$

14. Here we want a simultaneous solution for the system of three congruences

$$\begin{aligned}x &\equiv 3 \pmod{17} \\x &\equiv 10 \pmod{16} \\x &\equiv 0 \pmod{15}.\end{aligned}$$

So  $a_1 = 2$ ;  $a_2 = 10$ ;  $a_3 = 0$ ;  $m_1 = 17$ ;  $m_2 = 16$ ;  $m_3 = 15$ ;  $m = m_1 m_2 m_3 = 17 \cdot 16 \cdot 15 = 4080$ ;  $M_1 = m/m_1 = 240$ ;  $M_2 = m/m_2 = 255$ ; and  $M_3 = m/m_3 = 272$ .

$$\begin{aligned}[x_1] &= [M_1]^{-1} = [240]^{-1} = [14(17) + 2]^{-1} = [2]^{-1} = [9] \text{ in } \mathbf{Z}_{17} \\[x_2] &= [M_2]^{-1} = [255]^{-1} = [15(16) + 15]^{-1} = [15]^{-1} = [15] \text{ in } \mathbf{Z}_{16} \\[x_3] &= [M_3]^{-1} = [272]^{-1} = [18(15) + 2]^{-1} = [2]^{-1} = [8] \text{ in } \mathbf{Z}_{15} \\x &= 3 \cdot 9 \cdot 240 + 10 \cdot 15 \cdot 255 + 0 \cdot 8 \cdot 272 = 44730 \equiv 3930 \pmod{4080}.\end{aligned}$$

So the smallest number of (identical) gold coins that could have been in the treasure chest is 3930. Any other solution is congruent to 3930 modulo 4080.

$$\text{Check: } 3930 = 231(17) + 3 = 245(16) + 10 = 262(15).$$

15. Here  $a_1 = 1$ ;  $a_2 = 2$ ;  $a_3 = 3$ ;  $a_4 = 5$ ;  $m_1 = 2$ ;  $m_2 = 3$ ;  $m_3 = 5$ ;  $m_4 = 7$ ;  $m = m_1 m_2 m_3 m_4 = 2 \cdot 3 \cdot 5 \cdot 7 = 210$ ;  $M_1 = m/m_1 = 105$ ;  $M_2 = m/m_2 = 70$ ;  $M_3 = m/m_3 = 42$  and  $M_4 = m/m_4 = 30$ .

$$\begin{aligned}[x_1] &= [M_1]^{-1} = [105]^{-1} = [52(2) + 1]^{-1} = [1]^{-1} = [1] \text{ in } \mathbf{Z}_2 \\[x_2] &= [M_2]^{-1} = [70]^{-1} = [23(3) + 1]^{-1} = [1]^{-1} = [1] \text{ in } \mathbf{Z}_3 \\[x_3] &= [M_3]^{-1} = [42]^{-1} = [8(5) + 2]^{-1} = [2]^{-1} = [3] \text{ in } \mathbf{Z}_5 \\[x_4] &= [M_4]^{-1} = [30]^{-1} = [4(7) + 2]^{-1} = [2]^{-1} = [4] \text{ in } \mathbf{Z}_7 \\x &= 1 \cdot 105 \cdot 1 + 2 \cdot 70 \cdot 1 + 3 \cdot 42 \cdot 3 + 5 \cdot 30 \cdot 4 = 1223 \equiv 173 \pmod{210}.\end{aligned}$$

So  $x = 173$  is the smallest positive simultaneous solution for the four congruences. Any other solution would be congruent to 173 modulo 210.

$$\text{Check: } 173 = 86(2) + 1 = 57(3) + 2 = 34(5) + 3 = 24(7) + 5.$$

### Supplementary Exercises

1. (a) False. Let  $R = \mathbf{Z}$  and  $S = \mathbf{Z}^+$ .
- (b) False. Let  $R = \mathbf{Z}$  and  $S = \{2x \mid x \in \mathbf{Z}\}$ .
- (c) False. Let  $R = M_2(\mathbf{Z})$  and  $S = \left\{ \begin{bmatrix} a & 0 \\ 0 & 0 \end{bmatrix} \mid a \in \mathbf{Z} \right\}$ .
- (d) True.
- (e) False.  $(\mathbf{Z}, +, \cdot)$  is a subring (but not a field) in  $(\mathbf{Q}, +, \cdot)$ .
- (f) False. For each prime  $p$ ,  $\{a/(p^n) \mid a, n \in \mathbf{Z}, n \geq 0\}$  is a subring of  $(\mathbf{Q}, +, \cdot)$ .
- (g) False. Consider the field in Table 14.6.

(h) True

2.  $R$  commutative  $\iff ba = ab$  for all  $a, b \in R \iff a^2 + ab + ba + b^2 = a^2 + 2ab + b^2$  for all  $a, b \in R \iff (a + b)^2 = a^2 + 2ab + b^2$  for all  $a, b \in R$ .

3. (a)  $a + a = (a + a)^2 = a^2 + a^2 + a^2 + a^2 = (a + a) + (a + a) \implies a + a = 2a = z$ .

(b) For each  $a \in R$ ,  $a + a = z \implies a = -a$ . For  $a, b \in R$ ,  $(a + b) = (a + b)^2 = a^2 + ab + ba + b^2 = a + ab + ba + b \implies ab + ba = z \implies ab = -ba = ba$ , so  $R$  is commutative.

4.

$$a + bi = c + di \iff a = c, b = d \iff \begin{bmatrix} a & b \\ -b & a \end{bmatrix} = \begin{bmatrix} c & d \\ -d & c \end{bmatrix},$$

so  $f$  is a one-to-one function. It is also onto. (Why?)

Further,

$$\begin{aligned} f((a + bi) + (x + yi)) &= f((a + x) + (b + y)i) \\ &= \begin{bmatrix} a + x & b + y \\ -(b + y) & a + x \end{bmatrix} = \begin{bmatrix} a & b \\ -b & a \end{bmatrix} + \begin{bmatrix} x & y \\ -y & x \end{bmatrix} \\ &= f(a + bi) + f(x + yi), \end{aligned}$$

and

$$\begin{aligned} f((a + bi)(x + yi)) &= f((ax - by) + (bx + ay)i) \\ &= \begin{bmatrix} ax - by & bx + ay \\ -(bx + ay) & ax - by \end{bmatrix} = \begin{bmatrix} a & b \\ -b & a \end{bmatrix} \begin{bmatrix} x & y \\ -y & x \end{bmatrix} \\ &= f(a + bi)f(x + yi), \end{aligned}$$

so  $f$  is a ring isomorphism.

5. Since  $az = z = za$  for all  $a \in R$ , we have  $z \in C$  and  $C \neq \emptyset$ . If  $x, y \in C$ , then  $(x + y)a = xa + ya = ax + ay = a(x + y)$ ,  $(xy)a = x(ya) = x(ay) = (xa)y = (ax)y$ , and  $(-x)a = -(xa) = -(ax) = a(-x)$ , for all  $a \in R$ , so  $x + y, xy$ , and  $-x \in C$ . Consequently,  $C$  is a subring of  $R$ .

6. (a) (i)  $2^4$  (ii)  $3^4$  (iii)  $p^4$

(b) (i)  $(2^2 - 1)(2^2 - 2) = (3)(2) = 6$

(ii)  $(3^2 - 1)(3^2 - 3) = (8)(6) = 48$

(iii)  $(p^2 - 1)(p^2 - p)$

7. (a) Since  $a^3 = b^3$  and  $a^5 = b^5$ , it follows that  $a^5 = (b^3)(b^2) = (a^3)(b^2)$ . Consequently,  $(a^3)(a^2) = (a^3)(b^2)$  with  $a^3 \neq z$ , so  $a^2 = b^2$ .

Now with  $a^3 = b^3$  and  $a^2 = b^2$  we have  $(a^2)(a) = a^3 = b^3 = (b^2)(b) = (a^2)(b)$ , and since  $a^2 \neq z$  it follows that  $a = b$ .

(b) Since  $m, n$  are relatively prime we can write  $1 = ms + nt$  where  $s, t \in \mathbb{Z}$ . With  $m, n > 0$  it follows that one of  $s, t$  must be positive, and the other negative. Assume (without any loss of generality) that  $s$  is negative so that  $1 - ms = nt > 0$ .

Then  $a^n = b^n \implies (a^n)^t = (b^n)^t \implies a^{nt} = b^{nt} \implies a^{1-ms} = b^{1-ms} \implies a(a^m)^{-s} = b(b^m)^{-s}$ . But with  $-s > 0$  and  $a^m = b^m$ , we have  $(a^m)^{-s} = (b^m)^{-s}$ . Consequently,

$$(((a^m)^{-s} = (b^m)^{-s}) \neq z] \wedge [a(a^m)^{-s} = b(b^m)^{-s}]) \implies a = b,$$

since we may use the Cancellation Law of Multiplication in an integral domain.

8. (a)  $\mathbb{R}^+$  is closed under  $\oplus$  and  $\odot$ . For all  $a, b, c \in \mathbb{R}^+$ ,  $a \oplus b = ab = ba = b \oplus a$ ;  $a \oplus (b \oplus c) = a \oplus (bc) = a(bc) = (ab)c = (ab) \oplus c = (a \oplus b) \oplus c$ ; and  $a \oplus 1 = 1 \oplus a = a$ , so  $\oplus$  is commutative and associative with additive identity 1. Also, for each  $a \in \mathbb{R}^+$ ,  $a^{-1} \in \mathbb{R}^+$ , and  $a^{-1}$  is the (additive) inverse of  $a$ .

Now consider  $\odot$ . For  $a, b, c \in \mathbb{R}^+$ ,  $a \odot (b \odot c) = a \odot (b^{\log_2 c}) = a^{\log_2 (b^{\log_2 c})} = a^{(\log_2 c)(\log_2 b)}$  and  $(a \odot b) \odot c = (a^{\log_2 b}) \odot c = a^{(\log_2 b)(\log_2 c)}$ , so  $\odot$  is associative. Also, for  $a, b \in \mathbb{R}^+$ ,  $\log_2 b \log_2 a = \log_2 a \log_2 b \implies \log_2 [a^{\log_2 b}] = \log_2 [b^{\log_2 a}] \implies a^{\log_2 b} = b^{\log_2 a} \implies a \odot b = b \odot a$ , so  $\odot$  commutative. In addition,  $a \odot 2 = a^{\log_2 2} = a^1 = a$  for all  $a \in \mathbb{R}^+$  so 2 is the multiplicative identity. Finally,  $a \odot (b \oplus c) = a \odot (bc) = a^{\log_2 (bc)} = a^{\log_2 b + \log_2 c} = (a^{\log_2 b})(a^{\log_2 c}) = (a \odot b) \oplus (a \odot c)$ , so the distributive law holds and  $(\mathbb{R}^+, \oplus, \odot)$  is a commutative ring with unity.

(b) For each  $a \in \mathbb{R}^+$ ,  $a \neq 1$ , we find that  $a \odot 2^{\log_2 a} = a^{\log_2 (2^{\log_2 a})} = a^{(\log_2 2)(\log_2 a)} = a^{\log_2 a} = 2$ , the unity of the ring. So  $(\mathbb{R}^+, \oplus, \odot)$  is a field.

9. Let  $x = a_1 + b_1$ ,  $y = a_2 + b_2$ , for  $a_1, a_2 \in A$ ,  $b_1, b_2 \in B$ . Then  $x - y = (a_1 - a_2) + (b_1 - b_2) \in A + B$ . If  $r \in R$ , and  $a + b \in A + B$ , with  $a \in A$ ,  $b \in B$ , then  $ra \in A$ ,  $rb \in B$  and  $r(a + b) \in A + B$ . Similarly,  $(a + b)r \in A + B$ , and  $A + B$  is an ideal of  $R$ .
10. (a) For  $0 < k < p$ ,  $\binom{p}{k} = \frac{p!}{k!(p-k)!} = p \frac{(p-1)!}{k!(p-k)!}$ .  $[(p-1)! / (k!(p-k)!)]$  is an integer because for any  $0 < k < p$ , none of  $2, 3, \dots, \max\{k, p-k\}$  divides  $p$  when  $p$  is prime.
- (b)  $(a + b)^p = \sum_{k=0}^p \binom{p}{k} a^k b^{p-k}$ . By part (a)  $\binom{p}{k} \equiv 0 \pmod{p}$  for  $0 < k < p$ , so  $(a + b)^p \equiv a^p + b^p \pmod{p}$ .
11. Consider the numbers  $x_1, x_1 + x_2, x_1 + x_2 + x_3, \dots, x_1 + x_2 + x_3 + \dots + x_n$ . If one of these numbers is congruent to 0 modulo  $n$ , the result follows. If not, there exist  $1 \leq i < j \leq n$  with  $(x_1 + x_2 + \dots + x_i) \equiv (x_1 + \dots + x_i + x_{i+1} + \dots + x_j) \pmod{n}$ . Hence  $n$  divides  $(x_{i+1} + \dots + x_j)$ .
12. Since  $2 = 1 + 1$  and  $3 = 4 - 1$  we know that  $(2, 1, 1)$  and  $(3, 4, -1)$  are elements in  $S$ . However,  $(2, 1, 1) \odot (3, 4, -1) = (2 \cdot 3, 1 \cdot 4, 1 \cdot (-1)) = (6, 4, -1)$ , and  $(6, 4, -1)$  is not in  $S$  because  $6 \neq 4 + (-1)$ . Consequently,  $S$  is not closed under multiplication so it is not a subring of  $(\mathbb{Z}^3, \oplus, \odot)$ .

[Note: The set  $S$  is nonempty and it is closed under subtraction.]

13. (a) For each  $t \in \mathbb{N}$ ,

$$\begin{array}{ll} 7^{4t+1} \equiv 7 \pmod{10} & 3^{4t+1} \equiv 3 \pmod{10} \\ 7^{4t+2} \equiv 9 \pmod{10} & 3^{4t+2} \equiv 9 \pmod{10} \\ 7^{4t+3} \equiv 3 \pmod{10} & 3^{4t+3} \equiv 7 \pmod{10} \\ 7^{4t+4} \equiv 1 \pmod{10} & 3^{4t+4} \equiv 1 \pmod{10} \end{array}$$

So in order to get the units digit of  $7^m + 3^n$  as 8 we must have (i)  $m \equiv 1 \pmod{4}$  and  $n \equiv 0 \pmod{4}$ , or (ii)  $m \equiv 0 \pmod{4}$  and  $n \equiv 3 \pmod{4}$ , or (iii)  $m \equiv 2 \pmod{4}$  and  $n \equiv 2 \pmod{4}$ .

For case (i) there are 25 choices for  $m$  (namely, 1, 5, 9, ..., 93, 97) and 25 choices for  $n$  (namely, 4, 8, 12, ..., 96, 100) — a total of  $25^2 = 625$  choices for the pair. There are also 625 choices for the pair in each of cases (ii) and (iii). Consequently, in total, there are  $625 + 625 + 625 = 1875$  ways to make the selection for  $m, n$ .

(b) For case (i) there are 32 choices for  $m$  and 31 choices for  $n$ , and  $32 \times 31 = 992$  choices for the pair. There are 31 choices for each of  $m, n$ , resulting in  $31^2 = 961$  possible pairs, for case (ii) and case (iii). Therefore we can select  $m, n$  in this situation in  $992 + 961 + 961 = 2914$  ways.

(c) There are  $(100)^2 = 10,000$  ways in which one can select the pair  $m, n$ .

Here we consider three cases:

- (i)  $m \equiv 2 \pmod{4}$  and  $n \equiv 1 \pmod{4}$ ;
- (ii)  $m \equiv 3 \pmod{4}$  and  $n \equiv 2 \pmod{4}$ ; and
- (iii)  $m \equiv 0 \pmod{4}$  and  $n \equiv 0 \pmod{4}$ .

For each case there are  $(25)^2 = 625$  ways to select the pair  $m, n$ . Therefore, we have 1875 ways in total.

Consequently, the probability for the problem posed is  $\frac{1875}{10,000} = 0.1875 = 3\left[\left(\frac{25}{100}\right)\left(\frac{25}{100}\right)\right] = 3/16$ .

14. Proof:

(a) For  $n = 2$  and  $k = 1$  we have  $1^3 = 1$ , and  $1^3 \equiv 1 \pmod{2}$ . When  $n > 2$  then  $k^3 - k = k(k^2 - 1) = k(k - 1)(k + 1) \neq 0$ , where  $k - 1$  and  $k + 1$  are both even. Hence  $n = 2k$  divides  $k^3 - k$ , so  $k^3 \equiv k \pmod{n}$ .

(b) When  $n = 4k$  it follows that  $(2k)^3 = (4k)(2k^2) = n(2k^2) \equiv 0 \pmod{n}$ .

(c) Recall that for all real numbers  $x, y$  we have  $x^3 + y^3 = (x + y)(x^2 - xy + y^2)$ .

(i) If  $n$  is even with  $n/2$  odd, then  $\sum_{i=1}^{n-1} i^3 = 1^3 + 2^3 + \dots + \left(\frac{n}{2} - 1\right)^3 + \left(\frac{n}{2}\right)^3 + \left(\frac{n}{2} + 1\right)^3 + \dots + (n - 1)^3$ .

Consider the following pairs:

$$\begin{array}{rcl}
 1^3 + (n-1)^3 & = & [1 + (n-1)][1^2 - 1(n-1) + (n-1)^2] \equiv 0 \pmod{n} \\
 \vdots & & \vdots \\
 2^3 + (n-2)^3 & = & [2 + (n-2)][2^2 - 2(n-2) + (n-2)^2] \equiv 0 \pmod{n} \\
 \vdots & & \vdots \\
 (\frac{n}{2}-1)^3 + (\frac{n}{2}+1)^3 & = & [(\frac{n}{2}-1) + (\frac{n}{2}+1)][(\frac{n}{2}-1)^2 - (\frac{n}{2}-1)(\frac{n}{2}+1) + (\frac{n}{2}+1)^2] \equiv 0 \pmod{n}.
 \end{array}$$

Hence  $\sum_{i=1}^{n-1} i^3 \equiv (\frac{n}{2})^3 \equiv (\frac{n}{2}) \pmod{n}$ , for  $n$  even with  $n/2$  odd — by virtue of part (a).

(ii) If  $n$  is even and divisible by 4, then by an argument similar to that in part (i) we have

$$\sum_{i=1}^{n-1} i^3 \equiv (\frac{n}{2})^3 \equiv 0 \pmod{n} \text{ — because of part (b).}$$

(iii) Finally, consider the case where  $n$  is odd. By an argument similar to the one in part

(i) we have  $\sum_{i=1}^{n-1} i^3 = \sum_{i=1}^{(n-1)/2} [i^3 + (n-i)^3] = \sum_{i=1}^{(n-1)/2} (i + (n-i))[i^2 - i(n-i) + (n-i)^2]$ , where each summand has the factor  $n$  — making it congruent to 0 modulo  $n$ . Consequently,  $\sum_{i=1}^{n-1} i^3 \equiv 0 \pmod{n}$ .

15. Proof: For all  $n \in \mathbf{Z}$  we find that  $n^2 \equiv 0 \pmod{5}$  — when  $5|n$  — or  $n^2 \equiv 1 \pmod{5}$  or  $n^2 \equiv 4 \pmod{5}$ . Suppose that 5 does not divide any of  $a, b$ , or  $c$ . Then

(i)  $a^2 + b^2 + c^2 \equiv 3 \pmod{5}$  — when  $a^2 \equiv b^2 \equiv c^2 \equiv 1 \pmod{5}$ ;

(ii)  $a^2 + b^2 + c^2 \equiv 1 \pmod{5}$  — when each of two of  $a^2, b^2, c^2$  is congruent to 1 modulo 5 and the other square is congruent to 4 modulo 5;

(iii)  $a^2 + b^2 + c^2 \equiv 4 \pmod{5}$  — when one of  $a^2, b^2, c^2$  is congruent to 1 modulo 5 and each of the other two squares is congruent to 4 modulo 5; or,

(iv)  $a^2 + b^2 + c^2 \equiv 2 \pmod{5}$  — when  $a^2 \equiv b^2 \equiv c^2 \equiv 4 \pmod{5}$ .

16.

Program Reversal (input, output);

Var

posint, rightdigit: integer;

Begin

Writeln ('Input the positive integer whose digits are to be reversed.');

Read (posint);

Write ('The reversal of ', posint:0, ' is ');

While posint > 0 do

Begin

    rightdigit := posint Mod 10;

    Write (rightdigit:0);

    posint := posint Div 10

End;  
Writeln

End.

17. From Section 4.5 we know that  $a - b$  has  $(e_1 + 1)(e_2 + 1) \cdots (e_k + 1)$  positive integer divisors. Consequently, there are  $(e_1 + 1)(e_2 + 1) \cdots (e_k + 1) - 1$  possible values for  $n$  which will make  $a \equiv b \pmod{n}$  true.
18. We use the Chinese Remainder Theorem to find a simultaneous solution for the system of three congruences:

$$\begin{aligned}x &\equiv 3 \pmod{8} \\x &\equiv 4 \pmod{11} \\x &\equiv 5 \pmod{15}.\end{aligned}$$

Here  $a_1 = 3$ ;  $a_2 = 4$ ;  $a_3 = 5$ ;  $m_1 = 8$ ;  $m_2 = 11$ ;  $m_3 = 15$ ;  $m = m_1 m_2 m_3 = 8 \cdot 11 \cdot 15 = 1320$ ;  $M_1 = m/m_1 = 165$ ;  $M_2 = m/m_2 = 120$ ; and  $M_3 = m/m_3 = 88$ .

$$[x_1] = [M_1]^{-1} = [165]^{-1} = [20(8) + 5]^{-1} = [5]^{-1} = [5] \text{ in } \mathbf{Z}_8$$

$$[x_2] = [M_2]^{-1} = [120]^{-1} = [10(11) + 10]^{-1} = [10]^{-1} = [10] \text{ in } \mathbf{Z}_{11}$$

$$[x_3] = [M_3]^{-1} = [88]^{-1} = [5(15) + 13]^{-1} = [13]^{-1} = [7] \text{ in } \mathbf{Z}_{15}$$

$$x = 3 \cdot 165 \cdot 240 + 4 \cdot 120 \cdot 10 + 5 \cdot 88 \cdot 7 = 10355 = 7(1320) + 1115 \equiv 1115 \pmod{1320}.$$

So  $x = 1115$  is the smallest number of freshman that Jerina and Noor could be trying to organize for the pregame presentation.

Check:  $1115 = 139(8) + 3 = 101(11) + 4 = 74(15) + 5$ .

**CHAPTER 15**  
**BOOLEAN ALGEBRA AND SWITCHING FUNCTIONS**

**Section 15.1**

1. (a) 1                      (b) 1                      (c) 1                      (d) 1
2. (a) Since  $x$  has value 1,  $x + xy + w$  has value 1 regardless of the values of  $y$  and  $w$ .  
 (b) Three assignments: (1)  $y : 1, w : 1$ ; (2)  $y : 0, w : 1$ ; and (3)  $y : 1, w : 0$ .  
 (c) Two assignments: (1)  $y : 1, w : 1$ ; (2)  $y : 0, w : 1$ .  
 (d) Two assignments: (1)  $y : 1, w : 1$ ; (2)  $y : 0, w : 1$ .

3. (a)  $2^n$                       (b)  $2^{(2^n)}$

4. a) (i)  $\bar{w} \bar{x} y z$                       (ii)  $\bar{w} x y \bar{z}$   
 (iii)  $\bar{w} x y z$                       (iv)  $\bar{w} \bar{x} \bar{y} \bar{z}$
- b) (i)  $w + x + \bar{y} + \bar{z}$                       (ii)  $w + \bar{x} + \bar{y} + z$   
 (iii)  $w + \bar{x} + \bar{y} + \bar{z}$                       (iv)  $w + x + y + z$

5.

$x$	$y$	$z$	$\overline{x + y}$	$\bar{x}z$	$\overline{(x + y) + (\bar{x}z)}$
0	0	0	1	0	0
0	0	1	1	1	0
0	1	0	0	0	1
0	1	1	0	1	0
1	0	0	0	0	1
1	0	1	0	0	1
1	1	0	0	0	1
1	1	1	0	0	1

- (a) d.n.f.                       $xyz + x\bar{y}z + x\bar{y}\bar{z} + xy\bar{z} + \bar{x}y\bar{z}$   
 c.n.f.                       $(x + y + z)(x + y + \bar{z})(x + \bar{y} + \bar{z})$

(b)  $f = \sum m(2, 4, 5, 6, 7) = \prod M(0, 1, 3)$

6. a)  $g(w, x, y, z) = (wz + xyz)(x + \bar{x}\bar{y}z) = wxz + xyz + w\bar{x}\bar{y}z = wx(y + \bar{y})z + (w + \bar{w})xyz + w\bar{x}\bar{y}z = wxyz + wx\bar{y}z + wxy\bar{z} + \bar{w}xyz + w\bar{x}\bar{y}z$ . Consequently, the d.n.f. for  $g$  is  $wxyz + wx\bar{y}z + \bar{w}xyz + w\bar{x}\bar{y}z$ , a sum of four minterms.

From the d.n.f. for  $g$  we know that the c.n.f. for  $g$  is a product of 12 maxterms. The binary labels for the above minterms are

$$\begin{array}{ll} wxyz: & 1111(=15) & wx\bar{y}z: & 1101(=13) \\ \bar{w}xyz: & 0111(=7) & w\bar{x}\bar{y}z: & 1001(=9) \end{array}$$

Consequently we have the maxterms

0000(=0)	$w + x + y + z$	0001(=1)	$w + x + y + \bar{z}$	0010(=2)	$w + x + \bar{y} + z$
0110(=3)	$w + x + \bar{y} + \bar{z}$	0100(=4)	$w + \bar{x} + y + z$	0101(=5)	$w + \bar{x} + y + \bar{z}$
0110(=6)	$w + \bar{x} + \bar{y} + z$	1000(=8)	$\bar{w} + x + y + z$	1010(=10)	$\bar{w} + x + \bar{y} + z$
1011(=11)	$\bar{w} + x + \bar{y} + \bar{z}$	1100(=12)	$\bar{w} + \bar{x} + y + z$	1110(=14)	$\bar{w} + \bar{x} + \bar{y} + z$

and the c.n.f. for  $g$  is the product of these 12 maxterms.

$$b) \quad g = \sum m(7, 9, 13, 15) = \prod M(0, 1, 2, 3, 4, 5, 6, 8, 10, 11, 12, 14)$$

7. (a)  $2^{64}$                       (b)  $2^6$                       (c)  $2^6$
8. (a)  $f(w, x, y, z) = \bar{w}x\bar{y}z + \bar{w}xy\bar{z} + w\bar{x}\bar{y}\bar{z} + w\bar{x}yz$   
 (b)  $f(w, x, y, z) = \bar{w}\bar{x}yz + \bar{w}x\bar{y}z + \bar{w}xyz + w\bar{x}y\bar{z} + w\bar{x}yz + wx\bar{y}\bar{z} + wx\bar{y}z + wxy\bar{z} + wxyz$
9.  $m + k = 2^n$
10. If  $x = 0$ , then  $x + y + z = xyz \implies x + y + z = 0 \implies y = z = 0$ .  
 If  $x = 1$ , then  $x + y + z = xyz \implies 1 = xyz \implies y = z = 1$ .
11. (a)  $xy + (x + y)\bar{z} + y = y(x + 1) + (x + y)\bar{z} = y + x\bar{z} + y\bar{z} = y(1 + \bar{z}) + x\bar{z} = y + x\bar{z}$ .  
 (b)  $x + y + \overline{(\bar{x} + y + z)} = x + y + (x\bar{y}\bar{z}) = x(1 + \bar{y}\bar{z}) + y = x + y$ .  
 (c)  $yz + wz + z + [wz(xy + wz)] = z(y + 1) + wx + wxyz + wz = z + wx(1 + yz) + wz = z + wx + wz = z(1 + w) + wx = z + wx$ .
12.  $x + \bar{x}y = 0 \implies x = 0 = \bar{x}y \implies x = y = 0$ ;  $\bar{x}y = \bar{x}z, x = y = 0 \implies z = 0$ ;  $\bar{x}y + \bar{x}\bar{z} + zw = \bar{x}w, x = y = z = 0 \implies w = 1$ .

13. (a)

	$f$	$g$	$h$	$fg$	$\bar{f}h$	$gh$	$fg + \bar{f}h + gh$	$fg + \bar{f}h$
	0	0	0	0	0	0	0	0
	0	0	1	0	1	0	1	1
	0	1	0	0	0	0	0	0
(i)	0	1	1	0	1	1	1	1
	1	0	0	0	0	0	0	0
	1	0	1	0	0	0	0	0
	1	1	0	1	0	0	1	1
	1	1	1	1	0	1	1	1

Alternately,  $fg + \bar{f}h = (fg + \bar{f})(fg + h) = (f + \bar{f})(g + \bar{f})(fg + h) = 1(g + \bar{f})(fg + h) = fg + gh + \bar{f}fg + \bar{f}h = fg + gh + 0g + \bar{f}h = fg + gh + \bar{f}h$ .

(ii)  $fg + f\bar{g} + \bar{f}g + \bar{f}\bar{g} = f(g + \bar{g}) + \bar{f}(g + \bar{g}) = f \cdot 1 + \bar{f} \cdot 1 = f + \bar{f} = 1$

(b) (i)  $(f + g)(f + h)(g + h) = (f + g)(\bar{f} + h)$

(ii)  $(f + g)(f + \bar{g})(\bar{f} + g)(\bar{f} + \bar{g}) = 0$

14. (a) For any  $f \in F_n$ ,  $f$  has value 1 whenever  $f$  has value 1 so the relation is reflexive. If  $f, g \in F_n$  and  $f \leq g$  and  $g \leq f$ , then if  $f$  has value 1 for a certain assignment of Boolean values to its  $n$  variables,  $g$  also has value 1 since  $f \leq g$ . Likewise, when  $g$  has value 1,  $f$  does also, since  $g \leq f$ . So  $f$  and  $g$  have the value 1 simultaneously and  $f = g$ , making the relation antisymmetric. Finally, if  $f, g, h \in F_n$  with  $f \leq g$  and  $g \leq h$ , then if  $f$  has the value 1 so does  $g$  (since  $f \leq g$ ) and so does  $h$  (since  $g \leq h$ ). Hence  $f \leq h$  and the relation is transitive.

(b)  $fg$  has the value 1 iff  $f, g$  both have value 1 so  $fg \leq f$ . When  $f$  has the value 1 so does  $f + g$ , so  $f \leq f + g$ .

(c)

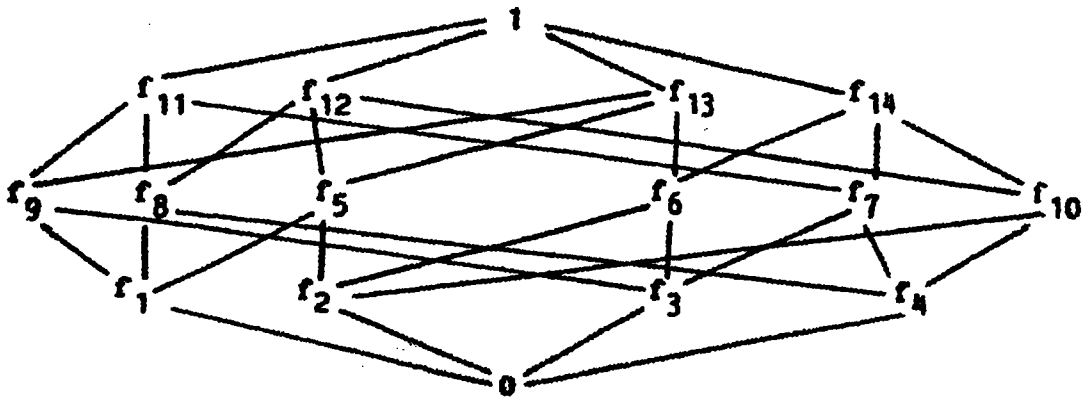

Minterms

$$f_1(x, y) = xy$$

$$f_2(x, y) = \bar{x}y$$

$$f_3(x, y) = \bar{x}\bar{y}$$

$$f_4(x, y) = x\bar{y}$$

Maxterms

$$f_{11}(x, y) = x + \bar{y}$$

$$f_{12}(x, y) = x + y$$

$$f_{13}(x, y) = \bar{x} + y$$

$$f_{14}(x, y) = \bar{x} + \bar{y}$$

$$f_5(x, y) = y, f_6(x, y) = \bar{x},$$

$$f_7(x, y) = \bar{y}, f_8(x, y) = x,$$

$$f_9(x, y) = xy + \bar{x}\bar{y}$$

$$f_{10}(x, y) = \bar{x}y + x\bar{y}$$

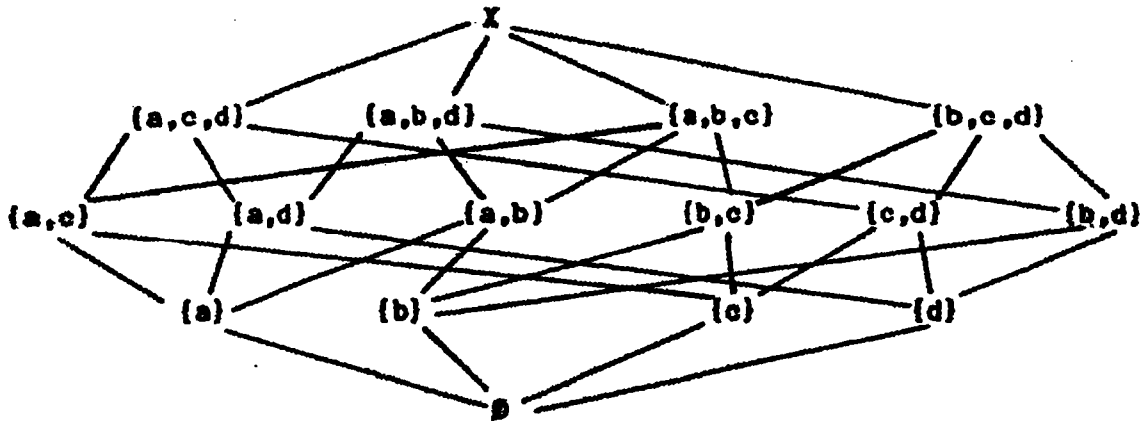
Let  $X = \{a, b, c, d\}$ 

Ignoring the labels at the vertices, these Hasse diagrams are structurally the same.

15. (a)  $f \oplus f = 0$ ;  $f \oplus \bar{f} = 1$ ;  $f \oplus 1 = \bar{f}$ ;  $f \oplus 0 = f$

(b) (i)  $f \oplus g = 0 \Leftrightarrow f\bar{g} + \bar{f}g = 0 \Rightarrow f\bar{g} + \bar{f}g = 0$ .  $\{f = 1, \text{ and } f\bar{g} = 0\} \Rightarrow g = 1$ .  
 $\{f = 0 \text{ and } \bar{f}g = 0\} \Rightarrow g = 0$ . Hence  $f = g$ .

(iii)  $\bar{f} \oplus \bar{g} = \overline{f\bar{g}} + \overline{\bar{f}g} = \bar{f}g + f\bar{g} = f\bar{g} + \bar{f}g = f \oplus g$

(iv) This is the only result that is not true. When  $f$  has value 1,  $g$  has value 0 and  $h$  value 1 (or  $g$  has value 1 and  $h$  value 0), then  $f \oplus gh$  has value 1 but  $(f \oplus g)(f \oplus h)$  has value 0.

(v)  $fg \oplus fh = \overline{f\bar{g}}fh + fg\overline{\bar{h}} = (\bar{f} + \bar{g})fh + fg(\bar{f} + \bar{h}) = \bar{f}fh + f\bar{g}h + f\bar{f}g + fg\bar{h} =$

$$f\bar{g}h + fg\bar{h} = f(\bar{g}h + g\bar{h}) = f(g \oplus h).$$

$$(vi) \quad \bar{f} \oplus g = \bar{f}\bar{g} + fg = fg + \bar{f}\bar{g} = f \oplus \bar{g}.$$

$$\overline{f \oplus g} = \overline{f\bar{g} + \bar{f}g} = (\bar{f} + g)(f + \bar{g}) = \bar{f}\bar{g} + fg = \bar{f} \oplus g.$$

$$(vii) \quad [f \oplus g = f \oplus h] \Rightarrow [f \oplus (f \oplus g) = f \oplus (f \oplus h)] \Rightarrow [(f \oplus f) \oplus g = (f \oplus f) \oplus h] \Rightarrow [0 \oplus g = 0 \oplus h] \Rightarrow [g = h].$$

**Section 15.2**

1. (a)  $x \oplus y = (x + y)(\bar{x}y)$

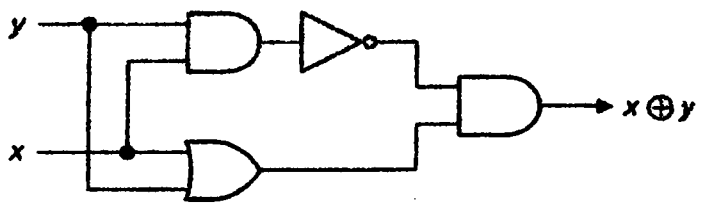

(b)  $\bar{x}y$

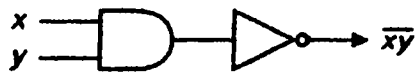

(c)  $\overline{x + y}$



2. (a)



(b)

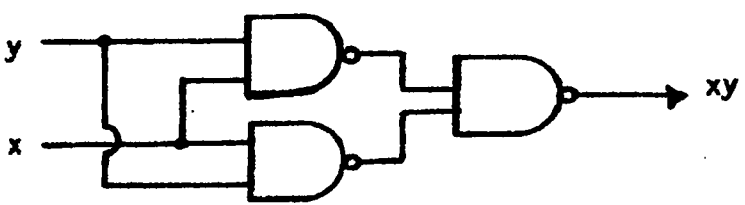

(c)

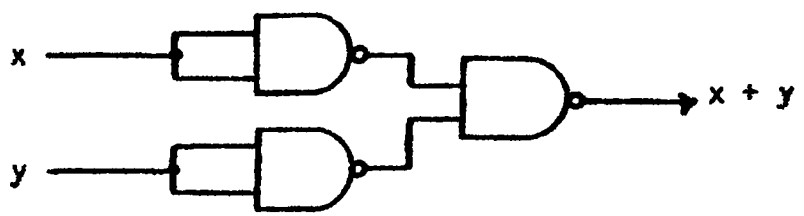

3. (a)



(b)

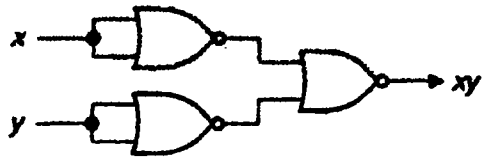

(c)

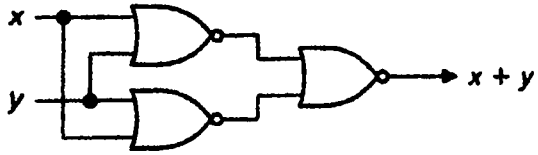

4. (a)

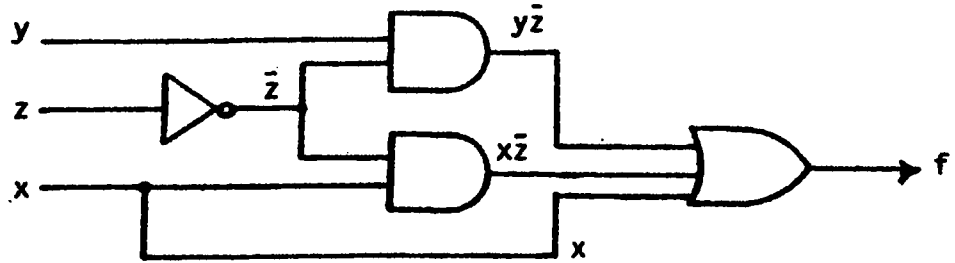

(b)

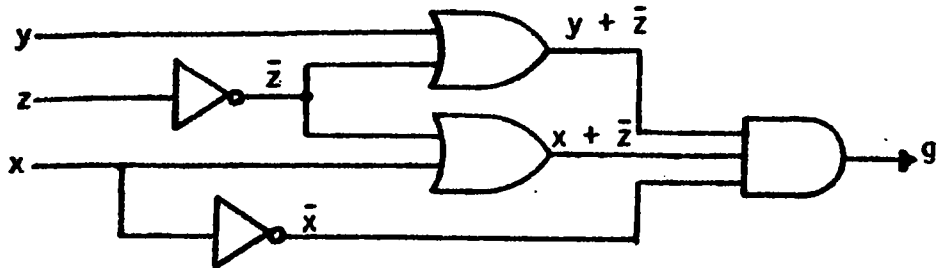

(c)

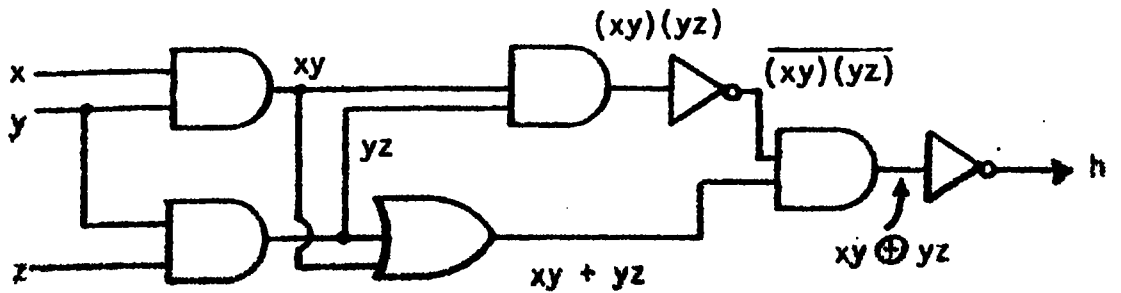

5.  $f(w, x, y, z) = \bar{w} \bar{x} y \bar{z} + (w + x + \bar{y})z$

6. (a)

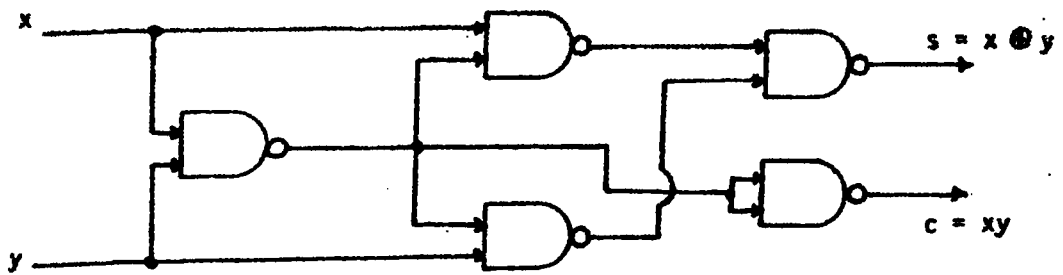

(b)

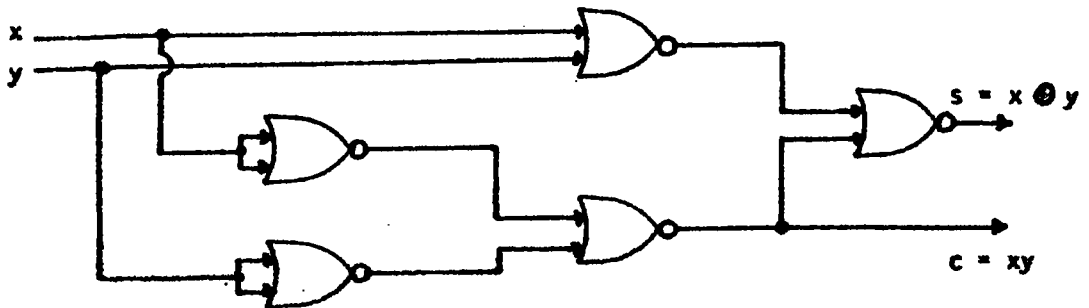

7. a) The output is  $(x + \bar{y})(x + y) + y$ . This simplifies to  $x + (\bar{y}y) + y = x + 0 + y = x + y$  and provides us with the simpler equivalent network in part (a) of the figure.

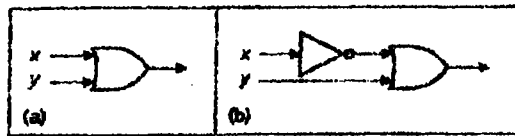

b) Here the output is  $\overline{(x + \bar{y})} + (\bar{x} \bar{y} + y)$  which simplifies to  $\bar{x} \bar{y} + \bar{x} \bar{y} + y = \bar{x} \bar{y} + \bar{x} \bar{y} + y = \bar{x}(y + \bar{y}) + y = \bar{x}(1) + y = \bar{x} + y$ . This accounts for the simpler equivalent network in part (b) of the figure.

8. (b)

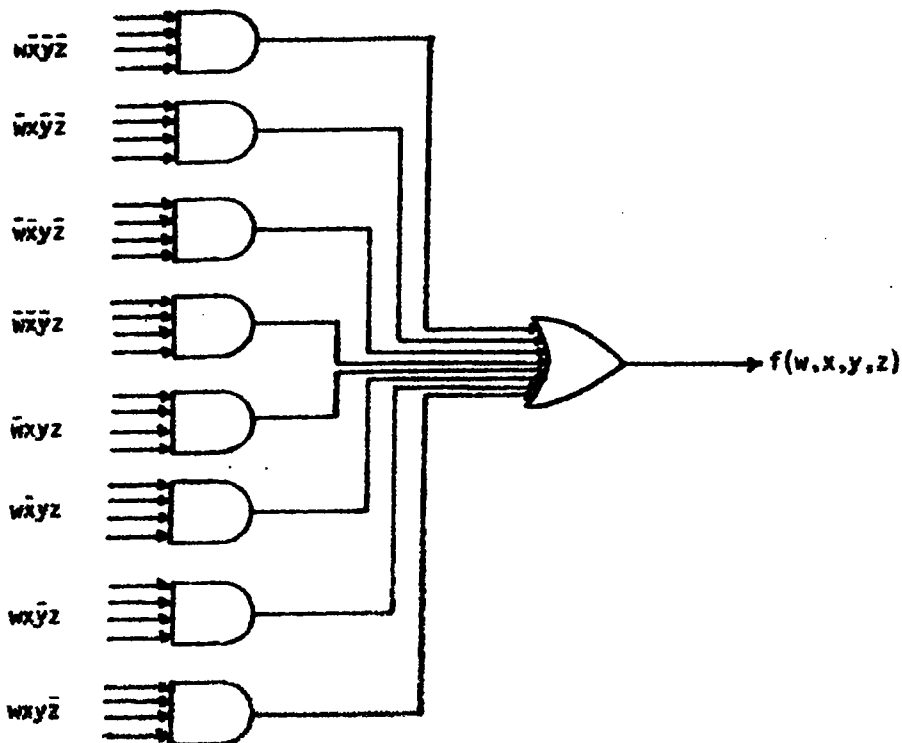

9. (a)

$w \backslash xy$	00	01	11	10
0		1		1
1		1		1

$$f(w, x, y) = \bar{x}y + x\bar{y}$$

(b)  $f(w, x, y) = x$

(c)

$wx \backslash yz$	00	01	11	10
00	1			1
01		1	1	
11		1	1	
10	1			1

$$f(w, x, y, z) = xz + \bar{x}\bar{z}$$

(d)  $f(w, x, y, z) = xz + \bar{x}\bar{z} + w\bar{y}z$  or  $xz + \bar{x}\bar{z} + w\bar{x}\bar{y}$

(e)

$wx \backslash yz$	00	01	11	10
00				
01		1		1
11	1	1	1	1
10	1			

$$f(w, x, y, z) = w\bar{y}\bar{z} + x\bar{y}z + wyz + xy\bar{z}$$

(f)

$wx \backslash yz$	00	01	11	10	$wx \backslash yz$	00	01	11	10
00		1	1	1	00	1	1	1	
01	1				01		1	1	
11					11	1	1	1	1
10				1	10		1		1

$$f(v, w, x, y, z) = \bar{v}\bar{w}\bar{x}\bar{y}\bar{z} + vxz\bar{z} + \bar{v}\bar{x}\bar{y}\bar{z} + \bar{w}\bar{x}\bar{z} + v\bar{w}y + vyz$$

10.

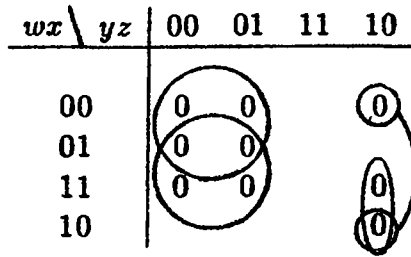

$$f(w, x, y, z) = (w + y)(\bar{x} + y)(\bar{w} + \bar{y} + z)(x + \bar{y} + z)$$

11. (a) 2            (b) 3            (c) 4            (d)  $k + 1$

12. (a) 64            (b) 32            (c) 16            (d) 8

13.

(a) $ f^{-1}(0)  =  f^{-1}(1)  = 8$	(b) $ f^{-1}(0)  = 12,  f^{-1}(1)  = 4$
(c) $ f^{-1}(0)  = 14,  f^{-1}(1)  = 2$	(d) $ f^{-1}(0)  = 4,  f^{-1}(1)  = 12$
(e) $ f^{-1}(0)  = 6,  f^{-1}(1)  = 10$	(f) $ f^{-1}(0)  = 7,  f^{-1}(1)  = 9$

### Section 15.3

1.  $f(u, v, w, x, y, z) = (v + w + x + y)(u + w)(v + z)(u + y + z) =$   
 $(uv + uw + ux + uy + vw + w + wx + wy)(v + z)(u + y + z) =$   
 $(uv + ux + uy + (u + v + 1 + x + y)w)(v + z)(u + y + z) =$   
 $(uv + ux + uy + w)(uv + vy + vz + uz + yz + z) =$   
 $(uv + ux + uy + w)(uv + vy + z) =$   
 $(uv + uvx + uvy + uvw + uvz + uvxy + uvy + wvy + uvz + uxz + uyz + wz) =$   
 $uv + wvy + uxz + uyz + wz$

2. Due to the size of this table we show only two of the simplifications.

$cd \backslash ef$	00	01	11	10
00	0	0	0	0
01	0	1	1	1
11	0	1	1	1
10	0	1	1	0

$(a = 0, b = 0)$

$cd \backslash ef$	00	01	11	10
00	0	0	0	0
01	1	1	1	1
11	1	1	1	1
10	0	1	1	1

$(a = 1, b = 0)$

$cd \backslash ef$	00	01	11	10
00	0	1	1	1
01	0	1	1	1
11	0	1	1	1
10	0	1	1	1

$(a = 0, b = 1)$

$cd \backslash ef$	00	01	11	10
00	0	1	1	1
01	1	1	1	1
11	1	1	1	1
10	0	1	1	1

$(a = 1, b = 1)$

$g(a, b, c, d, e, f) = bf + be + ad + df + de + cf + ace$

3. (a)

$wx \backslash yz$	00	01	11	10
00		1	1	
01		1	1	
11	✓	✓	✓	✓
10		1	✓	✓

$f(w, x, y, z) = z$

(b)

$wx \backslash yz$	00	01	11	10
00	1			
01	✓	1		1
11		1		1
10	1	✓	✓	

$f(w, x, y, z) = \bar{x}\bar{y}\bar{z} + x\bar{y}z + xy\bar{z}$

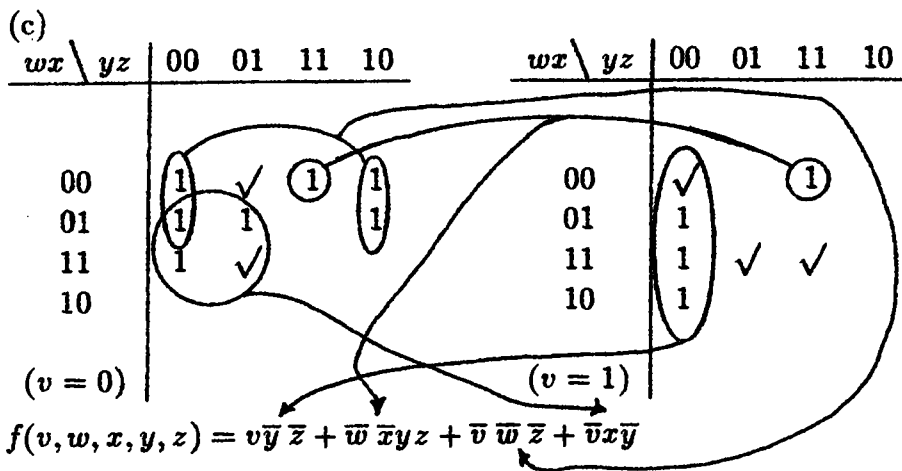

4. (a)  $f(a, b, c, e) = \bar{a}\bar{b}\bar{c}\bar{e} (2) + \bar{a}\bar{b}ce (3) + \bar{a}b\bar{c}e (5) + \bar{a}bce (7) + a\bar{b}ce (11) + ab\bar{c}e (13)$   
 (b)  $f = \sum m(2, 3, 5, 7, 11, 13)$

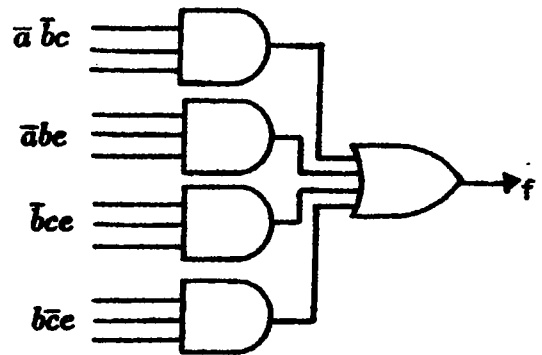
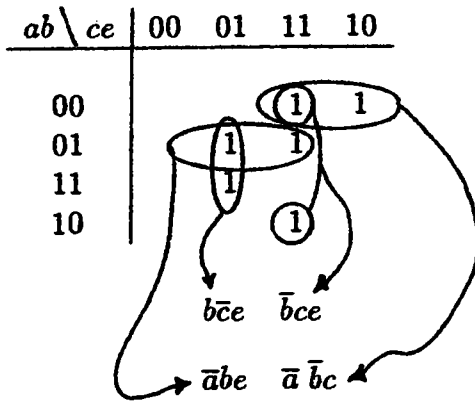

- (c)  $f = \sum m(2, 3, 5, 7) + d(10, 11, 12, 13, 14, 15)$

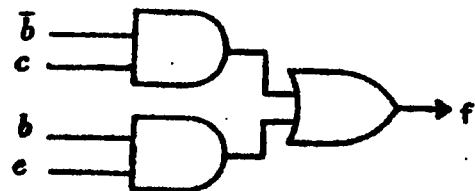
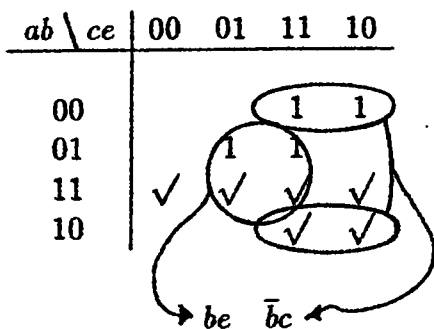

5. (a)  $(a+b+c+d+e)(a+b+c+f)(a+b+c+d+f)(a+c+d+e+g) \cdot$   
 $(a+d+e+g)(b+c+f+g)(d+e+f+g) = (a+b+c+d+e) \cdot$   
 $(a+b+c+f)(a+d+e+g)(b+c+f+g)(d+e+f+g) =$   
 $(a+b+c+df+ef)(a+d+e+g)(b+c+f+g)(d+e+f+g) =$   
 $(a+b+c+df+ef)(d+e+g+af)(b+c+f+g) = [(b+c)+(a+df+ef)(f+g)](d+e+g+af) =$   
 $[b+c+af+df+ag+dfg+efg](d+e+g+af) = [b+c+af+df+ef+ag](d+e+g+af) =$

$$bd+cd+adf+df+def+adg+be+ce+ae+ef+ef+aeg+bg+cg+afg+dfg+efg+ag+abf + acf + af + adf + aef + afg = bd + cd + df + ag + ef + be + ce + af + bg + cg.$$

### Section 15.4

1. (The second Distributive Law). Let  $x = 2^{k_1}3^{k_2}5^{k_3}$ ,  $y = 2^{m_1}3^{m_2}5^{m_3}$ ,  $z = 2^{n_1}3^{n_2}5^{n_3}$  where for  $1 \leq i \leq 3$ ,  $0 \leq k_i, m_i, n_i \leq 1$ .

$\gcd(y, z) = 2^{s_1}3^{s_2}5^{s_3}$  where  $s_i = \min\{m_i, n_i\}$ ,  $1 \leq i \leq 3$ .  $\text{lcm}(x, \gcd(y, z)) = 2^{t_1}3^{t_2}5^{t_3}$  where  $t_i = \max\{k_i, s_i\}$ ,  $1 \leq i \leq 3$ . Also,  $\text{lcm}(x, y) = 2^{u_1}3^{u_2}5^{u_3}$ ,  $\text{lcm}(x, z) = 2^{v_1}3^{v_2}5^{v_3}$  where  $u_i = \max\{k_i, m_i\}$ ,  $v_i = \max\{k_i, n_i\}$ ,  $1 \leq i \leq 3$ , and  $\gcd(\text{lcm}(x, y), \text{lcm}(x, z)) = 2^{w_1}3^{w_2}5^{w_3}$  where  $w_i = \min\{u_i, v_i\}$ ,  $1 \leq i \leq 3$ . To prove that  $\text{lcm}(x, \gcd(y, z)) = \gcd(\text{lcm}(x, y), \text{lcm}(x, z))$  we need to show that  $t_i = w_i$ ,  $1 \leq i \leq 3$ . If  $k_i = 0$ , then  $t_i = s_i$ ,  $u_i = m_i$ ,  $v_i = n_i$  and  $w_i = \min\{u_i, v_i\} = \min\{m_i, n_i\} = s_i = t_i$ . If  $k_i = 1$ , then  $t_i = 1 = u_i = v_i = w_i$ .

(The Identity Laws)  $x + 0 =$  the lcm of  $x$  and 1 (the zero element)  $= x$ ;  $x \cdot 1 =$  the gcd of  $x$  and 30 (the one element)  $= x$ , since  $x$  is a divisor of 30.

(The Inverse Laws)  $x + \bar{x} =$  the lcm of  $x$  and  $30/x = 30$  (the one element of this Boolean algebra);  $x\bar{x} =$  the gcd of  $x$  and  $30/x = 1$  (the zero element of the Boolean algebra).

2. (b)'

$$\begin{aligned} x + xy &= x \cdot 1 + xy && \text{Def. 15.5 (c)'} \\ &= x(1 + y) && \text{Def. 15.5 (b)} \\ &= x \cdot 1 && \text{Th. 15.3 (a)'} \\ &= x && \text{Def. 15.5 (c)'} \end{aligned}$$

(b) Follows by duality.

(h)  $\bar{0} = \overline{x\bar{x}} = \bar{x} + x = 1$

(h)' Follows by duality.

(i)  $x\bar{y} = 0 \implies x = x \cdot 1 = x(y + \bar{y}) = xy + x\bar{y} = xy + 0 = xy$   
 $xy = x \implies 0 = x\bar{x} = x(\overline{xy}) = x(\bar{x} + \bar{y}) = x\bar{x} + x\bar{y} = 0 + x\bar{y} = x\bar{y}$

(i)' Follows by duality.

3. (a) 30      (b) 30      (c) 1      (d) 21      (e) 30      (f) 70

4. (a)  $x + y = xy + y = y(x + 1) = y \cdot 1 = y$

(b)  $x \leq y \implies x + y = y \implies \overline{x + y} = \bar{y} \implies \bar{x} \bar{y} = \bar{y} \implies \bar{y} \leq \bar{x}$ .

5. (a)  $w \leq 0 \implies w \cdot 0 = w$ . But  $w \cdot 0 = 0$ , by part (a) of Theorem 15.3.

(b)  $1 \leq x \implies 1 \cdot x = 1$ , and  $1 \cdot x = x$  from our definition of a Boolean algebra.

(c)  $y \leq z \implies yz = y$ , and  $y \leq \bar{z} \implies y\bar{z} = y$ . Therefore  $y = yz = (y\bar{z})z = y(\bar{z}z) = y \cdot 0 = 0$ .

6. Proof:
- (a)  $w \leq x \Rightarrow wx = w$ , and  $y \leq z \Rightarrow yz = y$ . Consequently,  $(wx)(yz) = wy$ , and we find that  $wy = (wx)(yz) = (wy)(xz) \Rightarrow wy \leq xz$ .
- (b) As in part (a),  $w \leq x \Rightarrow wx = w$ , and  $y \leq z \Rightarrow yz = y$ . Therefore,  $(w + y)(x + z) = wx + wz + yx + yz = (w + wz) + (y + yx) = w + y$ , by the Absorption Law (Theorem 15.3 (b)'). But  $(w + y)(x + z) = w + y \Rightarrow w + y \leq x + z$ .
7.  $x \leq y \iff xy = x$ . The dual of  $xy = x$  is  $x + y = x$ .
- $x + y = x \implies xy = (x + y)y = xy + y = y(x + 1) = y \cdot 1 = y$ , and  $xy = y \iff y \leq x$ . Consequently, the dual of  $x \leq y$  is  $y \leq x$ .
8.  $2^n$
9. From Theorem 15.5(a), with  $x_1, x_2$  distinct atoms, if  $x_1, x_2 \neq 0$ , then  $x_1 = x_1x_2 = x_2x_1 = x_2$ , a contradiction.
10. If 0 and 0' are both zero elements of  $B$  then  $0 = 0 + 0' = 0'$ . In a similar way, if 1 and 1' are both one elements of  $B$  then  $1 = 1 \cdot 1' = 1'$ .
11. (d) Since  $x$  is an atom of  $B_1$ ,  $x \neq 0$  so  $f(x) \neq 0$ . Let  $y \in B_2$  with  $0 \neq y$  and  $y \leq f(x)$ . With  $f$  an isomorphism there exists  $z \in B_1$  with  $f(z) = y$ . Also,  $f^{-1} : B_2 \rightarrow B_1$  is an isomorphism so  $f(z) \leq f(x) \implies z \leq x$ . With  $x$  an atom and  $0 < z \leq x$  we have  $z = x$  so  $f(z) = y = f(x)$ , and  $f(x)$  is an atom.
12. (a)  $f(35) = f(5 + 7) = f(5) \cup f(7) = \{c\} \cup \{d\} = \{c, d\}$   
 $f(110) = f(2 + 5 + 11) = \{a, c, e\}$   
 $f(210) = f(2 + 3 + 5 + 7) = \{a, b, c, d\}$   
 $f(330) = f(2 + 3 + 5 + 11) = \{a, b, c, e\}$
- (b) 5! (Since any isomorphism of finite Boolean algebras must correspond atoms.)
13. (a)  $f(xy) = \overline{f(\overline{x + \overline{y}})} = \overline{f(\overline{x + \overline{y}})} = \overline{f(\overline{x}) + f(\overline{y})} = \overline{f(\overline{x})} \cdot \overline{f(\overline{y})} = f(\overline{\overline{x}}) \cdot f(\overline{\overline{y}}) = f(x) \cdot f(y)$ .
- (b) Let  $B_1, B_2$  be Boolean algebras with  $f : B_1 \rightarrow B_2$  one-to-one and onto. Then  $f$  is an isomorphism if  $f(\overline{x}) = \overline{f(x)}$  and  $f(xy) = f(x)f(y)$  for all  $x, y \in B_1$ . [Follows from part (a) by duality.]
14. Let  $S \subseteq \mathcal{U}$ . If  $S = \emptyset$ , then  $f(0) = S$ . If  $S \neq \emptyset$ , then let  $x = \sum_{i=1}^n c_i x_i$  where  $c_i = 1$  if  $i \in S$  and  $c_i = 0$  if  $i \notin S$ . Then  $f(x) = S$ . Hence  $f$  is onto. Since  $|B| = |\mathcal{P}(\mathcal{U})| = 2^n$ , it follows from Theorem 5.11 that  $f$  is also one-to-one.
15. For each  $1 \leq i \leq n$ ,  $(x_1 + x_2 + \dots + x_n)x_i = x_1x_i + x_2x_i + \dots + x_{i-1}x_i + x_ix_i + x_{i+1}x_i + \dots + x_nx_i = 0 + 0 + \dots + 0 + x_i + 0 + \dots + 0 = x_i$ , by part (b) of Theorem 15.5. Consequently, it follows from Theorem 15.7 that  $(x_1 + x_2 + \dots + x_n)x = x$  for all  $x \in B$ . Since the one element is unique (from Exercise 10) we conclude that  $1 = x_1 + x_2 + \dots + x_n$ .

## Supplementary Exercises

1. (a) When  $n = 2$ ,  $x_1 + x_2$  denotes the Boolean sum of  $x_1$  and  $x_2$ . For  $n \geq 2$ , we define  $x_1 + x_2 + \dots + x_n + x_{n+1}$  recursively by  $(x_1 + x_2 + \dots + x_n) + x_{n+1}$ . [A similar definition can be given for the Boolean product.]

For  $n = 2$ ,  $\overline{x_1 + x_2} = \bar{x}_1 \bar{x}_2$  is true, for this is one of the DeMorgan Laws. Assume the result for  $n = k (\geq 2)$  and consider the case of  $n = k + 1$ .  $\overline{(x_1 + x_2 + \dots + x_k + x_{k+1})} = \overline{(x_1 + x_2 + \dots + x_k) + x_{k+1}} = \overline{(x_1 + x_2 + \dots + x_k)} \cdot \bar{x}_{k+1} = \bar{x}_1 \bar{x}_2 \cdots \bar{x}_k \bar{x}_{k+1}$ . Consequently, the result follows for all  $n \geq 2$  by the Principle of Mathematical Induction.

(b) Follows from part (a) by duality.

2.  $y = 4, z = 7; x = 16$  or  $25$

3. Let  $v, w, x, y, z$  indicate that Eileen invites Margaret, Joan, Kathleen, Nettie, and Cathy, respectively. The conditions in (a) – (e) can then be expressed as

(a)  $(v \rightarrow w) \iff (\bar{v} + w)$

(b)  $(x \rightarrow vy) \iff (\bar{x} + vy)$

(c)  $\bar{w}z + w\bar{z}$

(d)  $yz + \bar{y}\bar{z}$

(e)  $x + y + xy \iff x + y$

$$(\bar{v} + w)(\bar{x} + vy)(\bar{w}z + w\bar{z})(yz + \bar{y}\bar{z})(x + y) \iff (\bar{v} + w)(\bar{x}y + vy)(\bar{w}z + w\bar{z})(yz + \bar{y}\bar{z})$$

$$\iff (\bar{v} + w)(\bar{x}y + vy)(\bar{w}yz + w\bar{y}\bar{z}) \iff (\bar{v} + w)(\bar{w}\bar{x}yz + \bar{w}vyz) \iff \bar{v}\bar{w}\bar{x}yz$$

Consequently, the only way Eileen can have her party and satisfy conditions (a) – (e) is to invite only Nettie and Cathy out of this group of five of her friends.

4.  $h = \sum m(2, 4, 6, 8) + d(0, 10, 12, 14)$

5. Proof: If  $x \leq z$  and  $y \leq z$  then from Exercise 6(b) of Section 15.4 we have  $x + y \leq z + z$ . And by the idempotent law we have  $z + z = z$ .

Conversely, suppose that  $x + y \leq z$ . We find that  $x \leq x + y$ , because  $x(x + y) = x + xy$  (by the idempotent law)  $= x$  (by the absorption law). Since  $x \leq x + y$  and  $x + y \leq z$  we have  $x \leq z$ , because a partial order is transitive. [The proof that  $y \leq z$  follows in a similar way.]

6. Statement: Let  $\mathcal{B}$  be a Boolean algebra partially ordered by  $\leq$ . If  $x, y, z \in \mathcal{B}$ , then  $xy \geq z$  if and only if  $x \geq z$  and  $y \geq z$ .

Proof: If  $x \geq z$  and  $y \geq z$ , then from Exercise 6(a) of Section 15.4 we have  $xy \geq zz$ . The result now follows from the idempotent law because  $zz = z$ .

Conversely, suppose that  $xy \geq z$ . We claim that  $x \geq xy$ . This follows because  $(xy)x = x(yx) = x(xy) = (xx)y = xy$ . Since  $\leq$  is transitive,  $x \geq xy$  and  $xy \geq z \Rightarrow x \geq z$ . [The proof that  $y \geq z$  follows in a similar manner.]

7. Proof:

(a)  $x \leq y \Rightarrow x + \bar{x} \leq y + \bar{x} \Rightarrow 1 \leq y + \bar{x} \Rightarrow y + \bar{x} = \bar{x} + y = 1$ . Conversely,  $\bar{x} + y = 1 \Rightarrow x(\bar{x} + y) = x \cdot 1 \Rightarrow x\bar{x} (= 0) + xy = x \Rightarrow xy = x \Rightarrow x \leq y$ .

(b)  $x \leq \bar{y} \Rightarrow x\bar{y} = x \Rightarrow xy = (x\bar{y})y = x(\bar{y}y) = x \cdot 0 = 0$ . Conversely,  $xy = 0 \Rightarrow x = x \cdot 1 =$

$$x(y + \bar{y}) = xy + x\bar{y} = x\bar{y}, \text{ and } x = x\bar{y} \Rightarrow x \leq \bar{y}.$$

8. Proof: If  $x = y$  then  $x\bar{y} + \bar{x}y = x\bar{x} + \bar{x}x = 0 + 0 = 0$ .

Conversely, suppose that  $x\bar{y} + \bar{x}y = 0$ . Then

$$\begin{aligned} x = x + 0 &= x + (x\bar{y} + \bar{x}y) \\ &= (x + x\bar{y}) + \bar{x}y, \text{ by the Associative Law of } + \\ &= x + x\bar{y}, \text{ by the Absorption Law (Theorem 15.3 (b)')} \\ &= (x + \bar{x})(x + y), \text{ by the Distributive Law of } + \text{ over } \cdot \\ &= 1(x + y) \\ &= x + y \\ &= (x + y)1 \\ &= (x + y)(\bar{y} + y) \\ &= x\bar{y} + y, \text{ by the Distributive Law of } + \text{ over } \cdot \\ &\quad \text{(and the Commutative Law of } +) \\ &= x\bar{y} + (\bar{x}y + y), \text{ by the Absorption Law (Theorem 15.3 (b)')} \\ &= (x\bar{y} + \bar{x}y) + y, \text{ by the Associative Law of } + \\ &= 0 + y = y. \end{aligned}$$

9. (a)

$wx \setminus yz$	00	01	11	10
00	1	1	1	1
01			1	1
11			1	1
10				

$$f(w, x, y, z) = \bar{w}\bar{x} + xy$$

(b)

$wx \setminus yz$	00	01	11	10
00	1	1	1	1
01		1	1	
11	1	1	1	
10	1			

$wx \setminus yz$	00	01	11	10
00	1			
01		1	1	
11		1	1	
10				1

$$g(v, w, x, y, z) = \bar{v}\bar{w}yz + xz + w\bar{y}\bar{z} + \bar{x}\bar{y}\bar{z}$$

10.

$$(a) \quad g(a, b, c, e) = \bar{a}\bar{b}\bar{c}e (1) + \bar{a}\bar{b}c\bar{e} (2) + \bar{a}b\bar{c}\bar{e} (4) + a\bar{b}\bar{c}\bar{e} (8)$$

(b)

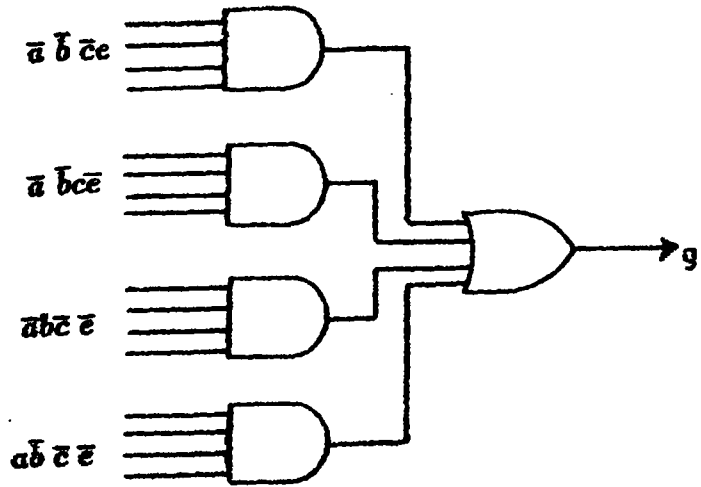

(c)  $g(a, b, c, e) = \sum m(1, 2, 4, 8) + d(10, 11, 12, 13, 14, 15)$

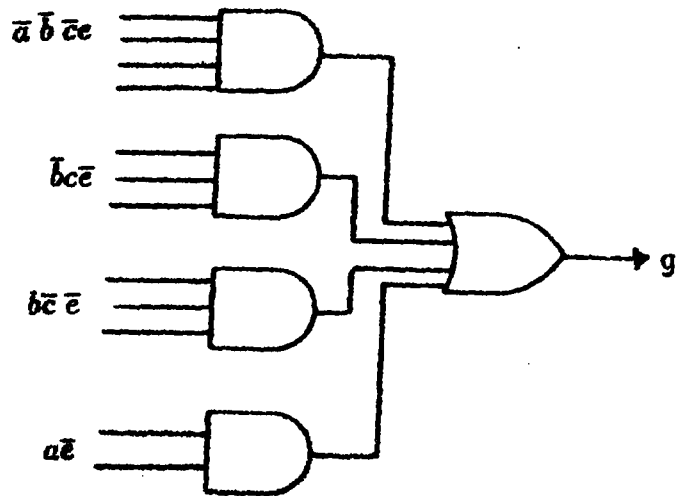
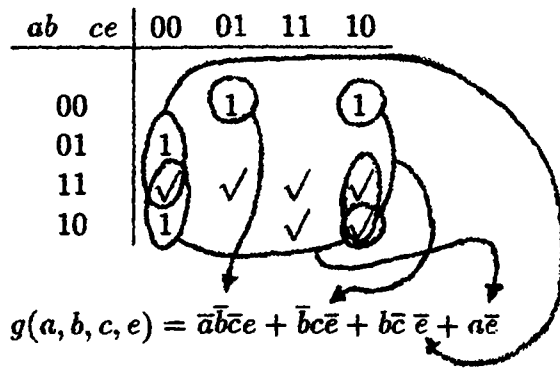

11. (a)  $2^{(2^n-1)}$

(b)  $2^4; 2^{n+1}$

12.  $4!$

13. (a)  $60 = 2^2 \cdot 3 \cdot 5$  so there are 12 divisors of 60. Since 12 is not a power of 2 these divisors cannot yield a Boolean algebra.
- (b)  $120 = 2^3 \cdot 3 \cdot 5$  and there are 16 divisors of 60. Let  $x = 4$ . Then  $\bar{x} = 120/4 = 30$  and  $x \cdot \bar{x} = \text{gcd of } x \text{ and } \bar{x} = \text{gcd}(4, 30) = 2$ , not 1. Hence although  $16 = 2^4$  the divisors of 120 do not yield a Boolean algebra.
14. If  $c \leq a$ , then  $ac = c$ , so  $ab+c = ab+ac = a(b+c)$ . Conversely, if  $ab+c = a(b+c) = ab+ac$ , then  $ac = ac+0 = ac+(ab+\overline{ab}) = (ab+ac)+\overline{ab} = (ab+c)+\overline{ab} = c+(ab+\overline{ab}) = c$ , and  $ac = c \implies c \leq a$ .

CHAPTER 16  
GROUPS, CODING THEORY, AND  
POLYA'S METHOD OF ENUMERATION

**Section 16.1**

1. (a) Yes. The identity is 1 and each element is its own inverse.  
 (b) No. The set is not closed under addition and there is no identity.  
 (c) No. The set is not closed under addition.  
 (d) Yes. The identity is 0; the inverse of  $10n$  is  $10(-n)$  or  $-10n$ .  
 (e) Yes. The identity is  $1_A$  and the inverse of  $g : A \rightarrow A$  is  $g^{-1} : A \rightarrow A$ .  
 (f) Yes. The identity is 0; the inverse of  $a/(2^n)$  is  $(-a)/(2^n)$ .
  
2. (c)  $ab = ac \implies a^{-1}(ab) = a^{-1}(ac) \implies (a^{-1}a)b = (a^{-1}a)c \implies eb = ec \implies b = c$   
 (d)  $ba = ca \implies (ba)a^{-1} = (ca)a^{-1} \implies b(aa^{-1}) = c(aa^{-1}) \implies be = ce \implies b = c$
  
3. Subtraction is not an associative (closed) binary operation - e.g.,  $(3 - 2) - 4 = -3 \neq 5 = 3 - (2 - 4)$ .
  
4. (i) For all  $a, b, c \in G$ ,  
 $(a \circ b) \circ c = (a + b + ab) \circ c = a + b + ab + c + (a + b + ab)c = a + b + ab + c + ac + bc + abc$   
 $a \circ (b \circ c) = a \circ (b + c + bc) = a + b + c + bc + a(b + c + bc) = a + b + c + bc + ab + ac + abc$ .  
 Since  $(a \circ b) \circ c = a \circ (b \circ c)$  for all  $a, b, c \in G$  it follows that the (closed) binary operation is associative.  
 (ii) If  $x, y \in G$ ; then  $x \circ y = x + y + xy = y + x + yx = y \circ x$ , so the (closed) binary operation is also commutative.  
 (iii) Can we find  $a \in G$  so that  $x = x \circ a$  for all  $x \in G$ ?  
 $x = x \circ a \implies x = x + a + xa \implies 0 = a(1 + x) \implies a = 0$ , because  $x$  is arbitrary, so 0 is the identity for this (closed) binary operation.  
 (iv) For  $x \in G$ , can we find  $y \in G$  with  $x \circ y = 0$ ? Here  $0 = x \circ y = x + y + xy \implies -x = y(1 + x) \implies y = -x(1 + x)^{-1}$ , so the inverse of  $x$  is  $-x(1 + x)^{-1}$ .  
 It follows from (i) - (iv) that  $(G, \circ)$  is an abelian group.
  
5. Since  $x, y \in \mathbf{Z} \implies x + y + 1 \in \mathbf{Z}$ , the operation is a (closed) binary operation (or  $\mathbf{Z}$  is closed under  $\circ$ ). For all  $w, x, y \in \mathbf{Z}$ ,  $w \circ (x \circ y) = w \circ (x + y + 1) = w + (x + y + 1) + 1 = (w + x + 1) + y + 1 = (w \circ x) \circ y$ , so the (closed) binary operation is associative. Furthermore,  $x \circ y = x + y + 1 = y + x + 1 = y \circ x$ , for all  $x, y \in \mathbf{Z}$ , so  $\circ$  is also commutative. If  $x \in \mathbf{Z}$  then  $x \circ (-1) = x + (-1) + 1 = x [= (-1) \circ x]$ , so  $-1$  is the identity element for  $\circ$ . And finally, for

each  $x \in \mathbf{Z}$ , we have  $-x-2 \in \mathbf{Z}$  and  $x \circ (-x-2) = x + (-x-2) + 1 = -1 [= (-x-2) + x]$ , so  $-x-2$  is the inverse for  $x$  under  $\circ$ . Consequently,  $(\mathbf{Z}, \circ)$  is an abelian group.

6. (i) For all  $(a, b), (u, v), (x, y) \in S$  we have  
 $(a, b) \circ [(u, v) \circ (x, y)] = (a, b) \circ (ux, vx + y) = (aux, bux + vx + y)$   
 $[(a, b) \circ (u, v)] \circ (x, y) = (au, bu + v) \circ (x, y) = (aux, (bu + v)x + y) = (aux, bux + vx + y)$ ,  
 so the given (closed) binary operation is associative.  
 (ii) To find the identity element we need  $(a, b) \in S$  such that  $(a, b) \circ (u, v) = (u, v) = (u, v) \circ (a, b)$  for all  $(u, v) \in S$ .  
 $(u, v) = (u, v) \circ (a, b) = (ua, va + b) \implies u = ua$  and  $v = va + b \implies a = 1$  and  $b = 0$ .  
 In addition,  $(1, 0) \circ (u, v) = (1 \cdot u, 0 \cdot u + v) = (u, v)$ , so  $(1, 0)$  is the identity for this (closed) binary operation.  
 (iii) Given  $(a, b) \in S$  can we find  $(c, d) \in S$  so that  $(a, b) \circ (c, d) = (c, d) \circ (a, b) = (1, 0)$ ?  
 $(1, 0) = (a, b) \circ (c, d) = (ac, bc + d) \implies 1 = ac, 0 = bc + d \implies c = a^{-1}, d = -ba^{-1}$ .  
 Since  $(a^{-1}, -ba^{-1}) \circ (a, b) = (a^{-1}a, (-ba^{-1})a + b) = (1, 0)$ ,  $(a^{-1}, -ba^{-1})$  is the inverse of  $(a, b)$  for this (closed) binary operation.  
 From (i)-(iii) it follows that  $(S, \circ)$  is a group. Since  $(1, 2), (2, 3) \in S$  and  $(1, 2) \circ (2, 3) = (2, 7)$ , while  $(2, 3) \circ (1, 2) = (2, 5)$ , this group is nonabelian.

7.  $U_{20} = \{1, 3, 7, 9, 11, 13, 17, 19\}$

$U_{24} = \{1, 5, 7, 11, 13, 17, 19, 23\}$

8. Proof: Suppose that  $G$  is abelian and that  $a, b \in G$ . Then  $(ab)^2 = (ab)(ab) = a(ba)b = a(ab)b = (aa)(bb) = a^2b^2$ , by using the associative property for a group and the fact that this group is abelian.

Conversely, suppose that  $G$  is a group where  $(ab)^2 = a^2b^2$  for all  $a, b \in G$ . If  $x, y \in G$ , then  $(xy)^2 = x^2y^2 \implies (xy)(xy) = x^2y^2 \implies x(yx)y = x(xy^2) \implies (yx)y = xy^2$  (by Theorem 16.1 (c))  $\implies (yx)y = (xy)y \implies yx = xy$  (by Theorem 16.1 (d)). Therefore, the group  $G$  is abelian.

9. (a) The result follows from Theorem 16.1(b) since both  $(a^{-1})^{-1}$  and  $a$  are inverses of  $a^{-1}$ .

(b)  $(b^{-1}a^{-1})(ab) = b^{-1}(a^{-1}a)b = b^{-1}(e)b = b^{-1}b = e$  and  $(ab)(b^{-1}a^{-1}) = a(bb^{-1})a^{-1} = a(e)a^{-1} = aa^{-1} = e$ . So  $b^{-1}a^{-1}$  is an inverse of  $ab$ , and by Theorem 16.1(b),  $(ab)^{-1} = b^{-1}a^{-1}$ .

10.  $G$  abelian  $\implies a^{-1}b^{-1} = b^{-1}a^{-1}$ . By Exercise 9(b),  $b^{-1}a^{-1} = (ab)^{-1}$ , so  $G$  abelian  $\implies a^{-1}b^{-1} = (ab)^{-1}$ . Conversely, if  $a, b \in G$ , then  $a^{-1}b^{-1} = (ab)^{-1} \implies a^{-1}b^{-1} = b^{-1}a^{-1} \implies ba^{-1}b^{-1} = a^{-1} \implies ba^{-1} = a^{-1}b \implies b = a^{-1}ba \implies ab = ba \implies G$  is abelian.

11. (a)  $\{0\}; \{0, 6\}; \{0, 4, 8\}; \{0, 3, 6, 9\}; \{0, 2, 4, 6, 8, 10\}; \mathbf{Z}_{12}$ .

(b)  $\{1\}; \{1, 10\}; \{1, 3, 4, 5, 9\}; \mathbf{Z}_{11}^*$ .

(c)  $\{\pi_0\}; \{\pi_0, \pi_1, \pi_2\}; \{\pi_0, r_1\}; \{\pi_0, r_2\}; \{\pi_0, r_3\}; S_3$

12. (a) There are eight rigid motions for a square:  $\pi_0, \pi_1, \pi_2, \pi_3$ , where  $\pi_i$  is the

counterclockwise rotation through  $i(90^\circ)$ ,  $0 \leq i \leq 3$ ;  $r_1$  is the reflection in the vertical;  $r_2$  is the reflection in the horizontal;  $r_3$  the reflection in the diagonal from lower left to upper right; and  $r_4$  the reflection in the diagonal from upper left to lower right.

(b)

$o$	$\pi_0$	$\pi_1$	$\pi_2$	$\pi_3$	$r_1$	$r_2$	$r_3$	$r_4$
$\pi_0$	$\pi_0$	$\pi_1$	$\pi_2$	$\pi_3$	$r_1$	$r_2$	$r_3$	$r_4$
$\pi_1$	$\pi_1$	$\pi_2$	$\pi_3$	$\pi_0$	$r_3$	$r_4$	$r_2$	$r_1$
$\pi_2$	$\pi_2$	$\pi_3$	$\pi_0$	$\pi_1$	$r_2$	$r_1$	$r_4$	$r_3$
$\pi_3$	$\pi_3$	$\pi_0$	$\pi_1$	$\pi_2$	$r_4$	$r_3$	$r_1$	$r_2$
$r_1$	$r_1$	$r_4$	$r_2$	$r_3$	$\pi_0$	$\pi_2$	$\pi_3$	$\pi_1$
$r_2$	$r_2$	$r_3$	$r_1$	$r_4$	$\pi_2$	$\pi_0$	$\pi_1$	$\pi_3$
$r_3$	$r_3$	$r_1$	$r_4$	$r_2$	$\pi_1$	$\pi_3$	$\pi_0$	$\pi_2$
$r_4$	$r_4$	$r_2$	$r_3$	$r_1$	$\pi_3$	$\pi_1$	$\pi_2$	$\pi_0$

$\pi_0$  is the group identity.

The inverse of each reflection is the same reflection. The inverse of the rotation  $\pi_1$  is the rotation  $\pi_3$ , and conversely. The inverse of the rotation  $\pi_2$  is itself. Also, the inverse of  $\pi_0$  is  $\pi_0$ .

13. (a) There are 10: five rotations through  $i(72^\circ)$ ,  $0 \leq i \leq 4$ , and five reflections about lines containing a vertex and the midpoint of the opposite side.

(b) For a regular  $n$ -gon ( $n \geq 3$ ) there are  $2n$  rigid motions. There are the  $n$  rotations through  $i(360^\circ/n)$ ,  $0 \leq i \leq n-1$ . There are  $n$  reflections. For  $n$  odd each reflection is about a line through a vertex and the midpoint of the opposite side. For  $n$  even, there are  $n/2$  reflections about lines through opposite vertices and  $n/2$  reflections about lines through the midpoints of opposite sides.

14.

$$\alpha\beta = \begin{pmatrix} 12345 \\ 15234 \end{pmatrix}, \quad \beta\alpha = \begin{pmatrix} 12345 \\ 32514 \end{pmatrix}, \quad \alpha^3 = \begin{pmatrix} 12345 \\ 12345 \end{pmatrix},$$

$$\beta^4 = \begin{pmatrix} 12345 \\ 12534 \end{pmatrix}, \quad \alpha^{-1} = \begin{pmatrix} 12345 \\ 31245 \end{pmatrix}, \quad \beta^{-1} = \begin{pmatrix} 12345 \\ 21453 \end{pmatrix},$$

$$(\alpha\beta)^{-1} = \begin{pmatrix} 12345 \\ 13452 \end{pmatrix}, \quad (\beta\alpha)^{-1} = \begin{pmatrix} 12345 \\ 42163 \end{pmatrix}, \quad \beta^{-1}\alpha^{-1} = \begin{pmatrix} 12345 \\ 13452 \end{pmatrix}.$$

15. Since  $eg = ge$  for all  $g \in G$ , it follows that  $e \in H$  and  $H \neq \emptyset$ . If  $x, y \in H$ , then  $xg = gx$  and  $yg = gy$  for all  $g \in G$ . Consequently,  $(xy)g = x(yg) = x(gy) = (xg)y = (gx)y = g(xy)$  for all  $g \in G$ , and we have  $xy \in H$ . Finally, for all  $x \in H$  and  $g \in G$ ,  $xg^{-1} = g^{-1}x$ . So  $(xg^{-1})^{-1} = (g^{-1}x)^{-1}$ , or  $gx^{-1} = x^{-1}g$ , and  $x^{-1} \in H$ . Therefore  $H$  is a subgroup of  $G$ .

16. (a)

$$\begin{aligned}\omega &= (1/\sqrt{2})(1+i) & \omega^2 &= i \\ \omega^3 &= (1/\sqrt{2})(-1+i) & \omega^4 &= -1 \\ \omega^5 &= (1/\sqrt{2})(-1-i) & \omega^6 &= -i \\ \omega^7 &= (1/\sqrt{2})(1-i) & \omega^8 &= 1\end{aligned}$$

(b) Let  $S = \{\omega^n | 1 \leq n \leq 8\}$ . Then for all  $1 \leq j, k \leq 8$ ,  $\omega^j \cdot \omega^k = \omega^m$ , where  $m \equiv j+k \pmod{8}$  and  $1 \leq m \leq 8$ . So  $S$  is closed under the binary operation of multiplication, which is commutative and associative for all complex numbers - so, in particular, the complex numbers is  $S$ .

The element  $\omega^8 = 1$  is the identity element and, for all  $1 \leq n \leq 7$ , we have  $(\omega^n)^{-1} = \omega^{8-n}$ , so every element of  $S$  has a multiplicative inverse in  $S$ .

Consequently,  $S$  is an abelian group under multiplication.

17. (a) Let  $(g_1, h_1), (g_2, h_2) \in G \times H$ . Then  $(g_1, h_1) \cdot (g_2, h_2) = (g_1 \circ g_2, h_1 * h_2)$ , where  $g_1 \circ g_2 \in G$ ,  $h_1 * h_2 \in H$ , since  $(G, \circ)$  and  $(H, *)$  are closed. Hence  $G \times H$  is closed. For  $(g_1, h_1), (g_2, h_2), (g_3, h_3) \in G \times H$ ,  $[(g_1, h_1) \cdot (g_2, h_2)] \cdot (g_3, h_3) = (g_1 \circ g_2, h_1 * h_2) \cdot (g_3, h_3) = ((g_1 \circ g_2) \circ g_3, (h_1 * h_2) * h_3) = (g_1 \circ (g_2 \circ g_3), h_1 * (h_2 * h_3)) = (g_1, h_1) \cdot (g_2 \circ g_3, h_2 * h_3) = (g_1, h_1) \cdot [(g_2, h_2) \cdot (g_3, h_3)]$ , since the operations in  $G$  and  $H$  are associative. Hence,  $G \times H$  is associative under  $\cdot$ .

Let  $e_G, e_H$  denote the identities for  $G, H$ , respectively. Then  $(e_G, e_H)$  is the identity in  $G \times H$ .

Finally, let  $(g, h) \in G \times H$ . If  $g^{-1}$  is the inverse of  $g$  in  $G$  and  $h^{-1}$  is the inverse of  $h$  in  $H$ , then  $(g^{-1}, h^{-1})$  is the inverse of  $(g, h)$  in  $G \times H$ .

(b) (i) 216

(ii)  $H_1 = \{(x, 0, 0) | x \in \mathbf{Z}_6\}$  is a subgroup of order 6;  $H_2 = \{(x, y, 0) | x, y \in \mathbf{Z}_6, y = 0, 3\}$  is a subgroup of order 12;  $H_3 = \{(x, y, 0) | x, y \in \mathbf{Z}_6\}$  has order 36.

(iii)  $-(2, 3, 4) = (4, 3, 2)$ ;  $-(4, 0, 2) = (2, 0, 4)$ ;  $-(5, 1, 2) = (1, 5, 4)$ .

18. (a) Since  $e \in H$  and  $e \in K$ , we have  $e \in H \cap K$  and  $H \cap K \neq \emptyset$ . Now let  $x, y \in H \cap K$ .  $x, y \in H \cap K \implies x, y \in H$  and  $x, y \in K \implies xy \in H$  and  $xy \in K$  (since  $H, K$  are subgroups)  $\implies xy \in H \cap K$

$x \in H \cap K \implies x \in H$  and  $x \in K \implies x^{-1} \in H$  and  $x^{-1} \in K$  (because  $H, K$  are subgroups)  $\implies x^{-1} \in H \cap K$ .

Therefore by Theorem 16.2 we have  $H \cap K$  a subgroup of  $G$ .

(b) Let  $G$  be the group of rigid motions of the equilateral triangle as given in Example 16.7. Let  $H = \{\pi_0, \pi_1, \pi_2\}$  and  $K = \{\pi_0, r_1\}$ . Then  $H, K$  are subgroups of  $G$ . Here  $H \cup K = \{\pi_0, \pi_1, \pi_2, r_1\}$  and, since  $r_1\pi_1 = r_2 \notin H \cup K$ , it follows that  $H \cup K$  is not a subgroup of  $G$ .

19. (a)  $x = 1, x = 4$

(b)  $x = 1, x = 10$

(c)  $x = x^{-1} \implies x^2 \equiv 1 \pmod{p} \implies x^2 - 1 \equiv 0 \pmod{p} \implies (x-1)(x+1) \equiv 0 \pmod{p} \implies x-1 \equiv 0 \pmod{p}$  or  $x+1 \equiv 0 \pmod{p} \implies x \equiv 1 \pmod{p}$  or  $x \equiv -1 \equiv p-1$

(mod  $p$ ).

(d) The result is true for  $p = 2$ , since  $(2 - 1)! = 1! \equiv -1 \pmod{2}$ . For  $p \geq 3$ , consider the elements  $1, 2, \dots, p - 1$  in  $(\mathbb{Z}_p^*, \cdot)$ . The elements  $2, 3, \dots, p - 2$  yield  $(p - 3)/2$  pairs of the form  $x, x^{-1}$ . [For example, when  $p = 11$  we find that  $2, 3, 4, \dots, 9$  yield the four pairs  $2, 6; 3, 4; 5, 9; 7, 8$ .] Consequently,  $(p - 1)! \equiv (1)(1)^{(p-3)/2}(p - 1) \equiv p - 1 \equiv -1 \pmod{p}$ .

20. (a) In  $(U_8, \cdot)$  we have  $3^2 = 1$ , so  $3 = 3^{-1}$ , and  $5^2 = 1$ , so  $5 = 5^{-1}$ .  
(b) In  $(U_{16}, \cdot)$  we have  $7^2 = 1$ , so  $7 = 7^{-1}$ , and  $9^2 = 1$ , so  $9 = 9^{-1}$ .  
(c) Let  $x = (2^{k-1} - 1)$  in  $(U_{2^k}, \cdot)$ . One finds that  $x^2 = (2^{k-1} - 1)(2^{k-1} - 1) = 2^{2k-2} - 2 \cdot 2^{k-1} + 1 = (2^k)(2^{k-2}) - 2k + 1 = 0(2^{k-2}) - 0 + 1 = 1$ , so  $x = x^{-1}$ . This is also true for  $x = (2^{k-1} + 1)$ .

## Section 16.2

1. (c) If  $n = 0$ , the result follows from part (a) of Theorem 16.5. So consider  $n \in \mathbb{Z}^+$ .

For  $n = 1$ ,  $f(a^n) = f(a^1) = f(a) = [f(a)]^1 = [f(a)]^n$ , so the result follows for  $n = 1$ . Now assume the result true for  $n = k$  ( $\geq 1$ ) and consider  $n = k + 1$ . Then  $f(a^n) = f(a^{k+1}) = f(a^k \cdot a) = f(a^k) \cdot f(a) = [f(a)]^k \cdot f(a) = [f(a)]^{k+1} = [f(a)]^n$ . So by the Principle of Mathematical Induction, the result is true for all  $n \geq 1$ .

For  $n \geq 1$ , we have  $a^{-n} = (a^{-1})^n$  - as defined in the material following Theorem 16.1. So  $f(a^{-n}) = f[(a^{-1})^n] = [f(a^{-1})]^n$  by our previous work. Then  $[f(a^{-1})]^n = [(f(a))^{-1}]^n = [f(a)]^{-n}$  - by part (b) of Theorem 16.1. Hence  $f(a^{-n}) = [f(a)]^{-n}$ .

Consequently,  $f(a^n) = [f(a)]^n$ , for all  $a \in G$  and all  $n \in \mathbb{Z}$ .

2. (a)

$$A^2 = \begin{bmatrix} -1 & 0 \\ 0 & -1 \end{bmatrix}, \quad A^3 = \begin{bmatrix} 0 & -1 \\ 1 & 0 \end{bmatrix}, \quad \text{and} \quad A^4 = \begin{bmatrix} 1 & 0 \\ 0 & 1 \end{bmatrix}.$$

(b) For all  $1 \leq m, n \leq 4$ ,  $A^m \cdot A^n = A^{m+n} = A^r$ , where  $1 \leq r \leq 4$  and  $m + n \equiv r \pmod{4}$ . Hence the set  $\{A, A^2, A^3, A^4\}$  is closed under the binary operation of matrix multiplication. Matrix multiplication is an associative binary operation for all  $2 \times 2$  real matrices. Consequently, it is associative when restricted to these four matrices.

The matrix  $A^4 = \begin{bmatrix} 1 & 0 \\ 0 & 1 \end{bmatrix}$  is the identity element, and  $A^{-1} = A^3$ ,  $(A^2)^{-1} = A^{-2} = A^2$ ,  $(A^3)^{-1} = A^{-3} = A$ , and  $(A^4)^{-1} = A^{-4} = A^4 = A^0$ , so every element has a multiplicative inverse.

Finally, for all  $1 \leq m, n \leq 4$ ,  $A^m \cdot A^n = A^{m+n} = A^{n+m} = A^n \cdot A^m$ , so  $\{A, A^2, A^3, A^4\}$  is an abelian group under ordinary matrix multiplication.

(c) Define  $f : \{A, A^2, A^3, A^4\} \rightarrow G$  by

$$\begin{array}{lcl}
 f: A \longrightarrow i & \text{or} & f: A \longrightarrow -i \\
 A^2 \longrightarrow -1 = i^2 & & A^2 \longrightarrow -1 = (-i)^2 \\
 A^3 \longrightarrow -i = i^3 & & A^3 \longrightarrow i = (-i)^3 \\
 A^4 \longrightarrow 1 = i^4 & & A^4 \longrightarrow 1 = (-i)^4
 \end{array}$$

In either case  $f$  is an isomorphism for the two given cyclic groups of order 4.

$$\begin{array}{lll}
 3. & f(0) = (0, 0) & f(1) = (1, 1) & f(2) = (2, 0) \\
 & f(3) = (0, 1) & f(4) = (1, 0) & f(5) = (2, 1)
 \end{array}$$

4. Let  $x, y \in H$ . Since  $f$  is onto, there exist  $a, b \in G$  with  $f(a) = x, f(b) = y$ . Then  $xy = f(a)f(b) = f(ab) = f(ba)$  (since  $G$  is abelian)  $= f(b)f(a) = yx$ , so  $H$  is abelian.

5. We need to express the element  $(4, 6)$  of  $\mathbf{Z} \times \mathbf{Z}$  in terms of the elements  $(1, 3)$  and  $(3, 7)$ , so let us write

$$(4, 6) = a(1, 3) \oplus b(3, 7), \quad \text{where } a, b \in \mathbf{Z}.$$

Then  $f(4, 6) = f(a(1, 3) \oplus b(3, 7)) = f(a(1, 3)) + f(b(3, 7)) = af(1, 3) + bf(3, 7)$ .

With  $(4, 6) = a(1, 3) \oplus b(3, 7)$  we have  $4 = a + 3b$  and  $6 = 3a + 7b$ , from which it follows that  $a = -5$  and  $b = 3$ .

Consequently,  $f(4, 6) = -5g_1 + 3g_2$ .

6. (a) For each  $k \in \mathbf{Z}$ , we find that  $(k, 0) \in \mathbf{Z} \times \mathbf{Z}$  and  $f(k, 0) = k - 0 = k$ , so the function  $f$  is onto  $\mathbf{Z}$ . Furthermore, if  $(a, b), (c, d) \in \mathbf{Z} \times \mathbf{Z}$ , then  $f((a, b) \oplus (c, d)) = f(a + c, b + d) = (a + c) - (b + d) = (a - b) + (c - d) = f(a, b) + f(c, d)$ . Consequently, the function  $f$  is a homomorphism onto  $\mathbf{Z}$ .

(b) If  $f(a, b) = 0$ , then since  $f(a, b) = a - b$ , it follows that  $a = b$ . Also,  $a = b \Rightarrow a - b = 0 \Rightarrow f(a, b) = 0$ . Hence  $f(a, b) = 0$  if and only if  $a = b$ , or  $f^{-1}(0) = \{(a, a) | a \in \mathbf{Z}\}$ .

(c) Since  $f^{-1}(7) = \{(a, b) | f(a, b) = a - b = 7\}$ , here we may also write  $f^{-1}(7) = \{(b + 7, b) | b \in \mathbf{Z}\} = \{(a, a - 7) | a \in \mathbf{Z}\}$ .

(d) Let  $(a, b) \in \mathbf{Z} \times \mathbf{Z}$ . We find that  $(a, b) \in f^{-1}(E)$  if and only if  $f(a, b) = a - b$  is an even integer.

[We may also write  $f^{-1}(E) = \{(2m, 2n) | m, n \in \mathbf{Z}\} \cup \{(2m + 1, 2n + 1) | m, n \in \mathbf{Z}\}$ .]

7. (a)  $o(\pi_0) = 1, o(\pi_1) = o(\pi_2) = 3, o(r_1) = o(r_2) = o(r_3) = 2$ .

(b) (See Fig. 16.6)  $o(\pi_0) = 1, o(\pi_1) = o(\pi_3) = 4, o(\pi_2) = o(r_1) = o(r_2) = o(r_3) = o(r_4) = 2$ .

8.  $n = 2 : \left( \begin{array}{ccccc} 1 & 2 & 3 & 4 & 5 \\ 2 & 1 & 3 & 4 & 5 \end{array} \right)$  has order 2 and generates the cyclic subgroup

$$\left\{ \left( \begin{array}{ccccc} 1 & 2 & 3 & 4 & 5 \\ 2 & 1 & 3 & 4 & 5 \end{array} \right), \left( \begin{array}{ccccc} 1 & 2 & 3 & 4 & 5 \\ 1 & 2 & 3 & 4 & 5 \end{array} \right) \right\} \text{ of } S_5.$$

$n = 3 : \left( \begin{array}{ccccc} 1 & 2 & 3 & 4 & 5 \\ 2 & 3 & 1 & 4 & 5 \end{array} \right)$  has order 3 and generates the cyclic subgroup

$$\left\{ \left( \begin{array}{ccccc} 1 & 2 & 3 & 4 & 5 \\ 2 & 3 & 1 & 4 & 5 \end{array} \right), \left( \begin{array}{ccccc} 1 & 2 & 3 & 4 & 5 \\ 3 & 1 & 2 & 4 & 5 \end{array} \right), \left( \begin{array}{ccccc} 1 & 2 & 3 & 4 & 5 \\ 1 & 2 & 3 & 4 & 5 \end{array} \right) \right\} \text{ of } S_5.$$

$n = 4 : \left( \begin{array}{ccccc} 1 & 2 & 3 & 4 & 5 \\ 2 & 3 & 4 & 1 & 5 \end{array} \right)$  has order 4 and generates the cyclic subgroup

$$\left\{ \left( \begin{array}{ccccc} 1 & 2 & 3 & 4 & 5 \\ 2 & 3 & 4 & 1 & 5 \end{array} \right), \left( \begin{array}{ccccc} 1 & 2 & 3 & 4 & 5 \\ 3 & 4 & 1 & 2 & 5 \end{array} \right), \left( \begin{array}{ccccc} 1 & 2 & 3 & 4 & 5 \\ 4 & 1 & 2 & 3 & 5 \end{array} \right), \left( \begin{array}{ccccc} 1 & 2 & 3 & 4 & 5 \\ 1 & 2 & 3 & 4 & 5 \end{array} \right) \right\} \text{ of } S_5.$$

$n = 5 : \left( \begin{array}{ccccc} 1 & 2 & 3 & 4 & 5 \\ 2 & 3 & 4 & 5 & 1 \end{array} \right)$  has order 5 and generates the cyclic subgroup

$$\left\{ \left( \begin{array}{ccccc} 1 & 2 & 3 & 4 & 5 \\ 2 & 3 & 4 & 5 & 1 \end{array} \right), \left( \begin{array}{ccccc} 1 & 2 & 3 & 4 & 5 \\ 3 & 4 & 5 & 1 & 2 \end{array} \right), \left( \begin{array}{ccccc} 1 & 2 & 3 & 4 & 5 \\ 4 & 5 & 1 & 2 & 3 \end{array} \right), \right. \\ \left. \left( \begin{array}{ccccc} 1 & 2 & 3 & 4 & 5 \\ 5 & 1 & 2 & 3 & 4 \end{array} \right), \left( \begin{array}{ccccc} 1 & 2 & 3 & 4 & 5 \\ 1 & 2 & 3 & 4 & 5 \end{array} \right) \right\} \text{ of } S_5.$$

9. (a) The elements of order 10 are 4, 12, 28, and 36.

(b) The elements of order 10 are  $a^4$ ,  $a^{12}$ ,  $a^{28}$ , and  $a^{36}$ .

10. (a)  $U_{14} = \{1, 3, 5, 9, 11, 13\} = \{a \in \mathbb{Z}^+ \mid 1 \leq a \leq 13 \text{ and } \gcd(a, 14) = 1\}$ .

(b) Since

$$\begin{array}{lll} 3^1 = 3 & 3^2 = 9 & 3^3 = 13 \\ 3^4 = 11 & 3^5 = 5 & 3^6 = 1, \end{array}$$

we know that  $U_{14}$  is cyclic and  $U_{14} = \langle 3 \rangle$ .

We also find that

$$\begin{array}{lll} 5^1 = 5 & 5^2 = 11 & 5^3 = 13 \\ 5^4 = 9 & 5^5 = 3 & 5^6 = 1, \end{array}$$

so  $U_{14} = \langle 5 \rangle$ .

There are no other generators for this group.

11.  $\mathbb{Z}_5^* = \langle 2 \rangle = \langle 3 \rangle$ ;  $\mathbb{Z}_7^* = \langle 3 \rangle = \langle 5 \rangle$ ;  $\mathbb{Z}_{11}^* = \langle 2 \rangle = \langle 6 \rangle = \langle 7 \rangle = \langle 8 \rangle$ .

12. Let  $f: G \rightarrow G$ , defined by  $f(a) = a^{-1}$ , be an isomorphism. For all  $a, b \in G$ ,  $(ab)^{-1} = f(ab) = f(a)f(b) = a^{-1}b^{-1}$ . Also  $(ab)^{-1} = a^{-1}b^{-1} \implies (ab)^{-1} = (ba)^{-1} \implies ab = ba$ , so  $G$  is abelian. Conversely, the function  $f: G \rightarrow G$  defined by  $f(a) = a^{-1}$  is one-to-one and onto for any group  $G$ . For  $G$  abelian  $f(ab) = (ab)^{-1} = b^{-1}a^{-1} = a^{-1}b^{-1} = f(a)f(b)$ , and  $f$  is an isomorphism.

13. Let  $(G, +)$ ,  $(H, *)$ ,  $(K, \cdot)$  be the given groups. For any  $x, y \in G$ ,  $(g \circ f)(x + y) = g(f(x + y)) = g(f(x) * f(y)) = (g(f(x))) \cdot (g(f(y))) = ((g \circ f)(x)) \cdot ((g \circ f)(y))$ , since  $f, g$  are homomorphisms. Hence,  $g \circ f : G \rightarrow K$  is a group homomorphism.
14. (a) From Exercise 16 of Section 16.1 we know that  $G = \langle \omega \rangle$ . It is also true that  $G = \langle \omega^3 \rangle = \langle \omega^5 \rangle = \langle \omega^7 \rangle$ .
- (b) Define  $f : G \rightarrow \mathbf{Z}_8$  by  $f(\omega^n) = [n]$ ,  $1 \leq n \leq 8$ . If  $1 \leq k, m \leq 8$ , then  $\omega^k = \omega^m \iff k = m \iff [k] = [m] \iff f(\omega^k) = f(\omega^m)$ , so  $f$  is a one-to-one function. Since  $|G| = |\mathbf{Z}_8|$ , it follows from Theorem 5.11 that  $f$  is also onto. Finally, for  $1 \leq k, m \leq 8$ ,  $f(\omega^k \cdot \omega^m) = f(\omega^{k+m}) = [k + m] = [k] + [m] = f(\omega^k) + f(\omega^m)$ , so  $f$  is an isomorphism. Note: Three other isomorphisms are also possible here. They are determined, in each case, by the image of  $\omega$ . We find these to be:  
 $f_1 : G \rightarrow \mathbf{Z}_8$ , where  $f_1(\omega) = [3]$ ;  
 $f_2 : G \rightarrow \mathbf{Z}_8$ , where  $f_2(\omega) = [5]$ ; and  
 $f_3 : G \rightarrow \mathbf{Z}_8$ , where  $f_3(\omega) = [7]$ .
15. (a)  $(\mathbf{Z}_{12}, +) = \langle 1 \rangle = \langle 7 \rangle = \langle 11 \rangle$   
 $(\mathbf{Z}_{16}, +) = \langle 1 \rangle = \langle 3 \rangle = \langle 5 \rangle = \langle 7 \rangle = \langle 9 \rangle = \langle 11 \rangle = \langle 13 \rangle = \langle 15 \rangle$   
 $(\mathbf{Z}_{24}, +) = \langle 1 \rangle = \langle 5 \rangle = \langle 7 \rangle = \langle 11 \rangle = \langle 13 \rangle = \langle 17 \rangle = \langle 19 \rangle = \langle 23 \rangle$
- (b) Let  $G = \langle a^k \rangle$ . Since  $G = \langle a \rangle$ ,  $a = (a^k)^s$  for some  $s \in \mathbf{Z}$ . Then  $a^{1-ks} = e$ , so  $1 - ks = tn$  since  $o(a) = n$ .  $1 - ks = tn \implies 1 = ks + tn \implies \gcd(k, n) = 1$ . Conversely, let  $G = \langle a \rangle$  where  $a^k \in G$  and  $\gcd(k, n) = 1$ . Then  $\langle a^k \rangle \subseteq G$ .  $\gcd(k, n) = 1 \implies 1 = ks + tn$ , for some  $s, t \in \mathbf{Z} \implies a = a^1 = a^{ks+tn} = (a^k)^s (a^n)^t = (a^k)^s (e)^t = (a^k)^s \in \langle a^k \rangle$ . Hence  $G \subseteq \langle a^k \rangle$ . So  $G = \langle a^k \rangle$ , or  $a^k$  generates  $G$ .
- (c)  $\phi(n)$ .
16. If  $k \nmid n$ , let  $n = qk + r$ ,  $0 < r < k$ . Then  $f(a^n) = f(e_G) = e_H$  and  $f(a^n) = (f(a))^n = (f(a))^{qk+r} = (f(a)^k)^q (f(a))^r = (f(a))^r$ . But  $(f(a))^r = e_H$  with  $0 < r < k$  contradicts  $o(f(a)) = k$ . Consequently,  $k \mid n$ .

### Section 16.3

1. (a)  $\left\{ \begin{pmatrix} 1 & 2 & 3 & 4 \\ 2 & 3 & 4 & 1 \end{pmatrix}, \begin{pmatrix} 1 & 2 & 3 & 4 \\ 3 & 4 & 1 & 2 \end{pmatrix}, \begin{pmatrix} 1 & 2 & 3 & 4 \\ 4 & 1 & 2 & 3 \end{pmatrix}, \begin{pmatrix} 1 & 2 & 3 & 4 \\ 1 & 2 & 3 & 4 \end{pmatrix} \right\}$   
 (b)

$$\begin{pmatrix} 1 & 2 & 3 & 4 \\ 2 & 1 & 4 & 3 \end{pmatrix} H = \left\{ \begin{pmatrix} 1 & 2 & 3 & 4 \\ 3 & 2 & 1 & 4 \end{pmatrix}, \begin{pmatrix} 1 & 2 & 3 & 4 \\ 4 & 3 & 2 & 1 \end{pmatrix}, \begin{pmatrix} 1 & 2 & 3 & 4 \\ 1 & 4 & 3 & 2 \end{pmatrix}, \begin{pmatrix} 1 & 2 & 3 & 4 \\ 2 & 1 & 4 & 3 \end{pmatrix} \right\}$$

$$\begin{pmatrix} 1 & 2 & 3 & 4 \\ 4 & 2 & 3 & 1 \end{pmatrix} H = \left\{ \begin{pmatrix} 1 & 2 & 3 & 4 \\ 1 & 3 & 4 & 2 \end{pmatrix}, \begin{pmatrix} 1 & 2 & 3 & 4 \\ 2 & 4 & 1 & 3 \end{pmatrix}, \begin{pmatrix} 1 & 2 & 3 & 4 \\ 3 & 1 & 2 & 4 \end{pmatrix}, \begin{pmatrix} 1 & 2 & 3 & 4 \\ 4 & 2 & 3 & 1 \end{pmatrix} \right\}$$



$$K = \langle [4] \rangle = \langle 4 \rangle = \{0, 4, 8, 12, 16, 20\}$$

$$1 + K = \{1, 5, 9, 13, 17, 21\}$$

$$2 + K = \{2, 6, 10, 14, 18, 22\}$$

$$3 + K = \{3, 7, 11, 15, 19, 23\}$$

5. From Lagrange's Theorem we know that  $|K| = 66 (= 2 \cdot 3 \cdot 11)$  divides  $|H|$  and that  $|H|$  divides  $|G| = 660 (= 2^2 \cdot 3 \cdot 5 \cdot 11)$ . Consequently, since  $K \neq H$  and  $H \neq G$ , it follows that  $|H|$  is  $2(2 \cdot 3 \cdot 11) = 132$  or  $5(2 \cdot 3 \cdot 11) = 330$ .

6. Let  $G$  be the set of units in  $R$ .  $u \in G \implies G \neq \emptyset$ . Also, the elements of  $G$  are associative under multiplication (inherited from the multiplication in  $R$ ). If  $x, y \in G$  then  $x^{-1}, y^{-1} \in R$  (and in  $G$ ), and  $(xy)(y^{-1}x^{-1}) = u = (y^{-1}x^{-1})(xy)$ , so  $xy \in G$ . Consequently,  $G$  is a multiplicative group.

7. (a)

	(1)(2)(3)(4)	(12)(34)	(13)(24)	(14)(23)
(1)(2)(3)(4)	(1)(2)(3)(4)	(12)(34)	(13)(24)	(14)(23)
(12)(34)	(12)(34)	(1)(2)(3)(4)	(14)(23)	(13)(24)
(13)(24)	(13)(24)	(14)(23)	(1)(2)(3)(4)	(12)(34)
(14)(23)	(14)(23)	(13)(24)	(12)(34)	(1)(2)(3)(4)

It follows from Theorem 16.3 that  $H$  is a subgroup of  $G$ . And since the entries in the above table are symmetric about the diagonal from the upper left to the lower right, we have  $H$  an abelian subgroup of  $G$ .

(b) Since  $|G| = 4! = 24$  and  $|H| = 4$ , there are  $24/4 = 6$  left cosets of  $H$  in  $G$ .

(c) Consider the function  $f : H \rightarrow \mathbf{Z}_2 \times \mathbf{Z}_2$  defined by

$$\begin{aligned} f : (1)(2)(3)(4) &\rightarrow (0, 0), & f : (12)(34) &\rightarrow (1, 0), \\ f : (13)(24) &\rightarrow (0, 1), & f : (14)(23) &\rightarrow (1, 1). \end{aligned}$$

This function  $f$  is one-to-one and onto, and for all  $x, y \in H$  we find that

$$f(x \cdot y) = f(x) \oplus f(y).$$

Consequently,  $f$  is an isomorphism.

[Note: There are other possible answers that can be given here. In fact, there are six possible isomorphisms that one can define here.]

8. Let  $o(a) = k$ . Then  $|\langle a \rangle| = k$ , so by Lagrange's Theorem  $k$  divides  $n$ . Hence  $a^n = a^{km} = (a^k)^m = e^m = e$ .

9. (a) If  $H$  is a proper subgroup of  $G$ , then by Lagrange's Theorem  $|H|$  is 2 or  $p$ . If  $|H| = 2$ , then  $H = \{e, x\}$  where  $x^2 = e$ , so  $H = \langle x \rangle$ . If  $|H| = p$ , let  $y \in H$ , where  $y \neq e$ . Then  $o(y) = p$ , so  $H = \langle y \rangle$ .

(b) Let  $x \in G$ ,  $x \neq e$ . Then  $o(x) = p$  or  $o(x) = p^2$ . If  $o(x) = p$ , then  $|\langle x \rangle| = p$ . If  $o(x) = p^2$ , then  $G = \langle x \rangle$  and  $\langle x^p \rangle$  is a subgroup of  $G$  of order  $p$ .

10. Corollary 16.1.  $o(a) = |\langle a \rangle|$ . By Lagrange's Theorem  $|\langle a \rangle|$  divides  $|G|$ , so  $o(a) \mid |G|$ .  
 Corollary 16.2. Let  $G$  be a group with  $|G| = p$ , a prime. Let  $x \in G$ ,  $x \neq e$ . By Corollary 16.1,  $o(x) = p$ , so  $G = \langle x \rangle$  and  $G$  is cyclic.
11. (a) Let  $x \in H \cap K$ .  $x \in H \implies o(x) \mid 10 \implies o(x) = 1, 2, 5, \text{ or } 10$ .  $x \in K \implies o(x) \mid 21 \implies o(x) = 1, 3, 7, \text{ or } 21$ . Hence  $o(x) = 1$  and  $x = e$ .
12. (a) For all  $a \in G$ ,  $a^{-1}a = e \in H$ , so  $a\mathcal{R}a$  and  $\mathcal{R}$  is reflexive. If  $a, b \in G$  and  $a\mathcal{R}b$ , then  $a\mathcal{R}b \implies a^{-1}b \in H \implies (a^{-1}b)^{-1} \in H$  (because  $H$  is a subgroup)  $\implies b^{-1}a \in H \implies b\mathcal{R}a$ , so  $\mathcal{R}$  is symmetric. Finally, let  $a, b, c \in G$  with  $a\mathcal{R}b$  and  $b\mathcal{R}c$ . Then we have  $a^{-1}b, b^{-1}c \in H$  and since  $H$  is closed under the group operation,  $(a^{-1}b)(b^{-1}c) = a^{-1}(bb^{-1})c = a^{-1}(e)c = a^{-1}c \in H$ , so  $a\mathcal{R}c$  and  $\mathcal{R}$  is transitive. Hence  $\mathcal{R}$  is an equivalence relation.
- (b)  $a\mathcal{R}b \implies a^{-1}b \in H \implies a^{-1}b = h$ , where  $h \in H \implies bH = (ah)H = a(hH) = aH$ . Conversely,  $aH = bH \implies a \in bH \implies a = bh$  for some  $h \in H \implies h^{-1} = a^{-1}b$ , where  $h^{-1} \in H \implies a^{-1}b \in H$  and  $a\mathcal{R}b$ .
- (c) Let  $x \in [a]$ . Then  $x\mathcal{R}a$  so  $x^{-1}a \in H$ . Since  $H$  is a subgroup,  $(x^{-1}a)^{-1} = a^{-1}x \in H$ . So  $a^{-1}x = h \in H$  and  $x = ah \in aH$ . Hence  $[a] \subseteq aH$ . Conversely, if  $y \in aH$  then  $y = ah_1$ , for some  $h_1 \in H$ .  $y = ah_1 \implies a^{-1}y = h_1 \in H \implies a\mathcal{R}y$ . With  $\mathcal{R}$  symmetric we also have  $y\mathcal{R}a$ , and so  $y \in [a]$ . So here we find  $aH \subseteq [a]$ . With both inclusions established it now follows that  $aH = [a]$ .
- (d) Define  $f : aH \rightarrow H$  by  $f(ah) = h$ , for  $h \in H$ .  $ah_1 = ah_2 \iff h_1 = h_2 \iff f(ah_1) = f(ah_2)$ , so  $f$  is a one-to-one function. Also, for  $h \in H$ ,  $f^{-1}(h) \supseteq \{ah\}$ , so  $f^{-1}(h) \neq \emptyset$ , and  $f$  is onto. Hence  $f$  is bijective and  $|aH| = |H|$ .
- (e) Since  $\mathcal{R}$  is an equivalence relation on  $G$ ,  $\mathcal{R}$  induces a partition of  $G$  as
- $$G = [a_1] \cup [a_2] \cup \dots \cup [a_t].$$
- Hence  $[a_i] = a_iH$  for all  $1 \leq i \leq t$ , and  $|a_iH| = |H| = m$  for all  $1 \leq i \leq t$ . Consequently,  $|G| = t|H|$ , and  $|H|$  divides  $|G|$ .
13. (a) In  $(\mathbb{Z}_p^*, \cdot)$  there are  $p - 1$  elements, so by Exercise 8, for each  $[x] \in (\mathbb{Z}_p^*, \cdot)$ ,  $[x]^{p-1} = [1]$ , or  $x^{p-1} \equiv 1 \pmod{p}$ , or  $x^p \equiv x \pmod{p}$ . For all  $a \in \mathbb{Z}$ , if  $p \mid a$  then  $a \equiv 0 \pmod{p}$  and  $a^p \equiv 0 \equiv a \pmod{p}$ . If  $p \nmid a$ , then  $a \equiv b \pmod{p}$ ,  $1 \leq b \leq p-1$  and  $a^p \equiv b^p \equiv b \equiv a \pmod{p}$ .
- (b) In the group  $G$  of units of  $\mathbb{Z}_n$  there are  $\phi(n)$  units. If  $a \in \mathbb{Z}$  and  $\gcd(a, n) = 1$  then  $[a] \in G$  and  $[a]^{\phi(n)} = [1]$  or  $a^{\phi(n)} \equiv 1 \pmod{n}$ .
- (c) and (d) These results follow from Exercises 6 and 8. They are special cases of Exercise 8.

## Section 16.4

1. Here  $n = 2573$  and  $e = 7$ .

The assignment for the given plaintext is:

IN	VE	ST	IN	ST	OC	KS
0813	2104	1819	0813	1819	1402	1018

Since

$(0813)^7 \bmod 2573 = 0462$	$(1819)^7 \bmod 2573 = 1809$
$(2104)^7 \bmod 2573 = 0170$	$(1402)^7 \bmod 2573 = 1981$
$(1819)^7 \bmod 2573 = 1809$	$(1018)^7 \bmod 2573 = 0305,$
$(0813)^7 \bmod 2573 = 0462$	

the ciphertext is

0462 0170 1809 0462 1809 1981 0305

2. Here  $n = 1459$  and  $e = 5$ .

The assignment for the given plaintext is:

OR	DE	RA	PI	ZZ	AX
1417	0304	1700	1508	2525	0023

Since

$(1417)^5 \bmod 1459 = 0152$	$(1508)^5 \bmod 1459 = 1177$
$(0304)^5 \bmod 1459 = 0466$	$(2525)^5 \bmod 1459 = 0055$
$(1700)^5 \bmod 1459 = 1318$	$(0023)^5 \bmod 1459 = 0694$

the ciphertext is

0152 0466 1318 1177 0055 0694.

3. Here  $n = 2501 = (41)(61)$ , so  $r = \phi(n) = (40)(60) = 2400$ . Further,  $e = 11$  is a unit in  $\mathbb{Z}_{2400}$  and  $d = e^{-1} = 1091$ .

Since the encrypted ciphertext is

1418 1436 2370 1102 1805 0250,

we calculate the following:

$(1418)^{1091} \bmod 2501 = 0317$	$(1102)^{1091} \bmod 2501 = 0005$
$(1436)^{1091} \bmod 2501 = 0821$	$(1805)^{1091} \bmod 2501 = 0411$
$(2370)^{1091} \bmod 2501 = 0418$	$(0250)^{1091} \bmod 2501 = 2423$

Consequently, the assignment for the original message is

0317 0821 0418 0005 0411 2423

and this reveals the message as

DRIVE SAFELYX.

4. Here  $n = 3053 = (43)(71)$ , so  $r = \phi(n) = (42)(70) = 2940$ . Further,  $e = 17$  is a unit in  $\mathbb{Z}_{2940}$  and  $d = e^{-1} = 173$ .

Since the encrypted ciphertext is

0986 3029 1134 1105 1232 2281 2967 0272 1818 2398 1153,  
we calculate the following:

$$\begin{array}{ll}
 (0986)^{173} \bmod 3053 = 1907 & (2967)^{173} \bmod 3053 = 2408 \\
 (3029)^{173} \bmod 3053 = 0417 & (0272)^{173} \bmod 3053 = 1313 \\
 (1134)^{173} \bmod 3053 = 0408 & (1818)^{173} \bmod 3053 = 2012 \\
 (1105)^{173} \bmod 3053 = 1818 & (2398)^{173} \bmod 3053 = 0104 \\
 (1232)^{173} \bmod 3053 = 0005 & (1153)^{173} \bmod 3053 = 1718 \\
 (2281)^{173} \bmod 3053 = 0419 &
 \end{array}$$

Consequently, the assignment for the original message is  
1907 0417 0408 1818 0005 0419 2408 1313 2012 0104 1718  
and this reveals the message as

THERE IS SAFETY IN NUMBERS.

5. Here  $n = pq = 121,361$  and  $r = \phi(n) = 120,432$ .

Since  $p + q = n - r + 1 = 930$  and  $p - q = \sqrt{(n - r + 1)^2 - 4n} = \sqrt{864,900 - 485,444} = \sqrt{379,456} = 616$ , it follows that  
 $p = 157$  and  $q = 773$ .

6. Here  $n = pq = 5,446,367$  and  $r = \phi(n) = 5,441,640$ .

Since  $p + q = n - r + 1 = 4728$  and  $p - q = \sqrt{(n - r + 1)^2 - 4n} = \sqrt{22,353,984 - 21,785,468} = \sqrt{568516} = 754$ , it follows that  
 $p = 1987$  and  $q = 2741$ .

### Section 16.5

1. (a)  $e = 0001001$                       (b)  $r = 1111011$                       (c)  $c = 0101000$

2. (a)  $(0.95)^8(0.05)$                       (b)  $(0.95)^7(0.05)^2$   
 (c)  $\binom{9}{1}(0.95)^8(0.05)$                       (d)  $\binom{9}{2}(0.95)^7(0.05)^2$   
 (e)  $\binom{9}{3}(0.95)^6(0.05)^3$                       (f)  $\binom{7}{3}(0.95)^6(0.05)^3$

3. (a) (i)  $D(111101100) = 101$                       (ii)  $D(000100011) = 000$   
 (iii)  $D(010011111) = 011$

(b) 000000000, 000000001, 100000000

(c) 64

4. (a)  $(0.95)^5 + \binom{5}{1}(0.05)(0.95)^4 + \binom{5}{2}(0.05)^2(0.95)^3$

$$(b) \left[ (0.95)^5 + \binom{5}{1}(0.05)(0.95)^4 + \binom{5}{2}(0.05)^2(0.95)^3 \right]^3$$

$$(c) D(r) = 01$$

$$(d) 0000000000, 1000000000, 0000000001$$

$$(e) 256$$

### Sections 16.6 and 16.7

$$1. S(101010, 1) = \{101010, 001010, 111010, 100010, 101110, 101000, 101011\}$$

$$S(111111, 1) = \{111111, 011111, 101111, 110111, 111011, 111101, 111110\}$$

$$2. S(000000, 1) = \{000000, 100000, 010000, 001000, 000100, 000010, 000001\}$$

$$S(010101, 1) = \{010101, 110101, 000101, 011101, 010001, 010111, 010100\}$$

$$(a) D(110101) = 01$$

$$(b) D(101011) = 10$$

$$(c) D(001111) = 00$$

$$(d) D(110000) = 00$$

$$3. (a) |S(x, 1)| = 11; \quad |S(x, 2)| = 56; \quad |S(x, 3)| = 176$$

$$(b) |S(x, k)| = 1 + \binom{n}{1} + \binom{n}{2} + \dots + \binom{n}{k} = \sum_{i=0}^k \binom{n}{i}$$

$$4. k = 8; \quad n = 4$$

5. (a) The minimum distance between code words is 3. The code can detect all errors of weight  $\leq 2$  or correct all single errors.

(b) The minimum distance between code words is 5. The code can detect all errors of weight  $\leq 4$  or correct all errors of weight  $\leq 2$ .

(c) The minimum distance between code words is 2. The code detects all single errors but has no correction capability.

(d) The minimum distance between code words is 3. The code can detect all errors of weight  $\leq 2$  or correct all single errors.

$$6. (a) (i) H \cdot (111101)^{tr} = (101)^{tr}, \text{ so } c = 110101 \text{ and } D(c) = 110$$

$$(ii) H \cdot (110101)^{tr} = (000)^{tr}, \text{ so } c = 110101 \text{ and } D(c) = 110$$

$$(iii) H \cdot (001111)^{tr} = (010)^{tr}, \text{ so } c = 001101 \text{ and } D(c) = 001$$

$$(iv) H \cdot (100100)^{tr} = (010)^{tr}, \text{ so } c = 100110 \text{ and } D(c) = 100$$

$$(v) H \cdot (110001)^{tr} = (100)^{tr}, \text{ so } c = 110101 \text{ and } D(c) = 110$$

$$(vi) H \cdot (111111)^{tr} = (111)^{tr}, \text{ which doesn't appear among the columns of } H.$$

Assuming a double error,

$$(1) \text{ if } 111 = 110 + 001, \text{ then } c = 011110 \text{ and } D(c) = 011;$$

$$(2) \text{ if } 111 = 011 + 100, \text{ then } c = 101011 \text{ and } D(c) = 101; \text{ and}$$

$$(3) \text{ if } 111 = 101 + 010, \text{ then } c = 110101 \text{ and } D(c) = 110.$$

$$(vii) H \cdot (111100)^{tr} = (100)^{tr}, \text{ so } c = 111000 \text{ and } D(c) = 111$$

$$(viii) H \cdot (010100)^{tr} = (111)^{tr}, \text{ which doesn't appear among the columns of } H.$$

Assuming a double error,

- (1) if  $111 = 110 + 001$ , then  $c = 110101$  and  $D(c) = 110$ ;
- (2) if  $111 = 011 + 100$ , then  $c = 000000$  and  $D(c) = 000$ ; and
- (3) if  $111 = 101 + 010$ , then  $c = 011110$  and  $D(c) = 011$ .

(b) No. The results in (vi) and (viii) are not unique.

7. (a)  $C = \{00000, 10110, 01011, 11101\}$ . The minimum distance between code words is 3, so the code can detect all errors of weight  $\leq 2$  or correct all single errors.

$$(b) H = \begin{bmatrix} 1 & 0 & 1 & 0 & 0 \\ 1 & 1 & 0 & 1 & 0 \\ 0 & 1 & 0 & 0 & 1 \end{bmatrix}$$

(c) (i) 01 (ii) 11 (v) 11 (vi) 10

For (iii) and (iv) the syndrome is  $(111)^{tr}$  which is not a column of  $H$ . Assuming a double error, if  $(111)^{tr} = (110)^{tr} + (001)^{tr}$ , then the decoded received word is 01 (for (iii)) and 10 (for (iv)). If  $(111)^{tr} = (011)^{tr} + (100)^{tr}$ , we get 10 (for (iii)) and 01 (for (iv)).

$$8. (a) G = \begin{bmatrix} 1 & 0 & 0 & 1 & 1 & 1 \\ 0 & 1 & 0 & 0 & 1 & 0 \\ 0 & 0 & 1 & 1 & 0 & 1 \end{bmatrix}$$

$C = \{000000, 100111, 010010, 001101, 110101, 101010, 011111, 111000\}$

(b) No. The second and fifth columns of  $H$  are the same.

9.  $G = [I_8|A]$  where  $I_8$  is the  $8 \times 8$  multiplicative identity matrix and  $A$  is a column of eight 1's.  $H = [A^{tr}|1] = [11111111|1]$ .
10. (a) For each  $x \in \{0, 1\}$ ,  $xG = xxxxxxxx$ .
- (b)  $H = [A|I_8]$  where  $I_8$  is the  $8 \times 8$  multiplicative identity and  $A$  is a column of eight 1's.
11. Compare the generator (parity-check) matrix in Exercise 9 with the parity-check (generator) matrix in Exercise 10.
12. Let  $c \in \mathbb{Z}_2^n$  be a code word. For all  $x \in S(c, k)$  the decoding function of Theorem 16.13 decodes  $x$ , and if  $c_1, c_2$  are code words  $S(c_1, k) \cap S(c_2, k) = \emptyset$ .  $x \in S(c, k) \iff d(x, c) \leq k$ , so  $|S(c, k)| = \sum_{i=0}^k \binom{n}{i}$ . Consequently,  $|M(n, k)| = |\sum_{i=0}^k \binom{n}{i}|$  accounts for all received words in  $\mathbb{Z}_2^n$  that are code words or differ from a code word in  $k$  or fewer positions. It follows then that  $|M(n, k)| = |\sum_{i=0}^k \binom{n}{i}| \leq |\mathbb{Z}_2^n| = 2^n$ .

For the lower (Gilbert) bound we appeal to error detection. If  $r \in \mathbb{Z}_2^n$  and  $d(c, r) \leq 2k$ , then by Theorem 16.12 we are able to detect  $r$  as an incorrect transmission. So for all code words  $c$ ,  $S(c, 2k)$  accounts for the code word  $c$  as well as those received words  $r$  where  $d(c, r) \leq 2k$ , but here we may have  $S(c_1, 2k) \cap S(c_2, 2k) \neq \emptyset$  for distinct code words

$c_1, c_2$ . If  $2^n > |M(n, k)| \left[ \sum_{i=0}^{2k} \binom{n}{i} \right]$ , then there is an element  $c^* \in \mathbb{Z}_2^n$  where  $d(c^*, c) > 2k$  for all code words  $c$ . So we can add  $c^*$  to the present set of code words and get a larger code where the minimal distance between code words is still  $2k + 1$ . This, however, contradicts the maximal size  $|M(n, k)|$  so  $2^n \leq |M(n, k)| \left[ \sum_{i=0}^{2k} \binom{n}{i} \right]$ .

### Sections 16.8 and 16.9

1.  $\binom{256}{2}$  calculations are needed to find the minimum distance between code words. (A calculation here determines the distance between a pair of code words.) If  $E$  is a group homomorphism we need to calculate the weights of the 255 nonzero code words.
2. (a)

$$H = \begin{bmatrix} 1 & 0 & 1 & 1 & 0 & 0 \\ 1 & 1 & 0 & 0 & 1 & 0 \\ 0 & 1 & 1 & 0 & 0 & 1 \end{bmatrix}$$

Received word $r$	$H \cdot r^{tr}$	$c = r + e$	$D(c)$
000011	$(011)^{tr}$	010011	010
100011	$(101)^{tr}$	101011	101
111110	$(110)^{tr}$	011110	011
100001	$(111)^{tr}$	110101	110
001100	$(001)^{tr}$	001101	001
011110	$(000)^{tr}$	011110	011
001111	$(010)^{tr}$	001101	001
111100	$(100)^{tr}$	111000	111

(b) If 100001 is used (in the last row of Table 16.8) as the coset leader instead of 010100, then for  $r = 100001$ ,  $H \cdot r^{tr} = (111)^{tr}$ . However, if  $r = 100001$  and  $x = 100001$ , then  $c = 000000$  (not 110101) and  $D(c) = 000$  (not 110).

3. (a)

Syndrome	Coset Leader			
000	00000	10110	01011	11101
110	10000	00110	11011	01101
011	01000	11110	00011	10101
100	00100	10010	01111	11001
010	00010	10100	01001	11111
001	00001	10111	01010	11100
101	11000	01110	10011	00101
111	01100	11010	00111	10001

[The last two rows are not unique.]

(b)

Received Word	Code Word	Decoded Message
11110	10110	10
11101	11101	11
11011	01011	01
10100	10110	10
10011	01011	01
10101	11101	11
11111	11101	11
01100	00000	00

4.

$$G = \begin{bmatrix} 1 & 0 & 0 & 0 & 1 & 1 & 0 \\ 0 & 1 & 0 & 0 & 1 & 0 & 1 \\ 0 & 0 & 1 & 0 & 0 & 1 & 1 \\ 0 & 0 & 0 & 1 & 1 & 1 & 1 \end{bmatrix}$$

(a)

$$(1000) G = 1000110$$

$$(1011) G = 1011010$$

$$(1001) G = 1001001$$

$$(1100) G = 1100011$$

$$(1110) G = 1110000$$

$$(1111) G = 1111111$$

(b)

Received word $r$	$H \cdot r^{tr}$	$c$	$D(c)$
1100001	$(010)^{tr}$	1100011	1100
1110111	$(111)^{tr}$	1111111	1111
0010001	$(010)^{tr}$	0010011	0010
0011100	$(000)^{tr}$	0011100	0011

(c)

Syndrome	Coset Leader
000	0000000
110	1000000
101	0100000
011	0010000
111	0001000
100	0000100
010	0000010
001	0000001

(d) Same results as in part (b).

5. (a)  $G$  is  $57 \times 63$ ;  $H$  is  $6 \times 63$

(b) The rate is  $57/63$ .

6. The rate of the (3,1) triple repetition code is  $1/3$ . The rate for the Hamming (7,4) code is  $4/7$ . Since  $(4/7) > (1/3)$  the Hamming code is more efficient.

7. (a) The Hamming (7,4) code corrects all single errors in transmission, so the probability of the correct decoding of 1011 is  $(0.99)^7 + \binom{7}{1}(0.99)^6(0.01)$

(b)  $[(0.99)^7 + \binom{7}{1}(0.99)^6(0.01)]^5$

### Section 16.10

1. (a)  $\pi_3^* = (C_1 C_2 C_3 C_4 C_5 C_6 C_7 C_8 C_9 C_{10} C_{11} C_{12} C_{13} C_{14} C_{15} C_{16} / C_1 C_5 C_2 C_3 C_4 C_6 C_8 C_7 C_9 C_{11} C_{10} C_{15} C_{12} C_{13} C_{14} C_{16})$

$$r_2^* = (C_1 C_2 C_3 C_4 C_5 C_6 C_7 C_8 C_9 C_{10} C_{11} C_{12} C_{13} C_{14} C_{15} C_{16} / C_1 C_5 C_4 C_3 C_2 C_6 C_9 C_8 C_7 C_{11} C_{10} C_{13} C_{12} C_{15} C_{14} C_{16})$$

(b)  $r_3^{-1} = r_3$

$$r_3^* = (r_3^{-1})^* = (C_1 C_2 C_3 C_4 C_5 C_6 C_7 C_8 C_9 C_{10} C_{11} C_{12} C_{13} C_{14} C_{15} C_{16} / C_1 C_2 C_6 C_4 C_3 C_7 C_8 C_9 C_8 C_{10} C_{11} C_{14} C_{13} C_{12} C_{15} C_{16})$$

$$= (r_3^*)^{-1}$$

(c)  $\pi_1^* r_1^* = (C_1 C_2 C_3 C_4 C_5 C_6 C_7 C_8 C_9 C_{10} C_{11} C_{12} C_{13} C_{14} C_{15} C_{16} / C_1 C_2 C_5 C_4 C_3 C_7 C_8 C_3 C_8 C_{10} C_{11} C_{14} C_{13} C_{12} C_{15} C_{16})$

$$= r_3^* = (\pi_1 r_1)^*$$

2.  $\alpha = (1247365)$                        $\beta = (135)(2674)$   
 $\gamma = (123)(476)(5)$                  $\delta = (14)(2)(375)(6)$

3. (a)  $o(\alpha) = 7$ ;     $o(\beta) = 12$ ;     $o(\gamma) = 3$ ;     $o(\delta) = 6$ .

(b) Let  $\alpha \in S_n$ , with  $\alpha = c_1 c_2 \dots c_k$ , a product of disjoint cycles. Then  $o(\alpha)$  is the lcm

of  $\ell(c_1), \ell(c_2), \dots, \ell(c_k)$ , where  $\ell(c_i) = \text{length of } c_i, 1 \leq i \leq k$ .

4. Here  $G$  is the group of Example 16.7.

(a)

$$\begin{array}{lll} \Psi(\pi_0^*) = 2^3 & \Psi(\pi_1^*) = 2 & \Psi(\pi_2^*) = 2 \\ \Psi(r_1^*) = 2^2 & \Psi(r_2^*) = 2^2 & \Psi(r_3^*) = 2^2 \end{array}$$

The number of distinct colorings is  $(1/6)[2^3 + 2 + 2 + 3(2^2)] = 4$ .

(b)

$$\begin{array}{lll} \Psi(\pi_0^*) = 3^3 & \Psi(\pi_1^*) = 3 & \Psi(\pi_2^*) = 3 \\ \Psi(r_1^*) = 3^2 & \Psi(r_2^*) = 3^2 & \Psi(r_3^*) = 3^2 \end{array}$$

The number of distinct colorings is  $(1/6)[3^3 + 3 + 3 + 3(3^2)] = 10$ .

5. For  $0 \leq i \leq 4$ , let  $\pi_i$  denote a clockwise rotation through  $i(72^\circ)$ . Also, there are five reflections  $r_i, 1 \leq i \leq 5$ , each about a line through a vertex and the midpoint of the opposite side. Here  $|G| = 10$ .

$$\begin{array}{ll} \text{(a)} \quad \Psi(\pi_0^*) = 2^5 & \Psi(\pi_i^*) = 2, \quad 2 \leq i \leq 4 \\ & \Psi(r_i^*) = 2^3, \quad 1 \leq i \leq 5. \end{array}$$

The number of distinct configurations is  $(1/10)[2^5 + 4(2) + 5(2^3)] = 8$ .

(b) 39

6. (a) (i) Free to move in two dimensions: Here  $G = \{\pi_0, \pi_1, \pi_2, \pi_3\}$  where the  $\pi_i, 0 \leq i \leq 3$ , are as in Example 16.28.

$$\Psi(\pi_0^*) = 3^4, \Psi(\pi_1^*) = \Psi(\pi_3^*) = 3, \Psi(\pi_2^*) = 3^2.$$

The number of distinct configurations is  $(1/4)[3^4 + 2(3) + 3^2] = 24$ .

(ii) Free to move in three dimensions: Here  $G$  is the group of Example 16.28.

$$\Psi(\pi_0^*) = 3^4, \Psi(\pi_1^*) = \Psi(\pi_3^*) = 3, \Psi(\pi_2^*) = 3^2.$$

$$\Psi(r_1^*) = 3^3 = \Psi(r_2^*), \Psi(r_3^*) = 3^2 = \Psi(r_4^*).$$

The number of distinct configurations is  $(1/8)[3^4 + 2(3) + 3^2 + 2(3^3) + 2(3^2)] = 21$ .

(b) (i) Two dimensions: 51                      (ii) Three dimensions: 39

7. (a)  $G = \{\pi_i | 0 \leq i \leq 3\}$ , where  $\pi_i$  is a clockwise rotation through  $i \cdot 90^\circ$ . The number of distinct bracelets is  $(1/4)[4^4 + 4 + 4^2 + 4] = 70$ .

(b)  $G = \{\pi_i | 0 \leq i \leq 3\} \cup \{r_i | 1 \leq i \leq 4\}$ , where each  $r_i, 1 \leq i \leq 4$ , is one of the two reflections about a line through two opposite beads of the midpoints of two opposite lengths of wire. Then the number of distinct bracelets is  $(1/8)[4^4 + 4 + 4^2 + 4 + 4^3 + 4^3 + 4^2 + 4^2] = 55$ .

$$8. \quad \text{(a)} \quad \begin{array}{|c|c|c|} \hline 1 & 2 & 3 \\ \hline \square & \cdot & \square \\ \hline \end{array} \quad G = \left\{ \pi_0 = \begin{pmatrix} 1 & 2 & 3 \\ 1 & 2 & 3 \end{pmatrix}, \quad \pi_1 = \begin{pmatrix} 1 & 2 & 3 \\ 3 & 2 & 1 \end{pmatrix} \right\}$$

$$(1/2)[3^3 + 3^2] = 18; \quad (1/2)[4^3 + 4^2] = 40$$

$$(b) \quad G = \left\{ \pi_0 = \begin{pmatrix} 1 & 2 & 3 & 4 \\ 1 & 2 & 3 & 4 \end{pmatrix}, \quad \pi_1 = \begin{pmatrix} 1 & 2 & 3 & 4 \\ 4 & 3 & 2 & 1 \end{pmatrix} \right\}$$

$$(1/2)[3^4 + 3^2] = 45; \quad (1/2)[4^4 + 4^2] = 136$$

$$(c) \quad n \text{ odd: } (1/2)[3^n + 3^{(n+1)/2}]; \quad (1/2)[4^n + 4^{(n+1)/2}]$$

$$n \text{ even: } (1/2)[3^n + 3^{n/2}]; \quad (1/2)[4^n + 4^{n/2}]$$

$$(d) \quad (a) \quad (1/2)[3 \cdot 2 \cdot 2 + 3 \cdot 2] = 9; \quad (1/2)[4 \cdot 3 \cdot 3 + 4 \cdot 3] = 24$$

$$(b) \quad (1/2)[3 \cdot 2 \cdot 2 \cdot 2 + 0] = 12; \quad (1/2)[4 \cdot 3 \cdot 3 \cdot 3 + 0] = 54.$$

9. Triangular Figure:

$$(a) \quad G = \{\pi_0, \pi_1, \pi_2\} \quad (1/3)[2^4 + 2^2 + 2^2] = 8$$

$$(b) \quad G = \{\pi_0, \pi_1, \pi_2, r_1, r_2, r_3\} \quad (1/6)[2^4 + 2^2 + 2^2 + 3(2^3)] = 8$$

Square Figure:

$$(a) \quad G = \{\pi_0, \pi_1, \pi_2, \pi_3\} \quad (1/4)[2^5 + 2(2^2) + 2^3] = 12$$

$$(b) \quad G = \{\pi_0, \pi_1, \pi_2, \pi_3, r_1, r_2, r_3, r_4\} \quad (1/8)[2^5 + 2(2^2) + 2^3 + 2(2^3) + 2(2^4)] = 12$$

$$10. \quad G = \{\pi_0, \pi_1, \pi_2, \pi_3\} \quad (1/4)[4^5 + 2(4^2) + 4^3] = 280$$

$$(1/4)[4(3^4) + 2(4)(3) + 4(3^2)] = 96$$

$$11. \quad (a) \quad 140 \qquad (b) \quad 102$$

$$12. \quad (a) \quad G = \{\pi_0, \pi_1, \pi_2, \pi_3\} \quad (1/4)[2^{16} + 2(2^4) + 2^8] = 16456$$

$$(b) \quad G = \{\pi_0, \pi_1, \pi_2, \pi_3, r_1, r_2, r_3, r_4\}$$

$$(1/8)[2^{16} + 2(2^4) + 2^8 + 2(2^8) + 2(2^{10})] = 8548$$

$$13. \quad G = \{\pi_i | 0 \leq i \leq 6\}, \text{ where } \pi_i \text{ is the (clockwise) rotation through } i \cdot (360^\circ/7).$$

$$(1/7)[3^7 + 6(3)] = 315$$

14. (a) If  $e$  is the identity of  $G$ , then  $e^*(x) = x$ , so  $H = \{\pi \in G | \pi^*(x) = x\} \neq \emptyset$ . If  $\pi_1, \pi_2 \in G$  and  $\pi_1^*(x) = x = \pi_2^*(x)$ , then  $\pi_1^* \pi_2^*(x) = x = (\pi_1 \pi_2)^*(x)$ , so  $\pi_1 \pi_2 \in H$ . Also, if  $\pi_1^*(x) = x$ , then  $(\pi_1^*)^{-1}(x) = x = (\pi_1^{-1})^*(x)$ , so  $\pi_1 \in H \implies \pi_1^{-1} \in H$  and, consequently,  $H$  is a subgroup of  $G$ .

(b)  $C_1$ : The subgroup is  $\{\pi_0, r_1\}$

$C_{15}$ : The subgroup is  $\{\pi_0, r_3\}$

Section 16.11

$$1. \quad (a) \quad (1/4)[5^4 + 5^2 + 2(5)] = 165$$

$$(b) \quad (1/8)[5^4 + 5^2 + 2(5) + 2(5^2) + 2(5^3)] = 120$$

2. (a)  $(1/5)[5^5 + 4(5)] = 629$   
 (b)  $(1/10)[5^5 + 4(5) + 5(5^3)] = 377$

3. (Triangular Figure):

- (a)  $G = \{\pi_0, \pi_1, \pi_2\} \quad (1/3)[4^4 + 2(4^2)] = 96$   
 (b)  $G = \{\pi_0, \pi_1, \pi_2, r_1, r_2, r_3\} \quad (1/6)[4^4 + 2(4^2) + 3(4^3)] = 80$

(Square Figure):

- (a)  $G = \{\pi_0, \pi_1, \pi_2, \pi_3\}, \quad (1/4)[4^5 + 2(4^2) + 4^3] = 280$   
 (b)  $G = \{\pi_0, \pi_1, \pi_2, \pi_3, r_1, r_2, r_3, r_4\} \quad (1/8)[4^5 + 2(4^2) + 4^3 + 2(4^3) + 2(4^4)] = 220$

(Hexagonal Figure):

- (a)  $G = \{\pi_0, \pi_1\}$  where  $\pi_i$  is the rotation through  $i \cdot 180^\circ$ ,  $i = 0, 1$ .  
 $(1/2)[4^9 + 4^5] = 131,584$   
 (b)  $G = \{\pi_0, \pi_1, r_1, r_2\}$  where  $r_1(r_2)$  is the vertical (horizontal) reflection.  
 $(1/4)[4^9 + 4^5 + 4^5 + 4^7] = 70,144$
4. (a)  $(1/12)[3^6 + 2(3) + 2(3^2) + 4(3^3) + 3(3^4)] = 92$   
 (b)  $(1/12)[m^6 + 2m + 2m^2 + 4m^3 + 3m^4]$  is the number of ways to  $m$ -color the vertices of a regular hexagon that is free to move in space.
5. (a)  $(1/6)[5^6 + 2(5) + 2(5^2) + 5^3] = 2635$   
 (b)  $(1/12)[5^6 + 2(5) + 2(5^2) + 4(5^3) + 3(5^4)] = 1505$   
 (c)

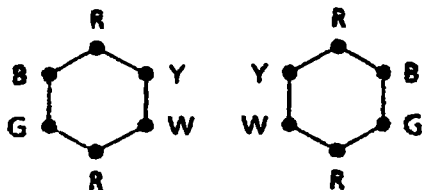

6. (Triangular Figure):

- (a)  $G = \{\pi_0, \pi_1, \pi_2\} \quad (1/3)[3^6 + 2(3^2)] = 249$   
 (b)  $G = \{\pi_0, \pi_1, \pi_2, r_1, r_2, r_3\} \quad (1/6)[3^6 + 2(4^2) + 3(3^4)] = 165$

(Square Figure):

- (a)  $G = \{\pi_0, \pi_1, \pi_2, \pi_3\} \quad (1/4)[3^8 + 2(3^2) + 3^4] = 1665$   
 (b)  $G = \{\pi_0, \pi_1, \pi_2, \pi_3, r_1, r_2, r_3, r_4\} \quad (1/8)[3^8 + 2(3^2) + (3^4) + 4(3^5)] = 954$

(Hexagonal Figure):

- (a)  $G = \{\pi_0, \pi_1\} \quad (1/2)[3^{14} + 3^7] = 2,392,578$   
 (b)  $G = \{\pi_0, \pi_1, r_1, r_2\} \quad (1/4)[3^{14} + 3^7 + 3^9 + 3^8] = 1,202,850$

7. (a)  $(1/8)[3^4 + 2(3) + 3^2 + 2(3^3) + 2(3^2)] = 21$   
 (b)  $(1/8)[3^8 + 2(3^2) + 3^4 + 2(3^5) + 2(3^5)] = 954$

(c) No,  $k = 21$ ,  $m = 21$ , so  $km = 441 \neq 954 = n$ . Here the location of a certain edge must be considered relative to the location of the vertices.

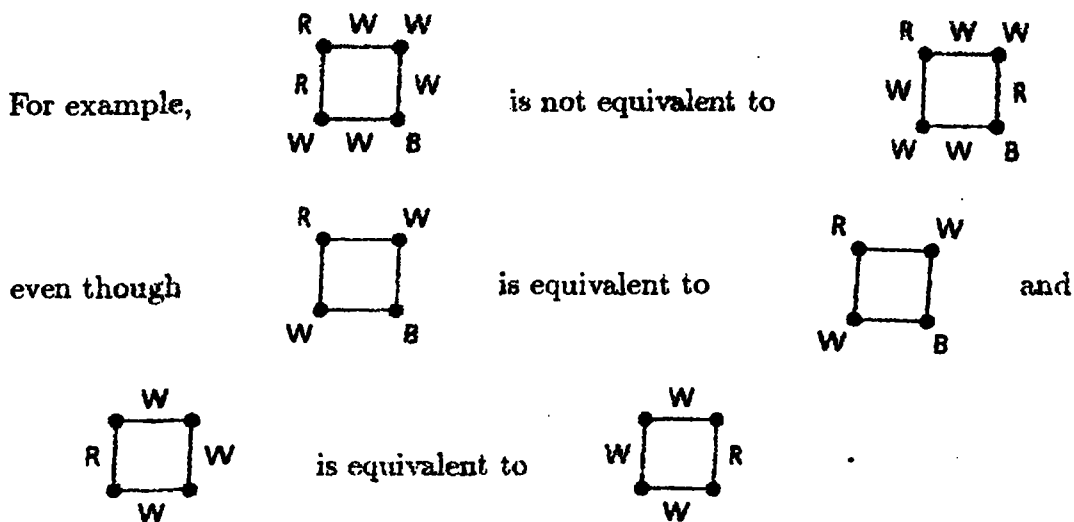

### Section 16.12

1. (a) (i)  $(1/4)[(r+w)^4 + 2(r^4 + w^4) + (r^2 + w^2)^2] = r^4 + w^4 + r^3w + 2r^2w^2 + rw^3$   
 (ii)  $(1/8)[(r+w)^4 + 2(r^4 + w^4) + 3(r^2 + w^2)^2 + 2(r+w)^2(r^2 + w^2)] = r^4 + w^4 + r^3w + 2r^2w^2 + rw^3$
- (b) (i)  $(1/4)[(r+b+w)^4 + 2(r^4 + b^4 + w^4) + (r^2 + b^2 + w^2)^2]$   
 (ii)  $(1/8)[(r+b+w)^4 + 2(r^4 + b^4 + w^4) + 3(r^2 + b^2 + w^2)^2 + 2(r+b+w)^2(r^2 + b^2 + w^2)]$

2. The cycle structure representations for the group elements are as follows:

- (1)  $x_1^5$  for the identity
- (2)  $x_5$  for the four (non-identity) rotations
- (3)  $x_1x_2^2$  for the five reflections.

The pattern inventory is  $(1/10)[(r+b+w)^5 + 4(r^5 + b^5 + w^5) + 5(r+b+w)(r^2 + b^2 + w^2)^2]$ .

For three red vertices we consider the coefficients of the summands that include  $r^3$ :

$$(r+b+w)^5: \binom{5}{3,1,1} + \binom{5}{3,2,0} + \binom{5}{3,0,2} = 40$$

$$(r+b+w)(r^2 + b^2 + w^2)^2: \binom{2}{1,1,0} + \binom{2}{1,0,1} = 4$$

The answer is  $(1/10)[40 + 5(4)] = 6$ .

For the two red, one white, and two blue vertices we consider

$$(r+b+w)^5: \binom{5}{2,1,2} = 30$$

$$(r+b+w)(r^2 + b^2 + w^2)^2: 2$$

The answer is  $(1/10)[30 + 5(2)] = 4$

3. (a) (See Example 16.35)

Rigid Motion	Cycle Structure Representation
(1) Identity	$x_1^6$
(2) Rotation through $90^\circ$	$x_1^2 x_4$
Rotation through $180^\circ$	$x_1^2 x_2^2$
Rotation through $270^\circ$	$x_1^2 x_4$
(3) Rotations of $180^\circ$	$x_2^3$
(4) Rotations of $120^\circ$	$x_3^2$

There are then  $(1/24)[2^6 + 6(2^3) + 3(2^4) + 6(2^3) + 8(2^2)] = 10$  distinct 2-colorings of the faces of the cube.

(b)  $(1/24)[(r+w)^6 + 6(r+w)^2(r^4+w^4) + 3(r+w)^2(r^2+w^2)^2 + 6(r^2+w^2)^3 + 8(r^3+w^3)^2]$

(c) For three red and three white faces we consider the coefficients of the summands that involve  $r^3w^3$ :

$$\begin{array}{ll} (r+w)^6 : & \binom{6}{3} = 20 \\ 3(r+w)^2(r^2+w^2)^2 : & 12 \\ 8(r^3+w^3)^2 : & 16 \end{array}$$

The answer is  $(1/24)[20 + 12 + 16] = 2$

4.  $(36) - (1/12)[3^4 + 8(3^2) + 3(3^2)] = 36 - (1/12)[180] = 21$  compounds have at least one bromine atom.

For the compounds with exactly three hydrogen atoms we need the coefficients of  $w^3x$  and  $w^3y$  in the pattern inventory.

$$(w+x+y+z)^4 : \quad \binom{4}{3,1,0,0} + \binom{4}{3,0,1,0} = 8$$

$$8(w+x+y+z)(w^3+x^3+y^3+z^3) : \quad 8(1+1) = 16$$

The answer is  $(1/12)[8 + 16] = 2$

5. Let  $g$  denote green and  $y$  gold.

(Triangular Figure):  $(1/6)[(g+y)^4 + 2(g+y)(g^3+y^3) + 3(g+y)^2(g^2+y^2)]$

(Square Figure):  $(1/8)[(g+y)^5 + 2(g+y)(g^4+y^4) + (g+y)(g^2+y^2)^2 + 2(g+y)(g^2+y^2)^2 + 2(g+y)^3(g^2+y^2)]$

(Hexagonal Figure):  $(1/4)[(g+y)^9 + (g+y)(g^2+y^2)^4 + (g+y)(g^2+y^2)^4 + (g+y)^5(g^2+y^2)^2]$ .

6. Here  $G = \{\pi_i | 0 \leq i \leq 6\}$  where  $\pi_i$  is a clockwise rotation through  $i \cdot (360^\circ/7)$ .

(a) Denote the colors by  $b$ : black;  $r$ : brown; and  $w$ : white.

The pattern inventory is  $(1/7)[(b+r+w)^7 + 6(b^7+r^7+w^7)]$ . In  $(b+r+w)^7$  the coefficient

of  $b^3r^2w^2$  is  $\binom{7}{3,2,2}$ , so the answer is  $(1/7)\binom{7}{3,2,2} = 30$ .

(b)  $(1/7)[7 \text{ (for } w^7) + \binom{7}{5,1,1} \text{ (for } w^5br) + \binom{7}{3,2,2} \text{ (for } w^3b^2r^2) + \binom{7}{1,3,3} \text{ (for } wb^3r^3)] = (1/7)[7 + 42 + 210 + 140] = 57$

(c) For  $n \in \mathbb{Z}^+$ ,  $(1/7)[n^7 + 6n]$  is the number of ways to  $n$ -color the seven horses on the carousel. Since this is an integer, 7 divides  $(n^7 + 6n)$ .

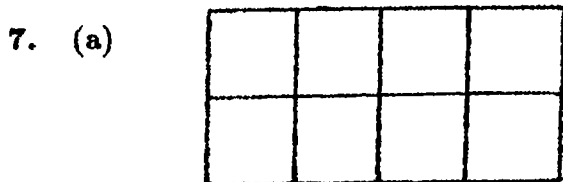

Here  $G = \{\pi_0, \pi_1\}$ , where  $\pi_1$  denotes the  $180^\circ$  rotation.

$(1/2)[2^8 + 2^4] = 136$  distinct ways to 2-color the squares of the chessboard.

(b)  $(1/2)[(r + w)^8 + (r^2 + w^2)^4]$

(c) Four red and four white faces:  $(1/2)[\binom{8}{4} + \binom{4}{2}] = 38$

Six red and two white faces:  $(1/2)[\binom{8}{6} + \binom{4}{1}] = 16$

8. Here  $G = \{\pi_i | 0 \leq i \leq 3\}$  where  $\pi_i$  is a (clockwise) rotation through  $i(90^\circ)$ .

(a)  $(1/4)[2^8 + 2(2^2) + 2^4] = 70$

(b)  $(1/4)[3^8 + 2(3^2) + 3^4] = 1665$

(c) For the pattern inventory denote the colors as follows:  $b$ : black;  $g$ : gold; and  $u$ : blue. Then the pattern inventory is given by  $(1/4)[(b + g + u)^8 + 2(b^4 + g^4 + u^4)^2 + (b^2 + g^2 + u^2)^4]$ .

For four black, two gold, and two blue regions we need the coefficient of  $b^4g^2u^2$  in the pattern inventory. This is  $(1/4)[\binom{8}{4,2,2} + \binom{4}{2,1,1}] = 108$ .

9. Let  $c_1, c_2, \dots, c_m$  denote the  $m$  colors. Since the term  $(c_1 + c_2 + \dots + c_m)^n$  is involved in the pattern inventory, there are  $\binom{m+n-1}{n}$  distinct summands.

### Supplementary Exercises

1. (a) Since  $f(e_G) = e_H$ , it follows that  $e_G \in K$  and  $K \neq \emptyset$ . If  $x, y \in K$ , then  $f(x) = f(y) = e_H$  and  $f(xy) = f(x)f(y) = e_H e_H = e_H$ , so  $xy \in K$ . Also, for  $x \in K$ ,  $f(x^{-1}) = [f(x)]^{-1} = e_H^{-1} = e_H$ , so  $x^{-1} \in K$ . Hence  $K$  is a subgroup of  $G$ .

(b) If  $x \in K$ , then  $f(x) = e_H$ . For all  $g \in G$ ,  $f(gxg^{-1}) = f(g)f(x)f(g^{-1}) = f(g)e_H f(g^{-1}) = f(g)f(g^{-1}) = f(gg^{-1}) = f(e_G) = e_H$ .

Hence, for all  $x \in K, g \in G$ , we find that  $gxg^{-1} \in K$ .

2. Let  $+$  denote the operation in  $G, H$ , and  $K$ .

Let  $S = \{(h, 0) | h \in H\}$ . Here  $0$  is the identity for  $H$  (and  $K$ ) and  $(0, 0)$  is the identity in  $G$ .  $S$  is a nonempty subset of  $G$ .

The function  $f : G \rightarrow G$  defined by  $f(h, k) = (h, 0)$  is a homomorphism with  $f(G) = S$ , so by part (d) of Theorem 16.5  $S$  is a subgroup of  $G$ . The function  $g : S \rightarrow H$  defined by  $g(h, 0) = h$  provides an isomorphism between  $S$  and  $H$ .

In like manner,  $\{(0, k) | k \in K\}$  is a subgroup of  $G$  that is isomorphic to  $K$ .

3. Let  $a, b \in G$ . Then  $a^2b^2 = ee = e = (ab)^2 = abab$ . But  $a^2b^2 = abab \implies aabb = abab \implies ab = ba$ , so  $G$  is abelian.
4. Since  $G$  has even order,  $G - \{e\}$  is odd. For each  $g \in G, g \neq e$ , if  $g \neq g^{-1}$ , remove  $\{g, g^{-1}\}$  from consideration. As we continue this process we must get to at least one element  $a \in G$  where  $a = a^{-1}$ .
5. Let  $G = \langle g \rangle$  and let  $h = f(g)$ . If  $h_1 \in H$ , then  $h_1 = f(g^n)$  for some  $n \in \mathbb{Z}$ , since  $f$  is onto. Therefore,  $h_1 = f(g^n) = [f(g)]^n = h^n$ , and  $H = \langle h \rangle$ .
6. (a) Since  $(1, 0) \oplus (0, 1) = (1, 1)$ , it follows that  $(1, 0) \oplus (0, 1) \oplus (1, 1) = (1, 1) \oplus (1, 1) = (0, 0)$ .

(b) Here we have  $((1, 0, 0) \oplus (0, 1, 1)) \oplus ((0, 1, 0) \oplus (1, 0, 1)) \oplus ((0, 0, 1) \oplus (1, 1, 0)) \oplus (1, 1, 1) = (1, 1, 1) \oplus (1, 1, 1) \oplus (1, 1, 1) \oplus (1, 1, 1) = (0, 0, 0)$ .

(c) Let  $n \in \mathbb{Z}^+, n > 1$ . Consider the group  $(\mathbb{Z}_2 \times \mathbb{Z}_2 \times \dots \times \mathbb{Z}_2, \oplus)$ , where we have  $n$  copies of  $\mathbb{Z}_2$ , and the group operation  $\oplus$  is componentwise addition modulo 2. The sum of all the nonzero (or non-identity) elements in this group is  $(0, 0, \dots, 0)$ , the identity element of the group.

Proof: In this group there are  $2^n - 2$  elements where each such element contains at least one 0 and at least one 1. These  $2^n - 2$  elements can be considered in  $(1/2)(2^n - 2) = 2^{n-1} - 1$  pairs  $x, y$  where  $x \oplus y = (1, 1, \dots, 1)$ , the group element where all  $n$  components are 1. Therefore the sum of these  $2^n - 2$  elements results in  $2^{n-1} - 1$  summands of  $(1, 1, \dots, 1)$ , and this odd number of summands yields  $(1, 1, \dots, 1)$ . When we add this result to the element  $(1, 1, \dots, 1)$  we conclude that the sum of all the nonzero elements in this group is the group identity.

7. Proof: For all  $a, b \in G$ ,

$$(a \circ a^{-1}) \circ b^{-1} \circ b = b \circ b^{-1} \circ (a^{-1} \circ a) \implies a \circ a^{-1} \circ b = b \circ a^{-1} \circ a \implies a \circ b = b \circ a,$$

and so it follows that  $(G, \circ)$  is an abelian group.

8. For  $i = 0$  we find that  $n + 1$  is in a cycle (of length 1) by itself. Here we have  $Q(n, k)$  permutations.

Now let  $i = 1$ . Here  $n + 1$  is in a cycle of length 2. The other element can be selected in  $n = \binom{n}{1}$  ways, and we have  $\binom{n}{1}Q(n - 1, k)$  permutations.

When  $i = 2$ , then  $n + 1$  is in a cycle of length 3. The other two elements can be selected in  $\binom{n}{2}$  ways, and these three elements can be arranged in a cycle of length three in  $2!$  ways. This gives us the  $\binom{n}{2}2!Q(n - 2, k)$  permutations of  $1, 2, \dots, n + 1$  represented as a product of disjoint cycles of length at most  $k$ , where  $n + 1$  is in a cycle of length 3.

In general, for  $i = t - 1$ , where  $1 \leq t \leq k$ , we find  $n + 1$  in a cycle of length  $t$ . The other  $t - 1$  elements can be selected in  $\binom{n}{t-1}$  ways, and then these  $t$  elements can be arranged in a cycle of length  $t$  in  $(t - 1)!$  ways. Then  $\binom{n}{t-1}(t - 1)!$  counts the permutations of  $1, 2, 3, \dots, n + 1$  represented as a product of disjoint cycles of length at most  $k$ , where  $n + 1$  is in a cycle of length  $t$ .

We have counted the same set of permutations in two ways, so it follows that

$$Q(n + 1, k) = \sum_{i=0}^{k-1} \binom{n}{i} (i!) Q(n - i, k).$$

9. (a) Consider a permutation  $\sigma$  that is counted in  $P(n + 1, k)$ . If  $(n + 1)$  is a cycle (of length 1) in  $\sigma$ , then  $\sigma$  (restricted to  $\{1, 2, \dots, n\}$ ) is counted in  $P(n, k - 1)$ . Otherwise, consider any permutation  $\tau$  that is counted in  $P(n, k)$ . For each cycle of  $\tau$ , say  $(a_1 a_2 \dots a_r)$ , there are  $r$  locations in which to place  $n + 1$  - (1) Between  $a_1$  and  $a_2$ ; (2) Between  $a_2$  and  $a_3$ ;  $\dots$ ;  $(r - 1)$  Between  $a_{r-1}$  and  $a_r$ ; and  $(r)$  Between  $a_r$  and  $a_1$ . Hence there are  $n$  locations, in total, to locate  $n + 1$  in  $\tau$ . Consequently,  $P(n + 1, k) = P(n, k - 1) + nP(n, k)$ .

(b)  $\sum_{k=1}^n P(n, k)$  counts all of the permutations in  $S_n$ , which has  $n!$  elements.

10. (a) (i) For all  $\sigma, \tau \in S_n$  and  $1 \leq i \leq n$ ,  $|\sigma(i) - \tau(i)| \geq 0$ , so  $d(\sigma, \tau) \geq 0$ .  
(ii)  $d(\sigma, \tau) = 0 \iff \max_{1 \leq i \leq n} |\sigma(i) - \tau(i)| = 0, 1 \leq i \leq n \iff |\sigma(i) - \tau(i)| = 0, 1 \leq i \leq n \iff \sigma(i) = \tau(i), 1 \leq i \leq n \iff \sigma = \tau$ .  
(iii)  $d(\sigma, \tau) = \max\{|\sigma(i) - \tau(i)| \mid 1 \leq i \leq n\} = \max\{|\tau(i) - \sigma(i)| \mid 1 \leq i \leq n\} = d(\tau, \sigma)$   
(iv) Let  $d(\rho, \tau) = |\rho(i) - \tau(i)|$  for some  $1 \leq i \leq n$ . Then  $|\rho(i) - \tau(i)| = |(\rho(i) - \sigma(i)) + (\sigma(i) - \tau(i))| \leq |\rho(i) - \sigma(i)| + |\sigma(i) - \tau(i)| \leq d(\rho, \sigma) + d(\sigma, \tau)$ .

(b) Since  $d(\pi, \epsilon) = \max\{|\pi(i) - i| \mid 1 \leq i \leq n\}$ , it follows that  $d(\pi, \epsilon) \leq 1 \implies \pi(n) = n$  or  $\pi(n) = n - 1$ .

(c) If  $\pi(n) = n$  then  $\pi$  restricted to  $\{1, 2, 3, \dots, n - 1\}$  is also a permutation. Hence we may regard  $\pi$  as an element of  $S_{n-1}$ , with  $d(\pi, \epsilon) \leq 1$  ( $\epsilon$  in  $S_{n-1}$ ), and there are  $a_{n-1}$  such permutations. Should  $\pi(n) = n - 1$ , then we must also have  $\pi(n - 1) = n$ . Then  $\pi$  restricted to  $\{1, 2, 3, \dots, n - 2\}$  is a permutation. Regarding  $\pi$  as an element

of  $S_{n-2}$  with  $d(\pi, \epsilon) \leq 1$  ( $\epsilon$  in  $S_{n-2}$ ), there are  $a_{n-2}$  such permutations. Therefore,  $a_n = a_{n-1} + a_{n-2}$ ,  $n \geq 2$ ,  $a_1 = 1$ ,  $a_2 = 2$  ( $a_0 = 1$ ), and  $a_n = F_{n+1}$ , the  $(n+1)$ st Fibonacci number.

11. (a) Suppose that  $n$  is composite. We consider two cases.

(1)  $n = m \cdot r$ , where  $1 < m < r < n$ : Here  $(n-1)! = 1 \cdot 2 \cdots (m-1) \cdot m \cdot (m+1) \cdots$

$(r-1) \cdot r \cdot (r+1) \cdots (n-1) \equiv 0 \pmod{n}$ . Hence  $(n-1)! \not\equiv -1 \pmod{n}$ .

(2)  $n = q^2$ , where  $q$  is a prime: If  $(n-1)! \equiv -1 \pmod{n}$  then  $0 \equiv q(n-1)! \equiv q(-1) \equiv n - q \not\equiv 0 \pmod{n}$ . So in this case we also have  $(n-1)! \not\equiv -1 \pmod{n}$ .

(b) From Wilson's Theorem, when  $p$  is an odd prime, we find that

$$-1 \equiv (p-1)! \equiv (p-3)!(p-2)(p-1) \equiv (p-3)!(p^2 - 3p + 2) \equiv 2(p-3)! \pmod{p}.$$

12.  $G = \{\pi_0, \pi_1, \pi_2, \pi_3\}$

(a)  $(1/4)[5^8 + 5^2 + 5^4 + 5^2] = 97,825$

(b) Here four colors are actually used. Nicole can select four colors in  $\binom{5}{4} = 5$  ways. For one selection of four colors let  $c_i, 1 \leq i \leq 4$ , denote that the  $i$ -th color is not used. Then using the principle of inclusion and exclusion we have

$$N = (1/4)[4^8 + 2(4^2) + 4^4] = 16,456$$

$$N(c_i) = (1/4)[3^8 + 2(3^2) + 3^4] = 1665, 1 \leq i \leq 4$$

$$N(c_i c_j) = (1/4)[2^8 + 2(2^2) + 2^4] = 70, 1 \leq i < j \leq 4$$

$$N(c_i c_j c_k) = (1/4)[1^8 + 2(1^2) + 1^4] = 1, 1 \leq i < j < k \leq 4$$

$$N(c_1 c_2 c_3 c_4) = 0$$

$$N(\bar{c}_1 \bar{c}_2 \bar{c}_3 \bar{c}_4) = N - S_1 + S_2 - S_3 + S_4 = 16,456 - \binom{4}{1}(1665) + \binom{4}{2}(70) - \binom{4}{3}(1) + 0 = 10,212.$$

The answer then is  $(5)(10,212) = 51,060$ .

CHAPTER 17  
FINITE FIELDS AND  
COMBINATORIAL DESIGNS

**Section 17.1**

1.  $f(x) + g(x) = 2x^4 + (2 + 3)x^3 + (3 + 5)x^2 + (1 + 6)x + (4 + 1) = 2x^4 + 5x^3 + 8x^2 + 7x + 5 = 2x^4 + 5x^3 + x^2 + 5$

$$f(x) - g(x) = 2x^4 + (2 - 3)x^3 + (3 - 5)x^2 + (1 - 6)x + (4 - 1) = 2x^4 + (-1)x^3 + (-2)x^2 + (-5)x + 3 = 2x^4 + 6x^3 + 5x^2 + 2x + 3$$

$$f(x)g(x) = (2)(3)x^7 + [(2)(5) + (2)(3)]x^6 + [(2)(6) + (2)(5) + (3)(3)]x^5 + [(2)(1) + (2)(6) + (3)(5) + (1)(3)]x^4 + [(2)(1) + (3)(6) + (1)(5) + (4)(3)]x^3 + [(3)(1) + (1)(6) + (4)(5)]x^2 + [(1)(1) + (4)(6)]x + 4 = 6x^7 + 16x^6 + 31x^5 + 32x^4 + 37x^3 + 29x^2 + 25x + 4 = 6x^7 + 2x^6 + 3x^5 + 4x^4 + 2x^3 + x^2 + 4x + 4.$$

2. There are four such polynomials:

(1)  $x^2$                       (2)  $x^2 + x$                       (3)  $x^2 + 1$                       (4)  $x^2 + x + 1$

3.  $(10)(11)^2$ ;  $(10)(11)^3$ ;  $(10)(11)^4$ ;  $(10)(11)^n$

4. (a)  $f(x) = 4x + 8$ ,  $g(x) = 3x^2$   
(b)  $h(x) = 4x^5 + x$ ,  $k(x) = 3x^2$

5. (Theorem 17.1) We shall prove one of the distributive laws. Let  $f(x) = \sum_{i=0}^n a_i x^i$ ,  $g(x) = \sum_{j=0}^m b_j x^j$ ,  $h(x) = \sum_{k=0}^p c_k x^k$ , where  $m \geq p$ . For  $0 \leq t \leq m + n$ , the coefficient of  $x^t$  in  $f(x)[g(x) + h(x)]$  is  $\sum a_i(b_j + c_j)$  where the sum is taken over all  $0 \leq i \leq n$ ,  $0 \leq j \leq m$  with  $i + j = t$ . But this is the same as  $(\sum a_i b_j) + (\sum a_i c_j)$ , for  $0 \leq i \leq n$ ,  $0 \leq j \leq m$ ,  $i + j = t$ , because  $a_i(b_j + c_j) = a_i b_j + a_i c_j$  in ring  $R$ , and this is the coefficient of  $x^t$  in  $f(x)g(x) + f(x)h(x)$ .

(Corollary 17.1)

(a) Let  $f(x) = \sum_{i=0}^n a_i x^i$ ,  $g(x) = \sum_{j=0}^m b_j x^j$ . For all  $0 \leq t \leq m + n$  the coefficient of  $x^t$  in  $f(x)g(x)$  is  $\sum_{i+j=t} a_i b_j = \sum_{i+j=t} b_j a_i$  (since  $R$  is commutative), and this last summation is the coefficient of  $x^t$  in  $g(x)f(x)$ . Hence,  $f(x)g(x) = g(x)f(x)$  and  $R[x]$  is commutative.

(b) Let 1 denote the unity of  $R$ . Then 1 or  $1x^0$  is the unity in  $R[x]$ .

(c) Let  $R$  be an integral domain and let  $f(x) = \sum_{i=0}^n a_i x^i$ ,  $g(x) = \sum_{j=0}^m b_j x^j$  with  $a_n \neq 0$ ,  $b_m \neq 0$ . If  $f(x)g(x) = 0$ , then  $a_n b_m = 0$  contradicting  $R$  as an integral domain. Conversely, if  $R[x]$  is an integral domain and  $a, b \in R$  with  $a \neq 0$  and  $b \neq 0$ , then  $ab = (ax^0)(bx^0) \neq 0$  and  $R$  is an integral domain.

6. (a)  $q(x) = x + 5$   $r(x) = 25x^3 - 9x^2 - 30x - 3$   
 (b)  $q(x) = x^2 + x$   $r(x) = 1$   
 (c)  $q(x) = x^2 + 4x + 2$   $r(x) = x + 2$
7. (a) and (b)  $f(x) = (x^2 + 4)(x - 2)(x + 2)$ ; the roots are  $\pm 2$ .  
 (c)  $f(x) = (x + 2i)(x - 2i)(x - 2)(x + 2)$ ; the roots are  $\pm 2, \pm 2i$   
 (d) (a)  $f(x) = (x^2 - 5)(x^2 + 5)$ ; no rational roots  
 (b)  $f(x) = (x - \sqrt{5})(x + \sqrt{5})(x^2 + 5)$ ; the roots are  $\pm\sqrt{5}$   
 (c)  $f(x) = (x - \sqrt{5})(x + \sqrt{5})(x - \sqrt{5}i)(x + \sqrt{5}i)$ ; the roots are  $\pm\sqrt{5}, \pm i\sqrt{5}$
8. (a) 0, 2, 6, 8 (b)  $x(x + 4) = (x - 0)(x - 8) = f(x) = (x - 2)(x - 6)$   
 (c) No -  $\mathbf{Z}_{12}$  is *not* a field.
9. (a)  $f(3) = 8060$  (b)  $f(1) = 1$  (c)  $f(-9) = f(2) = 6$
10. (a)  $f(x) = x^3 + 5x^3 + 2x + 6 = (x - 1)(x - 3)(x - 5)$   
 (b)  $f(x) = x^7 - x = x(x - 1)(x - 2)(x - 3)(x - 4)(x - 5)(x - 6)$

11. 4; 6;  $p - 1$

12. (a) If  $x - 1$  is a factor of  $f(x)$ , then 1 is a root of the polynomial. Consequently,  $0 = f(1) = a_n + a_{n-1} + \dots + a_2 + a_1 + a_0$ .

Conversely,  $a_n + a_{n-1} + \dots + a_2 + a_1 + a_0 = 0 \Rightarrow$

$$0 = a_n(1)^n + a_{n-1}(1)^{n-1} + \dots + a_2(1)^2 + a_1(1)^1 + a_0(1)^0 = f(1) \Rightarrow$$

1 is a root of  $f(x) \Rightarrow x - 1$  is a factor of  $f(x)$ .

(b) If  $x + 1$  is a factor of  $f(x)$ , then  $-1$  is a root of  $f(x)$ . Therefore,  $0 = a_n(-1)^n + a_{n-1}(-1)^{n-1} + a_{n-2}(-1)^{n-2} + a_{n-3}(-1)^{n-3} + \dots + a_3(-1)^3 + a_2(-1)^2 + a_1(-1) + a_0$ . Since  $n$  is even it follows that

$$0 = a_n - a_{n-1} + a_{n-2} - a_{n-3} + \dots - a_3 + a_2 - a_1 + a_0,$$

so  $a_n + a_{n-2} + \dots + a_2 + a_0 = a_{n-1} + a_{n-3} + \dots + a_3 + a_1$ .

Conversely, under the conditions given,

$$a_n + a_{n-2} + \dots + a_2 + a_0 = a_{n-1} + a_{n-3} + \dots + a_3 + a_1 \Rightarrow$$

$$0 = a_n - a_{n-1} + a_{n-2} - a_{n-3} + \dots - a_3 + a_2 - a_1 + a_0 \Rightarrow$$

$$0 = a_n(-1)^n + a_{n-1}(-1)^{n-1} + a_{n-2}(-1)^{n-2} + a_{n-3}(-1)^{n-3} + \dots + a_3(-1)^3 + a_2(-1)^2 + a_1(-1) + a_0 = f(-1) \Rightarrow$$

$-1$  is a root of  $f(x) \Rightarrow x - (-1) = x + 1$  is a factor of  $f(x)$ .

13. Let  $f(x) = \sum_{i=0}^m a_i x^i$  and  $h(x) = \sum_{i=0}^k b_i x^i$ , where  $a_i \in R$  for  $0 \leq i \leq m$ , and  $b_i \in R$  for  $0 \leq i \leq k$ , and  $m \leq k$ . Then  $f(x) + h(x) = \sum_{i=0}^k (a_i + b_i)x^i$ , where  $a_{m+1} = a_{m+2} = \dots = a_k = z$ , the zero of  $R$ , so  $G(f(x) + h(x)) = G(\sum_{i=0}^k (a_i + b_i)x^i) = \sum_{i=0}^k g(a_i + b_i)x^i = \sum_{i=0}^k [g(a_i) + g(b_i)]x^i = \sum_{i=0}^k g(a_i)x^i + \sum_{i=0}^k g(b_i)x^i = G(f(x)) + G(h(x))$ .

Also,  $f(x)h(x) = \sum_{i=0}^{m+k} c_i x^i$ , where  $c_i = a_i b_0 + a_{i-1} b_1 + \dots + a_1 b_{i-1} + a_0 b_i$ , and

$$G(f(x)h(x)) = G\left(\sum_{i=0}^{m+k} c_i x^i\right) = \sum_{i=0}^{m+k} g(c_i)x^i.$$

Since  $g(c_i) = g(a_i)g(b_0) + g(a_{i-1})g(b_1) + \dots + g(a_1)g(b_{i-1}) + g(a_0)g(b_i)$ ,

$$\sum_{i=0}^{m+k} g(c_i)x^i = \left(\sum_{i=0}^m g(a_i)x^i\right)\left(\sum_{i=0}^k g(b_i)x^i\right) = G(f(x)) \cdot G(h(x)).$$

Consequently,  $G : R[x] \rightarrow S[x]$  is a ring homomorphism.

14. If  $f(x)$  is a unit in  $R[x]$  then there exists  $g(x)$  in  $R[x]$  where  $f(x)g(x) = 1$  (the unity of  $R[x]$ ). But  $f(x)g(x) = 1$  and  $R$  an integral domain imply that  $\deg 1 = 0 = \deg f(x)g(x) = \deg f(x) + \deg g(x)$ . So  $\deg f(x) = 0 = \deg g(x)$ , and each of  $f(x), g(x)$  are constants, and consequently units in  $R$ .
15. In  $\mathbf{Z}_4[x]$ ,  $(2x+1)(2x+1) = 1$ , so  $(2x+1)$  is a unit. This does not contradict Exercise 14 because  $(\mathbf{Z}_4, +, \cdot)$  is not an integral domain.
16. If  $a \equiv b \pmod{n}$ , then by mathematical induction it follows that  $a^k \equiv b^k \pmod{n}$  for all  $k \in \mathbf{Z}^+$ . Also,  $c(a^k) \equiv c(b^k) \pmod{n}$  for each  $c \in \mathbf{Z}$ , by the definition of multiplication in  $\mathbf{Z}_n$ . Finally, again by mathematical induction (on the degree of  $f(x)$ ) and the definition of addition in  $\mathbf{Z}_n$ , it follows that  $f(a) \equiv f(b) \pmod{n}$ .
17. First note that for  $f(x) = a_n x^n + a_{n-1} x^{n-1} + \dots + a_2 x^2 + a_1 x + a_0$ , we have  $a_n + a_{n-1} + \dots + a_2 + a_1 + a_0 = 0$  if and only if  $f(1) = 0$ . Since the zero polynomial is in  $S$ , the set  $S$  is not empty. With  $f(x)$  as given here, let  $g(x) = b_m x^m + b_{m-1} x^{m-1} + \dots + b_2 x^2 + b_1 x + b_0 \in S$ . (Here  $m \leq n$ , and for  $m < n$  we have  $b_{m+1} = b_{m+2} = \dots = b_n = 0$ .) Then  $f(1) - g(1) = 0 - 0 = 0$  so  $f(x) - g(x) \in S$ .
- Now consider  $h(x) = \sum_{i=0}^k r_i x^i \in F[x]$ . Here  $h(x)f(x) \in F[x]$  and  $h(1)f(1) = h(1) \cdot 0 = 0$ , so  $h(x)f(x) \in S$ .
- Consequently,  $S$  is an ideal in  $F[x]$ .
18. Let  $f(x), g(x) \in I[x]$  where  $f(x) = \sum_{i=0}^m a_i x^i$ ,  $g(x) = \sum_{j=0}^n b_j x^j$ , and  $a_i \in I$  for  $0 \leq i \leq m$ ,  $b_j \in I$  for  $0 \leq j \leq n$ . Assume  $m \leq n$  and that  $a_{m+1} = a_{m+2} = \dots = a_n = z$ , the zero element of  $R$ . Then  $f(x) - g(x) = \sum_{j=0}^n (a_j - b_j)x^j$ , where  $a_j - b_j \in I$  for  $0 \leq j \leq n$  because  $I$  is an ideal. Now let  $h(x) = \sum_{k=0}^p r_k x^k \in R[x]$ . Then  $h(x)f(x) = \sum_{t=0}^{m+p} c_t x^t$  where  $c_t = r_0 a_t + r_1 a_{t-1} + r_2 a_{t-2} + \dots + r_{t-1} a_1 + r_t a_0$ . Since  $I$  is an ideal of  $R$ ,  $r_0 a_t,$

$r_1 a_{t-1}, r_2 a_{t-2}, \dots, r_{t-1} a_1, r_t a_0 \in I$  and it then follows that  $c_t \in I$  and  $h(x)f(x) \in I[x]$ . In a similar way it follows that  $f(x)h(x) \in I[x]$ . Consequently,  $I[x]$  is an ideal in  $R[x]$ .

## Section 17.2

1. (a)  $x^2 + 3x - 1$  is irreducible over  $\mathbf{Q}$ . Over  $\mathbf{R}, \mathbf{C}$ ,

$$x^2 + 3x - 1 = [x - ((-3 + \sqrt{13})/2)][x - ((-3 - \sqrt{13})/2)].$$

- (b)  $x^4 - 2$  is irreducible over  $\mathbf{Q}$ .

$$\text{Over } \mathbf{R}, x^4 - 2 = (x - \sqrt[4]{2})(x + \sqrt[4]{2})(x^2 + \sqrt{2});$$

$$x^4 - 2 = (x - \sqrt[4]{2})(x + \sqrt[4]{2})(x - \sqrt[4]{2}i)(x + \sqrt[4]{2}i) \text{ over } \mathbf{C}$$

- (c)  $x^2 + x + 1 = (x + 2)(x + 2)$  over  $\mathbf{Z}_3$ . Over  $\mathbf{Z}_5, x^2 + x + 1$  is irreducible;  
 $x^2 + x + 1 = (x + 5)(x + 3)$  over  $\mathbf{Z}_7$ .

- (d)  $x^4 + x^3 + 1$  is irreducible over  $\mathbf{Z}_2$ .

- (e)  $x^3 + 3x^2 - x + 1$  is irreducible over  $\mathbf{Z}_5$ .

2.  $f(x) = (x^2 + 1)^3$

3. Degree 1:  $x; x + 1$

$$\text{Degree 2: } x^2 + x + 1$$

$$\text{Degree 3: } x^3 + x^2 + 1; x^3 + x + 1$$

4.  $f(x) = (2x^2 + 1)(5x^3 - 5x + 3)(4x - 3) = 2(x^2 + 4)(5)(x^3 - x + 2)(4)(x - 6) = 5(x^2 + 4)(x^3 - x + 2)(x - 6)$ , since  $40 = 5$  in  $\mathbf{Z}_7$ .

5.  $7^5$

6. (Theorem 17.7)

(a) Let  $f(x) \in F[x]$  with  $\deg f(x) \leq 1$ . If  $f(x)$  were reducible then  $f(x) = g(x)h(x)$  with  $\deg g(x), h(x) \geq 1$ . Then  $1 \geq \deg f(x) = \deg g(x) + \deg h(x) \geq 2$ .

(b) If  $f(x)$  has a root  $r$  in  $F$  then  $(x - r)$  is a factor of  $f(x)$ . Hence  $f(x) = (x - r)g(x)$  where  $\deg g(x) = 1$  or  $2$ , so  $f(x)$  is reducible. Conversely, for  $f(x)$  reducible,  $f(x) = h(x)k(x)$  where  $\deg h(x), k(x) \geq 1$ . With  $\deg f(x) = 2$  or  $3$ , one of  $h(x), k(x)$  is a first degree (or linear) factor, say  $h(x) = ax + b, a, b \in F, a \neq 0$ . Then  $-b/a$  is a root of  $f(x)$ .

7. (a) Yes, since the coefficients of the polynomials are from a field.

(b)  $h(x)|f(x), g(x) \implies f(x) = h(x)u(x), g(x) = h(x)v(x)$ , for some  $u(x), v(x) \in F[x]$ .  
 $m(x) = s(x)f(x) + t(x)g(x)$  for some  $s(x), t(x) \in F[x]$ , so  
 $m(x) = h(x)[s(x)u(x) + t(x)v(x)]$  and  $h(x)|m(x)$ .

(c) If  $m(x) \nmid f(x)$ , then  $f(x) = q(x)m(x) + r(x)$  where  $r(x) \neq 0$  and  $0 \leq \deg r(x) < \deg m(x)$ .  $m(x) = s(x)f(x) + t(x)g(x)$  so  $r(x) = f(x) - q(x)[s(x)f(x) + t(x)g(x)] = (1 - q(x))s(x)f(x) - q(x)t(x)g(x)$ , so  $r(x) \in S$ . With  $\deg r(x) < \deg m(x)$  we contradict the choice of  $m(x)$ . Hence  $r(x) = 0$  and  $m(x) \mid f(x)$ .

8. (Theorem 17.9)

From the last equation  $r_k(x)$  divides  $r_{k-1}(x)$ . The next to last equation yields  $r_k(x)$  divides  $r_{k-2}(x)$ . Continuing backwards we find  $r_k(x)$  divides  $r_2(x)$  and  $r_1(x)$ , so  $r_k(x)$  divides  $r(x)$ . From the second equation  $r_k(x)$  divides  $f(x)$ ;  $r_k(x)$  then divides  $g(x)$  from the first equation. To establish condition (b) of Definition 17.6, let  $k(x) \in F[x]$  where  $k(x)$  divides  $r(x)$ . From the second equation,  $k(x)$  divides  $r_1(x)$  since it divides  $f(x)$  and  $r(x)$ . Continuing down the list of equations we get to where  $k(x)$  divides  $r_{k-2}(x)$  and  $r_{k-1}(x)$ , and, consequently,  $r_k(x)$ .

(Theorem 17.10)

For all  $f(x) \in F[x]$ ,  $f(x) - f(x) = 0 = 0 \cdot s(x)$ , so  $\mathcal{R}$  is reflexive. To show that  $\mathcal{R}$  is symmetric, let  $f(x), g(x) \in F[x]$  with  $f(x)\mathcal{R}g(x)$ .  $f(x)\mathcal{R}g(x) \implies f(x) - g(x) = t(x)s(x)$ , for some  $t(x) \in F[x] \implies g(x) - f(x) = [-t(x)]s(x)$ ,  $-t(x) \in F[x] \implies g(x)\mathcal{R}f(x)$ , so  $\mathcal{R}$  is symmetric. Finally, let  $f(x), g(x), h(x) \in F[x]$  with  $f(x)\mathcal{R}g(x)$  and  $g(x)\mathcal{R}h(x)$ . Then  $f(x) - g(x) = t(x)s(x)$ ,  $g(x) - h(x) = u(x)s(x)$ , so  $[f(x) - g(x)] + [g(x) - h(x)] = f(x) - h(x) = [t(x) + u(x)]s(x)$  and  $\mathcal{R}$  is transitive.

9. (a) By the long division of polynomials we have

$$x^5 - x^4 + x^3 + x^2 - x - 1 = (x^3 - 2x^2 + 5x - 8)(x^2 + x - 2) + (17x - 17)$$

$$x^2 + x - 2 = (17x - 17)[(1/17)x + (2/17)x],$$

so the gcd of  $f(x), g(x)$  is

$$(x - 1) = (1/17)(x^5 - x^4 + x^3 + x^2 - x - 1) - (1/17)(x^2 + x - 2)(x^3 - 2x^2 + 5x - 8).$$

(b) The gcd is  $1 = (x + 1)(x^4 + x^3 + 1) + (x^3 + x^2 + x)(x^2 + x + 1)$

(c) The gcd is  $x^2 + 2x + 1 = (x^4 + 2x^2 + 2x + 2) + (x + 2)(2x^3 + 2x^2 + x + 1)$

10. If there were, then  $x - a$  would be a factor of both  $f(x)$  and  $g(x)$ , so  $x - a$  would divide the gcd of  $f(x), g(x)$ . This contradicts  $f(x), g(x)$  being relatively prime.

11.  $f(x) = x^3 + 2x^2 + ax - b$

$$g(x) = x^3 + x^2 - bx + a$$

From the Division Algorithm for polynomials we find that  $f(x) = g(x) + r(x)$ , where  $r(x) = x^2 + (a + b)x - (a + b)$ , a polynomial of degree 2.

Since we want  $r(x)$  to be the gcd, we must have  $r(x)$  dividing  $f(x)$ .

Since  $f(x) = r(x)[x + (2 - a - b)] + [(2a + b) - (2 - a - b)(a + b)]x + [-b + (a + b)(2 - a - b)]$ , we must have  $(2a + b) - (2 - a - b)(a + b) = 0$  and  $-b + (a + b)(2 - a - b) = 0$ . Consequently,

$$0 = (2a + b) - (2 - a - b)(a + b) = a^2 + b^2 + 2ab - b$$

$$0 = -b + (a + b)(2 - a - b) = -a^2 - b^2 - 2ab + 2a + b. \text{ So } 2a = 0, \text{ or } a = 0 \text{ and } b^2 - b = 0.$$

There are two solutions:

$$a = 0, b = 0; \quad a = 0, b = 1.$$

12. (a)  $x^2 \equiv x + 1 \pmod{s(x)} \implies x^3 \equiv x^2 + x \equiv 1 \pmod{s(x)} \implies x^4 \equiv x \pmod{s(x)}.$

$$x^4 + x^3 + x + 1 \equiv x + 1 + x + 1 \equiv 0 \pmod{s(x)}, \text{ so } x^4 + x^3 + x + 1 \in [0].$$

(Also note that  $x^4 + x^3 + x + 1 = (x^2 + 1)(x^2 + x + 1).$ )

(b)  $x^3 + x^2 + 1 \in [x + 1]$

(c)  $x^4 + x^3 + x^2 + 1 = x^2(x^2 + x + 1) + 1$ , so  $x^4 + x^3 + x^2 + 1 \in [1].$

13. (a)  $f(x) \equiv f_1(x) \pmod{s(x)} \implies f(x) = f_1(x) + h(x)s(x);$   
 $g(x) \equiv g_1(x) \pmod{s(x)} \implies g(x) = g_1(x) + k(x)s(x)$

Hence  $f(x) + g(x) = f_1(x) + g_1(x) + (h(x) + k(x))s(x)$ , so  $f(x) + g(x) \equiv f_1(x) + g_1(x) \pmod{s(x)}$ , and  $f(x)g(x) = f_1(x)g_1(x) + (f_1(x)k(x) + g_1(x)h(x) + h(x)k(x)s(x)))s(x)$ , so  $f(x)g(x) \equiv f_1(x)g_1(x) \pmod{s(x)}$ .

(b) These properties follow from the corresponding properties for  $F[x]$ . For example, for the distributive law,

$$\begin{aligned} [f(x)][(g(x)) + (h(x))] &= [f(x)][g(x) + h(x)] = [f(x)(g(x) + h(x))] \\ &= [f(x)g(x) + f(x)h(x)] = [f(x)g(x)] + [f(x)h(x)] \\ &= [f(x)][g(x)] + [f(x)][h(x)] \end{aligned}$$

(c) If not, there exists  $g(x) \in F[x]$  where  $\deg g(x) > 0$  and  $g(x)|f(x), s(x)$ . But then  $s(x)$  would be reducible.

(d) A nonzero element of  $F[x]/(s(x))$  has the form  $[f(x)]$  where  $f(x) \neq 0$  and  $\deg f(x) < \deg s(x)$ . With  $f(x), s(x)$  relatively prime, there exist  $r(x), t(x)$  with  $1 = f(x)r(x) + s(x)t(x)$ , so  $1 \equiv f(x)r(x) \pmod{s(x)}$  or  $[1] = [f(x)][r(x)]$ . Hence  $[r(x)] = [f(x)]^{-1}$ .

(e)  $q^n$

14. (a)  $x^2 + 1 = (x + 1)(x + 1)$  in  $\mathbf{Z}_2[x]$

(b)  $[0], [1], [x], [x + 1]$

(c)  $\mathbf{Z}_2[x]/(s(x))$  is not an integral domain since  $[x + 1][x + 1] = [0]$ .

15. (a)  $[x+2][2x+2]+[x+1] = [2x^2+1]+[x+1] = [2x^2+x+2] = [4x+2+x+2] = [2x+1]$  (Note: With  $x^2 + x + 2 \equiv 0 \pmod{s(x)}$ , it follows that  $x^2 \equiv -x - 2 \equiv 2x + 1 \pmod{s(x)}$ .)

(b)  $[2x + 1]^2[x + 2] = [x^2 + x + 1][x + 2] = [x^3 + 2] = [x(2x + 1) + 2] = [2x^2 + x + 2] = [2x + 1]$

(c) Find  $a, b \in \mathbf{Z}_3$  so that  $[2x + 2][ax + b] = [1]$ .

$$[2ax^2 + (2a + 2b)x + 2b] = [1]$$

$$[2a(-x - 2) + (2a + 2b)x + 2b] = [2bx + (2b + 2a)] = [1]$$

$$2b \equiv 0 \pmod{3}, (2b + 2a) \equiv 1 \pmod{3} \implies b \equiv 0 \pmod{3},$$



elements.

23. For  $s(x) = x^3 + x^2 + x + 2 \in \mathbf{Z}_3[x]$  one finds that  $s(0) = 2$ ,  $s(1) = 2$ , and  $s(2) = 1$ . It then follows from part (b) of Theorem 17.7 and parts (b) and (c) of Theorem 17.11 that  $\mathbf{Z}_3[x]/(s(x))$  is a finite field with  $3^3 = 27$  elements.

24. (a)  $h([a + bx]) = h([c + dx]) \Rightarrow a + bi = c + di \Rightarrow a = c$  and  $b = d \Rightarrow a + bx = c + dx \Rightarrow [a + bx] = [c + dx]$ , so  $h$  is one-to-one.

For all  $a + bi \in \mathbf{C}$ , where  $a, b \in \mathbf{R}$ , we find that  $[a + bx] \in \mathbf{R}[x]/(x^2 + 1)$  and  $h([a + bx]) = a + bi$ . Consequently, the function  $h$  is also onto.

Finally, if  $[a + bx], [c + dx] \in \mathbf{R}[x]/(x^2 + 1)$ , then  $h([a + bx] + [c + dx]) = h([(a + bx) + (c + dx)]) = h([(a + c) + (b + d)x]) = (a + c) + (b + d)i = (a + bi) + (c + di) = h([a + bx]) + h([c + dx])$ , so  $h$  preserves the operation of addition.

(b) Let  $u_F, u_K$  denote the unity elements of fields  $F$  and  $K$ , respectively. Then  $g(u_F) = g(u_F \cdot u_F) = g(u_F) \odot g(u_F)$ , so  $g(u_F) \odot u_K = g(u_F) = g(u_F) \odot g(u_F)$ . If  $z_F, z_K$  denote the zero elements of  $F$  and  $K$ , respectively, then  $g(z_F) = z_K$  (from part (a) of Theorem 14.15). Since  $g$  is one-to-one,  $g(u_F) \neq z_K$ , so by cancellation in  $K$  we have  $g(u_F) \odot u_K = g(u_F) \odot g(u_F) \Rightarrow u_K = g(u_F)$ .

Now if  $a \in F$  and  $a \neq z_F$ , then  $a^{-1} \in F$  and  $g(u_F) = g(a \cdot a^{-1}) = g(a) \odot g(a^{-1})$ . But  $g(u_F) = u_K = g(a) \odot [g(a)]^{-1}$  because  $g(a) \in K$ . Since  $g(a) \neq z_K$ , by cancellation in  $K$  we have  $g(a^{-1}) = [g(a)]^{-1}$ .

25. (a) Since  $0 = 0 + 0\sqrt{2} \in \mathbf{Q}[\sqrt{2}]$ , the set  $\mathbf{Q}[\sqrt{2}]$  is nonempty. For  $a + b\sqrt{2}, c + d\sqrt{2} \in \mathbf{Q}[\sqrt{2}]$ , we have

$$(a + b\sqrt{2}) - (c + d\sqrt{2}) = (a - c) + (b - d)\sqrt{2}, \text{ with } (a - c), (b - d) \in \mathbf{Q}; \text{ and}$$

$$(a + b\sqrt{2})(c + d\sqrt{2}) = (ac + 2bd) + (ad + bc)\sqrt{2}, \text{ with } ac + 2bd, ad + bc \in \mathbf{Q}.$$

Consequently, it follows from part (a) of Theorem 14.10 that  $\mathbf{Q}[\sqrt{2}]$  is a subring of  $\mathbf{R}$ .

(b) In order to show that  $\mathbf{Q}[\sqrt{2}]$  is a subfield of  $\mathbf{R}$  we need to find in  $\mathbf{Q}[\sqrt{2}]$  a multiplicative inverse for each nonzero element in  $\mathbf{Q}[\sqrt{2}]$ .

Let  $a + b\sqrt{2} \in \mathbf{Q}[\sqrt{2}]$  with  $a + b\sqrt{2} \neq 0$ . If  $b = 0$ , then  $a \neq 0$  and  $a^{-1} \in \mathbf{Q}$  — and  $a^{-1} + 0 \cdot \sqrt{2} \in \mathbf{Q}[\sqrt{2}]$ . For  $b \neq 0$ , we need to find  $c + d\sqrt{2} \in \mathbf{Q}[\sqrt{2}]$  so that

$$(a + b\sqrt{2})(c + d\sqrt{2}) = 1$$

Now  $(a + b\sqrt{2})(c + d\sqrt{2}) = 1 \Rightarrow (ac + 2bd) + (ad + bc)\sqrt{2} = 1 \Rightarrow ac + 2bd = 1$  and  $ad + bc = 0 \Rightarrow c = -ad/b$  and  $a(-ad/b) + 2bd = 1 \Rightarrow -a^2d + 2b^2d = b \Rightarrow d = b/(2b^2 - a^2)$  and  $c = -a/(2b^2 - a^2)$ . [Note:  $2b^2 - a^2 \neq 0$  because  $\sqrt{2}$  is irrational.]

Consequently,  $(a + b\sqrt{2})^{-1} = [-a/(2b^2 - a^2)] + [b/(2b^2 - a^2)]\sqrt{2}$ , with  $[-a/(2b^2 - a^2)], [b/(2b^2 - a^2)] \in \mathbf{Q}$ . So  $\mathbf{Q}[\sqrt{2}]$  is a subfield of  $\mathbf{R}$ .

(c) Since  $s(x) = x^2 - 2$  is irreducible over  $\mathbf{Q}$  we know from part (b) of Theorem 17.11 that  $\mathbf{Q}[x]/(x^2 - 2)$  is a field.

Define the correspondence  $f : \mathbf{Q}[x]/(x^2 - 2) \rightarrow \mathbf{Q}[\sqrt{2}]$  by

$$f([a + bx]) = a + b\sqrt{2}.$$

By an argument similar to the one given in Example 17.10 and part (a) of Exercise 24 it follows that  $f$  is an isomorphism.

26. (a) Here we want to write  $x^2 + bx + c$  as the product  $(x - r_1)(x - r_2)$  where  $r_1, r_2 \in \mathbf{Z}_p$ . Since  $(x - r_1)(x - r_2) = (x - r_2)(x - r_1)$ , where we may have  $r_1 = r_2$ , here we seek the number of selections of size 2 from the set  $\mathbf{Z}_p = \{0, 1, 2, \dots, p-1\}$ , with repetitions allowed. Consequently, the number of these monic quadratic polynomials is  $\binom{p+2-1}{2} = \binom{p+1}{2} = \frac{1}{2}(p+1)(p) = \frac{1}{2}(p^2 + p)$ .

(b) Since  $ax^2 + bx + c$  is a quadratic polynomial we have  $a \neq 0$ . Then with  $\mathbf{Z}_p$  a field it follows that  $ax^2 + bx + c = a(x^2 + a^{-1}bx + a^{-1}c)$ , so we want to be able to factor the monic quadratic polynomial  $x^2 + a^{-1}bx + a^{-1}c (= x^2 + b_1x + c_1)$  into linear factors. We have returned to part (a) of the problem where we found the answer to be  $\frac{1}{2}(p^2 + p)$ . So here the answer is  $(p-1)\frac{1}{2}(p^2 + p) = \frac{1}{2}p(p^2 - 1)$ , because there are  $p-1$  nonzero choices for  $a$ .

(c) Since there are  $(1)(p)(p) = p^2$  monic quadratic polynomials over  $\mathbf{Z}_p$ , by using the result from part (a) it follows that there are  $p^2 - \frac{1}{2}(p^2 + p) = \frac{1}{2}(p^2 - p)$  irreducible monic quadratic polynomials over  $\mathbf{Z}_p$ .

(d) Here we use the result from part (b), and find that there are  $(p-1)(p)(p) - \frac{1}{2}p(p^2 - 1) = \frac{1}{2}p(p-1)^2$  irreducible quadratic polynomials over  $\mathbf{Z}_p$ .

### Section 17.3

1. (a) 

1	2	3	4
2	1	4	3
4	3	2	1
3	4	1	2

 (b) 

1	2	3	4
3	4	1	2
2	1	4	3
4	3	2	1

 (c) 

1	3	4	2
4	2	1	3
3	1	2	4
2	4	3	1

2. If not, there is an ordered pair  $(j, k)$ ,  $1 \leq j, k \leq n$ , that appears more than once when the Latin squares  $L_1^*, L_2^*$  are superimposed. Let  $\pi_i$  be the permutation of  $\{1, 2, \dots, n\}$  that standardizes  $L_i$  as  $L_i^*$ ,  $i = 1, 2$ . The inverse permutation  $\pi_i^{-1}$ ,  $i = 1, 2$ , changes  $L_i^*$  into  $L_i$ . In this process, the ordered pair  $(\pi_1^{-1}(j), \pi_2^{-1}(k))$  will appear more than once when  $L_1, L_2$  are superimposed. This contradicts  $L_1, L_2$  being an orthogonal pair.

3.  $a_{ri}^{(k)} = a_{rj}^{(k)} \implies f_k f_r + f_i = f_k f_r + f_j \implies f_i = f_j \implies i = j$ .

4. By virtue of Theorem 17.16, each  $4 \times 4$  Latin square, in standard form, is equal to one of these three  $4 \times 4$  Latin squares. In this sense, there are no others.

5.

$$L_3: \begin{array}{ccccc} 4 & 5 & 1 & 2 & 3 \\ 2 & 3 & 4 & 5 & 1 \\ 5 & 1 & 2 & 3 & 4 \\ 3 & 4 & 5 & 1 & 2 \\ 1 & 2 & 3 & 4 & 5 \end{array}$$

$$L_4: \begin{array}{ccccc} 5 & 1 & 2 & 3 & 4 \\ 4 & 5 & 1 & 2 & 3 \\ 3 & 4 & 5 & 1 & 2 \\ 2 & 3 & 4 & 5 & 1 \\ 1 & 2 & 3 & 4 & 5 \end{array}$$

In standard form the Latin squares  $L_i$ ,  $1 \leq i \leq 4$ , become

$$L'_1: \begin{array}{ccccc} 1 & 2 & 3 & 4 & 5 \\ 2 & 3 & 4 & 5 & 1 \\ 3 & 4 & 5 & 1 & 2 \\ 4 & 5 & 1 & 2 & 3 \\ 5 & 1 & 2 & 3 & 4 \end{array}$$

$$L'_2: \begin{array}{ccccc} 1 & 2 & 3 & 4 & 5 \\ 3 & 4 & 5 & 1 & 5 \\ 5 & 1 & 2 & 3 & 4 \\ 2 & 3 & 4 & 5 & 1 \\ 4 & 5 & 1 & 2 & 3 \end{array}$$

$$L'_3: \begin{array}{ccccc} 1 & 2 & 3 & 4 & 5 \\ 4 & 5 & 1 & 2 & 3 \\ 2 & 3 & 4 & 5 & 1 \\ 5 & 1 & 2 & 3 & 4 \\ 3 & 4 & 5 & 1 & 2 \end{array}$$

$$L'_4: \begin{array}{ccccc} 1 & 2 & 3 & 4 & 5 \\ 5 & 1 & 2 & 3 & 4 \\ 4 & 5 & 1 & 2 & 3 \\ 3 & 4 & 5 & 1 & 2 \\ 2 & 3 & 4 & 5 & 1 \end{array}$$

6.  $Z_7 = \{1, 2, 3, \dots, 7\}$ , so  $f_1 = 1$ ,  $f_7 = 7$ , as in the proof of Theorem 17.16. Here there are a total of six  $7 \times 7$  Latin squares  $L_k = (a_{ij}^{(k)})$ ,  $1 \leq k \leq 6$ , where  $a_{ij}^{(k)} = f_k f_i + f_j$ .

For  $k = 1$ ,  $a_{ij}^{(1)} = f_1 f_i + f_j = f_i + f_j$ . This results in the Latin square  $L_1$  (and  $L_1^*$  is  $L_1$  in standard form).

$$L_1: \begin{array}{ccccccc} 2 & 3 & 4 & 5 & 6 & 7 & 1 \\ 3 & 4 & 5 & 6 & 7 & 1 & 2 \\ 4 & 5 & 6 & 7 & 1 & 2 & 3 \\ 5 & 6 & 7 & 1 & 2 & 3 & 4 \\ 6 & 7 & 1 & 2 & 3 & 4 & 5 \\ 7 & 1 & 2 & 3 & 4 & 5 & 6 \\ 1 & 2 & 3 & 4 & 5 & 6 & 7 \end{array}$$

$$L_1^*: \begin{array}{ccccccc} 1 & 2 & 3 & 4 & 5 & 6 & 7 \\ 2 & 3 & 4 & 5 & 6 & 7 & 1 \\ 3 & 4 & 5 & 6 & 7 & 1 & 2 \\ 4 & 5 & 6 & 7 & 1 & 2 & 3 \\ 5 & 6 & 7 & 1 & 2 & 3 & 4 \\ 6 & 7 & 1 & 2 & 3 & 4 & 5 \\ 7 & 1 & 2 & 3 & 4 & 5 & 6 \end{array}$$

For  $k = 2$  we find  $a_{ij}^{(2)} = f_2 f_i + f_j = 2f_i + f_j$ , and this gives

$$L_2: \begin{array}{ccccccc} 3 & 4 & 5 & 6 & 7 & 1 & 2 \\ 5 & 6 & 7 & 1 & 2 & 3 & 4 \\ 7 & 1 & 2 & 3 & 4 & 5 & 6 \\ 2 & 3 & 4 & 5 & 6 & 7 & 1 \\ 4 & 5 & 6 & 7 & 1 & 2 & 3 \\ 6 & 7 & 1 & 2 & 3 & 4 & 5 \\ 1 & 2 & 3 & 4 & 5 & 6 & 7 \end{array}$$

$$L_2^*: \begin{array}{ccccccc} 1 & 2 & 3 & 4 & 5 & 6 & 7 \\ 3 & 4 & 5 & 6 & 7 & 1 & 2 \\ 5 & 6 & 7 & 1 & 2 & 3 & 4 \\ 7 & 1 & 2 & 3 & 4 & 5 & 6 \\ 2 & 3 & 4 & 5 & 6 & 7 & 1 \\ 4 & 5 & 6 & 7 & 1 & 2 & 3 \\ 6 & 7 & 1 & 2 & 3 & 4 & 5 \end{array}$$

For  $k = 3$ ,  $a_{ij}^{(3)} = f_3 f_i + f_j = 3f_i + f_j$  and we have

$$L_3: \begin{array}{cccccc} 4 & 5 & 6 & 7 & 1 & 2 & 3 \\ 7 & 1 & 2 & 3 & 4 & 5 & 6 \\ 3 & 4 & 5 & 6 & 7 & 1 & 2 \\ 6 & 7 & 1 & 2 & 3 & 4 & 5 \\ 2 & 3 & 4 & 5 & 6 & 7 & 1 \\ 5 & 6 & 7 & 1 & 2 & 3 & 4 \\ 1 & 2 & 3 & 4 & 5 & 6 & 7 \end{array}$$

$$L_3^*: \begin{array}{cccccc} 1 & 2 & 3 & 4 & 5 & 6 & 7 \\ 4 & 5 & 6 & 7 & 1 & 2 & 3 \\ 7 & 1 & 2 & 3 & 4 & 5 & 6 \\ 3 & 4 & 5 & 6 & 7 & 1 & 2 \\ 6 & 7 & 1 & 2 & 3 & 4 & 5 \\ 2 & 3 & 4 & 5 & 6 & 7 & 1 \\ 5 & 6 & 7 & 1 & 2 & 3 & 4 \end{array}$$

7. Introduce a third factor such as four types of transmission fluid or four types of tires.
8. (a) Neither of the  $3 \times 3$  Latin squares in Example 17.15(b) is self-orthogonal.
- (b) The  $4 \times 4$  Latin square in Example 17.15(c) is self-orthogonal.
- (c) If not, let  $a_{kk} = a_{mm}$  for some  $1 \leq k < m \leq n$ . Then when  $L$  and  $L^{tr}$  are superimposed we get the ordered pair  $(a_{kk}, a_{kk}) = (a_{mm}, a_{mm})$  and  $L, L^{tr}$  are not orthogonal.

### Section 17.4

1.

Field	Number of Points	Number of Lines	Number of Points on a Line	Number of Lines on a Point
$GF(5)$	25	30	5	6
$GF(3^2)$	81	90	9	10
$GF(7)$	49	56	7	8
$GF(2^4)$	256	272	16	17
$GF(31)$	961	992	31	32

2.

Field	Number of Parallel Classes	Number of Lines per Class
$GF(5)$	6	5
$GF(3^2)$	10	9
$GF(7)$	8	7
$GF(2^4)$	17	16
$GF(31)$	32	31

3. There are nine points and 12 lines. These lines fall into four parallel classes.

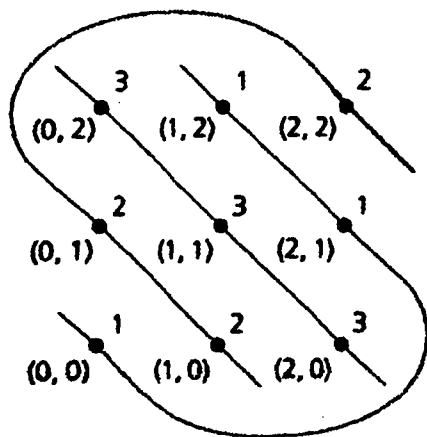

(i) Slope of 0.

$$y = 0; y = 1; y = 2$$

(ii) Infinite slope

$$x = 0; x = 1; x = 2$$

(iii) Slope 1

$$y = x; y = x + 1; y = x + 2$$

(iv) Slope 2 (as shown in the figure).

$$(1) y = 2x$$

$$(2) y = 2x + 1$$

$$(3) y = 2x + 2$$

The Latin square corresponding to the fourth parallel class is

3	1	2
2	3	1
1	2	3

4.

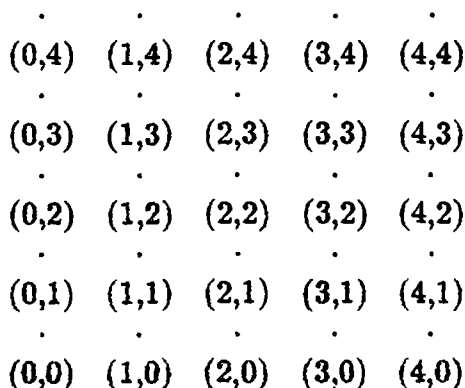

Here there are 25 points and 30 lines. These lines fall into six parallel classes.

(i) Slope 0:

$$y = 0; y = 1; y = 2;$$

$$y = 3; y = 4$$

(ii) Slope 1:

$$y = x; y = x + 1; y = x + 2;$$

$$y = x + 3; y = x + 4.$$

(iii) Slope 2:  $y = 2x; y = 2x + 1; y = 2x + 2; y = 2x + 3; y = 2x + 4$

(iv) Slope 3:  $y = 3x; y = 3x + 1; y = 3x + 2; y = 3x + 3; y = 3x + 4$

(v) Slope 4:  $y = 4x; y = 4x + 1; y = 4x + 2; y = 4x + 3; y = 4x + 4$

(vi) Infinite Slope:  $x = 0; x = 1; x = 2; x = 3; x = 4.$

The Latin square corresponding to the second parallel class is

5	4	3	2	1
4	3	2	1	5
3	2	1	5	4
2	1	5	4	3
1	5	4	3	2

5. (a)  $y = 4x + 1$  (b)  $y = 3x + 10$  or  $2x + 3y + 3 = 0$   
(c)  $y = 10x$  or  $10y = 11x$

6. (a) (A1) fails because the distinct points (2,4) and (5,4) are on both  $y = 2x$  and  $y = 4x + 2$ .

(A2) fails because the point (2,4) is not on the line  $y = 3$ , yet this point is on both  $y = 2x$  and  $y = 4x + 2$ . However, neither  $y = 2x$  nor  $y = 4x + 2$  has a point in common with the line  $y = 3$ .

(A3), however, still holds. The points (0,0), (1,0), (0,1), and (1,1) are such that no three of these points are on the same line.

(b) In this "geometry", each of the 42 lines contains six points, and each of the 36 points is on seven lines.

7. (a) Vertical line:  $x = c$ . The line  $y = mx + b$  intersects this vertical line at the unique point  $(c, mc + b)$ . As  $b$  takes on the values of  $F$ , there are no two column entries (on the line  $x = c$ ) that are the same.

Horizontal line:  $y = c$ . The line  $y = mx + b$  intersects this horizontal line at the unique point  $(m^{-1}(c - b), c)$ . As  $b$  takes on the values of  $F$ , no two row entries (on the line  $y = c$ ) are the same.

(b) Let  $L_i$  be the Latin square for the parallel class of slope  $m_i$ ,  $i = 1, 2$ ,  $m_i \neq 0$ ,  $m_i$  finite. If an ordered pair  $(j, k)$  appears more than once when  $L_1, L_2$  are superimposed, then there are two pairs of lines: (1)  $y = m_1x + b_1$ ,  $y = m_2x + b_2$ ; and (2)  $y = m_1x + b'_1$ ,  $y = m_2x + b'_2$  which both intersect at  $(j, k)$ . But then  $b_1 = k - m_1j = b'_1$  and  $b_2 = k - m_2j = b'_2$ .

### Section 17.5

1.  $v = 9$ ,  $b = 12$ ,  $r = 4$ ,  $k = 3$ ,  $\lambda = 1$ .
2. 1 2 3 1 2 4 1 3 4 2 3 4 ( $\lambda = 2$ )
3.  $\lambda = 2$
- |         |         |         |         |
|---------|---------|---------|---------|
| 1 2 3 4 | 1 3 5 7 | 2 3 6 7 | 3 4 5 6 |
| 1 2 5 6 | 1 4 6 7 | 2 4 5 7 |         |

4.

$v$	$b$	$r$	$k$	$\lambda$
4	4	3	3	2
9	12	4	3	1
10	30	9	3	2
13	13	4	4	1
21	30	10	7	3

These results follow from the information given in the table and the equations (1)  $vr = bk$ ; and (2)  $\lambda(v - 1) = r(k - 1)$ .

5. (a)  $vr = bk \implies 4v = 28(3) \implies v = 21$ ;  $\lambda(v - 1) = r(k - 1) \implies 20\lambda = 4(2) \implies \lambda \notin \mathbf{Z}^+$ , so no such design can exist.

(b)  $vr = bk \implies (17)(8) = 5b \implies b \notin \mathbf{Z}^+$ , so no such design can exist in this case either.

6. With  $v = b$  and  $vr = bk$ , we have  $r = k$ . Then  $\lambda(v - 1) = r(k - 1) = k(k - 1)$ , where one of  $k$  and  $k - 1$  must be even. Hence  $\lambda(v - 1)$  is even. With  $v$  even, it follows that  $v - 1$  is odd, so  $\lambda(v - 1)$  even  $\implies \lambda$  even.

7. (a)  $\lambda(v - 1) = r(k - 1) = 2r \implies \lambda(v - 1)$  is even.  $\lambda v(v - 1) = vr(k - 1) = bk(k - 1) = b(3)(2) \implies 6|\lambda v(v - 1)$ .

(b) Here  $\lambda = 1$ . By part (a)  $6|v(v - 1) \implies 3|v(v - 1) \implies 3|v$  or  $3|(v - 1)$ , since 3 is prime. Also, by part (a)  $\lambda(v - 1) = (v - 1)$  is even, so  $v$  is odd.

(i)  $3|v \implies v = 3t, t$  odd  $\implies v = 3(2s + 1) = 6s + 3$  and  $v \equiv 3 \pmod{6}$ .

(ii)  $3|(v - 1) \implies v - 1 = 3t, t$  even  $\implies v - 1 = 6x \implies v = 6x + 1$  and  $v \equiv 1 \pmod{6}$ .

8. Here  $v = 9, k = 3, b = 12, r = 4$  and  $\lambda(v - 1) = r(k - 1) = 4(2) \implies 8\lambda = 8 \implies \lambda = 1$ , so the design is a Steiner triple system.

9.  $k = 3, \lambda = 1, b = 12 \implies v = 9, r = 4$ .

10. (a) P1) and P2)

(b) P1) and P3)

(c) P1), P2), and P3)

11.  $v = 15, k = 5, \lambda = 2 \implies$  (a)  $b = 21$ ; (b)  $r = 7$

12. Here we have a  $(v, b, r, k, \lambda)$  - design with  $v = 28, k = 7$ , and  $\lambda = 2$ . From Theorem 17.10 it follows that  $6r = (k - 1)r = \lambda(v - 1) = 2(27)$ , so  $r = 9$ , and consequently, there are  $b = vr/k = (28)(9)/7 = 36$  students in Mrs. Mackey's class.

13. There are  $\lambda$  blocks that contain both  $x$  and  $y$ . Since  $r$  is the replication number of the design, it follows that  $r - \lambda$  blocks contain  $x$  but not  $y$ . Likewise there are  $r - \lambda$  blocks containing  $y$  but not  $x$ . Consequently, the number of blocks in the design that contain  $x$  or  $y$  is  $(r - \lambda) + (r - \lambda) + \lambda = 2r - \lambda$ .

14. Here  $v = n$ ,  $b = p$ ,  $k = m$ .
- (a)  $r = bk/v = pm/n$
- (b)  $\lambda(v - 1) = r(k - 1) \implies \lambda(n - 1) = (pm/n)(m - 1) \implies \lambda = [pm(m - 1)]/[n(n - 1)]$ .
15. (a)  $n + 1 = 6 \implies n = 5$ , so there are  $n^2 + n + 1 = 31$  points in this projective plane.
- (b)  $n^2 + n + 1 = 57 \implies n = 7$ , so there are  $n + 1 = 8$  points on each line of this plane.
16. The lines  $y = x$  and  $y = x + z$ , for example, would intersect at the two distinct points  $(0,0,0)$  and  $(1,1,0)$ . This contradicts conditions (P1) and (P2) of Definition 17.14.
17. (a)  $v = b = 31$ ;  $r = k = 6$ ;  $\lambda = 1$
- (b)  $v = b = 57$ ;  $r = k = 8$ ;  $\lambda = 1$
- (c)  $v = b = 73$ ;  $r = k = 9$ ;  $\lambda = 1$
18. (a) There are nine points:
- $(0,0), (1,0), (2,0)$   
 $(0,1), (1,1), (2,1)$   
 $(0,2), (1,2), (2,2)$

and 12 lines:  $x = 0$      $y = 0$      $y = x$      $y = 2x$   
 $x = 1$      $y = 1$      $y = x + 1$      $y = 2x + 1$   
 $x = 2$      $y = 2$      $y = x + 2$      $y = 2x + 2$ .

Here there are four parallel classes, and the parameters for the associated balanced incomplete block design are  $v = 9$ ,  $b = 12$ ,  $r = 4$ ,  $k = 3$ ,  $\lambda = 1$ .

(b) From the nine points in part (a) we get

$(0,0,1), (1,0,1), (2,0,1)$   
 $(0,1,1), (1,1,1), (2,1,1)$   
 $(0,2,1), (1,2,1), (2,2,1)$ .

To these nine we adjoin the four additional points  $(1,0,0)$  and  $(0,1,0)$ ,  $(1,1,0)$ ,  $(2,1,0)$  for the line  $z = 0$ . Consequently, this projective plane has  $9 + 3 + 1 = 3^2 + 3 + 1 = 13$  points and the following 13 lines.

$x = 0:$	$\{(0,0,1),(0,1,1),(0,2,1),(0,1,0)\}$
$y = 0:$	$\{(0,0,1),(1,0,1),(2,0,1),(1,0,0)\}$
$x = z:$	$\{(1,0,1),(1,1,1),(1,2,1),(0,1,0)\}$
$y = z:$	$\{(0,1,1),(1,1,1),(2,1,1),(1,0,0)\}$
$x = 2z:$	$\{(2,0,1),(2,1,1),(2,2,1),(0,1,0)\}$
$y = 2z:$	$\{(0,2,1),(1,2,1),(2,2,1),(1,0,0)\}$
$y = x:$	$\{(0,0,1),(1,1,1),(2,2,1),(1,1,0)\}$
$y = x + z:$	$\{(1,2,1),(2,0,1),(0,1,1),(1,1,0)\}$
$y = x + 2z:$	$\{(1,0,1),(0,2,1),(2,1,1),(1,1,0)\}$
$y = 2x:$	$\{(0,0,1),(1,2,1),(2,1,1),(2,1,0)\}$
$y = 2x + z:$	$\{(0,1,1),(1,0,1),(2,2,1),(2,1,0)\}$
$y = 2x + 2z:$	$\{(0,2,1),(1,1,1),(2,0,1),(2,1,0)\}$
$z = 0 (\ell_\infty):$	$\{(1,0,0),(0,1,0),(1,1,0),(2,1,0)\}$

Since there are four points on  $\ell_\infty$  there are four parallel classes. Finally, the parameters for the associated balanced incomplete block design are  $v = b = 13$ ,  $r = k = 4$ ,  $\lambda = 1$ .

### Supplementary Exercises

- $n = 9$
- (a)  $0 = f(r/s) = a_n(r/s)^n + a_{n-1}(r/s)^{n-1} + \dots + a_1(r/s) + a_0 \implies 0 = a_n r^n + a_{n-1} r^{n-1} s + \dots + a_1 r s^{n-1} + a_0 s^n$ . Since  $s$  divides 0 and  $s$  is a factor of all summands except the first, it follows that  $s$  divides  $a_n r^n$ . With  $\gcd(r, s) = 1$ ,  $s | a_n$ . In similar fashion,  $r | a_0$ .

(b) (i)  $f(x) = 2x^3 + 3x^2 - 2x - 3$ .  
From part (a) the possible rational roots are  $\pm 1, \pm 3, \pm 1/2, \pm 3/2$ .  
 $f(1) = 2(1^3) + 3(1^2) - 2(1) - 3 = 0$ , so 1 is a root of  $f(x)$  and  $x - 1$  is a factor. By long division of polynomials (or synthetic division)  $f(x) = (x - 1)(2x^2 + 5x + 3) = (x - 1)(2x + 3)(x + 1)$ , so the other roots of  $f(x)$  are  $-3/2$  and  $-1$ .

(ii)  $f(x) = x^4 + x^3 - x^2 - 2x - 2$ .  
The possible rational roots are  $\pm 1, \pm 2$ .  $f(1) = -3$ ,  $f(-1) = -1$ ,  $f(2) = 14$ ,  $f(-2) = 6$ , so there are no rational roots. But can we find rational numbers  $a, b, c, d$  so that  $f(x) = (x^2 + ax + b)(x^2 + cx + d)$ ?  
 $(x^2 + ax + b)(x^2 + cx + d) = x^4 + x^3 - x^2 - 2x - 2 \implies a + c = 1, b + ac + d = -1, ad + bc = -2, bd = -2 \implies a = 1, b = 1, c = 0, d = -2$ , so  
 $f(x) = (x^2 + x + 1)(x^2 - 2)$ .

(c) For  $f(x) = x^{100} - x^{50} + x^{20} + x^3 + 1$ , the only possible rational roots are  $\pm 1$ . But  $f(1) = 3 \neq 0$  and  $f(-1) = 1 \neq 0$ , so  $f(x)$  has no rational roots.
- (a) Let  $a, b \in \mathbb{Z}$  with  $(x - a)(x + b) = x^2 + x - n$ . Then  $x^2 + (b - a)x - ab = x^2 + x - n \implies b - a = 1$  and  $ab = n$ . For  $1 \leq a \leq 31$  and  $b = a + 1$ ,  $n = ab \leq 992$ . Hence there are 31 values of  $n$ , namely  $a(a + 1)$  for  $1 \leq a \leq 31$ .

(b) Here  $(x - a)(x + b) = x^2 + 2x - n \implies b - a = 2$  and  $ab = n$ . When  $1 \leq a \leq 30$  and  $b = a + 2$  we find that  $n = ab \leq 960$ , so there are 30 such values of  $n$  in this case.

(c) In this case there are 29 values of  $n$ . Each  $n$  has the form  $a(a + 5)$  for  $1 \leq a \leq 29$ .

(d) If  $(x - a)(x + b) = g(x)$ , then  $b - a = k$  and  $ab = n$ . When  $k = 1000$ ,  $b = a + 1000$  and  $ab = a^2 + 1000a > 1000$ . For  $k = 999$ , with  $a = 1$  and  $b = 1000$  we have  $n = ab = 1000$  and  $x^2 + 999x - 1000 = (x + 1000)(x - 1)$ . In fact, for each  $1 \leq k \leq 999$ , let  $a = 1$ . Then  $b = k + 1$  and  $n = ab = k + 1$ , and it follows that  $x^2 + kx - n = x^2 + kx - (k + 1) = [x + (k + 1)](x - 1)$ . Hence the smallest positive integer  $k$  for which  $g(x)$  cannot be so factored is  $k = 1000$ .

4. If  $F = \mathbf{Z}_2$ , then  $f(1) = 1 + 1 + 1 + 1 = 0$ , so 1 is a root of  $f$  and  $(x - 1) = (x + 1)$  is a factor. If  $F \neq \mathbf{Z}_2$  then  $-1 \in F$  and  $-1 \neq 1$ . Here  $f(-1) = 1 - 1 - 1 + 1 = 0$ , so  $-1$  is a root and  $(x + 1)$  is a factor.

5. For all  $a \in \mathbf{Z}_p$ ,  $a^p = a$  (See part (a) of Exercise 13 at the end of Section 16.3), so  $a$  is a root of  $x^p - x$  and  $x - a$  is a factor of  $x^p - x$ . Since  $(\mathbf{Z}_p, +, \cdot)$  is a field, the polynomial  $x^p - x$  can have at most  $p$  roots. Therefore  $x^p - x = \prod_{a \in \mathbf{Z}_p} (x - a)$ .

6.  $f(x) = x^n + a_{n-1}x^{n-1} + \dots + a_1x + a_0 = (x - r_1)(x - r_2) \cdots (x - r_n)$ .

(a) The coefficient of  $x^{n-1}$  in  $(x - r_1)(x - r_2) \cdots (x - r_n)$  is  $-r_1 - r_2 - \dots - r_n$ , so by comparing coefficients we have  $a_{n-1} = -r_1 - r_2 - \dots - r_n$ , or

$$-a_{n-1} = r_1 + r_2 + \dots + r_n.$$

(b) The constant term in  $(x - r_1)(x - r_2) \cdots (x - r_n)$  is  $(-1)^n r_1 r_2 \cdots r_n$ . Again by comparison of coefficients we find that

$$a_0 = (-1)^n r_1 r_2 \cdots r_n, \quad \text{or}$$

$$(-1)^n a_0 = (-1)^{2n} r_1 r_2 \cdots r_n = r_1 r_2 \cdots r_n.$$

7.  $\{1, 2, 4\}$ ,  $\{2, 3, 5\}$ ,  $\{4, 5, 7\}$

8.  $k = 3$ ,  $\lambda = 1$ ,  $v = 63 \implies r = 31$ ,  $b = 651$

9. (a)  $n^2 + n + 1 = 73 \implies n = 8 \implies n + 1 = 9$ , the number of points on each line.

(b)  $n + 1 = 10 \implies n = 9 \implies n^2 + n + 1 = 91$ , the number of lines in this projective plane.

10. If  $|F| = n$ , then  $n^2 + n + 1 = 91$  and  $n = 9$ . Since there is only one field (up to isomorphism) of order 9, it follows that  $F = GF(3^2)$  which has characteristic 3.

11. (a)  $r$  1's in each row;  $k$  1's in each column.

(b)  $A \cdot J_b$  is a  $v \times b$  matrix whose  $(i, j)$  entry is  $r$ , since there are  $r$  1's in each row of  $A$  and every entry in  $J_b$  is 1. Hence  $A \cdot J_b = rJ_{v \times b}$ . Likewise,  $J_v \cdot A$  is a  $v \times b$  matrix

whose  $(i, j)$  entry is  $k$ , since there are  $k$  1's in each column of  $A$  and every entry in  $J_v$  is 1. Hence  $J_v \cdot A = kJ_{v \times b}$ .

(c) The  $(i, j)$  entry in  $A \cdot A^{tr}$  is obtained from the componentwise multiplication of rows  $i$  and  $j$  of  $A$ . If  $i = j$  this results in the number of 1's in row  $i$ , which is  $r$ . For  $i \neq j$ , the number of 1's is the number of times  $x_i$  and  $x_j$  appear in the same block - this is given by  $\lambda$ . Hence  $A \cdot A^{tr} = (r - \lambda)I_v + \lambda J_v$ .

(d)

$$\begin{array}{c} \left( \begin{array}{cccccc|cccccc} r & \lambda & \lambda & \lambda & \dots & \lambda & r & \lambda-r & \lambda-r & \lambda-r & \dots & \lambda-r \\ \lambda & r & \lambda & \lambda & \dots & \lambda & \lambda & r-\lambda & 0 & 0 & \dots & 0 \\ \lambda & \lambda & r & \lambda & \dots & \lambda & \lambda & 0 & r-\lambda & 0 & \dots & 0 \\ \lambda & \lambda & \lambda & r & \dots & \lambda & \lambda & 0 & 0 & r-\lambda & \dots & 0 \\ \dots & \dots & \dots & \dots & \dots & \dots & \dots & \dots & \dots & \dots & \dots & \dots \\ \lambda & \lambda & \lambda & \lambda & \dots & r \end{array} \right) \xrightarrow{(1)} \left( \begin{array}{cccccc|cccccc} r & \lambda-r & \lambda-r & \lambda-r & \dots & \lambda-r & r & \lambda-r & \lambda-r & \lambda-r & \dots & \lambda-r \\ \lambda & r-\lambda & 0 & 0 & \dots & 0 & \lambda & r-\lambda & 0 & 0 & \dots & 0 \\ \lambda & 0 & r-\lambda & 0 & \dots & 0 & \lambda & 0 & r-\lambda & 0 & \dots & 0 \\ \lambda & 0 & 0 & r-\lambda & \dots & 0 & \lambda & 0 & 0 & r-\lambda & \dots & 0 \\ \dots & \dots & \dots & \dots & \dots & \dots & \dots & \dots & \dots & \dots & \dots & \dots \\ \lambda & 0 & 0 & 0 & \dots & r-\lambda \end{array} \right) \\ \xrightarrow{(2)} \left( \begin{array}{cccccc|cccccc} r+(v-1)\lambda & 0 & 0 & 0 & \dots & 0 & r+(v-1)\lambda & 0 & 0 & 0 & \dots & 0 \\ \lambda & r-\lambda & 0 & 0 & \dots & 0 & \lambda & r-\lambda & 0 & 0 & \dots & 0 \\ \lambda & 0 & r-\lambda & 0 & \dots & 0 & \lambda & 0 & r-\lambda & 0 & \dots & 0 \\ \lambda & 0 & 0 & r-\lambda & \dots & 0 & \lambda & 0 & 0 & r-\lambda & \dots & 0 \\ \dots & \dots & \dots & \dots & \dots & \dots & \dots & \dots & \dots & \dots & \dots & \dots \\ \lambda & 0 & 0 & 0 & \dots & r-\lambda \end{array} \right) \end{array}$$

$$[r + (v - 1)\lambda](r - \lambda)^{v-1} = (r - \lambda)^{v-1}[r + r(k - 1)] = rk(r - \lambda)^{v-1}$$

(1) Multiply column 1 by  $-1$  and add it to the other  $v - 1$  columns.

(2) Add rows 2 through  $v$  to row 1.

12. (a) Here  $V = \{1, 2, \dots, 9\}$  and the 12 blocks are

$$\begin{array}{cccccc} 3 & 4 & 5 & 7 & 8 & 9 & 1 & 5 & 6 & 7 & 8 & 9 & 1 & 2 & 4 & 5 & 6 & 9 \\ 2 & 4 & 6 & 7 & 8 & 9 & 1 & 3 & 4 & 6 & 7 & 9 & 1 & 2 & 3 & 6 & 7 & 8 \\ 2 & 3 & 5 & 6 & 8 & 9 & 1 & 3 & 4 & 5 & 6 & 8 & 1 & 2 & 3 & 5 & 7 & 8 \\ 2 & 3 & 4 & 5 & 6 & 7 & 1 & 2 & 4 & 5 & 7 & 8 & 1 & 2 & 3 & 4 & 8 & 9 \end{array}$$

Furthermore  $r' = 8$ ,  $k' = 6$ ,  $\lambda' = 5$ .

(b) In general we find that

$$r' = b - r, \quad k' = v - k, \quad \text{and} \quad \lambda' = b - [2r - \lambda] = b - 2r + \lambda.$$

**THE  
APPENDICES**

APPENDIX 1  
EXPONENTIAL AND LOGARITHMIC FUNCTIONS

1. (a)  $\sqrt{xy^3} = x^{1/2}y^{3/2}$  (b)  $\sqrt[4]{81x^{-5}y^3} = 3x^{-5/4}y^{3/4} = \frac{3y^{3/4}}{x^{5/4}}$   
(c)  $5\sqrt[3]{8x^9y^{-5}} = 5(8^{1/3}x^{9/3}y^{-5/3}) = 5(2x^3y^{-5/3}) = \frac{10x^3}{y^{5/3}}$
2. (a)  $125^{-4/3} = 1/(125)^{4/3} = 1/[(125)^{1/3}]^4 = 1/5^4 = 1/625$   
(b)  $0.027^{2/3} = [(0.027)^{1/3}]^2 = (0.3)^2 = 0.09$   
(c)  $(4/3)(1/8)^{-2/3} = (4/3)[1/(1/8)^{2/3}] = (4/3)[1/[(1/8)^{1/3}]^2] = (4/3)[1/(1/2)^2] = (4/3)[1/(1/4)] = (4/3)(4) = 16/3$
3. (a)  $(5^{3/4})(5^{13/4}) = 5^{(3/4)+(13/4)} = 5^{16/4} = 5^4 = 625$   
(b)  $(7^{3/5})/(7^{18/5}) = 7^{(3/5)-(18/5)} = 7^{(3-18)/5} = 7^{-15/5} = 7^{-3} = 1/7^3 = 1/343$   
(c)  $(5^{1/2})(20^{1/2}) = (5^{1/2})(4 \cdot 5)^{1/2} = (5^{1/2})(4^{1/2})(5^{1/2}) = 2(5^{1/2})^2 = 2(5) = 10$
4. (a)  $5^{3x^2} = 5^{5x+2} \Rightarrow 3x^2 = 5x + 2 \Rightarrow 3x^2 - 5x - 2 = 0 \Rightarrow (3x + 1)(x - 2) = 0 \Rightarrow x = -1/3$   
or  $x = 2$ .  
(b)  $4^{x-1} = (1/2)^{4x-1} \Rightarrow 2^{2(x-1)} = 2^{-(4x-1)} \Rightarrow 2(x-1) = -(4x-1) \Rightarrow 2x-2 = -4x+1 \Rightarrow 6x = 3 \Rightarrow x = 1/2$
5. (a)  $\log_2 128 = 7$  (b)  $\log_{125} 5 = 1/3$   
(c)  $\log_{10} 1/10,000 = -4$  (d)  $\log_2 b = a$
6. (a) 2 (b) -3 (c) 11  
(d) -6 (e) 3/2 (f) 1/3  
(g) 0 (h) 2/3
7. (a)  $x^5 = 243 \Rightarrow x = 3$  (b)  $x = 3^{-3} = 1/27$   
(c)  $10^x = 1000 \Rightarrow x = 3$  (d)  $x^{5/2} = 32 \Rightarrow x = 32^{2/5} \Rightarrow x = 4$

8. Proof: Let  $x = \log_b r$  and  $y = \log_b s$ . Then, because  $x = \log_b r \iff b^x = r$  and  $y = \log_b s \iff b^y = s$ , we have

$$r/s = b^x/b^y = b^{x-y},$$

from part (2) of Theorem A1.1.

Since

$$r/s = b^{x-y} \iff \log_b(r/s) = x - y,$$

it follows that

$$\log_b(r/s) = x - y = \log_b r - \log_b s.$$

9. (a) Proof (by Mathematical Induction):

For  $n = 1$  the statement is  $\log_b r^1 = 1 \cdot \log_b r$ , so the result is true for this first case.

Assuming the result for  $n = k$  ( $\geq 1$ ) we have:  $\log_b r^k = k \log_b r$ . Now for the case where  $n = k + 1$  we find that  $\log_b r^{k+1} = \log_b(r \cdot r^k) = \log_b r + \log_b r^k$  (by part (a) of Theorem A1.2)  $= \log_b r + k \log_b r$  (by the induction hypothesis)  $= (1 + k) \log_b r = (k + 1) \log_b r$ .

Therefore the result follows for all  $n \in \mathbf{Z}^+$  by the Principle of Mathematical Induction.

(b) For all  $n \in \mathbf{Z}^+$ ,  $\log_b r^{-n} = \log_b(1/r^n) = \log_b 1 - \log_b r^n$  (by part (b) of Theorem A1.2)  $= 0 - n \log_b r$  (by part (a) above)  $= (-n) \log_b r$ .

10. (a)  $\log_2 10 = \log_2(2 \cdot 5) = \log_2 2 + \log_2 5 = 1 + 2.3219 = 3.3219$

(b)  $\log_2 100 = \log_2 10^2 = 2 \log_2 10 = 2(3.3219) = 6.6438$

(c)  $\log_2(7/5) = \log_2 7 - \log_2 5 = 2.8074 - 2.3219 = 0.4855$

(d)  $\log_2 175 = \log_2(7 \cdot 25) = \log_2 7 + 2 \log_2 5 = 2.8074 + 2(2.3219) = 7.4512$

11. (a) Let  $x = \log_2 3$ . Then  $2^x = 3$  and  $x(\ln 2) = \ln 2^x = \ln 3$ , so  $\log_2 3 = x = \ln 3 / \ln 2 = 1.0986 / 0.6931 \doteq 1.5851$ .

(b)  $\log_5 2 = \ln 2 / \ln 5 = 0.6931 / 1.6094 \doteq 0.4307$

(c)  $\log_3 5 = \ln 5 / \ln 3 = 1.6094 / 1.0986 \doteq 1.4650$

12. (a)  $\log_{10} x = \log_{10}(2 \cdot 5) \implies x = 10$

(b)  $\log_4 3x = \log_4 7/5 \implies 3x = 7/5 \implies x = 7/15$ .

13. (a)  $1 = \log_{10} x + \log_{10} 6 = \log_{10} 6x \implies 6x = 10^1 = 10 \implies x = 10/6 = 5/3$ .

(b)  $\ln(x/(x-1)) = \ln 3 \implies x/(x-1) = 3 \implies x = 3(x-1) \implies x = 3x - 3 \implies -2x = -3 \implies x = 3/2$ .

$$\begin{aligned}
 \text{(c)} \quad 2 &= \log_3(x^2 + 4x + 4) - \log_3(2x - 5) = \log_3\left[\frac{(x^2 + 4x + 4)}{(2x - 5)}\right] \implies 3^2 = 9 = \\
 &= \frac{(x^2 + 4x + 4)}{(2x - 5)} \implies 9(2x - 5) = x^2 + 4x + 4 \implies 18x - 45 = x^2 + 4x + 4 \implies \\
 &x^2 - 14x + 49 = 0 \implies (x - 7)^2 = 0 \implies x = 7.
 \end{aligned}$$

$$14. \quad \log_2 x = (1/3)[\log_2 3 - \log_2 5] + (2/3)\log_2 6 + \log_2 17 = \log_2(3/5)^{1/3} + \log_2 6^{2/3} + \log_2 17 = \log_2[17(108/5)^{1/3}] \implies x = 17(108/5)^{1/3}$$

15. Proof: Let  $x = a^{\log_b c}$  and  $y = c^{\log_a b}$ . Then

$$x = a^{\log_b c} \implies \log_b x = \log_b [a^{\log_b c}] = (\log_b c)(\log_b a), \text{ and}$$

$$y = c^{\log_a b} \implies \log_b y = \log_b [c^{\log_a b}] = (\log_b a)(\log_b c).$$

Consequently, we find that  $\log_b x = \log_b y$  from which it follows that  $x = y$ .

APPENDIX 2  
PROPERTIES OF MATRICES

1.

$$(a) \quad A + B = \begin{bmatrix} 3 & 2 & 5 \\ 0 & 2 & 7 \end{bmatrix}$$

$$(b) \quad (A + B) + C = \begin{bmatrix} 3 & 3 & 7 \\ 5 & 6 & 4 \end{bmatrix}$$

$$(c) \quad B + C = \begin{bmatrix} 1 & 2 & 3 \\ 6 & 6 & 1 \end{bmatrix}$$

$$(d) \quad A + (B + C) = \begin{bmatrix} 3 & 3 & 7 \\ 5 & 6 & 4 \end{bmatrix}$$

$$(e) \quad 2A = \begin{bmatrix} 4 & 2 & 8 \\ -2 & 0 & 6 \end{bmatrix}$$

$$(f) \quad 2A + 3B = \begin{bmatrix} 7 & 5 & 11 \\ 1 & 6 & 18 \end{bmatrix}$$

$$(g) \quad 2C + 3C = \begin{bmatrix} 0 & 5 & 10 \\ 25 & 20 & -15 \end{bmatrix}$$

$$(h) \quad 5C = \begin{bmatrix} 0 & 5 & 10 \\ 25 & 20 & -15 \end{bmatrix}$$

$$(i) \quad 2B - 4C = \begin{bmatrix} 2 & -2 & -6 \\ -18 & -12 & 20 \end{bmatrix}$$

$$(j) \quad A + 2B - 3C = \begin{bmatrix} 4 & 0 & 0 \\ -14 & -8 & 20 \end{bmatrix}$$

$$(k) \quad 2(3B) = \begin{bmatrix} 6 & 6 & 6 \\ 6 & 12 & 24 \end{bmatrix}$$

$$(l) \quad (2 \cdot 3)B = \begin{bmatrix} 6 & 6 & 6 \\ 6 & 12 & 24 \end{bmatrix}$$

2.  $3a + 4 = 2, \quad a = -2/3; \quad 3b - 8 = 0, \quad b = 8/3;$   
 $3c - 12 = 10, \quad c = 22/3; \quad 3d - 8 = 6, \quad d = 14/3$

3.

$$(a) \quad [12], \text{ or } 12$$

$$(b) \quad \begin{bmatrix} 9 & 21 \\ 12 & 27 \end{bmatrix}$$

$$(c) \quad \begin{bmatrix} -10 & -10 \\ 18 & 24 \end{bmatrix}$$

$$(d) \quad \begin{bmatrix} -5 & -7 & 8 \\ 29 & 21 & 2 \\ -23 & -35 & 6 \end{bmatrix}$$

$$(e) \quad \begin{bmatrix} a & b & c \\ d & e & f \\ 3g & 3h & 3i \end{bmatrix}$$

$$(f) \quad \begin{bmatrix} a & b & c \\ 3g & 3h & 3i \\ d & e & f \end{bmatrix}$$

4. (a)  $AB + AC = \begin{bmatrix} -1 & 4 \\ 1 & 2 \\ 0 & 3 \end{bmatrix} \begin{bmatrix} 1 & 2 & -4 \\ 1 & 3 & 5 \end{bmatrix} + \begin{bmatrix} -1 & 4 \\ 1 & 2 \\ 0 & 3 \end{bmatrix} \begin{bmatrix} 0 & 3 & -2 \\ -2 & -7 & 6 \end{bmatrix}$

$$\begin{bmatrix} 3 & 10 & 24 \\ 3 & 8 & 6 \\ 3 & 9 & 15 \end{bmatrix} + \begin{bmatrix} -8 & -31 & 26 \\ -4 & -11 & 10 \\ -6 & -21 & 18 \end{bmatrix} = \begin{bmatrix} -5 & -21 & 50 \\ -1 & -3 & 16 \\ -3 & -12 & 33 \end{bmatrix}$$

$$A(B+C) = \begin{bmatrix} -1 & 4 \\ 1 & 2 \\ 0 & 3 \end{bmatrix} \left( \begin{bmatrix} 1 & 2 & -4 \\ 1 & 3 & 5 \end{bmatrix} + \begin{bmatrix} 0 & 3 & -2 \\ -2 & -7 & 6 \end{bmatrix} \right)$$

$$= \begin{bmatrix} -1 & 4 \\ 1 & 2 \\ 0 & 3 \end{bmatrix} \begin{bmatrix} 1 & 5 & -6 \\ -1 & -4 & 11 \end{bmatrix} = \begin{bmatrix} -5 & -21 & 50 \\ -1 & -3 & 16 \\ -3 & -12 & 33 \end{bmatrix}$$

$$(b) BA + CA = \begin{bmatrix} 1 & 2 & -4 \\ 1 & 3 & 5 \end{bmatrix} \begin{bmatrix} -1 & 4 \\ 1 & 2 \\ 0 & 3 \end{bmatrix} + \begin{bmatrix} 0 & 3 & -2 \\ -2 & -7 & 6 \end{bmatrix} \begin{bmatrix} -1 & 4 \\ 1 & 2 \\ 0 & 3 \end{bmatrix}$$

$$= \begin{bmatrix} 1 & -4 \\ 2 & 25 \end{bmatrix} + \begin{bmatrix} 3 & 0 \\ -5 & -4 \end{bmatrix} = \begin{bmatrix} 4 & -4 \\ -3 & 21 \end{bmatrix}$$

$$(B+C)A = \left( \begin{bmatrix} 1 & 2 & -4 \\ 1 & 3 & 5 \end{bmatrix} + \begin{bmatrix} 0 & 3 & -2 \\ -2 & -7 & 6 \end{bmatrix} \right) \begin{bmatrix} -1 & 4 \\ 1 & 2 \\ 0 & 3 \end{bmatrix}$$

$$= \begin{bmatrix} 1 & 5 & -6 \\ -1 & -4 & 11 \end{bmatrix} \begin{bmatrix} -1 & 4 \\ 1 & 2 \\ 0 & 3 \end{bmatrix} = \begin{bmatrix} 4 & -4 \\ -3 & 21 \end{bmatrix}$$

5. (a)  $(-1/5) \begin{bmatrix} 1 & -2 \\ -3 & 1 \end{bmatrix}$       (b)  $\begin{bmatrix} 0 & 1 \\ 1 & 0 \end{bmatrix}$       (c) The inverse does not exist.

(d)  $\begin{bmatrix} 1 & 3 \\ 2 & 7 \end{bmatrix}$

6. (a)  $A = \begin{bmatrix} 2 & 2 \\ 2 & 3 \end{bmatrix}^{-1} \begin{bmatrix} 1 & 0 \\ 1 & -5 \end{bmatrix} = (1/2) \begin{bmatrix} 3 & -2 \\ -2 & 2 \end{bmatrix} \begin{bmatrix} 1 & 0 \\ 1 & -5 \end{bmatrix} = (1/2) \begin{bmatrix} 1 & 10 \\ 0 & -10 \end{bmatrix}$

(b)  $A = \begin{bmatrix} 2 & 3 \\ 3 & 5 \end{bmatrix}^{-1} \left( \begin{bmatrix} 3 & 2 \\ -1 & 1 \end{bmatrix} + \begin{bmatrix} 1 & 3 \\ 2 & 1 \end{bmatrix} \right) = \begin{bmatrix} 5 & -3 \\ -3 & 2 \end{bmatrix} \begin{bmatrix} 4 & 5 \\ 1 & 2 \end{bmatrix} = \begin{bmatrix} 17 & 19 \\ -10 & -11 \end{bmatrix}$

7. (a)  $A^{-1} = (1/2) \begin{bmatrix} 2 & -1 \\ 0 & 1 \end{bmatrix}$       (b)  $B^{-1} = (1/5) \begin{bmatrix} 1 & -2 \\ 3 & -1 \end{bmatrix}$       (c)  $AB = \begin{bmatrix} -4 & 3 \\ -6 & 2 \end{bmatrix}$

(d)  $(AB)^{-1} = (1/10) \begin{bmatrix} 2 & -3 \\ 6 & -4 \end{bmatrix}$       (e)  $B^{-1}A^{-1} = (1/10) \begin{bmatrix} 2 & -3 \\ 6 & -4 \end{bmatrix}$

8. (a) -2

(b) -10

(c) -10

(d) -50

9. (a)  $\begin{bmatrix} 3 & -2 \\ 4 & -3 \end{bmatrix} \begin{bmatrix} x \\ y \end{bmatrix} = \begin{bmatrix} 5 \\ 6 \end{bmatrix}$

$$\begin{bmatrix} x \\ y \end{bmatrix} = \begin{bmatrix} 3 & -2 \\ 4 & -3 \end{bmatrix}^{-1} \begin{bmatrix} 5 \\ 6 \end{bmatrix} = (-1) \begin{bmatrix} -3 & 2 \\ -4 & 3 \end{bmatrix} \begin{bmatrix} 5 \\ 6 \end{bmatrix} = \begin{bmatrix} 3 \\ 2 \end{bmatrix}$$

(b)  $\begin{bmatrix} 5 & 3 \\ 3 & -2 \end{bmatrix} \begin{bmatrix} x \\ y \end{bmatrix} = \begin{bmatrix} 35 \\ 2 \end{bmatrix}$

$$\begin{bmatrix} x \\ y \end{bmatrix} = \begin{bmatrix} 5 & 3 \\ 3 & -2 \end{bmatrix}^{-1} \begin{bmatrix} 35 \\ 2 \end{bmatrix} = (-1/19) \begin{bmatrix} -2 & -3 \\ -3 & 5 \end{bmatrix} \begin{bmatrix} 35 \\ 2 \end{bmatrix} = \begin{bmatrix} 4 \\ 5 \end{bmatrix}$$

10. (a) 21

(b) 21

(c) 21

(d) 63

11.  $\det(2A) = 2^2(31) = 124$ ,  $\det(5A) = 5^2(31) = 775$

12. (a)  $\begin{vmatrix} 1 & 0 & -2 \\ 3 & 1 & -1 \\ 4 & 1 & 2 \end{vmatrix} = 3(-1)^{2+1} \begin{vmatrix} 0 & -2 \\ 1 & 2 \end{vmatrix} + 1(-1)^{2+2} \begin{vmatrix} 1 & -2 \\ 4 & 2 \end{vmatrix}$

$$+ (-1)(-1)^{2+3} \begin{vmatrix} 1 & 0 \\ 4 & 1 \end{vmatrix} = -3(2) + (10) + 1 = 5$$

$$\begin{vmatrix} 1 & 0 & -2 \\ 3 & 1 & -1 \\ 4 & 1 & 2 \end{vmatrix} = (-2)(-1)^{1+3} \begin{vmatrix} 3 & 1 \\ 4 & 1 \end{vmatrix} + (-1)(-1)^{2+3} \begin{vmatrix} 1 & 0 \\ 4 & 1 \end{vmatrix}$$

$$+ 2(-1)^{3+3} \begin{vmatrix} 1 & 0 \\ 3 & 1 \end{vmatrix} = -2(-1) + 1 + 2(1) = 5$$

(b)  $\begin{vmatrix} 1 & 1 & 2 \\ 2 & 3 & -4 \\ 0 & 5 & 7 \end{vmatrix} = 1(-1)^{1+1} \begin{vmatrix} 3 & -4 \\ 5 & 7 \end{vmatrix} + 1(-1)^{1+2} \begin{vmatrix} 2 & -4 \\ 0 & 7 \end{vmatrix}$

$$+ 2(-1)^{1+3} \begin{vmatrix} 2 & 3 \\ 0 & 5 \end{vmatrix} = (21 + 20) - (14) + 2(10) = 47$$

$$\begin{vmatrix} 1 & 1 & 2 \\ 2 & 3 & -4 \\ 0 & 5 & 7 \end{vmatrix} = (1)(-1)^{1+2} \begin{vmatrix} 2 & -4 \\ 0 & 7 \end{vmatrix} + 3(-1)^{2+2} \begin{vmatrix} 1 & 2 \\ 0 & 7 \end{vmatrix}$$

$$+ 5(-1)^{3+2} \begin{vmatrix} 1 & 2 \\ 2 & -4 \end{vmatrix} = (-1)(14) + 3(7) - 5(-8) = 47$$

$$13. \quad (a) \quad \begin{vmatrix} 1 & 0 & 2 \\ 6 & -2 & 1 \\ 4 & 3 & 2 \end{vmatrix} = (1)(-1)^{1+1} \begin{vmatrix} -2 & 1 \\ 3 & 2 \end{vmatrix} + 2(-1)^{1+3} \begin{vmatrix} 6 & -2 \\ 4 & 3 \end{vmatrix} =$$

$$(-4 - 3) + 2(18 + 8) = -7 + 52 = 45$$

$$(b) \quad \begin{vmatrix} 4 & 7 & 0 \\ 4 & 2 & 0 \\ 3 & 6 & 2 \end{vmatrix} = (2)(-1)^{3+3} \begin{vmatrix} 4 & 7 \\ 4 & 2 \end{vmatrix} = (2)(8 - 28) = -40$$

$$(c) \quad \begin{vmatrix} 1 & 2 & -4 \\ 0 & 1 & 0 \\ 3 & 3 & 2 \end{vmatrix} = (1)(-1)^{1+1} \begin{vmatrix} 1 & -4 \\ 3 & 2 \end{vmatrix} = 2 + 12 = 14$$

14. (a) (i) 0 (ii) 0 (iii) 0 (iv) 0

(b) Let  $A$  be a  $3 \times 3$  matrix. If two rows of  $A$  are identical, or if two columns of  $A$  are identical, then  $\det(A) = 0$ . In fact, for each  $n \in \mathbf{Z}^+$  where  $n > 1$ , if  $A$  is an  $n \times n$  matrix with two identical rows or two identical columns, then  $\det(A) = 0$ .

$$15. \quad (a) \quad (i) \quad \begin{vmatrix} 1 & 2 & 1 \\ 0 & -1 & -1 \\ 2 & 3 & 0 \end{vmatrix} = 2(-1)^{3+1} \begin{vmatrix} 2 & 1 \\ -1 & -1 \end{vmatrix} + 3(-1)^{3+2} \begin{vmatrix} 1 & 1 \\ 0 & -1 \end{vmatrix}$$

$$= 2(-2 - (-1)) - 3(-1) = 2(-1) + 3 = 1.$$

(ii) 5 (iii) 25

(b) (i) 51 (ii) 306 (iii) 510

16. There are  $n^2$  entries in the matrix product  $AB$ . For each entry we perform  $n$  multiplications and  $n - 1$  additions. Therefore, in total, we perform  $n^3$  multiplications and  $n^2(n - 1) = n^3 - n^2$  additions.

APPENDIX 3  
COUNTABLE AND UNCOUNTABLE SETS

1. (a) True (b) False (c) True  
 (d) True (e) True (f) True  
 (g) False: Let  $A = \mathbf{Z}^+ \cup (0, 1]$  and  $B = (0, 1]$ . Then  $A, B$  are both uncountable, but  $A - B = \{2, 3, 4, \dots\}$  is countable.

2. (a) The function  $f : \mathbf{Z}^+ \rightarrow A$  defined by  $f(n) = n^2$  is a one-to-one correspondence.  
 (b) Let  $g : \mathbf{Z}^+ \rightarrow \{2, 6, 10, 14, \dots\}$  be defined by  $g(n) = (n-1)4+2$ . Then  $g$  is a one-to-one correspondence.

3. If  $B$  were countable, then by Theorem A3.3 it would follow that  $A$  is countable. This leads us to a contradiction since we are given that  $A$  is uncountable.

4. The set  $I$  of irrational numbers is uncountable. If not, then  $\mathbf{R} = \mathbf{Q} \cup I$  would be countable — by virtue of Theorems A3.8 and A3.9 (or, A3.7).

5. Since  $S, T$  are countably infinite, we know from Theorem A3.2 that we can write  $S = \{s_1, s_2, s_3, \dots\}$  and  $T = \{t_1, t_2, t_3, \dots\}$  — two (infinite) sequences of distinct terms. Define the function

$$f : S \times T \rightarrow \mathbf{Z}^+$$

by  $f(s_i, t_j) = 2^i 3^j$ , for all  $i, j \in \mathbf{Z}^+$ . If  $i, j, k, \ell \in \mathbf{Z}^+$  with  $f(s_i, t_j) = f(s_k, t_\ell)$ , then  $f(s_i, t_j) = f(s_k, t_\ell) \Rightarrow 2^i 3^j = 2^k 3^\ell \Rightarrow i = k, j = \ell$  (By the Fundamental Theorem of Arithmetic)  $\Rightarrow s_i = s_k$  and  $t_j = t_\ell \Rightarrow (s_i, t_j) = (s_k, t_\ell)$ . Therefore  $f$  is a one-to-one function and  $S \times T \sim f(S \times T) \subset \mathbf{Z}^+$ . So from Theorem A3.3 we know that  $S \times T$  is countable.

6. Let  $p, q, r$  be three distinct primes. Define the function  $f : \mathbf{Z}^+ \times \mathbf{Z}^+ \times \mathbf{Z}^+ \rightarrow \mathbf{Z}^+$  by  $f(a, b, c) = p^a q^b r^c$ . If  $a_1, b_1, c_1, a_2, b_2, c_2 \in \mathbf{Z}^+$  with  $f(a_1, b_1, c_1) = f(a_2, b_2, c_2)$ , then  $f(a_1, b_1, c_1) = f(a_2, b_2, c_2) \Rightarrow p^{a_1} q^{b_1} r^{c_1} = p^{a_2} q^{b_2} r^{c_2} \Rightarrow a_1 = a_2, b_1 = b_2, c_1 = c_2$  (By the Fundamental Theorem of Arithmetic)  $\Rightarrow (a_1, b_1, c_1) = (a_2, b_2, c_2)$ . Consequently,  $f$  is a one-to-one function and  $\mathbf{Z}^+ \times \mathbf{Z}^+ \times \mathbf{Z}^+ \sim f(\mathbf{Z}^+ \times \mathbf{Z}^+ \times \mathbf{Z}^+) \subset \mathbf{Z}^+$ . By Theorem A3.3 it then follows that  $\mathbf{Z}^+ \times \mathbf{Z}^+ \times \mathbf{Z}^+$  is countable.

7. The function  $f : (\mathbf{Z} - \{0\}) \times \mathbf{Z} \times \mathbf{Z} \rightarrow \mathbf{Q}$  given by  $f(a, b, c) = 2^a 3^b 5^c$  is one-to-one. (Verify this!) So by Theorems A3.3 and A3.8 it follows that  $(\mathbf{Z} - \{0\}) \times \mathbf{Z} \times \mathbf{Z}$  is countable. Now

for all  $(a, b, c) \in (\mathbf{Z} - \{0\}) \times \mathbf{Z} \times \mathbf{Z}$  there are at most two (distinct) real solutions for the quadratic equation  $ax^2 + bx + c = 0$ . From Theorem A3.9 it then follows that the set of all real solutions of the quadratic equations  $ax^2 + bx + c = 0$ , where  $a, b, c \in \mathbf{Z}$  and  $a \neq 0$ , is countable.

8. (a)  $f(x) = 3x, \quad 0 < x < 1$   
(b)  $g(x) = 5x + 2, \quad 0 < x < 1$   
(c)  $h(x) = (b - a)x + a, \quad 0 < x < 1$